

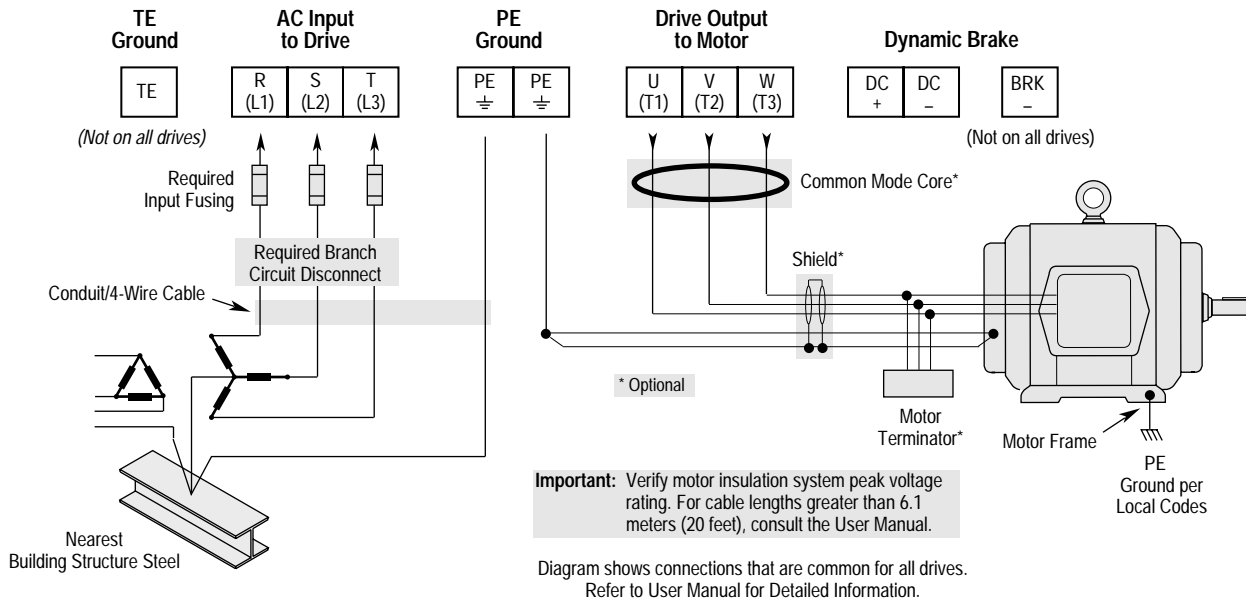

This Quick Start Guide summarizes the basic steps needed to install, start-up, and program the 1336 IMPACT Adjustable Frequency AC Drive. The information provided Does Not replace the User Manual and is intended for qualified drive service personnel only. Refer to the 1336 IMPACT User Manual (publication 1336 IMPACT-5.0) for details on other application considerations and related precautions.

Power Wiring – TB1



Jumper Locations

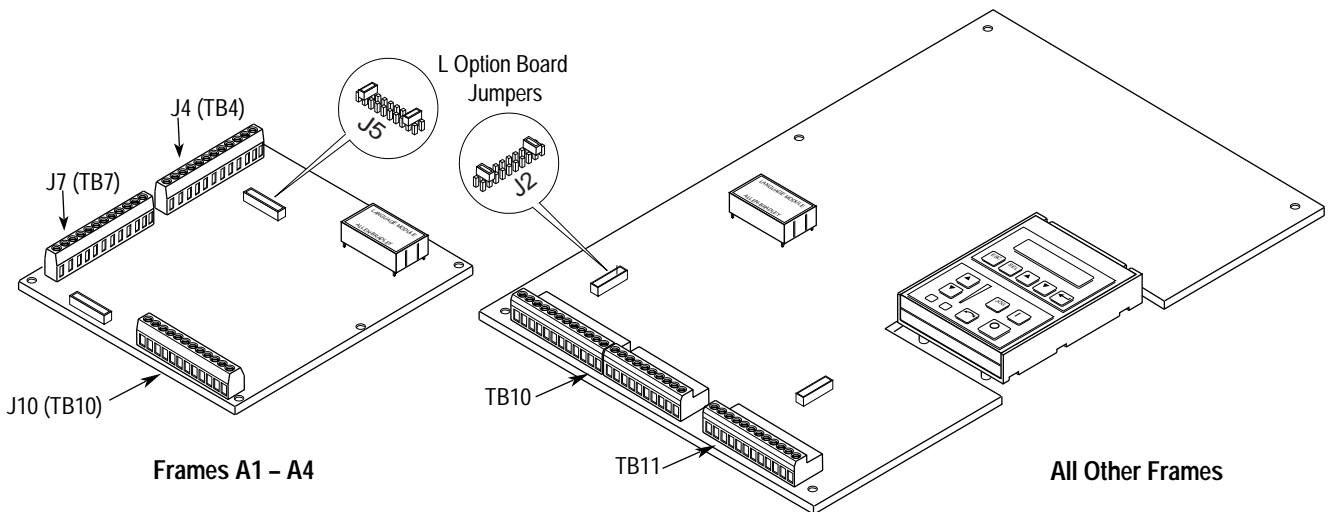

Wiring I/O – A-Frames

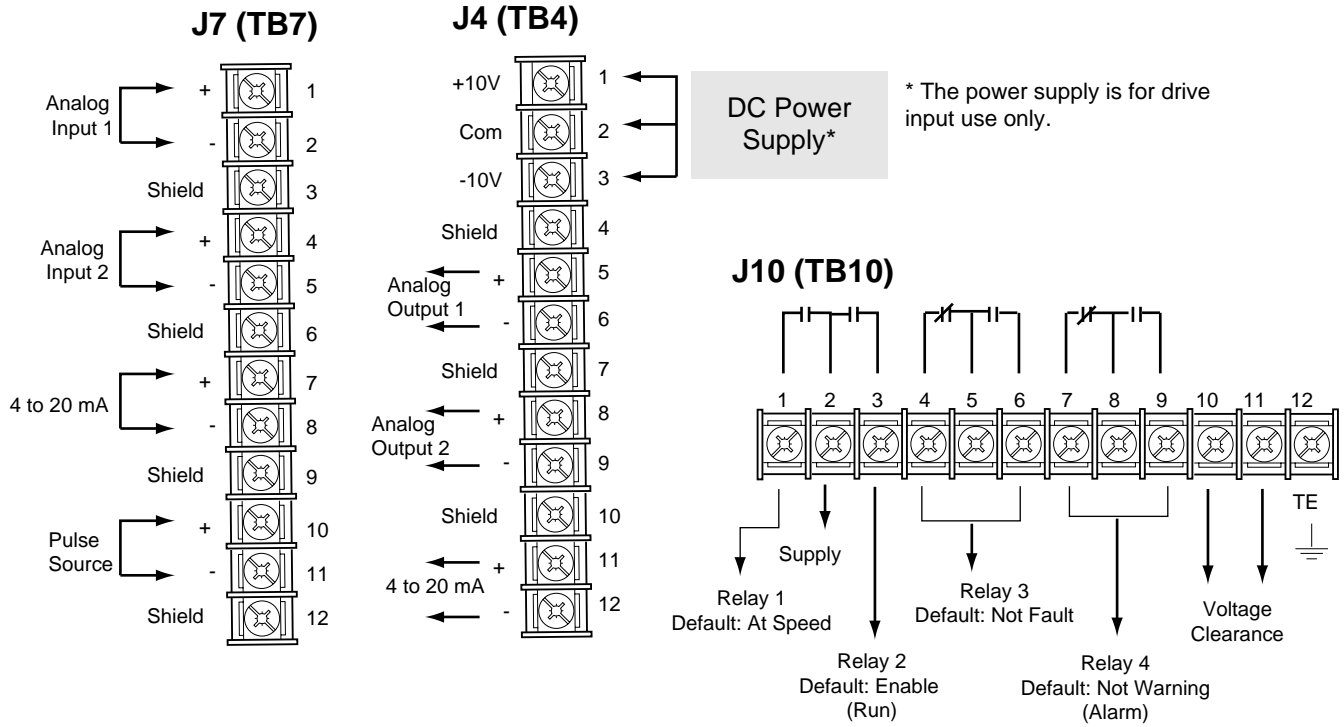

Wiring I/O - All Other Frames

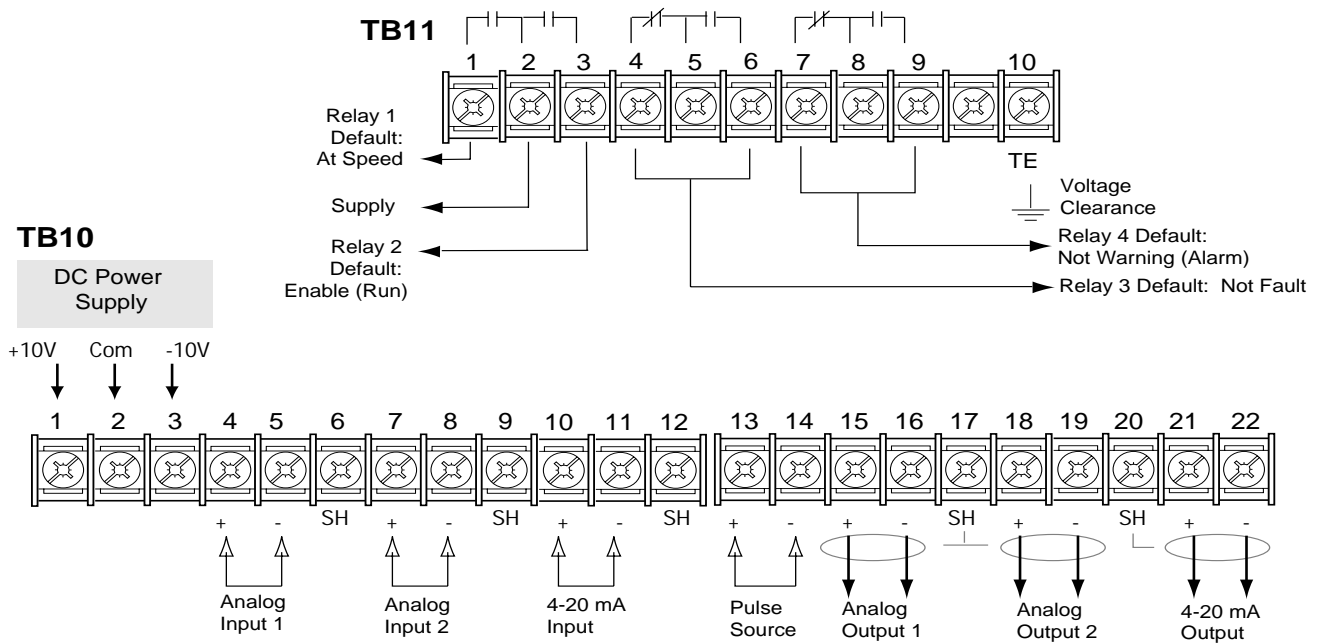

L Option Board

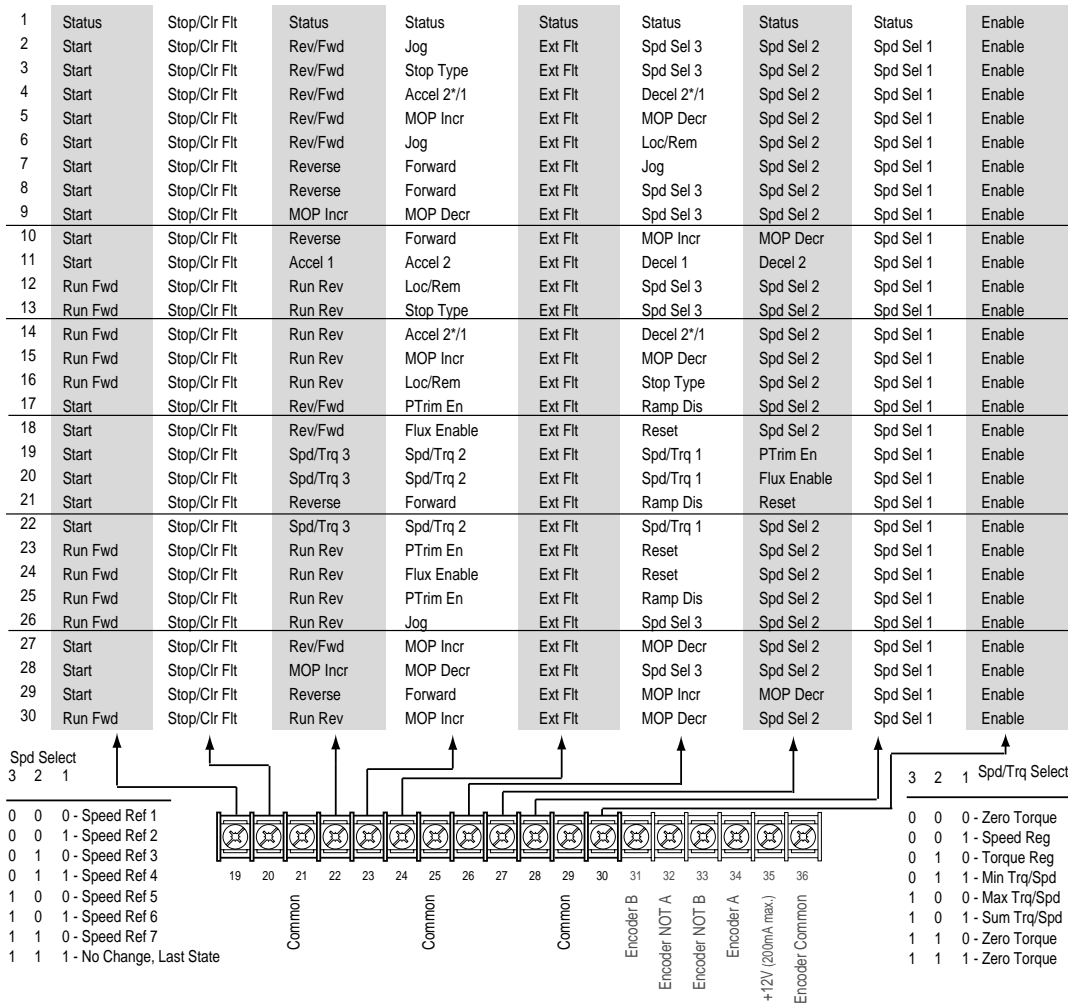

Start-Up

This start-up procedure covers only the most commonly adjusted values using the 1336 IMPACT “Startup” mode. Refer to the User Manual for detailed information.

The following procedure is written for users who have a Human Interface Module (HIM) installed. For users without a HIM, respective external commands and signals must be supplied. It is also assumed that all parameters are at factory default settings.



ATTENTION: Power must be applied to the drive to perform the following. Some of the voltages present are at incoming line potential. To avoid a shock hazard or damage to equipment, only qualified drive service personnel should perform the following procedure. Thoroughly read and understand the procedure before beginning. If an event does not occur while performing this procedure, Do Not Proceed. Remove power by opening the branch circuit disconnect device and correct the malfunction before continuing.



ATTENTION: To avoid a hazard of electric shock when wiring or servicing the drive, verify that the voltage on the bus capacitors has discharged. Measure the DC bus voltage at the + and - terminals of TB1. The voltage must be zero.

1. Verify that AC line power and control power match the drive rating.
2. If an L option is installed, verify that the Stop and Enable interlock inputs are present. If this option is not installed, verify that jumpers are installed at pins 3 and 4 and 17 and 18 on J5 on A Frame drives or J2 on B Frame and up drives. Refer to Jumper Locations.
3. If standard I/O is being used, verify that jumpers are wired correctly.
4. If Analog Option is installed, verify that parameters are properly configured (refer to the User Manual).



ATTENTION: In all of the following steps, rotation of the motor may occur. To guard against injury, incorrect rotation, and possible equipment damage, read each step carefully and perform with caution.

5. Apply AC power and control voltages to the drive. The LCD display should light and display a drive status of “Stopped” and an output frequency of “+0.00 Hz.” If the drive detects a fault, a statement relating to the fault will be shown on the display. Record the information, remove power, and correct the fault source before proceeding.
6. From the Status Display, press the Enter key (or any key). “Choose Mode” will be displayed. Press the Increment (or Decrement) key until “Startup is displayed. Press Enter.

Important: All questions can be answered Yes or No. Pressing Enter will select the default (“Y” or “N”). Pressing the Increment (or Decrement) key will change the selection. Press Enter to select. Choosing “Y” allows you to proceed through the step, and choosing “No” will advance you to the next step. The figure below shows the steps involved.

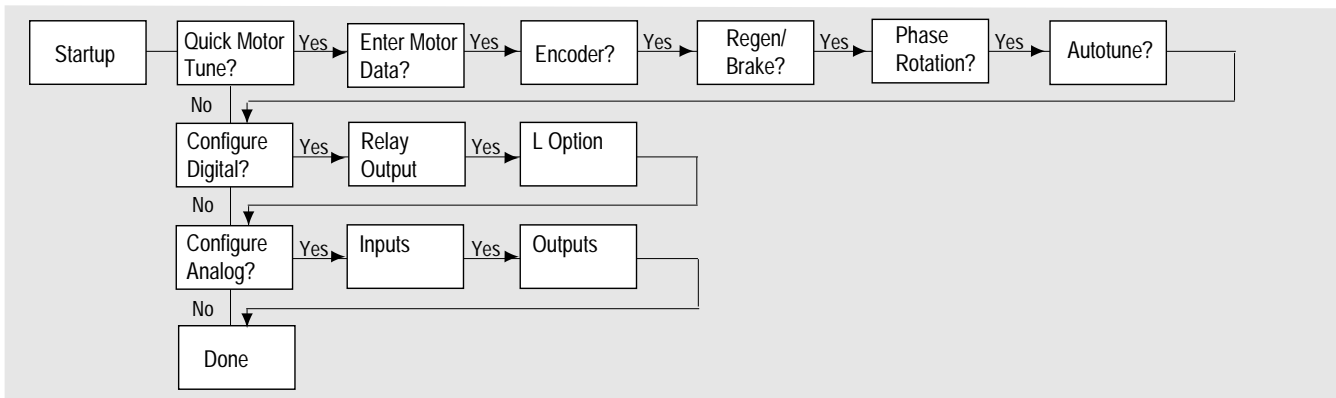

Important: Please note the following:

- The “Startup” mode can be exited at any time by pressing ESCape until the Status Display is shown. If you wish to re-enter the “Startup” mode, simply select “Reset Sequence” to start from the beginning. Selecting “Continue” allows you to resume from the point where you left off.
 - Completing the last action in any step will automatically take you to the next step.
 - Pressing SElect will activate line 2 of the display. This must be done for all values.
 - Press the Increment (or Decrement) key to adjust a value (skip if value is correct). Press Enter to store the value or retain existing value. Pressing Enter again will cause you to move to the next step (parameter)
7. Cycle power to activate changes. This completes the “Assisted Startup” procedure. Depending on your application, further parameter programming and/or “Advanced Startup” may be required. Refer to the User Manual for details.

Drive Dimensions

To determine the size of your drive, refer to the following illustration and table.

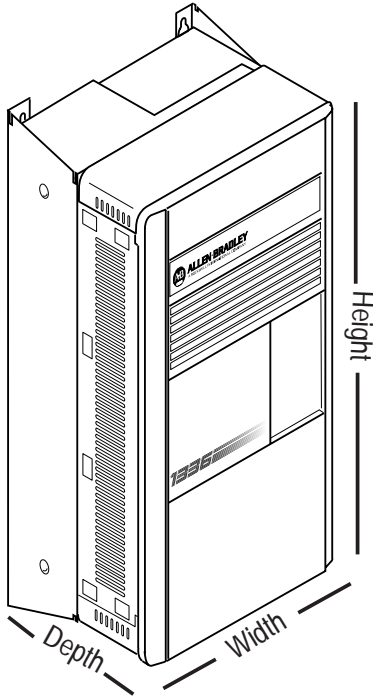

Frame	Width x Height x Depth Millimeters (inches)
A1	215.9 (8.50) x 290.0 (11.42) x 160.0 (6.30)
A2	215.9 (8.50) x 290.0 (11.42) x 180.5 (7.10)
A3	215.9 (8.50) x 290.0 (11.42) x 207.0 (8.15)
A4	260.0 (10.24) x 350.0 (13.78) x 212.0 (8.35)
B	276.4 (10.88) x 476.3 (18.75) x 225.0 (8.86)
C	301.8 (11.88) x 701.0 (27.60) x 225.0 (8.86)
D	381.5 (15.02) x 1240.0 (48.82) x 270.8 (10.66)
E-Enclosed	511.0 (20.12) x 1498.6 (59.00) x 477.5 (18.80)
E-Open	511.0 (20.12) x 1498.6 (59.00) x 372.6 (14.67)
F	762.0 (30.00) x 2286.0 (90.00) x 635.0 (25.00)
G	762.0 (30.00) x 2387.6 (94.0) x 635.0 (25.00)
H	1270.0 (50) x 2324.1 (91.50) ^① x 635.0 (25)

^① Fan height (635.0 (25.00)) not included.

HIM Operation

Parameter programming or viewing is accomplished through the Program or Display modes shown below.

1. From the Status Display, press to display "Choose Mode."

2. Press or to display "Program" (or "Display").

3. Press .

4. Press or until the desired file is displayed.

5. Press .

6. Press or until the desired group is displayed.

7. Press .

8. Press or to scroll to the desired parameter.

HIM Structure

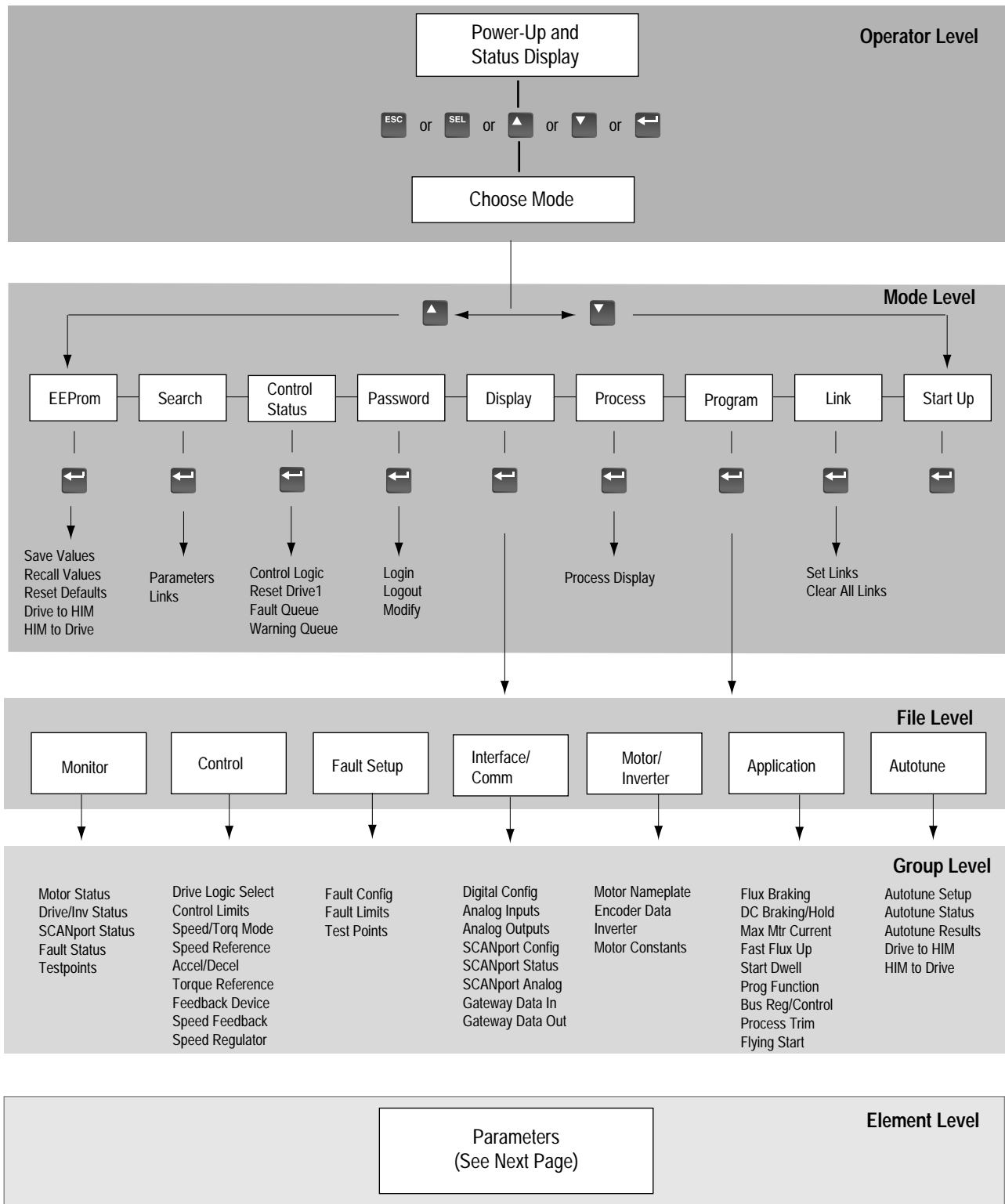

efesotomasyon.com

Parameters - Files, Groups, and Elements

Name	No.	Min./Max. Value	Name	No.	Min./Max. Value
Monitor			Neg Mtr Cur Lim	73	Calc/0.0%
Motor Status			Pos Torque Lim	74	0.0%/Calc
Motor Speed	81	-8 x BMS/+8 x BMS	Neg Power Lim	75	Calc/0.0%
Motor Frequency	89	-250.000/+250.000 Hz	Regen Power Lim	76	-800.0%/0.0%
Motor Current	83	0.0/6553.5 amps	Current Rate Lim	77	Calc/200.0%
Motor Voltage	85	0/+3000 volts	Max Mtr Current	195	0/1
Motor Voltage %	234	0/800%	Min Speed Limit	215	0.0/BMS rpm
Motor Torque %	86	-800.0/+800.0%	Speed/Torq Mode		
Motor Flux %	88	12.5/100.0%	Spd/Trq Mode Sel	68	0/5
Motor Power%	90	-800.0/+800.0%	Speed Reference		
Enc Pos Fdbk Low	227	0/65535	Speed Ref 1	29	-8x/+8xBMS rpm
Enc Pos Fdbk Hi	228	0/65535	Speed Scale 1	30	-3.9999/+3.9999
Int Torque Ref	229	-800/+800%	Speed Ref 2	31	-8x/+8xBMS rpm
Drive/Inv Status			Speed Ref 3	32	-8x/+8xBMS rpm
DC Bus Voltage	84	0/1000V	Speed Ref 4	33	-8x/+8xBMS rpm
Logic Input Sts	14	Bit selection	Speed Ref 5	34	-8x/+8xBMS rpm
Drive/Inv Status	15	Bit selection	Speed Ref 6	35	-8x/+8xBMS rpm
Drive/Inv Sts 2	196	Bit selection	Speed Ref 7	36	-8x/+8xBMS rpm
Run Inhibit Sts	16	Bit selection	Speed Scale 7	37	-3.9999/+3.9999
Command Spd Sts	82	-8 x BMS/+8 x BMS	Jog Speed 1	38	-8x/+8xBMS rpm
Torque Limit Sts	87	Bit selection	Jog Speed 2	39	-8x/+8xBMS rpm
Spd Reg Output	225	-300.0/+300.0%	Accel/Decel		
Spd Error	226	-8 x BMS/+8 x BMS	Accel Time 1	42	0.0/6553.5 sec
SCANport Status			Accel Time 2	43	0.0/6553.5 sec
Dir/Ref Owner	128	Bit selection	Decel Time 1	44	0.0/6553.5 sec
Start/Stop Owner	129	Bit selection	Decel Time 2	45	0.0/6553.5 sec
Jog1/Jog2 Owner	130	Bit selection	S-Curve Percent	47	0.0/100.0%
Ramp/CIFit Owner	131	Bit selection	Torque Reference		
Flux/Trim Owner	132	Bit selection	Torque Ref 1	69	-800.0/+800.0%
Fault Status			Slave Torque %	70	-200.00/+200.00%
PwrUp Flt Status	219	Bit selection	Feedback Device		
Ncfg Flt Status	220	Bit selection	Fdbk Device Type	64	1/3
Fault Status 1	221	Bit selection	Encoder PPR	8	Calc/20000 ppr
Fault Status 2	222	Bit selection	Speed Feedback		
Warning Status 1	223	Bit selection	Scaled Spd Fdbk	63	-32767/+32767
Warning Status 2	224	Bit selection	Fdbk Filter Sel	65	0/4
Testpoints			Fdbk Filter Gain	66	-5.00/+5.00
Test Data 1	92	-32768/+32767	Fdbk Filter BW	67	0.2/900.0 rad/sec
Test Select 1	93	0/65535	Notch Filtr Freq	185	5.0/135.0 Hz
Test Data 2	94	-32768/+32767	Notch Filtr Q	186	2/500
Test Select 2	95	0/65535	Speed Regulator		
Control			Total Inertia	157	0.01 sec/655.00 sec
Drive Logic Select			Spd Desired BW	161	0.00 rad/sec/Calc
Logic Options	17	Bit selections	Ki Speed Loop	158	0.0/4095.9
Stop Dwell Time	18	0.0/10.0 sec	Kp Speed Loop	159	0.0/200.0
Zero Speed Tol	19	0.0 rpm/8xBMS rpm	Kf Speed Loop	160	0.500/1.000
Start Dwell Spd	193	-0.1/+0.1 x BMS	Error Filtr BW	162	Calc/1500.0 rad/sec
Start Dwell Time	194	0.0/10.0 sec	Droop Percent	146	0.0/25.5%
Control Limits			Fault Setup		
Rev Speed Limit	40	-6xBMS rpm/0.0 rpm	Fault Config		
Fwd Speed Limit	41	0.0 rpm/+6xBMS rpm	Fault Select 1	20	Bit selection
Pos Mtr Cur Lim	72	0.0%/Calc	Warning Select 1	21	Bit selection

Name	No.	Min./Max. Value	Name	No.	Min./Max. Value
Fault Config cont.			SCANport Config		
Fault Select 2	22	Bit Selection	SP2 Wire Enable	181	Bit Selection
Warning Select 2	23	Bit Selection	SP Enable Mask	124	Bit Selection
Fault Limits			Dir/Ref Mask	125	Bit Selection
Absolute Overspd	24	0.0 rpm/BMS rpm	Start/Jog Mask	126	Bit Selection
Motor Stall Time	25	0.1/3276.7 sec	Clr Flt/Res Mask	127	Bit Selection
Motor Overload %	26	110.0/400.0%	SCANport Status		
Line Undervolts	27	10.0/90.0%	Dir/Ref Owner	128	Bit selection
Testpoints			Start/Stop Owner	129	Bit selection
Test Data 1	92	-32768/+32768	Jog1/Jog2	130	Bit selection
Test Select 1	93	0/65535	Ramp/CIFlt Owner	131	Bit selection
Test Data 2	94	-32768/+32767	Flux/Trim Owner	132	Bit selection
Test Select 2	95	0/65535	SCANport Analog		
Interface/Comm			SP An In1 Select	133	1/16
Digital Config			SP An In1 Value	134	-32767/+32767
Relay Config	114	0/38	SP An In1 Scale	135	-1.000/+1.000
Relay Config 1	115	-800.0/+800.0%	Sp An In2 Select	136	1/16
Relay Config 2	187	0/36	Sp An In2 Value	137	-32767/+32767
Relay Setpoint 2	188	800.0/+800.0	Sp An In2 Scale	138	-1.000/+1.000
Relay Config 3	189	0/36	Sp An Output	139	-32767/+32767
Relay Setpoint 3	190	-800.0/+800.0	Gateway Data In		
Relay Config 4	191	0/36	Data In A1	140	-32767/+32767
Relay Setpoint 4	192	-800/+800.0%	Data In A2	141	-32767/+32767
L Option Mode	116	1/25	Data In B1	142	-32767/+32767
L Option In Sts	117	Bit Selection	Data In B2	143	-32767/+32767
Mop Increment	118	0.0/BMS	Data In C1	144	-32767/+32767
Mop Value	119	0.0/BSMNA	Data In C2	145	-32767/+3276
Pulse In PPR	120	500/2000	Data In D1	146	-32767/+32767
Pulse In Scale	121	0.01/10.00	Data In D2	147	-32767/+32767
Pulse In Offset	122	-BMS/+BMS	Gateway Data Out		
Pulse In Value	123	0.0/+8xBMS	Data Out A1	148	-32767/+32767
Analog Inputs			Data Out A2	149	-32767/+32767
An In 1 Value	96	-32767/+32767	Data Out B1	150	-32767/+32767
An In 1 Offset	97	-19.980/+19.980 volts	Data Out B2	151	-32767/+32767
An In 1 Scale	98	-16.000/+16.000	Data Out C1	152	-32767/+32767
An In 1 Filter BW	182	0.0/200.0 rad/sec	Data Out C2	153	-32767/+32767
An In 2 Value	99	-32767/+32767	Data Out D1	154	-32767/+32767
An In 2 Offset	100	-19.980/+19.980 volts	Data Out D2	155	-32767/+32767
An In 2 Scale	101	-16.000/+16.000			
An In2 Filter BW	183	0.0/200.0 rad/sec			
mA Input Value	102	-32767/+32767			
mA In Offset	103	-32.000/+32.000 mA			
mA In Scale	104	-16.00			
mA In Filter BW	184	0.0/200.0 rad/sec			
Analog Outputs					
An Out 1 Value +0	105	-32767/+32767			
An Out 1 Offset	106	-20.000/+20.000			
An Out 1 Scale	107	-1.000/+1.000			
An Out 2 Value	108	-32767/+32767			
An Out 2 Offset	109	-19.980/+19.980 volts			
An Out 2 Scale	110	-1.000/+1.000			
mA Out Value	111	-32767/+32767			
mA Out Offset	112	-32.000/+32.000 mA			
mA Out Scale	113	-1.000/+1.000			

Name	No.	Min./Max. Value	Name	No.	Min./Max. Value
Motor Inverter			Function Sel	212	0/27
Motor Nameplate			Function Output1	213	Varies
Nameplate HP	2	0.2 hp/2000.0 hp	Function Output2	214	0/65535
Nameplate RPM	3	1 rpm/1500 rpm	Function In9	232	-32767/+32767
Nameplate Amps	4	0.1 amps/Calc	Function In 10	233	-32767/+32767
Nameplate Volts	5	75 volts/575 volts	Bus Reg Control		
Nameplate Hz	6	1.0/250.0 Hz	Bus/Brake Option	13	Bit selection
Motor Poles	7	2/40 poles	Process Trim		
Service Factor	9	1.00/2.00	PTrim Output	48	-800.0/+800.0%
Encoder Data			PTrim Reference	49	-800.0/+800.0%
Encoder PPR	8	Calc/2000 ppr	PTrim Feedback	50	-800.0/+800.0%
Inverter			PTrim Select	51	Bit selection
PWM Frequency	10	1000 Hz/From drive	PTrim Filter BW	52	0.0/240.0 rad/sec
Inverter Amps	11	0.1 amps/From drive	PTrim Preload	53	-800.0/+800.0%
Inverter Volts	12	75/575 volts	PTrim Ki	54	0.000/16.000
Motor Constants			PTrim Kp	55	0.000/16.000
Stator Resistance	166	0.00/100.00%	PTrim Lo Limit	58	-800.0/+800.0%
Leak Inductance	167	0.00/100.00%	PTrim Hi Limit	59	-800.0/+800.0%
Flux Current	168	0.00/75.00%	PTrim Out Gain	60	-8.000/+8.000
Slip Gain	169	0.0/400.0%	Max Rev Spd Trim	61	-6 x /0.0 BMS rpm
Motor Poles	7	2/40 poles	Max Fwd Spd Trim	62	0.0 rpm/+6xBMS rpm
Application			Flying Start		
Flux Braking			FStart Select	216	0/2
Bus/Brake Option	13	Bit selection	FStart Speed	217	P40/P41
DC Braking/Hold			Autotune		
Bus/Brake Option	13	Bit selection	Autotune Setup		
DC Brake Current	79	0.0%/Calc	Autotune/Dgn Sel	173	Bit selection
DC Brake Time	80	0.0/6553.5 sec	Trans Dgn Config	172	Bit selection
400% Mtr Current			Autotune Torque	64	250%/100.0%
Max Mtr Current	195	0/1	Autotune Speed	165	0.3 x BMS/BMS
Fast Flux Up			Autotune Status		
Bus/Brake Option	13	Bit selection	Autotune Status	156	Bit selection
Fast Flux Level	78	100.0%/Calc	Inverter Dgn 1	174	Bit selection
Start Dwell			Inverter Dgn 2	175	Bit selection
Start Dwell Spd	193	-0.1 x / +0.1 x BMS	Autotune Errors	176	Bit selection
Start Dwell Time	194	0.0/10.0 sec	Autotune Results		
Prog Function			Stator Resistance	166	0.00/100.00%
Function In1	198	Varies	Leak Inductance	167	0.00/100.00%
Func 1 Mask/Val	199	Varies	Flux Current	168	0.00/75.00%
Func 1 Eval Sel	200	0/17	Slip Gain	169	0.0/400%
Function In2	201	Varies	Total Inertia	157	0.0/655.00 sec
Func 2 Mask/Val	202	Varies	Spd Desired BW	161	0.00/Calc rad/sec
Func 2 Eval Sel	203	0/17			
Function In3	204	Varies			
Func 3 Mask/Val	205	Varies			
Func 3 Eval Sel	206	0/17			
Function In4	207	Varies			
Function In5	208	Varies			
Function In6	209	Varies			
Function In7	210	Varies			
Function In8	211	Bit selection			

This Page Intentionally Blank



Allen-Bradley, a Rockwell Automation Business, has been helping its customers improve productivity and quality for more than 90 years. We design, manufacture and support a broad range of automation products worldwide. They include logic processors, power and motion control devices, operator interfaces, sensors and a variety of software. Rockwell is one of the world's leading technology companies.

Worldwide representation.



Argentina • Australia • Austria • Bahrain • Belgium • Brazil • Bulgaria • Canada • Chile • China, PRC • Colombia • Costa Rica • Croatia • Cyprus • Czech Republic • Denmark • Ecuador • Egypt • El Salvador • Finland • France • Germany • Greece • Guatemala • Honduras • Hong Kong • Hungary • Iceland • India • Indonesia • Ireland • Israel • Italy • Jamaica • Japan • Jordan • Korea • Kuwait • Lebanon • Malaysia • Mexico • Netherlands • New Zealand • Norway • Pakistan • Peru • Philippines • Poland • Portugal • Puerto Rico • Qatar • Romania • Russia-CIS • Saudi Arabia • Singapore • Slovakia • Slovenia • South Africa, Republic • Spain • Sweden • Switzerland • Taiwan • Thailand • Turkey • United Arab Emirates • United Kingdom • United States • Uruguay • Venezuela • Yugoslavia

Allen-Bradley Headquarters, 1201 South Second Street, Milwaukee, WI 53204 USA, Tel: (1) 414 382-2000 Fax: (1) 414 382-4444