

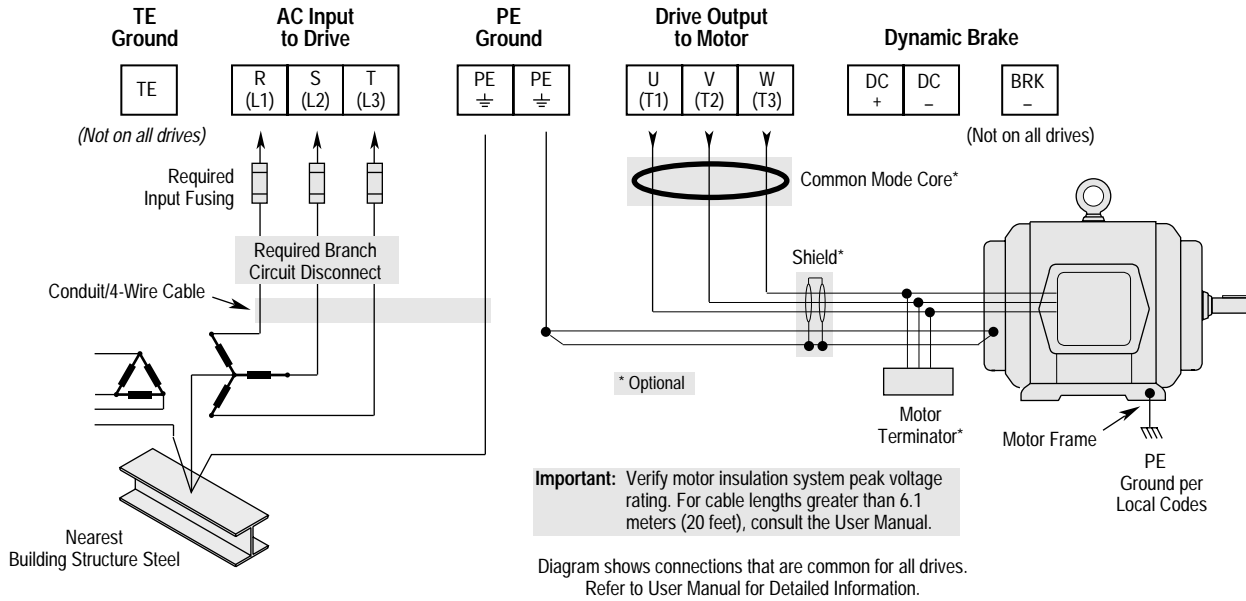

This Quick Start Guide summarizes the basic steps needed to install, start-up, and program the 1336 IMPACT Adjustable Frequency AC Drive. The information provided Does Not replace the User Manual and is intended for qualified drive service personnel only. Refer to the 1336 IMPACT User Manual (publication 1336 IMPACT-5.0) for details on other application considerations and related precautions.

## Power Wiring – TB1



## Jumper Locations

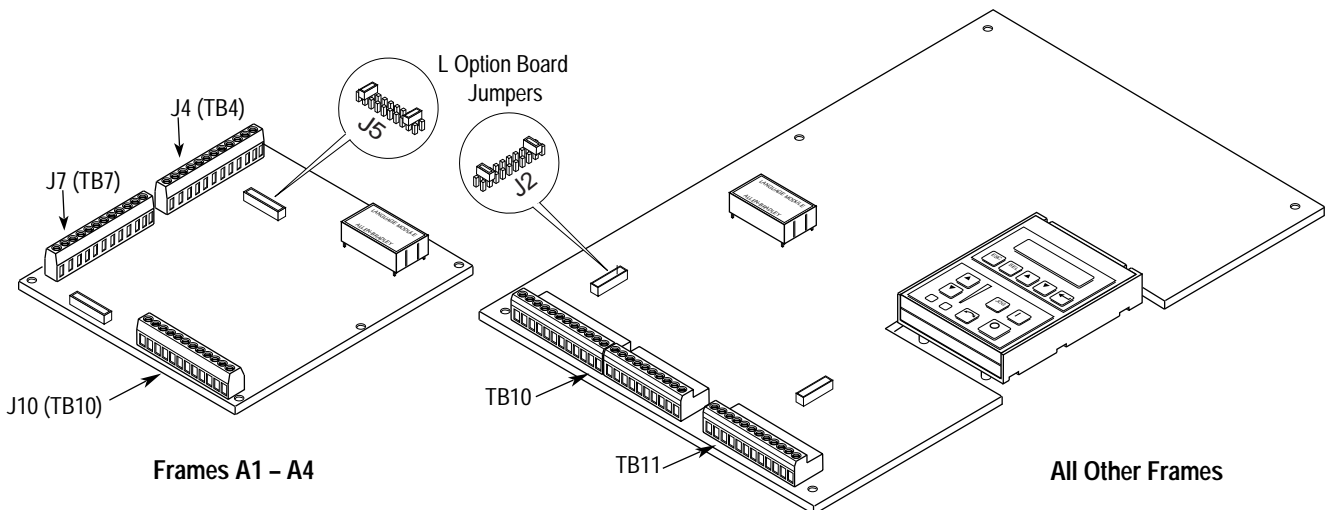

## Wiring I/O – A-Frames

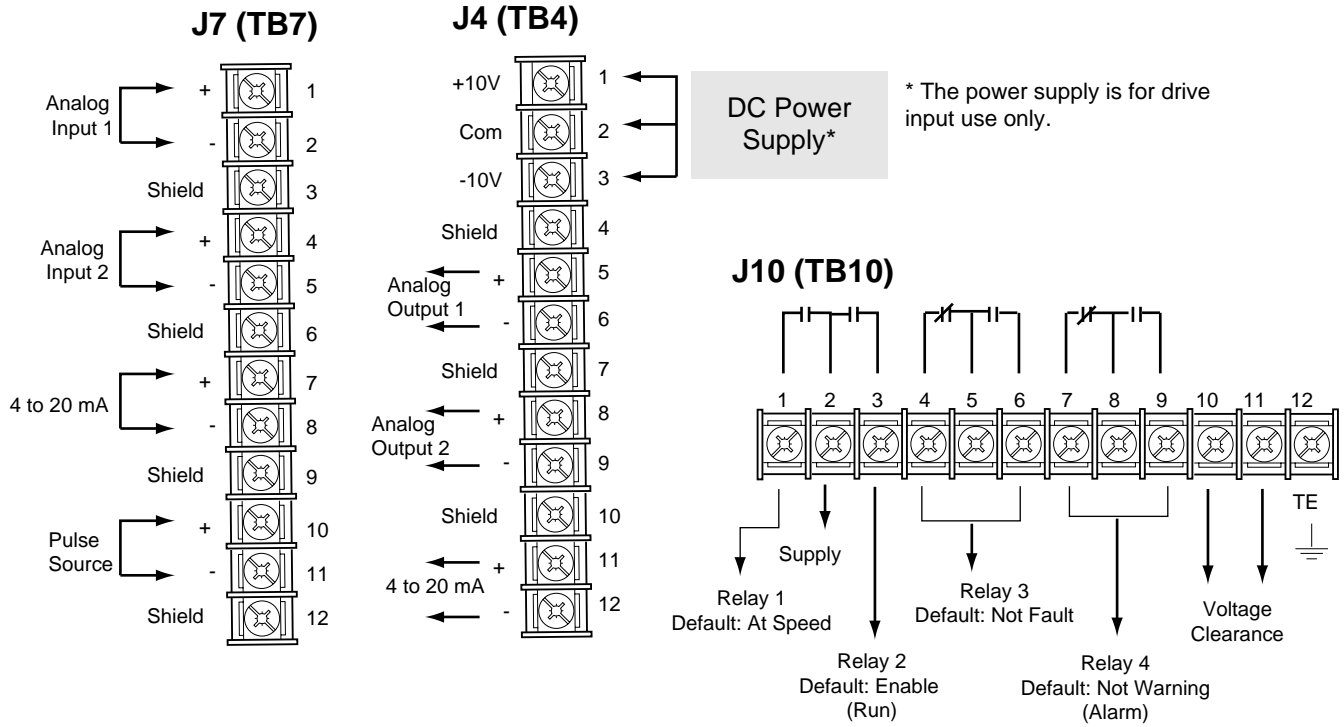

## Wiring I/O - All Other Frames

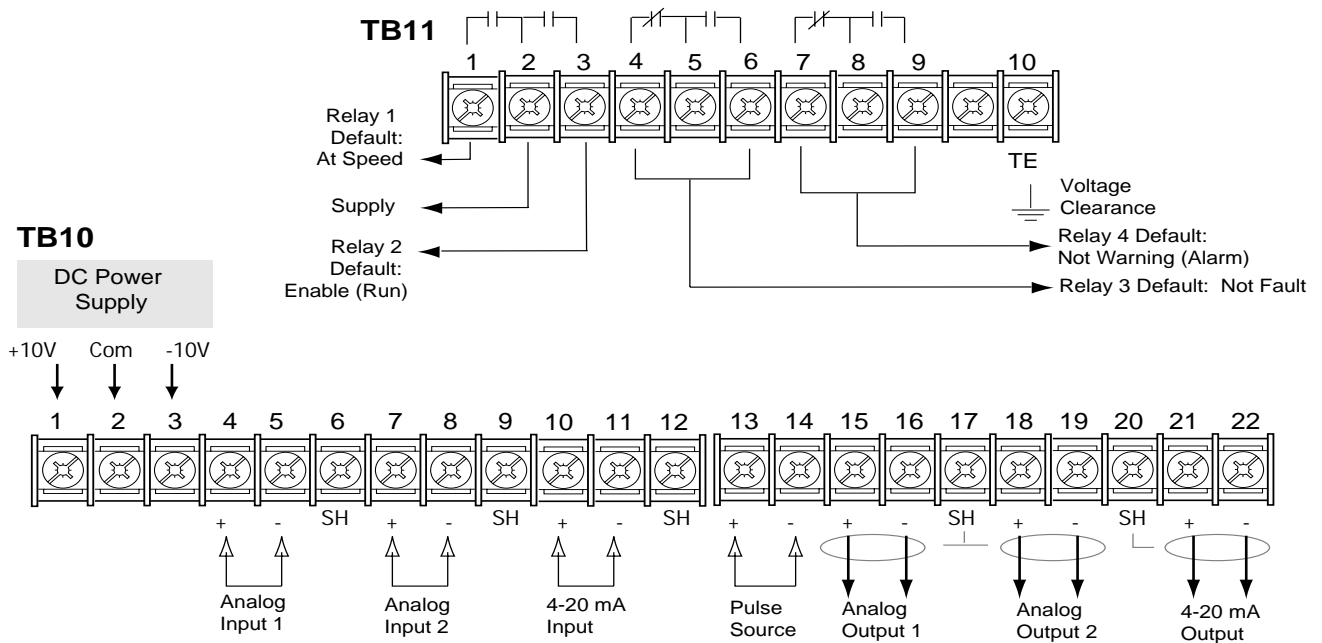

## L Option Board

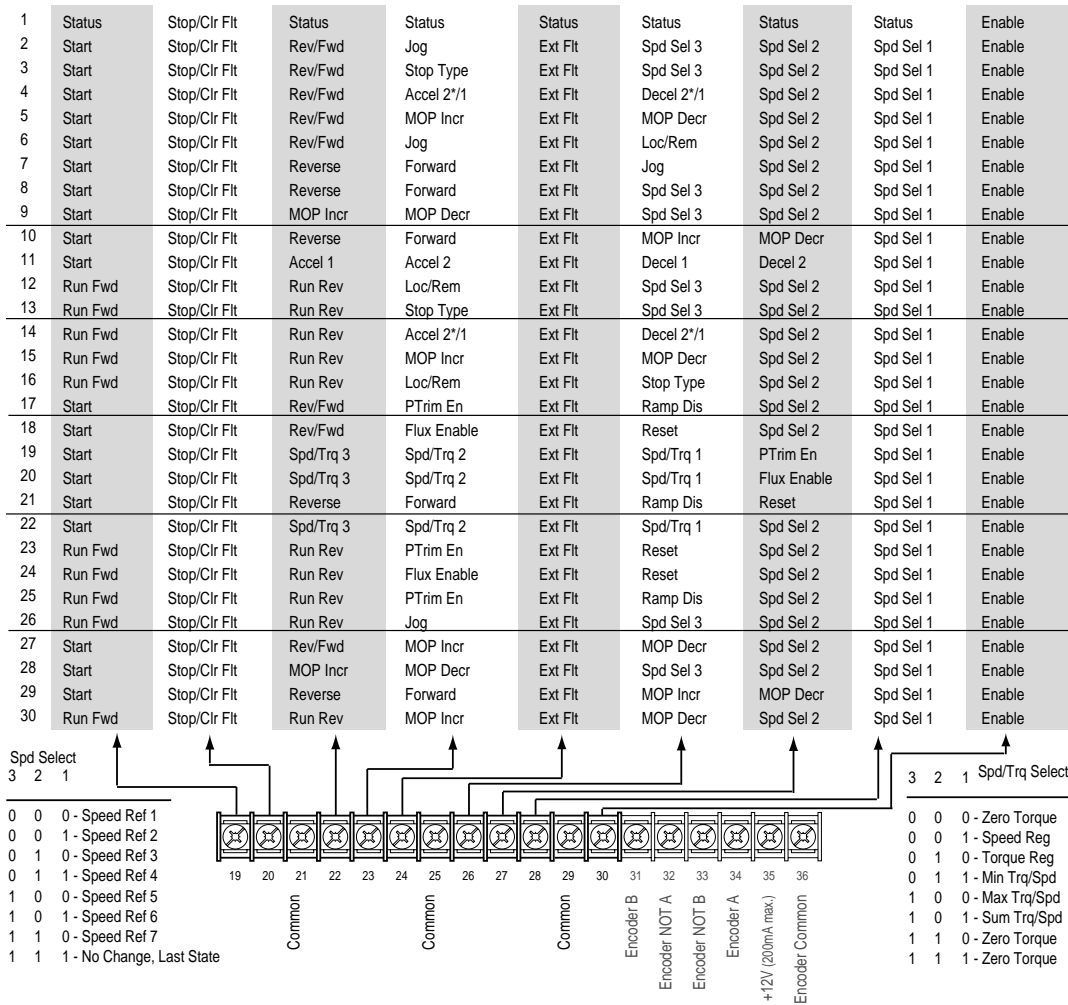

## Start-Up



This start-up procedure covers only the most commonly adjusted values using the 1336 IMPACT “Startup” mode. Refer to the User Manual for detailed information.

The following procedure is written for users who have a Human Interface Module (HIM) installed. For users without a HIM, respective external commands and signals must be supplied. It is also assumed that all parameters are at factory default settings.



**ATTENTION:** Power must be applied to the drive to perform the following. Some of the voltages present are at incoming line potential. To avoid a shock hazard or damage to equipment, only qualified drive service personnel should perform the following procedure. Thoroughly read and understand the procedure before beginning. If an event does not occur while performing this procedure, Do Not Proceed. Remove power by opening the branch circuit disconnect device and correct the malfunction before continuing.



**ATTENTION:** To avoid a hazard of electric shock when wiring or servicing the drive, verify that the voltage on the bus capacitors has discharged. Measure the DC bus voltage at the + and - terminals of TB1. The voltage must be zero.

1. Verify that AC line power and control power match the drive rating.
2. If an L option is installed, verify that the Stop and Enable interlock inputs are present. If this option is not installed, verify that jumpers are installed at pins 3 and 4 and 17 and 18 on J5 on A Frame drives or J2 on B Frame and up drives. Refer to Jumper Locations.
3. If standard I/O is being used, verify that jumpers are wired correctly.
4. If Analog Option is installed, verify that parameters are properly configured (refer to the User Manual).



**ATTENTION:** In all of the following steps, rotation of the motor may occur. To guard against injury, incorrect rotation, and possible equipment damage, read each step carefully and perform with caution.

5. Apply AC power and control voltages to the drive. The LCD display should light and display a drive status of “Stopped” and an output frequency of “+0.00 Hz.” If the drive detects a fault, a statement relating to the fault will be shown on the display. Record the information, remove power, and correct the fault source before proceeding.
6. From the Status Display, press the Enter key (or any key). “Choose Mode” will be displayed. Press the Increment (or Decrement) key until “Startup is displayed. Press Enter.

**Important:** All questions can be answered Yes or No. Pressing Enter will select the default (“Y” or “N”). Pressing the Increment (or Decrement) key will change the selection. Press Enter to select. Choosing “Y” allows you to proceed through the step, and choosing “No” will advance you to the next step. The figure below shows the steps involved.

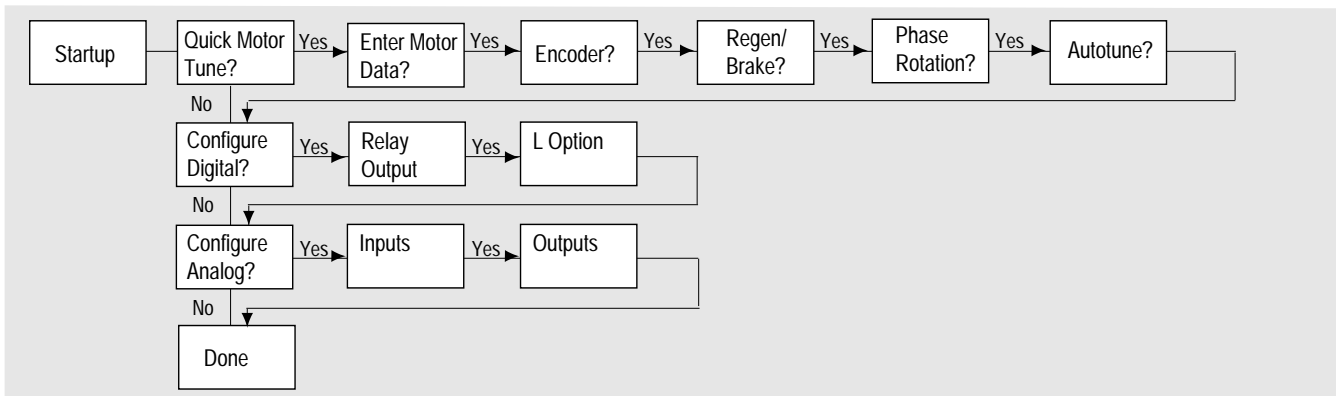

**Important:** Please note the following:

- The “Startup” mode can be exited at any time by pressing ESCape until the Status Display is shown. If you wish to re-enter the “Startup” mode, simply select “Reset Sequence” to start from the beginning. Selecting “Continue” allows you to resume from the point where you left off.
  - Completing the last action in any step will automatically take you to the next step.
  - Pressing SElect will activate line 2 of the display. This must be done for all values.
  - Press the Increment (or Decrement) key to adjust a value (skip if value is correct). Press Enter to store the value or retain existing value. Pressing Enter again will cause you to move to the next step (parameter)
7. Cycle power to activate changes. This completes the “Assisted Startup” procedure. Depending on your application, further parameter programming and/or “Advanced Startup” may be required. Refer to the User Manual for details.

## Drive Dimensions

To determine the size of your drive, refer to the following illustration and table.

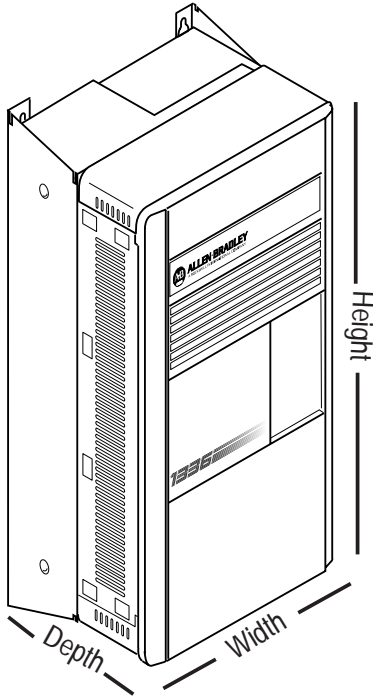

Frame	Width x Height x Depth Millimeters (inches)
A1	215.9 (8.50) x 290.0 (11.42) x 160.0 (6.30)
A2	215.9 (8.50) x 290.0 (11.42) x 180.5 (7.10)
A3	215.9 (8.50) x 290.0 (11.42) x 207.0 (8.15)
A4	260.0 (10.24) x 350.0 (13.78) x 212.0 (8.35)
B	276.4 (10.88) x 476.3 (18.75) x 225.0 (8.86)
C	301.8 (11.88) x 701.0 (27.60) x 225.0 (8.86)
D	381.5 (15.02) x 1240.0 (48.82) x 270.8 (10.66)
E-Enclosed	511.0 (20.12) x 1498.6 (59.00) x 477.5 (18.80)
E-Open	511.0 (20.12) x 1498.6 (59.00) x 372.6 (14.67)
F	762.0 (30.00) x 2286.0 (90.00) x 635.0 (25.00)
G	762.0 (30.00) x 2387.6 (94.0) x 635.0 (25.00)
H	1270.0 (50) x 2324.1 (91.50) <sup>①</sup> x 635.0 (25)

<sup>①</sup> Fan height (635.0 (25.00)) not included.

## HIM Operation

Parameter programming or viewing is accomplished through the Program or Display modes shown below.





1. From the Status Display, press  to display "Choose Mode."

2. Press  or  to display "Program" (or "Display").



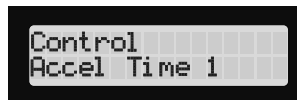

3. Press .

4. Press  or  until the desired file is displayed.





5. Press .

6. Press  or  until the desired group is displayed.



7. Press .

8. Press  or  to scroll to the desired parameter.

HIM Structure

[efesotomasyon.com](http://efesotomasyon.com)

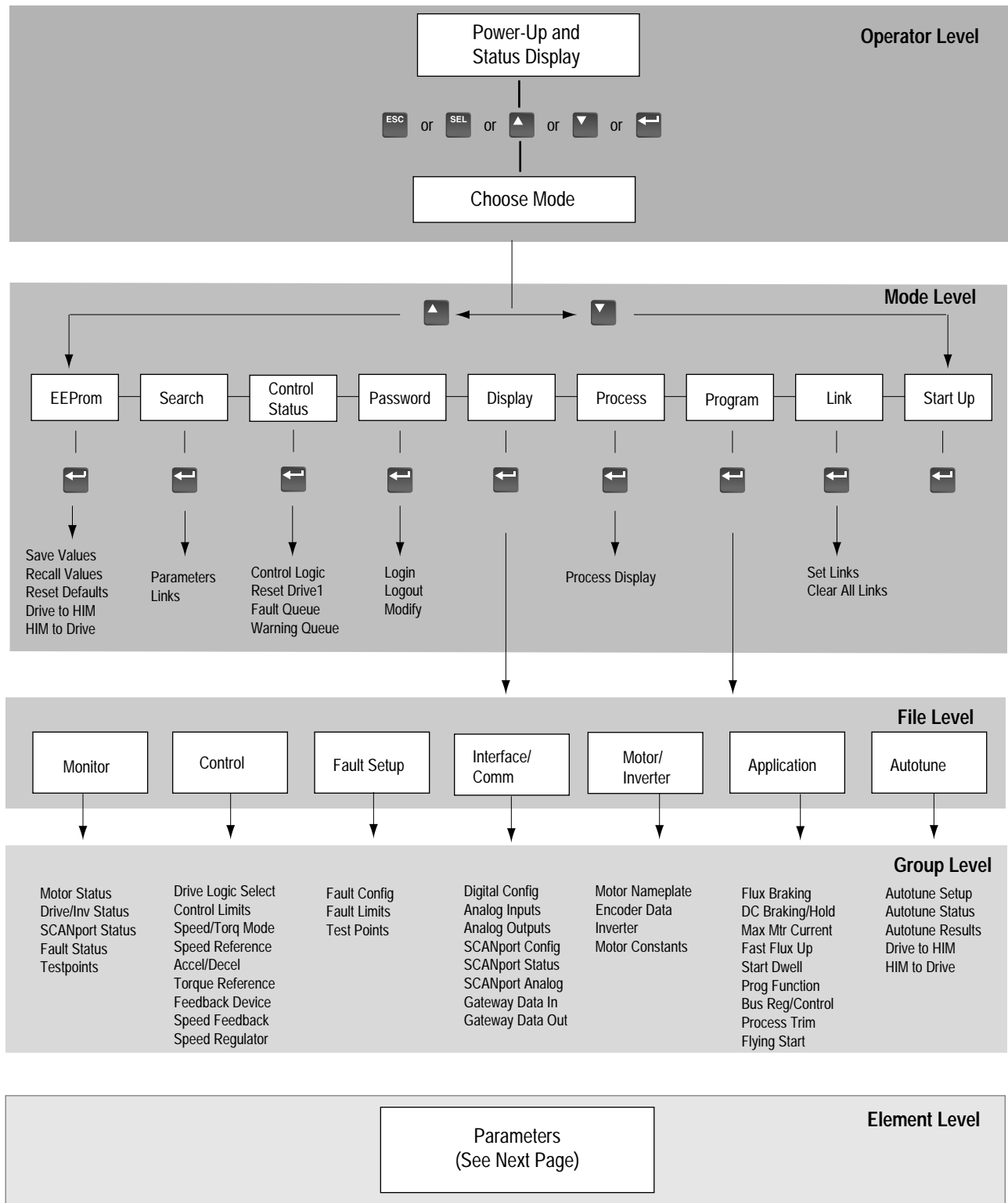

## Parameters - Files, Groups, and Elements

Name	No.	Min./Max. Value	Name	No.	Min./Max. Value
<b>Monitor</b>					
Motor Status			Neg Mtr Cur Lim 73 Calc/0.0%		
Motor Speed	81	-8 x BMS/+8 x BMS	Pos Torque Lim	74	0.0%/Calc
Motor Frequency	89	-250.000/+250.000 Hz	Neg Power Lim	75	Calc/0.0%
Motor Current	83	0.0/6553.5 amps	Regen Power Lim	76	-800.0%/0.0%
Motor Voltage	85	0/+3000 volts	Current Rate Lim	77	Calc/200.0%
Motor Voltage %	234	0/800%	Max Mtr Current	195	0/1
Motor Torque %	86	-800.0/+800.0%	Min Speed Limit	215	0.0/BMS rpm
Motor Flux %	88	12.5/100.0%	<b>Speed/Torq Mode</b>		
Motor Power%	90	-800.0/+800.0%	Spd/Trq Mode Sel	68	0/5
Enc Pos Fdbk Low	227	0/65535	<b>Speed Reference</b>		
Enc Pos Fdbk Hi	228	0/65535	Speed Ref 1	29	-8x/+8xBMS rpm
Int Torque Ref	229	-800/+800%	Speed Scale 1	30	-3.9999/+3.9999
<b>Drive/Inv Status</b>			Speed Ref 2	31	-8x/+8xBMS rpm
DC Bus Voltage	84	0/1000V	Speed Ref 3	32	-8x/+8xBMS rpm
Logic Input Sts	14	Bit selection	Speed Ref 4	33	-8x/+8xBMS rpm
Drive/Inv Status	15	Bit selection	Speed Ref 5	34	-8x/+8xBMS rpm
Drive/Inv Sts 2	196	Bit selection	Speed Ref 6	35	-8x/+8xBMS rpm
Run Inhibit Sts	16	Bit selection	Speed Ref 7	36	-8x/+8xBMS rpm
Command Spd Sts	82	-8 x BMS/+8 x BMS	Speed Scale 7	37	-3.9999/+3.9999
Torque Limit Sts	87	Bit selection	Jog Speed 1	38	-8x/+8xBMS rpm
Spd Reg Output	225	-300.0/+300.0%	Jog Speed 2	39	-8x/+8xBMS rpm
Spd Error	226	-8 x BMS/+8 x BMS	<b>Accel/Decel</b>		
<b>SCANport Status</b>			Accel Time 1	42	0.0/6553.5 sec
Dir/Ref Owner	128	Bit selection	Accel Time 2	43	0.0/6553.5 sec
Start/Stop Owner	129	Bit selection	Decel Time 1	44	0.0/6553.5 sec
Jog1/Jog2 Owner	130	Bit selection	Decel Time 2	45	0.0/6553.5 sec
Ramp/CIFit Owner	131	Bit selection	S-Curve Percent	47	0.0/100.0%
Flux/Trim Owner	132	Bit selection	<b>Torque Reference</b>		
<b>Fault Status</b>			Torque Ref 1	69	-800.0/+800.0%
PwrUp Flt Status	219	Bit selection	Slave Torque %	70	-200.00/+200.00%
Ncfg Flt Status	220	Bit selection	<b>Feedback Device</b>		
Fault Status 1	221	Bit selection	Fdbk Device Type	64	1/3
Fault Status 2	222	Bit selection	Encoder PPR	8	Calc/20000 ppr
Warning Status 1	223	Bit selection	<b>Speed Feedback</b>		
Warning Status 2	224	Bit selection	Scaled Spd Fdbk	63	-32767/+32767
<b>Testpoints</b>			Fdbk Filter Sel	65	0/4
Test Data 1	92	-32768/+32767	Fdbk Filter Gain	66	-5.00/+5.00
Test Select 1	93	0/65535	Fdbk Filter BW	67	0.2/900.0 rad/sec
Test Data 2	94	-32768/+32767	Notch Filtr Freq	185	5.0/135.0 Hz
Test Select 2	95	0/65535	Notch Filtr Q	186	2/500
<b>Control</b>			<b>Speed Regulator</b>		
Drive Logic Select			Total Inertia	157	0.01 sec/655.00 sec
Logic Options	17	Bit selections	Spd Desired BW	161	0.00 rad/sec/Calc
Stop Dwell Time	18	0.0/10.0 sec	Ki Speed Loop	158	0.0/4095.9
Zero Speed Tol	19	0.0 rpm/8xBMS rpm	Kp Speed Loop	159	0.0/200.0
Start Dwell Spd	193	-0.1/+0.1 x BMS	Kf Speed Loop	160	0.500/1.000
Start Dwell Time	194	0.0/10.0 sec	Error Filtr BW	162	Calc/1500.0 rad/sec
<b>Control Limits</b>			Droop Percent	146	0.0/25.5%
Rev Speed Limit	40	-6xBMS rpm/0.0 rpm	<b>Fault Setup</b>		
Fwd Speed Limit	41	0.0 rpm/+6xBMS rpm	Fault Config		
Pos Mtr Cur Lim	72	0.0%/Calc	Fault Select 1	20	Bit selection
			Warning Select 1	21	Bit selection

Name	No.	Min./Max. Value	Name	No.	Min./Max. Value
<b>Fault Config cont.</b>			<b>SCANport Config</b>		
Fault Select 2	22	Bit Selection	SP2 Wire Enable	181	Bit Selection
Warning Select 2	23	Bit Selection	SP Enable Mask	124	Bit Selection
<b>Fault Limits</b>			Dir/Ref Mask	125	Bit Selection
Absolute Overspd	24	0.0 rpm/BMS rpm	Start/Jog Mask	126	Bit Selection
Motor Stall Time	25	0.1/3276.7 sec	Clr Flt/Res Mask	127	Bit Selection
Motor Overload %	26	110.0/400.0%	<b>SCANport Status</b>		
Line Undervolts	27	10.0/90.0%	Dir/Ref Owner	128	Bit selection
<b>Testpoints</b>			Start/Stop Owner	129	Bit selection
Test Data 1	92	-32768/+32768	Jog1/Jog2	130	Bit selection
Test Select 1	93	0/65535	Ramp/CIFlt Owner	131	Bit selection
Test Data 2	94	-32768/+32767	Flux/Trim Owner	132	Bit selection
Test Select 2	95	0/65535	<b>SCANport Analog</b>		
<b>Interface/Comm</b>			SP An In1 Select	133	1/16
<b>Digital Config</b>			SP An In1 Value	134	-32767/+32767
Relay Config	114	0/38	SP An In1 Scale	135	-1.000/+1.000
Relay Config 1	115	-800.0/+800.0%	Sp An In2 Select	136	1/16
Relay Config 2	187	0/36	Sp An In2 Value	137	-32767/+32767
Relay Setpoint 2	188	800.0/+800.0	Sp An In2 Scale	138	-1.000/+1.000
Relay Config 3	189	0/36	Sp An Output	139	-32767/+32767
Relay Setpoint 3	190	-800.0/+800.0	<b>Gateway Data In</b>		
Relay Config 4	191	0/36	Data In A1	140	-32767/+32767
Relay Setpoint 4	192	-800/+800.0%	Data In A2	141	-32767/+32767
L Option Mode	116	1/25	Data In B1	142	-32767/+32767
L Option In Sts	117	Bit Selection	Data In B2	143	-32767/+32767
Mop Increment	118	0.0/BMS	Data In C1	144	-32767/+32767
Mop Value	119	0.0/BSMNA	Data In C2	145	-32767/+3276
Pulse In PPR	120	500/2000	Data In D1	146	-32767/+32767
Pulse In Scale	121	0.01/10.00	Data In D2	147	-32767/+32767
Pulse In Offset	122	-BMS/+BMS	<b>Gateway Data Out</b>		
Pulse In Value	123	0.0/+8xBMS	Data Out A1	148	-32767/+32767
<b>Analog Inputs</b>			Data Out A2	149	-32767/+32767
An In 1 Value	96	-32767/+32767	Data Out B1	150	-32767/+32767
An In 1 Offset	97	-19.980/+19.980 volts	Data Out B2	151	-32767/+32767
An In 1 Scale	98	-16.000/+16.000	Data Out C1	152	-32767/+32767
An In 1 Filter BW	182	0.0/200.0 rad/sec	Data Out C2	153	-32767/+32767
An In 2 Value	99	-32767/+32767	Data Out D1	154	-32767/+32767
An In 2 Offset	100	-19.980/+19.980 volts	Data Out D2	155	-32767/+32767
An In 2 Scale	101	-16.000/+16.000			
An In2 Filter BW	183	0.0/200.0 rad/sec			
mA Input Value	102	-32767/+32767			
mA In Offset	103	-32.000/+32.000 mA			
mA In Scale	104	-16.00			
mA In Filter BW	184	0.0/200.0 rad/sec			
<b>Analog Outputs</b>					
An Out 1 Value +0	105	-32767/+32767			
An Out 1 Offset	106	-20.000/+20.000			
An Out 1 Scale	107	-1.000/+1.000			
An Out 2 Value	108	-32767/+32767			
An Out 2 Offset	109	-19.980/+19.980 volts			
An Out 2 Scale	110	-1.000/+1.000			
mA Out Value	111	-32767/+32767			
mA Out Offset	112	-32.000/+32.000 mA			
mA Out Scale	113	-1.000/+1.000			

[efesotomasyon.com](http://efesotomasyon.com)

Name	No.	Min./Max. Value	Name	No.	Min./Max. Value
<b>Motor Inverter</b>			Function Sel	212	0/27
Motor Nameplate			Function Output1	213	Varies
Nameplate HP	2	0.2 hp/2000.0 hp	Function Output2	214	0/65535
Nameplate RPM	3	1 rpm/1500 rpm	Function In9	232	-32767/+32767
Nameplate Amps	4	0.1 amps/Calc	Function In 10	233	-32767/+32767
Nameplate Volts	5	75 volts/575 volts	<b>Bus Reg Control</b>		
Nameplate Hz	6	1.0/250.0 Hz	Bus/Brake Option	13	Bit selection
Motor Poles	7	2/40 poles	<b>Process Trim</b>		
Service Factor	9	1.00/2.00	PTrim Output	48	-800.0/+800.0%
<b>Encoder Data</b>			PTrim Reference	49	-800.0/+800.0%
Encoder PPR	8	Calc/2000 ppr	PTrim Feedback	50	-800.0/+800.0%
<b>Inverter</b>			PTrim Select	51	Bit selection
PWM Frequency	10	1000 Hz/From drive	PTrim Filter BW	52	0.0/240.0 rad/sec
Inverter Amps	11	0.1 amps/From drive	PTrim Preload	53	-800.0/+800.0%
Inverter Volts	12	75/575 volts	PTrim Ki	54	0.000/16.000
<b>Motor Constants</b>			PTrim Kp	55	0.000/16.000
Stator Resistance	166	0.00/100.00%	PTrim Lo Limit	58	-800.0/+800.0%
Leak Inductance	167	0.00/100.00%	PTrim Hi Limit	59	-800.0/+800.0%
Flux Current	168	0.00/75.00%	PTrim Out Gain	60	-8.000/+8.000
Slip Gain	169	0.0/400.0%	Max Rev Spd Trim	61	-6 x /0.0 BMS rpm
Motor Poles	7	2/40 poles	Max Fwd Spd Trim	62	0.0 rpm/+6xBMS rpm
<b>Application</b>			<b>Flying Start</b>		
Flux Braking			FStart Select	216	0/2
Bus/Brake Option	13	Bit selection	FStart Speed	217	P40/P41
<b>DC Braking/Hold</b>			<b>Autotune</b>		
Bus/Brake Option	13	Bit selection	Autotune Setup		
DC Brake Current	79	0.0%/Calc	Autotune/Dgn Sel	173	Bit selection
DC Brake Time	80	0.0/6553.5 sec	Trans Dgn Config	172	Bit selection
<b>400% Mtr Current</b>			Autotune Torque	64	250%/100.0%
Max Mtr Current	195	0/1	Autotune Speed	165	0.3 x BMS/BMS
<b>Fast Flux Up</b>			<b>Autotune Status</b>		
Bus/Brake Option	13	Bit selection	Autotune Status	156	Bit selection
Fast Flux Level	78	100.0%/Calc	Inverter Dgn 1	174	Bit selection
<b>Start Dwell</b>			Inverter Dgn 2	175	Bit selection
Start Dwell Spd	193	-0.1 x / +0.1 x BMS	Autotune Errors	176	Bit selection
Start Dwell Time	194	0.0/10.0 sec	<b>Autotune Results</b>		
<b>Prog Function</b>			Stator Resistance	166	0.00/100.00%
Function In1	198	Varies	Leak Inductance	167	0.00/100.00%
Func 1 Mask/Val	199	Varies	Flux Current	168	0.00/75.00%
Func 1 Eval Sel	200	0/17	Slip Gain	169	0.0/400%
Function In2	201	Varies	Total Inertia	157	0.0/655.00 sec
Func 2 Mask/Val	202	Varies	Spd Desired BW	161	0.00/Calc rad/sec
Func 2 Eval Sel	203	0/17			
Function In3	204	Varies			
Func 3 Mask/Val	205	Varies			
Func 3 Eval Sel	206	0/17			
Function In4	207	Varies			
Function In5	208	Varies			
Function In6	209	Varies			
Function In7	210	Varies			
Function In8	211	Bit selection			

This Page Intentionally Blank

# 1336 IMPACT Kurzanleitung

In dieser Kurzanleitung wird beschrieben, wie Sie den Frequenzumrichter 1336 IMPACT installieren, in Betrieb nehmen und programmieren. Die hierin enthaltenen Informationen sind jedoch kein Ersatz für das Benutzerhandbuch und sind nur für qualifiziertes FU-Wartungspersonal vorgesehen. Detaillierte Informationen über andere Anwendungsaspekte und die entsprechenden sicherheitstechnischen Hinweise finden Sie im 1336 IMPACT-Benutzerhandbuch (Publikation 1336 IMPACT-5.0).

## Verdrahtung der Netzanschlüsse – TB1

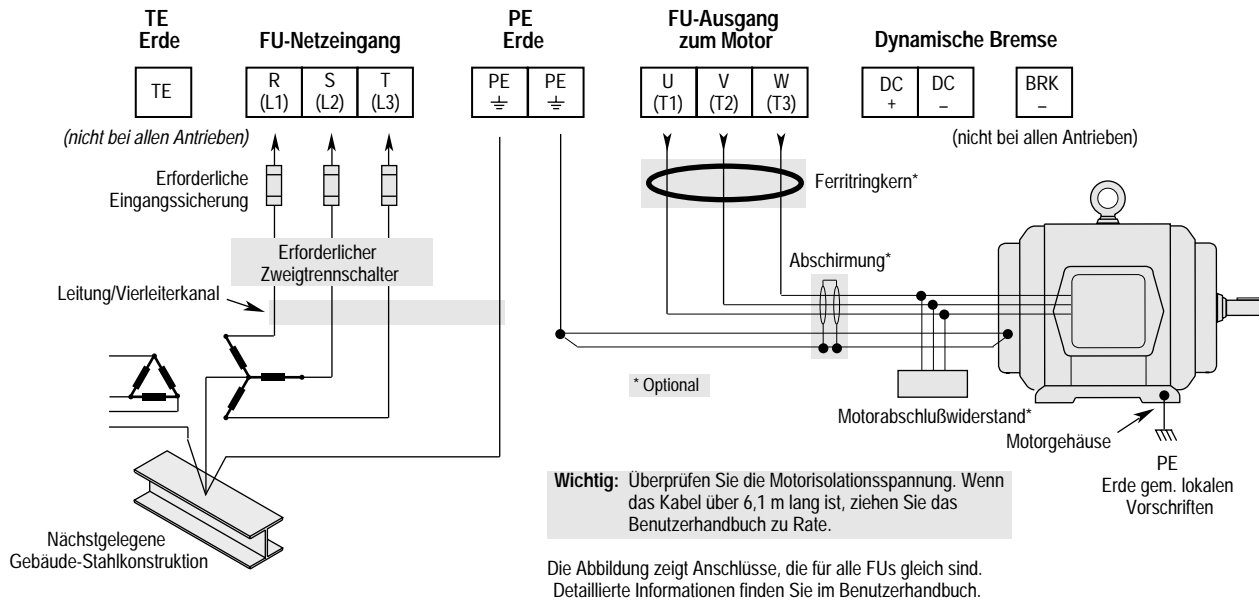

## Brückenpositionen

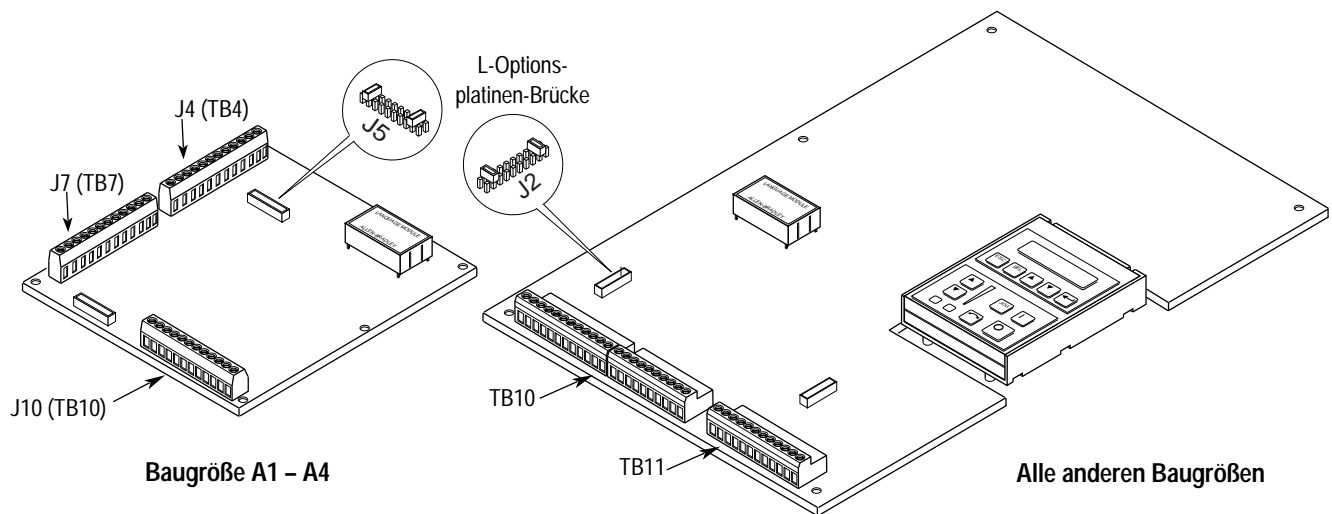

## Verdrahtungs-E/A – Baugröße A

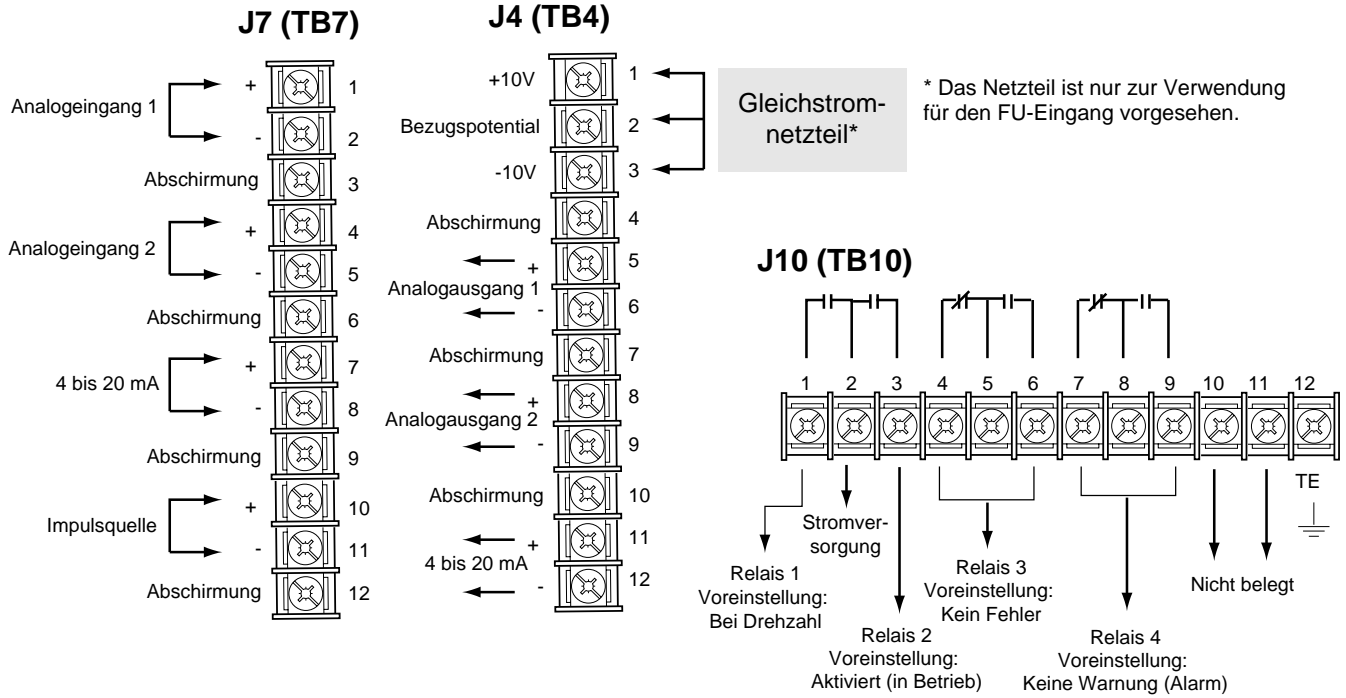

## Verdrahtungs-E/A – Alle anderen Baugrößen

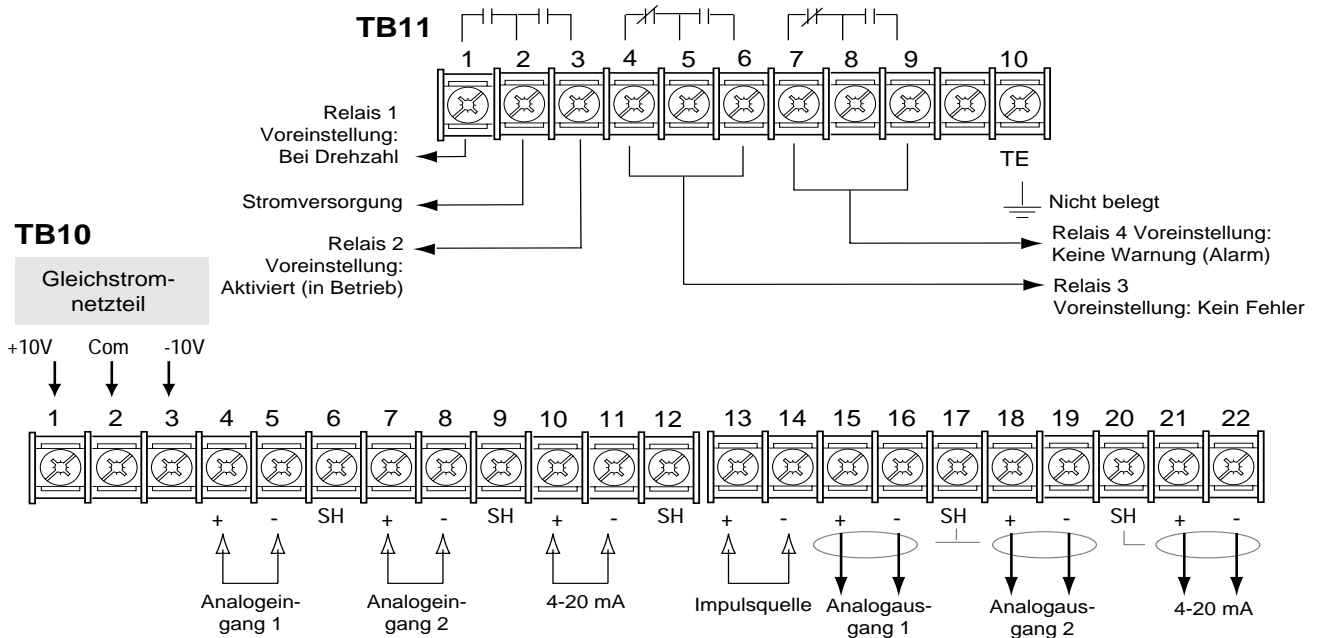

## L-Optionsplatine

1	Status	Stop/Alarm Löschen	Status	Status	Status	Status	Status	Status	Aktivieren
2	Start	Stop/Alarm Löschen	Rückw/Vorw	Probelauf	Ext.Alarm	Wahl Drz 3	Wahl Drz 2	Wahl Drz 1	Aktivieren
3	Start	Stop/Alarm Löschen	Rückw/Vorw	Anhalteart	Ext.Alarm	Wahl Drz 3	Wahl Drz 2	Wahl Drz 1	Aktivieren
4	Start	Stop/Alarm Löschen	Rückw/Vorw	Beschl 2*/1	Ext.Alarm	Bremse 2*/1	Wahl Drz 2	Wahl Drz 1	Aktivieren
5	Start	Stop/Alarm Löschen	Rückw/Vorw	Pot.Schritt	Ext.Alarm	Pot.Abnahme	Wahl Drz 2	Wahl Drz 1	Aktivieren
6	Start	Stop/Alarm Löschen	Rückw/Vorw	Probelauf	Ext.Alarm	Zentr/Dezent	Wahl Drz 2	Wahl Drz 1	Aktivieren
7	Start	Stop/Alarm Löschen	Rückwärts	Vorwärts	Ext.Alarm	Probelauf	Wahl Drz 2	Wahl Drz 1	Aktivieren
8	Start	Stop/Alarm Löschen	Rückwärts	Vorwärts	Ext.Alarm	Wahl Drz 3	Wahl Drz 2	Wahl Drz 1	Aktivieren
9	Start	Stop/Alarm Löschen	Pot.Schritt	Pot.Abnahme	Ext.Alarm	Wahl Drz 3	Wahl Drz 2	Wahl Drz 1	Aktivieren
10	Start	Stop/Alarm Löschen	Rückwärts	Vorwärts	Ext.Alarm	Pot.Schritt	Pot.Abnahme	Wahl Drz 1	Aktivieren
11	Start	Stop/Alarm Löschen	Beschl 1	Beschl 2	Ext.Alarm	Bremse 1	Bremse 2	Wahl Drz 1	Aktivieren
12	Vorwärts	Stop/Alarm Löschen	Rückw Lauf	Zentr/Dezent	Ext.Alarm	Wahl Drz 3	Wahl Drz 2	Wahl Drz 1	Aktivieren
13	Vorwärts	Stop/Alarm Löschen	Rückw Lauf	Anhalteart	Ext.Alarm	Wahl Drz 3	Wahl Drz 2	Wahl Drz 1	Aktivieren
14	Vorwärts	Stop/Alarm Löschen	Rückw Lauf	Beschl 2*/1	Ext.Alarm	Bremse 2*/1	Wahl Drz 2	Wahl Drz 1	Aktivieren
15	Vorwärts	Stop/Alarm Löschen	Rückw Lauf	Pot.Schritt	Ext.Alarm	Pot.Abnahme	Wahl Drz 2	Wahl Drz 1	Aktivieren
16	Vorwärts	Stop/Alarm Löschen	Rückw Lauf	Zentr/Dezent	Ext.Alarm	Anhalteart	Wahl Drz 2	Wahl Drz 1	Aktivieren
17	Start	Stop/Alarm Löschen	Rückw/Vorw	PTrim akt	Ext.Alarm	Rampe deak	Wahl Drz 2	Wahl Drz 1	Aktivieren
18	Start	Stop/Alarm Löschen	Rückw/Vorw	Fluß aktiv	Ext.Alarm	Rücksetzen	Wahl Drz 2	Wahl Drz 1	Aktivieren
19	Start	Stop/Alarm Löschen	Drz/Drm 3	Drz/Drm 2	Ext.Alarm	Drz/Drm 1	PTrim akt	Wahl Drz 1	Aktivieren
20	Start	Stop/Alarm Löschen	Drz/Drm 3	Drz/Drm 2	Ext.Alarm	Drz/Drm 1	Fluß aktiv	Wahl Drz 1	Aktivieren
21	Start	Stop/Alarm Löschen	Rückwärts	Vorwärts	Ext.Alarm	Rampe deak	Rücksetzen	Wahl Drz 1	Aktivieren
22	Start	Stop/Alarm Löschen	Drz/Drm 3	Drz/Drm 2	Ext.Alarm	Drz/Drm 1	Wahl Drz 2	Wahl Drz 1	Aktivieren
23	Vorwärts	Stop/Alarm Löschen	Rückw Lauf	PTrim akt	Ext.Alarm	Rücksetzen	Wahl Drz 2	Wahl Drz 1	Aktivieren
24	Vorwärts	Stop/Alarm Löschen	Rückw Lauf	Fluß aktiv	Ext.Alarm	Rücksetzen	Wahl Drz 2	Wahl Drz 1	Aktivieren
25	Vorwärts	Stop/Alarm Löschen	Rückw Lauf	PTrim akt	Ext.Alarm	Rampe deak	Wahl Drz 2	Wahl Drz 1	Aktivieren
26	Vorwärts	Stop/Alarm Löschen	Rückw Lauf	Probelauf	Ext.Alarm	Wahl Drz 3	Wahl Drz 2	Wahl Drz 1	Aktivieren
27	Start	Stop/Alarm Löschen	Rückw/Vorw	Pot.Schritt	Ext.Alarm	Pot.Abnahme	Wahl Drz 2	Wahl Drz 1	Aktivieren
28	Start	Stop/Alarm Löschen	Pot.Schritt	Pot.Abnahme	Ext.Alarm	Wahl Drz 3	Wahl Drz 2	Wahl Drz 1	Aktivieren
29	Start	Stop/Alarm Löschen	Rückwärts	Vorwärts	Ext.Alarm	Pot.Schritt	Pot.Abnahme	Wahl Drz 1	Aktivieren
30	Vorwärts	Stop/Alarm Löschen	Rückw Lauf	Pot.Schritt	Ext.Alarm	Pot.Abnahme	Wahl Drz 2	Wahl Drz 1	Aktivieren

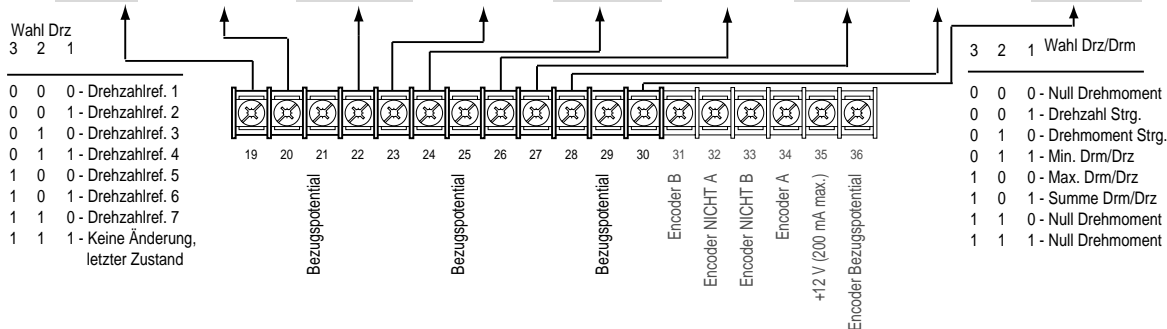

## Inbetriebnahme

Das hier beschriebene Inbetriebnahmeverfahren umfaßt nur die im 1336 IMPACT „Start“-Modus am häufigsten eingestellten Werte. Detailliertere Informationen finden Sie im Benutzerhandbuch.

Die folgenden Anleitungen gelten für Benutzer, die eine Bedieneinheit (HIM) verwenden. Wenn keine Bedieneinheit installiert ist, sind die entsprechenden externen Befehle und Signale erforderlich. Ferner wird davon ausgegangen, daß die werkseitig eingestellten Parameter verwendet werden.



**ACHTUNG:** Zur Durchführung der folgenden Schritte muß der FU mit Strom versorgt werden. Hierbei ist zu beachten, daß die Netzspannung anliegen kann. Um der Gefahr eines elektrischen Schlags oder eines Geräteschadens vorzubeugen, sollten die folgenden Schritte nur von qualifiziertem Wartungspersonal durchgeführt werden. Lesen Sie zuerst die nachstehenden Anleitungen. Wenn ein hierin beschriebenes Ereignis bei der Durchführung dieses Verfahrens nicht eintritt, fahren Sie nicht fort. Schalten Sie die Stromzufuhr durch Öffnen des Leistungsschalters aus, und beheben Sie den Fehler.



**ACHTUNG:** Um der Gefahr eines elektrischen Schlags bei der Durchführung von Wartungsarbeiten vorzubeugen, überprüfen Sie, ob die Buskondensatoren entladen wurden. Messen Sie die Zwischenkreisspannung an der + und - Klemme von TB1. Die Spannung muß Null betragen.

1. Überprüfen Sie, ob die Netzspannung und die Steuerspannung der FU-Nennleistung entsprechen.
2. Falls eine L-Option installiert wurde, überprüfen Sie, ob die Stopp- und Freigabeeingänge vorhanden sind. Wurde diese Options nicht installiert, überprüfen Sie, ob die Brücken bei FUs der Baugröße A an den Stiften 3 und 4 sowie 17 und 18 von J5 bzw. bei FUs der Baugröße B und höher von J2 angebracht wurden. Siehe „Brückenpositionen“.
3. Bei Verwendung von Standard-E/A überprüfen Sie, ob die Brücken ordnungsgemäß angebracht wurden.
4. Wurde eine Analogoptionskarte installiert, überprüfen Sie, ob die Parameter ordnungsgemäß konfiguriert sind (siehe Benutzerhandbuch).



**ACHTUNG:** Bei allen nachstehend beschriebenen Schritten kann es zur Drehung des Motors kommen. Um Verletzungen, falscher Drehrichtung bzw. einem Geräteschaden vorzubeugen, lesen Sie alle Schritte genau, und lassen Sie Vorsicht walten.

5. Schalten Sie die Netz- und Steuerspannung ein. Jetzt sollte die LED-Anzeige leuchten und den FU-Status „Gestoppt“ sowie die Ausgangsfrequenz „+0,00 Hz“ anzeigen. Wenn der FU einen Fehler feststellt, wird eine entsprechende Meldung eingeblendet. Zeichnen Sie die eingeblendeten Informationen auf, schalten Sie die Stromzufuhr aus, und beheben Sie den Fehler, bevor Sie fortfahren.
6. Drücken Sie bei eingeblendeter Statusanzeige die Eingabetaste (oder eine beliebige andere Taste). Jetzt wird „Modus wählen“ eingeblendet. Drücken Sie die Aufwärts- oder Abwärtstaste, bis „Inbetriebnahme“ angezeigt wird. Drücken Sie die Eingabetaste.

**Wichtig:** Alle Fragen können mit Ja oder Nein beantwortet werden. Durch Drücken der Eingabetaste wird der Vorgabewert gewählt („Ja“ oder „Nein“). Durch Drücken der Aufwärts- oder Abwärtstaste wird der Wert geändert - drücken Sie die Eingabetaste, um die entsprechende Auswahl anzunehmen. Wenn Sie „Ja“ drücken, fahren Sie mit dem jeweiligen Schritt fort. Wenn Sie „Nein“ drücken, gelangen Sie zum nächsten Schritt. In der nachfolgenden Abbildung werden die einzelnen Schritte dargestellt.

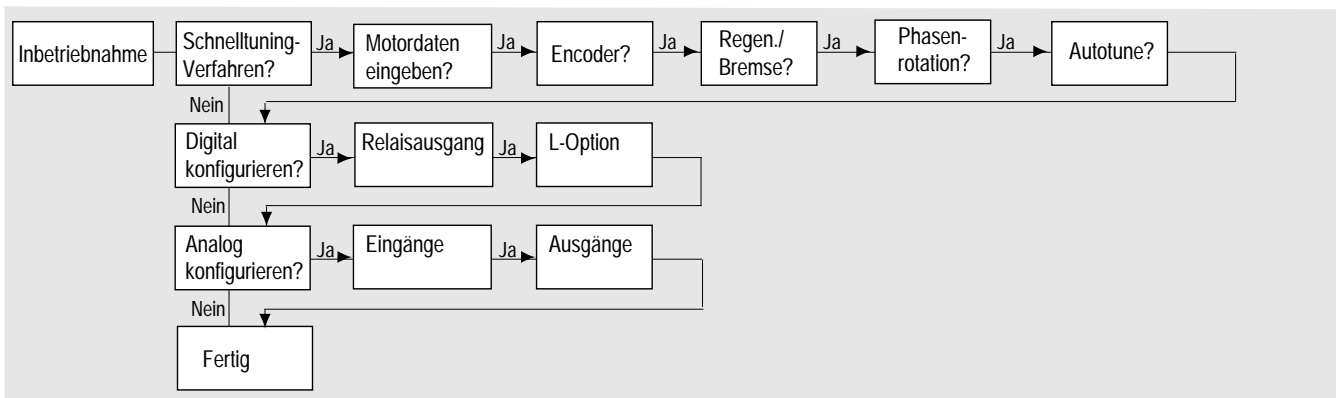

**Wichtig:** Bitte die folgenden Hinweise beachten:

- Der Modus „Inbetriebnahme“ kann jederzeit beendet werden, indem die ESC-Taste gedrückt wird, bis die Statusanzeige erscheint. Soll wieder in den Modus „Inbetriebnahme“ gewechselt werden, einfach „Rücksetzfolge“ auswählen, um nochmals von vorne zu beginnen. Durch Auswahl von „Weiter“ kann das Verfahren an dem Punkt wiederaufgenommen werden, an dem es abgebrochen wurde.
- Wenn ein Schritt abgeschlossen ist, gelangen Sie automatisch zum nächsten Schritt.
- Durch Drücken von „Auswählen“ wird Zeile 2 der Anzeige aktiviert. Dies muß für alle Werte erfolgen.
- Mit den Aufwärts- oder Abwärtstasten kann ein bestimmter Wert gewählt werden (Wenn der Wert bereits richtig ist, diesen Schritt auslassen). Danach die Eingabetaste drücken, um den Wert zu speichern oder den vorhandenen Wert beizubehalten. Durch erneutes Betätigen der Eingabetaste wird zum nächsten Schritt (Parameter) übergeleitet.

7. Das Gerät aus- und wieder einschalten, um die vorgenommenen Änderungen zu aktivieren. Damit ist das Inbetriebnahmeverfahren beendet. Je nach Anwendung können eine weitere Parameterprogrammierung und/oder eine erweiterte Inbetriebnahme erforderlich sein. Einzelheiten finden Sie im Benutzerhandbuch.

## FU-Abmessungen

Ziehen Sie zur Feststellung der Größe des Frequenzumrichters die folgende Abbildung und Tabelle zu Rate.

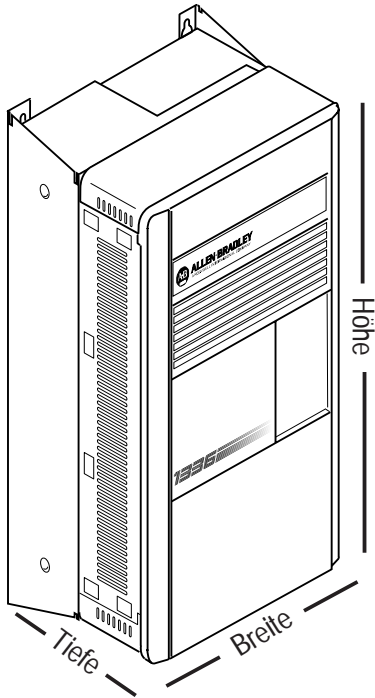

Baugröße	Breite x Höhe x Tiefe Millimeter
A1	215,9 x 290,0 x 160,0
A2	215,9 x 290,0 x 180,5
A3	215,9 x 290,0 x 207,0
A4	260,0 x 350,0 x 212,0
B	276,4 x 476,3 x 225,0
C	301,8 x 701,0 x 225,0
D	381,5 x 1240,0 x 270,8
E (IP20)	511,0 x 1498,6 x 477,5
E (IP00)	511,0 x 1498,6 x 372,6
F	762,0 x 2286,0 x 635,0
G	762,0 x 2387,6 x 635,0
H	1270,0 x 2324,1 <sup>①</sup> x 635,0

<sup>①</sup> Lüfterhöhe (635,0) nicht inbegriffen

## Bedieneinheit (HIM)

Das Programmieren (oder Lesen) der Parameter erfolgt über den nachfolgend abgebildeten Programmier- bzw. Anzeigemodus.



1. Auf der Statusanzeige drücken, um „Modus wählen“ anzuzeigen.
2. oder drücken, um „Programmieren“ (oder „Anzeigen“) anzuzeigen.



3. drücken.
4. oder drücken, bis die gewünschte Datei angezeigt wird.



5. drücken.
6. oder drücken, bis die gewünschte Gruppe angezeigt wird.



7. drücken.
8. oder drücken, um den gewünschten Parameter zu wählen.

## Struktur der Bedieneinheit (HIM)

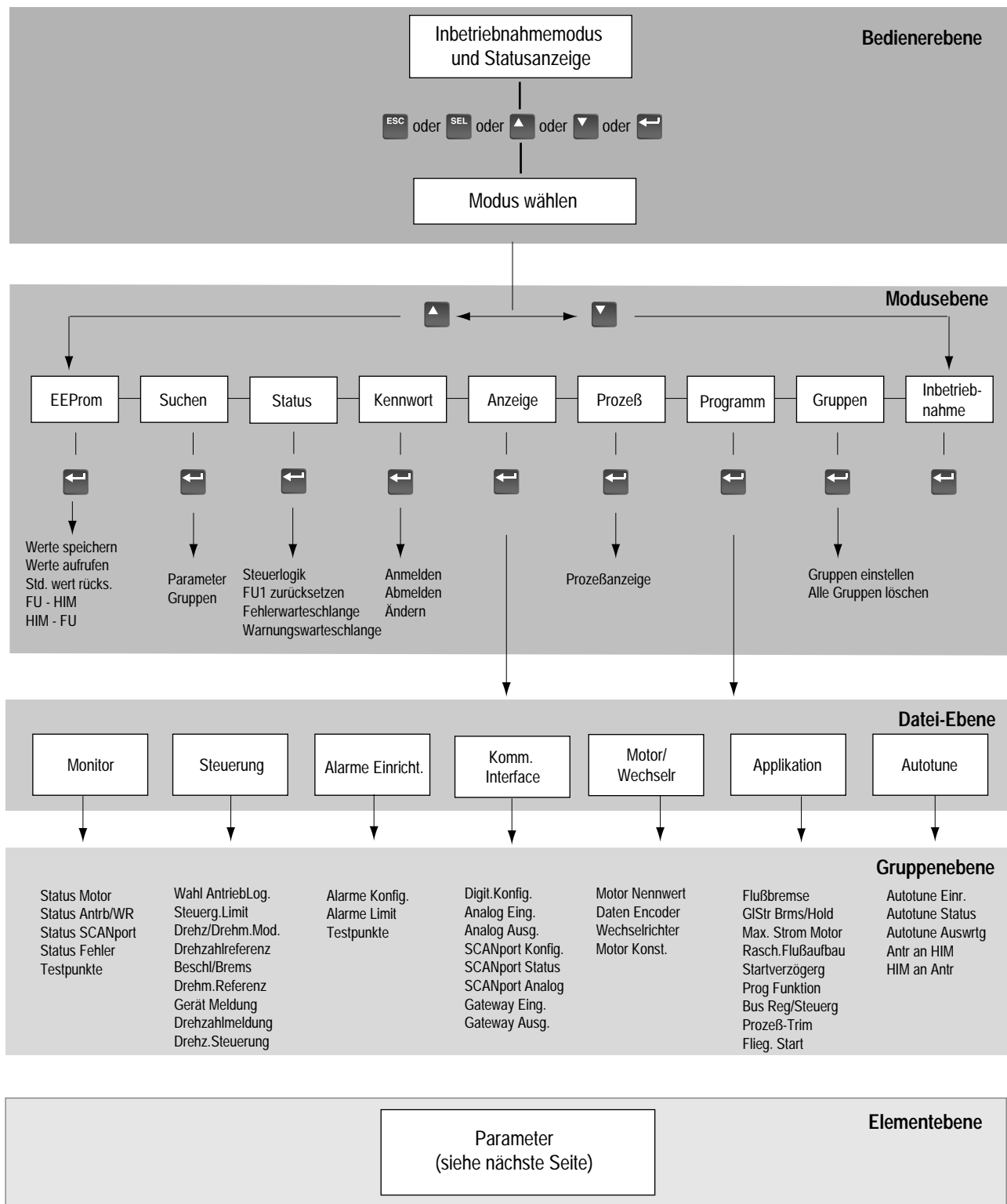

## Parameter – Dateien, Gruppen und Elemente

Bezeichnung	Nr.	Min./Max. Wert	Bezeichnung	Nr.	Min./Max. Wert
<b>Monitor</b>			Max.Neg.Mtrspng	73	Kalk/0,0%
Motorstatus			Pos.Drehm.Limit	74	0,0%/Kalk.
Motordrehzahl	81	-8 x BMS/+8 x BMS	Neg.Drehm.Limit	75	Kalk/0,0%
Motorfrequenz	89	-250,000/+250,000 Hz	Reg.Spann.Limit	76	-800,0%/0,0%
Strom Motor	83	0,0/6553,5 A	Max.Stromveränd	77	Kalk/200,0%
Motorspannung	85	0/+3000 V	Max.Strom Motor	195	0/1
Motorspannung %	234	0/800%	Mindestdrehzahl	215	0,0/ BMS U/Min.
Motordrehmom. %	86	-800,0/+800,0%	<b>Drehz/Drehm.Mod</b>		
Motorfluß %	88	12,5/100,0%	Drehz/Drehm Wahl	68	0/5
Motor Leistung %	90	-800,0/+800,0%	<b>Drehzahlreferenz</b>		
Enc.Pos.Mldg. niedr	227	0/65535	Drehz.Ref.1	29	-8x/+8xBMS U/Min.
Enc.Pos.Mldg. hoch	228	0/65535	Drehz.Faktor 1	30	-3,9999/+3,9999
Int. Drehmomentref.	229	-800/+800%	Drehz.Ref.2	31	-8x/+8xBMS U/Min.
<b>Status Antrieb/Wechselrichter</b>			Drehz.Ref.3	32	-8x/+8xBMS U/Min.
Spanng.GS-Bus	84	0/1000 V	Drehz.Ref.4	33	-8x/+8xBMS U/Min.
Stat.Log.Eingabe	14	Bitwahl	Drehz.Ref.5	34	-8x/+8xBMS U/Min.
Stat.Antr/Wchsrlr	15	Bitwahl	Drehz.Ref.6	35	-8x/+8xBMS U/Min.
Stat.Antr/Wslr2	196	Bitwahl	Drehz.Ref.7	36	-8x/+8xBMS U/Min.
Störungsgrund	16	Bitwahl	Drehz.Faktor 7	37	-3,9999/+3,9999
Komm.Drehz.St	82	-8 x BMS/+8 x BMS	Probelauf Drz 1	38	-8x/+8xBMS U/Min.
Drehm.Begr.Stats	87	Bitwahl	Probelauf Drz 2	39	-8x/+8xBMS U/Min.
Drehzahlreg.Ausg.	225	-300,0/+300,0%	<b>Beschl/Brems</b>		
Drehz.Alarm	226	-8 x BMS/+8 x BMS	Beschl.dauer 1	42	0,0/6553,5 s
<b>SCANport Status</b>			Beschl.dauer 2	43	0,0/6553,5 s
Richtg./Steurg.	128	Bitwahl	Bremsdauer 1	44	0,0/6553,5 s
Start/Anh.	129	Bitwahl	Bremsdauer 2	45	0,0/6553,5 s
Probel1/Probel2	130	Bitwahl	Prozent S-Kurve	47	0,0/100,0%
Rampe/Al.Lösch	131	Bitwahl	<b>Drehmomentreferenz</b>		
Fluß/Trim	132	Bitwahl	Drehm.Ref. 1	69	-800,0/+800,0%
<b>Fehlerstatus</b>			Drehm. Slave%	70	-200,00/+200,00%
Start Fehler.Stat.	219	Bitwahl	<b>Meldegerät</b>		
Neg Fehler.Stat.	220	Bitwahl	Art Meldungsger.	64	1/3
Fehlerstatus 1	221	Bitwahl	Encoder PPU	8	Kalk./20000 ppu
Fehlerstatus 2	222	Bitwahl	<b>Drehzahlmeldung</b>		
Warnstatus 1	223	Bitwahl	Drehzhmld.Faktr	63	-32767/+32767
Warnstatus 2	224	Bitwahl	Wahl Meld.Filter	65	0/4
<b>Testpunkte</b>			Verst.Meld.Filt.	66	-5,00/+5,00
Daten Test 1	92	-32768/+32767	Meld.Filter BB	67	0,2/900,0 rad/s
Wahl Test 1	93	0/65535	Freq.Kerbfilter	185	5,0/135,0 Hz
Daten Test 2	94	-32768/+32767	BereichKerbfiltr	186	2/500
Wahl Test 2	95	0/65535	<b>Drehzahlsteuerung</b>		
<b>Steuerung</b>			Gesamträgheit	157	0,01 s/655,00 s
Wahl Antriebslogik			Bandbr.Regelschw	161	0,00 rad/s/Kalk.
Optionen Logik	17	Bitwahl	Dämpf.i.Reglschw	158	0,0/4095,9
Verzögerg.Anh.	18	0,0/10,0 s	Dämpf.p.Reglschw	159	0,0/200,0
Tol.Nullgeschw.	19	0,0 U/Min/8xBMS U/Min.	Dämpf.f.Reglschw	160	0,500/1,000
Startverz.Drehz	193	-0,1/+0,1 x BMS	Bandbr.Abweichg.	162	Kalk/1500,0 rad/s
Startverz.Dauer	194	0,0/10,0 s	Drosselung in %	146	0,0/25,5%
<b>Steuerungslimits</b>			<b>Alarmerichtung</b>		
DrehzLimit Rückw	40	-6xBMS U/min./0,0 U/min.	Alarmer Konfig.		
Drehz.Limit Vorw	41	0,0 U/Min/+6xBMS U/Min.	Fehlerwahl 1	20	Bitwahl
Max.Pos.Mtrspng	72	0,0%/Kalk.	Alarmwahl 1	21	Bitwahl

1336 IMPACT Kurzanleitung

Bezeichnung	Nr.	Min./Max. Wert	Bezeichnung	Nr.	Min./Max. Wert
<b>Alarmer Konfig. (Forts.)</b>			<b>SCANport Konfig.</b>		
Fehlerwahl 2	22	Bitwahl	SCANport 2 Kabel	181	Bitwahl
Alarmwahl 2	23	Bitwahl	SCANPort ein/aus	124	Bitwahl
<b>Alarmer Limit</b>			Richtg./Referenz	125	Bitwahl
Drz.absol.überschr	24	0,0 U/Min./BMS U/Min.	Start/Probelauf	126	Bitwahl
Verz.Störung	25	0,1/3276,7 s	Al.Lösch/M.Rücks	127	Bitwahl
Überbelastung %	26	110,0/400,0%	<b>SCANport Status</b>		
Netz-Unterspann.	27	10,0/90,0%	Richtg./Referenz	128	Bitwahl
<b>Testpunkte</b>			Start/Anh.	129	Bitwahl
Daten Test 1	92	-32768/+32768	Prob1/Prob2	130	Bitwahl
Wahl Test 1	93	0/65535	Rampe/Al.Lösch	131	Bitwahl
Daten Test 2	94	-32768/+32767	Fluß/Trim	132	Bitwahl
Wahl Test 2	95	0/65535	<b>SCANport Analog</b>		
<b>Komm.Interface</b>			Wahl SP.Anal.E1	133	1/16
<b>Digit.Konfig.</b>			Wert SP.Anal.E1	134	-32767/+32767
Relay Konfig 1	114	0/38	Fakt.SP.Anal.E1	135	-1,000/+1,000
Relay Wert 1	115	-800,0/+800,0%	Wahl SP.Anal.E2	136	1/16
Relay Konfig.2	187	0/36	Wert SP.Anal.E2	137	-32767/+32767
Relay Wert 2	188	-800,0/+800,0	Fakt.SP.Anal.E2	138	-1,000/+1,000
Relay Konfig.3	189	0/36	ScP Anal.Ausg.	139	-32767/+32767
Relay Wert 3	190	-800,0/+800,0	<b>Gateway Eing.</b>		
Relay Konfig. 4	191	0/36	Daten Eing. A1	140	-32767/+32767
Relay Wert 4	192	-800,0/+800,0%	Daten Eing. A2	141	-32767/+32767
L-Option Modus	116	1/25	Daten Eing. B1	142	-32767/+32767
L-Opt.Eing.Stat.	117	Bitwahl	Daten Eing. B2	143	-32767/+32767
Pot.Schritt	118	0,0/BMS	Daten Eing. C1	144	-32767/+32767
Pot.Wert	119	0,0/BSMNA	Daten Eing. C2	145	-32767/+32767
Pulse Eing.PPU	120	500/2000	Daten Eing. D1	146	-32767/+32767
Pulse Eing.Fakt.	121	0,01/10,00	Daten Eing. D2	147	-32767/+32767
Pulse Eing.Vers.	122	-BMS/+BMS	<b>Gateway Ausg.</b>		
Pulse Eing.Wert	123	0,0/+8xBMS	Daten Ausg. A1	148	-32767/+32767
<b>Analogeingänge</b>			Daten Ausg. A2	149	-32767/+32767
Anal.Eing.Wert 1	96	-32767/+32767	Daten Ausg. B1	150	-32767/+32767
Anal.Eing.Vers.1	97	-19,980/+19,980 V	Daten Ausg. B2	151	-32767/+32767
Anal.Eing.Fakt.1	98	-16,000/+16,000	Daten Ausg. C1	152	-32767/+32767
BB.Filtr Anal.E1	182	0,0/200,0 rad/s	Daten Ausg. C2	153	-32767/+32767
Anal.Eing.Wert 2	99	-32767/+32767	Daten Ausg. D1	154	-32767/+32767
Anal.Eing.Vers.2	100	-19,980/+19,980 V	Daten Ausg. D2	155	-32767/+32767
Anal.Eing.Fakt.2	101	-16,000/+16,000			
BB.Filtr Anal.E2	183	0,0/200,0 rad/s			
mA Eing. Wert	102	-32767/+32767			
mA Eing. Vers.	103	-32,000/+32,000 mA			
mA Eing. Faktor	104	-16,00			
BB.Filtr mA. Eing	184	0,0/200,0 rad/s			
<b>Analogausgänge</b>					
Anal.Ausg.Wert 1 +0	105	-32767/+32767			
Anal.Ausg.Vers.1	106	-20,000/+20,000			
Anal.Ausg.Fakt.1	107	-1,000/+1,000			
Anal.Ausg.Wert 2	108	-32767/+32767			
Anal.Ausg.Vers.2	109	-19,980/+19,980 V			
Anal.Ausg.Fakt.2	110	-1,000/+1,000			
mA Ausg.Wert	111	-32767/+32767			
mA Ausg.Vers.	112	-32,000/+32,000 mA			
mA Ausg.Faktor	113	-1,000/+1,000			

Bezeichnung	Nr.	Min./Max. Wert	Bezeichnung	Nr.	Min./Max. Wert
<b>Motorwechselrichter</b>			Eval. Wahl	212	0/27
Motor Nennwert			Ausg.1 Eval	213	Variiert
Nenn-PS	2	0,2 PS/2000,0 PS	Ausg.2 Eval	214	0/65535
Nenn-U/Min	3	1 U/Min./1500 U/Min.	Eing.9 Eval.	232	-32767/+32767
Nenn-Amp.	4	0,1 A/Kalk.	Eing.10 Eval.	233	-32767/+32767
Nenn-Volt	5	75 V/575 V	<b>Bus Reg/Steurg</b>		
Nenn-Hz	6	1,0/250,0 Hz	Opt. Bus/Bremse	13	Bitwahl
Pole d. Motors	7	2/40 Pole	<b>Prozeß-Trim</b>		
Servicefaktor	9	1,00/2,00	PTrim Ausgabe	48	-800,0/+800,0%
<b>Daten Encoder</b>			PTrim Referenz	49	-800,0/+800,0%
Encoder PPU	8	Kalk./2000 ppu	PTrim Meldung	50	-800,0/+800,0%
<b>Wechselrichter</b>			PTrim Wahl	51	Bitwahl
PWM-Frequenz	10	1000 Hz/Vom Antrieb	PTrim Filter BB	52	0,0/240,0 rad/s
Amp Wechs.richt	11	0,1 Hz/Vom Antrieb	PTrim Voreinst.	53	-800,0/+800,0%
Volt Wechs.richt	12	75/575 V	PTrim Dämpf.i	54	0,000/16,000
<b>Motor Konst.</b>			PTrim Dämpf.p	55	0,000/16,000
Widerstnd.Stator	166	0,00/100,00%	PTrim Min.	58	-800,0/+800,0%
Indukt.Verlust	167	0,00/100,00%	PTrim Max.	59	-800,0/+800,0%
Flußstrom	168	0,00/75,00%	Verst.PTrim Ausg	60	-8,000/+8,000
Schlupfkorr.	169	0,0/400,0%	Max.Trim Rück.	61	-6 x/0,0 BMS U/Min.
Pole d. Motors	7	2/40 Pole	Max.Trim Vorw.	62	0,0 U/Min/+6xBMS U/Min.
<b>Applikation</b>			<b>Fliegender Start</b>		
Flußbremse			Wahl FStart	216	0/2
Opt. Bus/Bremse	13	Bitwahl	Drehz FStart	217	P40/P41
<b>GI Str Brms/Hold</b>			<b>Autotune</b>		
Opt. Bus/Bremse	13	Bitwahl	<b>Autotune Einr.</b>		
Gleichstrombremse	79	0,0%/Kalk.	Wahl Autot/Diagn	173	Bitwahl
GS.Bremsdauer	80	0,0/6553,5 s	Deakt.TransDiag	172	Bitwahl
<b>400% Mtr.Strom</b>			Drehm.f.Autotest	164	250%/100,0%
Max.Strom Motor	195	0/1	Drehz.f.Autotest	165	0,3 x BMS/BMS
<b>Rasch.Flußaufbau</b>			<b>Autotune Status</b>		
Opt. Bus/Bremse	13	Bitwahl	Autotune Status	156	Bitwahl
LimitRschFlußaufb	78	100,0%/Kalk.	WechsR.Diag 1	174	Bitwahl
<b>Startverzögerger</b>			WechsR.Diag 2	175	Bitwahl
Startverz.Drehz	193	-0,1 x / +0,1 x BMS	Autotune-Fehler	176	Bitwahl
Startverz.Dauer	194	0,0/10,0 s	<b>Autotune Auswrtg</b>		
<b>Prog Funktion</b>			Widerstnd.Stator	166	0,00/100,00%
Eing.1 Eval	198	Variiert	Indukt.Verlust	167	0,00/100,00%
E1Eval Mske/Wrte	199	Variiert	Flußstrom	168	0,00/75,00%
E1 Eval.Wahl	200	0/17	Schlupfkorr.	169	0,0/400%
Eing.2 Eval	201	Variiert	Gesamtträgheit	157	0,0/655,00 s
E2Eval Mske/Wrte	202	Variiert	Bandbr.Regelschw	161	0,00/Kalk. rad/s
E2 Eval.Wahl	203	0/17			
Eing.3 Eval	204	Variiert			
E3Eval Mske/Wrte	205	Variiert			
E3 Eval.Wahl	206	0/17			
Eing.4 Eval.	207	Variiert			
Eing.5 Eval.	208	Variiert			
Eing.6 Eval.	209	Variiert			
Eing.7 Eval.	210	Variiert			
Eing.8 Eval.	211	Bitwahl			

Raum für Notizen



---

Sie finden uns im Internet unter [www.rockwellautomation.com](http://www.rockwellautomation.com)

Rockwell Automation ist weltweit für Sie da und vereint führende Marken der industriellen Automation. Wir bieten Ihnen Steuerungen von Allen-Bradley, Antriebskomponenten von Reliance Electric, mechanische Antriebsselemente von Dodge sowie Software-Produkte von Rockwell Software. Rockwell Automation sichert Ihren Wettbewerbsvorteil durch Flexibilität und mit der Unterstützung von zahlreichen autorisierten Partnern, Distributoren und Systemintegratoren weltweit.

**Weltweite Hauptverwaltung**, 1201 South Second Street, Milwaukee, WI 53204, USA, Tel: (1) 414 382-2000, Fax: (1) 414 382-4444  
**Hauptverwaltung Europa**, 46, Avenue Debroux, 1160 Brüssel, Belgien, Tel: (32) 2 663 06 00, Fax: (32) 2 663 06 40  
**Hauptverwaltung Deutschland**, Düsseldorfberger Straße 15, 42781 Haan-Gruiten, Tel: (49) 2104 9600, Fax: (49) 2104 960121  
**Verkaufszentrum Schweiz**, Hintermattlistraße 3, 5506 Mägenwil, Tel: (41) 62 889 77 77, Fax: (41) 62 889 77 66  
**Hauptverwaltung Österreich**, Bäckermühlweg 1, 4030 Linz, Tel: (43) (732) 38 909 0, Fax: (43) (732) 38 909 61



**Rockwell  
Automation**

# Guide de mise en route rapide du variateur 1336 IMPACT

Ce guide de mise en route rapide résume les étapes de base nécessaires à l'installation, au démarrage et à la programmation du variateur de vitesse c.a. 1336 IMPACT. Les informations fournies NE PEUVENT EN AUCUN CAS REMPLACER celles du manuel utilisateur et ne peuvent être utilisées que par le personnel technique qualifié. Pour obtenir plus de détails sur les questions concernant d'autres applications et sur les précautions à prendre, consulter le manuel utilisateur du 1336 IMPACT (publication 1336 IMPACT-5.0).

## Câblage électrique – TB1

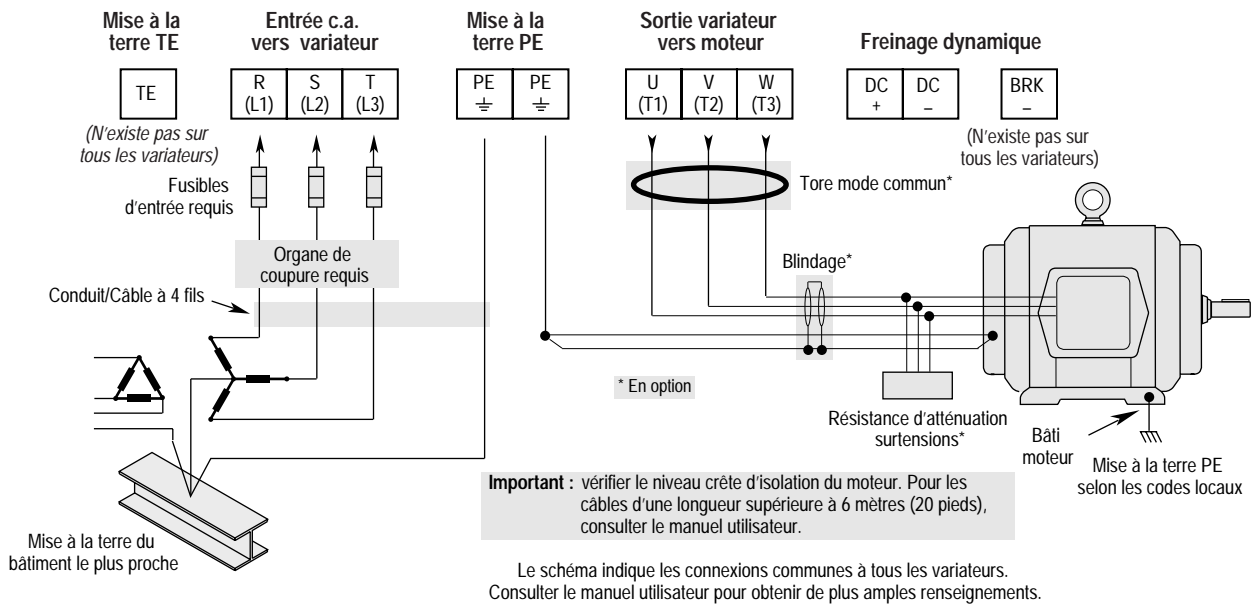

## Emplacement des cavaliers

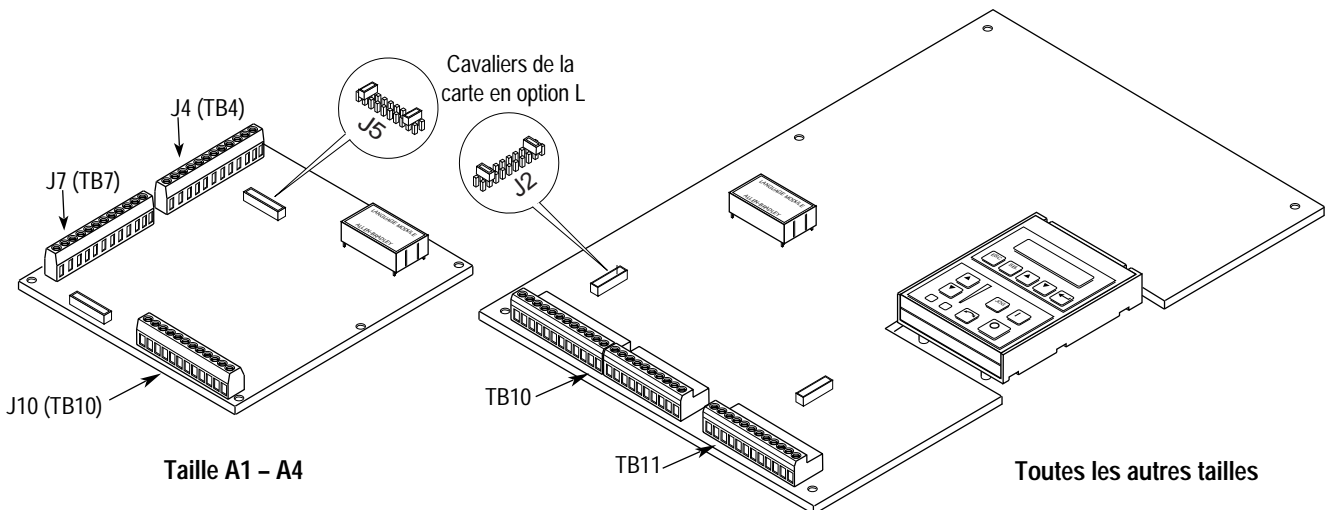

## Câblage Entrées/Sorties (E/S) – Tailles A

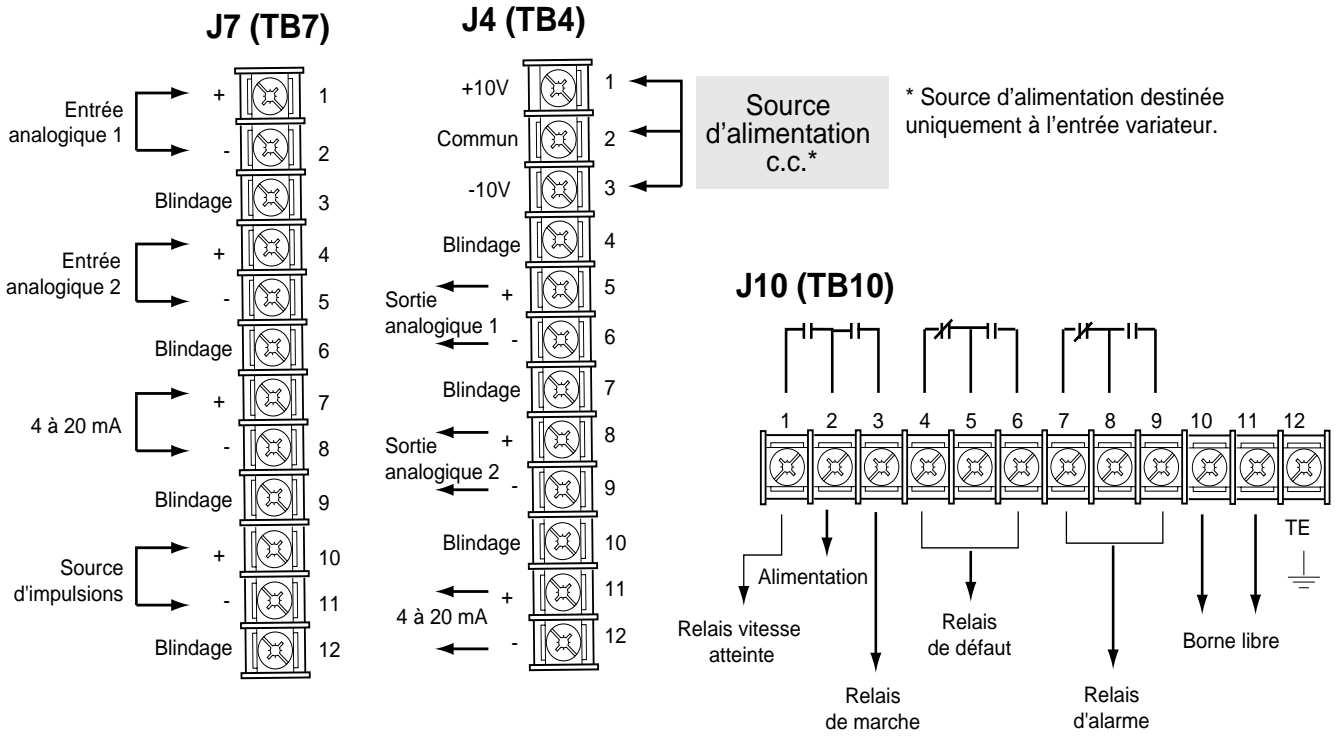

## Câblage E/S – Toutes les autres tailles

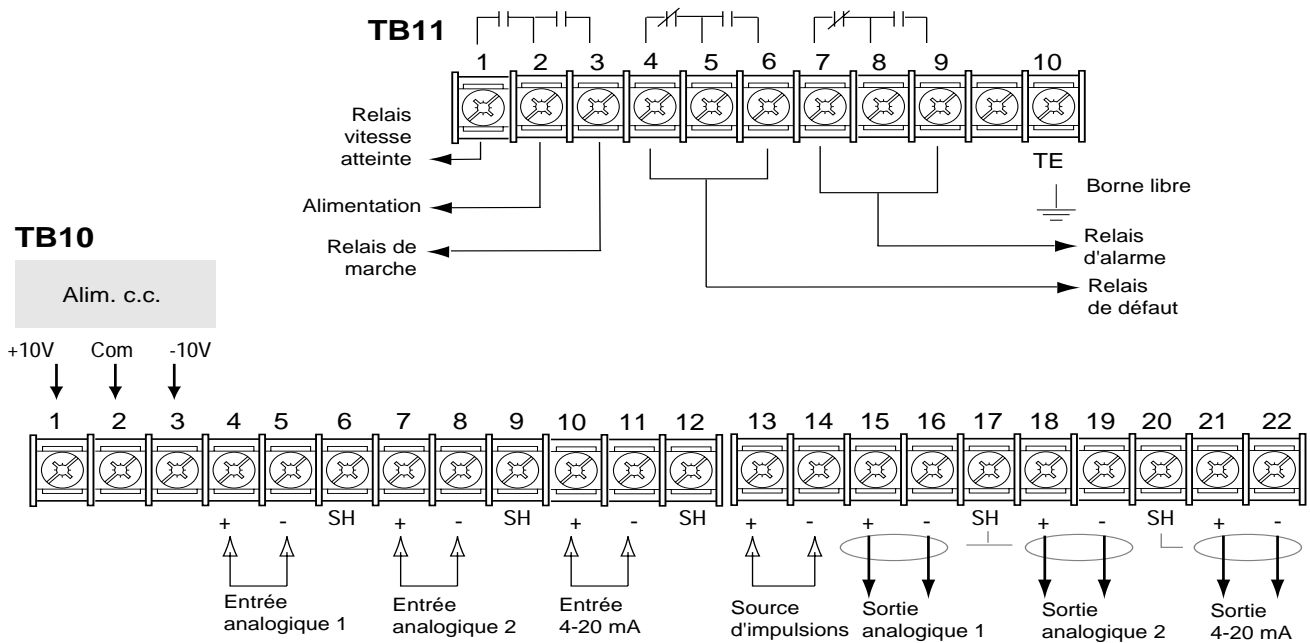

## Carte en option L

1	Etat	Arrêt/RAZ faute	Etat	Etat	Etat	Etat	Etat	Etat	Validation
2	Démarrage	Arrêt/RAZ faute	Arr./Av.	Impulsions	Faute ext.	Sél. Vit. 3	Sél. Vit. 2	Sél. Vit. 1	Validation
3	Démarrage	Arrêt/RAZ faute	Arr./Av.	Type Arrêt	Faute ext.	Sél. Vit. 3	Sél. Vit. 2	Sél. Vit. 1	Validation
4	Démarrage	Arrêt/RAZ faute	Arr./Av.	Accél. 2*/1	Faute ext.	Décél. 2*/1	Sél. Vit. 2	Sél. Vit. 1	Validation
5	Démarrage	Arrêt/RAZ faute	Arr./Av.	Augm. MOP	Faute ext.	Réduct. MOP	Sél. Vit. 2	Sél. Vit. 1	Validation
6	Démarrage	Arrêt/RAZ faute	Arr./Av.	Impulsions	Faute ext.	Local/À dist.	Sél. Vit. 2	Sél. Vit. 1	Validation
7	Démarrage	Arrêt/RAZ faute	Arrière	Avant	Faute ext.	Impulsions	Sél. Vit. 2	Sél. Vit. 1	Validation
8	Démarrage	Arrêt/RAZ faute	Arrière	Avant	Faute ext.	Sél. Vit. 3	Sél. Vit. 2	Sél. Vit. 1	Validation
9	Démarrage	Arrêt/RAZ faute	Augm. MOP	Réduct. MOP	Faute ext.	Sél. Vit. 3	Sél. Vit. 2	Sél. Vit. 1	Validation
10	Démarrage	Arrêt/RAZ faute	Arrière	Avant	Faute ext.	Augm. MOP	Réduct. MOP	Sél. Vit. 1	Validation
11	Démarrage	Arrêt/RAZ faute	Accél. 1	Accél. 2	Faute ext.	Décél. 1	Décél. 2	Sél. Vit. 1	Validation
12	Marche avant	Arrêt/RAZ faute	Marche arr.	Local/À dist.	Faute ext.	Sél. Vit. 3	Sél. Vit. 2	Sél. Vit. 1	Validation
13	Marche avant	Arrêt/RAZ faute	Marche arr.	Type Arrêt	Faute ext.	Sél. Vit. 3	Sél. Vit. 2	Sél. Vit. 1	Validation
14	Marche avant	Arrêt/RAZ faute	Marche arr.	Accél. 2*/1	Faute ext.	Décél. 2*/1	Sél. Vit. 2	Sél. Vit. 1	Validation
15	Marche avant	Arrêt/RAZ faute	Marche arr.	Augm. MOP	Faute ext.	Réduct. MOP	Sél. Vit. 2	Sél. Vit. 1	Validation
16	Marche avant	Arrêt/RAZ faute	Marche arr.	Local/À dist.	Faute ext.	Type Arrêt	Sél. Vit. 2	Sél. Vit. 1	Validation
17	Démarrage	Arrêt/RAZ faute	Arr./Av.	Valid. Ajust. P	Faute ext.	Invalid. Rampe	Sél. Vit. 2	Sél. Vit. 1	Validation
18	Démarrage	Arrêt/RAZ faute	Arr./Av.	Valid. flux	Faute ext.	Remise à zéro	Sél. Vit. 2	Sél. Vit. 1	Validation
19	Démarrage	Arrêt/RAZ faute	Vit./Couple 3	Vit./Couple 2	Faute ext.	Vit./Couple 1	Valid. Ajust. P	Sél. Vit. 1	Validation
20	Démarrage	Arrêt/RAZ faute	Vit./Couple 3	Vit./Couple 2	Faute ext.	Vit./Couple 1	Valid. flux	Sél. Vit. 1	Validation
21	Démarrage	Arrêt/RAZ faute	Arrière	Avant	Faute ext.	Invalid. Rampe	Remise à zéro	Sél. Vit. 1	Validation
22	Démarrage	Arrêt/RAZ faute	Vit./Couple 3	Vit./Couple 2	Faute ext.	Vit./Couple 1	Sél. Vit. 2	Sél. Vit. 1	Validation
23	Marche avant	Arrêt/RAZ faute	Marche arr.	Valid. Ajust. P	Faute ext.	Remise à zéro	Sél. Vit. 2	Sél. Vit. 1	Validation
24	Marche avant	Arrêt/RAZ faute	Marche arr.	Valid. flux	Faute ext.	Remise à zéro	Sél. Vit. 2	Sél. Vit. 1	Validation
25	Marche avant	Arrêt/RAZ faute	Marche arr.	Valid. Ajust. P	Faute ext.	Invalid. Rampe	Sél. Vit. 2	Sél. Vit. 1	Validation
26	Marche avant	Arrêt/RAZ faute	Marche arr.	Impulsions	Faute ext.	Sél. Vit. 3	Sél. Vit. 2	Sél. Vit. 1	Validation
27	Démarrage	Arrêt/RAZ faute	Arr./Av.	Augm. MOP	Faute ext.	Réduct. MOP	Sél. Vit. 2	Sél. Vit. 1	Validation
28	Démarrage	Arrêt/RAZ faute	Augm. MOP	Réduct. MOP	Faute ext.	Sél. Vit. 3	Sél. Vit. 2	Sél. Vit. 1	Validation
29	Démarrage	Arrêt/RAZ faute	Arrière	Avant	Faute ext.	Augm. MOP	Réduct. MOP	Sél. Vit. 1	Validation
30	Marche avant	Arrêt/RAZ faute	Marche arr.	MOP Incr	Faute ext.	Réduct. MOP	Sél. Vit. 2	Sél. Vit. 1	Validation

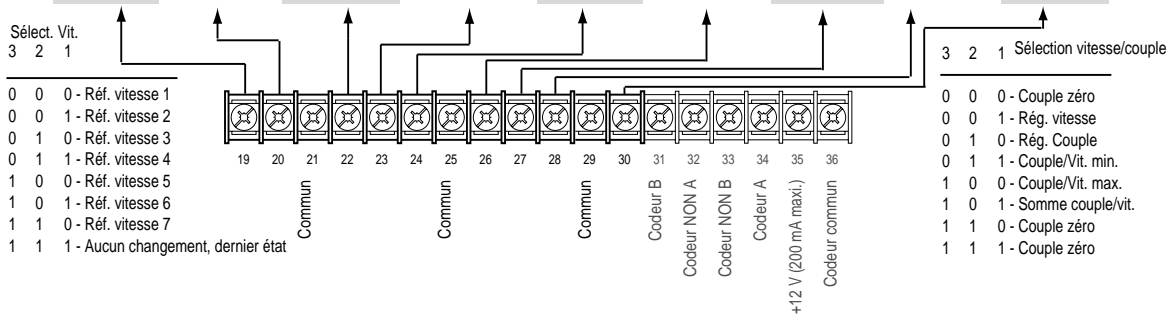

## Démarrage

La procédure de démarrage concerne seulement le réglage des valeurs les plus courantes ; elle s'effectue via le mode « Mise en route » [Startup] du 1336 IMPACT. Pour de plus amples renseignements, consulter le manuel utilisateur.

La procédure suivante a été élaborée et rédigée à l'intention des utilisateurs disposant d'un module interface opérateur (IHM). Les commandes externes et les signaux adéquats doivent être fournis aux utilisateurs sans IHM. Nous partons du principe que tous les paramètres ont conservé leur valeur par défaut.



**ATTENTION :** pour procéder aux étapes suivantes, le variateur doit être mis sous tension. Certaines tensions sont au potentiel de la ligne d'entrée. Afin d'éviter tout risque d'électrocution ou d'endommagement de votre équipement, seul le personnel qualifié peut effectuer les procédures suivantes. Il est recommandé de lire attentivement cette procédure avant de commencer. Si, lors du déroulement de la procédure, l'un des événements ne se produit pas, ne continuez pas. Couper l'alimentation électrique en déclenchant le sectionneur de dérivation et corriger le problème avant de continuer.



**ATTENTION :** afin d'éviter tout risque d'électrocution durant le câblage ou l'entretien du variateur de vitesse, vérifier que la tension des condensateurs de bus a été déchargée. Mesurer la tension du bus c.c. aux bornes + et - de TB1. Cette tension doit être égale à zéro.

1. Vérifier si l'alimentation secteur et l'alimentation de commande correspondent aux valeurs nominales spécifiées pour le variateur.
2. Si une option L a été installée, vérifier si les contacts Arrêt et Validation sont présents. Si cette option n'a pas été installée, vérifier si les cavaliers ont été installés sur les broches 3, 4, 17 et 18 sur J5 des variateurs de taille A, ou sur J2 pour les variateurs de taille B et ultérieurs. Consulter la section Emplacement des cavaliers.
3. En cas d'utilisation d'Entrées/Sorties standard, vérifier que les cavaliers ont été correctement câblés.
4. Si une option analogique a été installée, vérifier que les paramètres ont été configurés de façon appropriée (consulter le manuel utilisateur).



**ATTENTION :** durant chacune des étapes suivantes, le moteur peut se mettre à tourner. Afin d'éviter tout accident, rotation inappropriée et endommagement de l'équipement, lire attentivement les instructions de chaque étape et procéder avec prudence.

5. Mettre le variateur sous tension, appliquer les tensions de commande. L'affichage à cristaux liquides doit s'allumer et afficher l'état du variateur « Arrêté » [Stopped] et une fréquence de sortie de « +0,00 Hz ». Si le variateur détecte un problème, un message relatif au défaut s'affiche. Enregistrer l'information, déconnecter la source d'alimentation et corriger l'origine du problème avant de continuer.
6. A partir de l'écran d'affichage d'état, appuyer sur la touche Entrée (ou sur toute autre touche). Le message « Choisir mode » apparaît. Appuyer sur la touche « Incrément » ou « Décrément » jusqu'à ce que le message « Mise en route » [Startup] s'affiche. Appuyer sur « Entrée » [Enter].

**Important :** il est possible de répondre à toutes les questions par oui ou par non. Appuyer sur Entrée, puis sélectionner la valeur par défaut (« O » ou « N ») [Oui ou Non]. On peut modifier la sélection en appuyant sur la touche Incrément (ou Décrément). Appuyer sur Entrée pour effectuer une sélection. En choisissant « O », on accomplit les opérations de l'étape, et en choisissant « N » on passe directement à l'étape suivante. Le schéma ci-dessous illustre les différentes étapes.

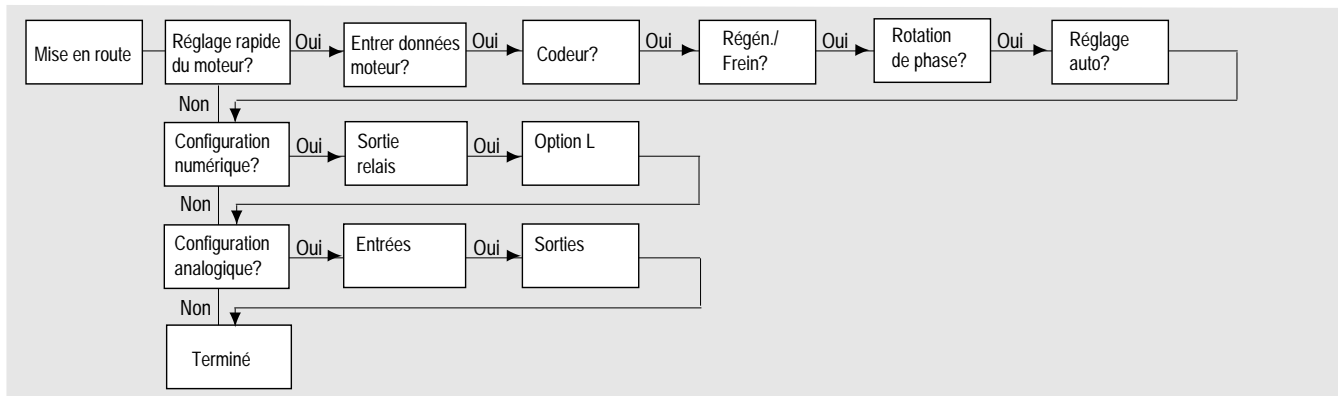

**Important :** il est recommandé de prendre connaissance des informations suivantes :

- On peut sortir du mode « Mise en route » [Startup] à tout moment en appuyant sur ESC [Échap.] jusqu'à ce que l'état soit affiché. Pour repasser en mode « Mise en route », sélectionner simplement « Réinit. séquence » [Reset Sequence] pour recommencer à partir du début. Choisir « Continuer » [Continue] permet de reprendre à l'endroit où l'on s'était arrêté.
  - L'exécution de la dernière action d'une étape fait passer automatiquement à l'étape suivante.
  - Appuyer sur SEL [sélectionner] pour activer la deuxième ligne de l'affichage. Ce processus doit être suivi pour toutes les valeurs.
  - Appuyer sur la touche Incrément (ou Décrément) pour régler une valeur (sauter cette étape si la valeur est correcte). Appuyer sur Entrée pour enregistrer la nouvelle valeur ou pour sauvegarder la valeur existante. Appuyer à nouveau sur Entrée, pour passer à l'étape suivante (paramètre).
7. Mettre hors/sous tension afin d'activer les changements. Cette action met un terme à la procédure de « Mise en route assistée » [Assisted Startup]. Selon l'application, il peut s'avérer nécessaire d'effectuer d'autres programmations de paramètres et/ou de « Mise en route évoluée » [Advanced Startup]. Consulter le manuel utilisateur pour obtenir plus de détails.

## Dimensions du variateur de vitesse

Afin de déterminer la taille du variateur, consulter l'illustration et le tableau suivants.

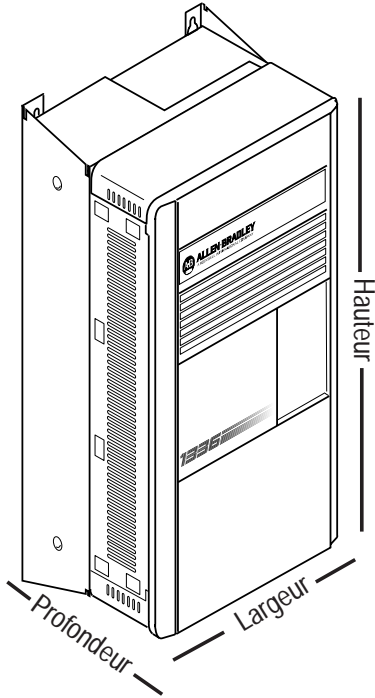

Taille	Largeur x Hauteur x Profondeur en millimètres (pouces)
A1	215,9 (8,50) x 290,0 (11,42) x 160,0 (6,30)
A2	215,9 (8,50) x 290,0 (11,42) x 180,5 (7,10)
A3	215,9 (8,50) x 290,0 (11,42) x 207,0 (8,15)
A4	260,0 (10,24) x 350,0 (13,78) x 212,0 (8,35)
B	276,4 (10,88) x 476,3 (18,75) x 225,0 (8,86)
C	301,8 (11,88) x 701,0 (27,60) x 225,0 (8,86)
D	381,5 (15,02) x 1240,0 (48,82) x 270,8 (10,66)
E-fermé	511,0 (20,12) x 1498,6 (59,00) x 477,5 (18,80)
E-ouvert	511,0 (20,12) x 1498,6 (59,00) x 372,6 (14,67)
F	762,0 (30,00) x 2286,0 (90,00) x 635,0 (25,00)
G	762,0 (30,00) x 2387,6 (94,0) x 635,0 (25,00)
H	1270,0 (50) x 2324,1 (91,50) <sup>①</sup> x 635,0 (25)

<sup>①</sup> Hauteur du ventilateur non comprise (635,0 (25,00)).

## Fonctionnement avec module interface opérateur (IHM)

La programmation ou l'affichage des paramètres s'effectue en mode Programme ou Affichage, comme indiqué ci-dessous.



1. Dans le menu Affichage, appuyer sur pour afficher « Choisir Mode » [Choose Mode].

2. Appuyer sur ou sur pour afficher « Programme » [Program] (ou « Affichage » [Display]).



3. Appuyer sur .

4. Appuyer sur ou sur jusqu'à ce que le fichier désiré s'affiche.



5. Appuyer sur .

6. Appuyer sur ou sur jusqu'à ce que le groupe désiré s'affiche.



7. Appuyer sur .

8. Appuyer sur ou sur pour faire défiler jusqu'au paramètre voulu.

## Structure de l'IHM

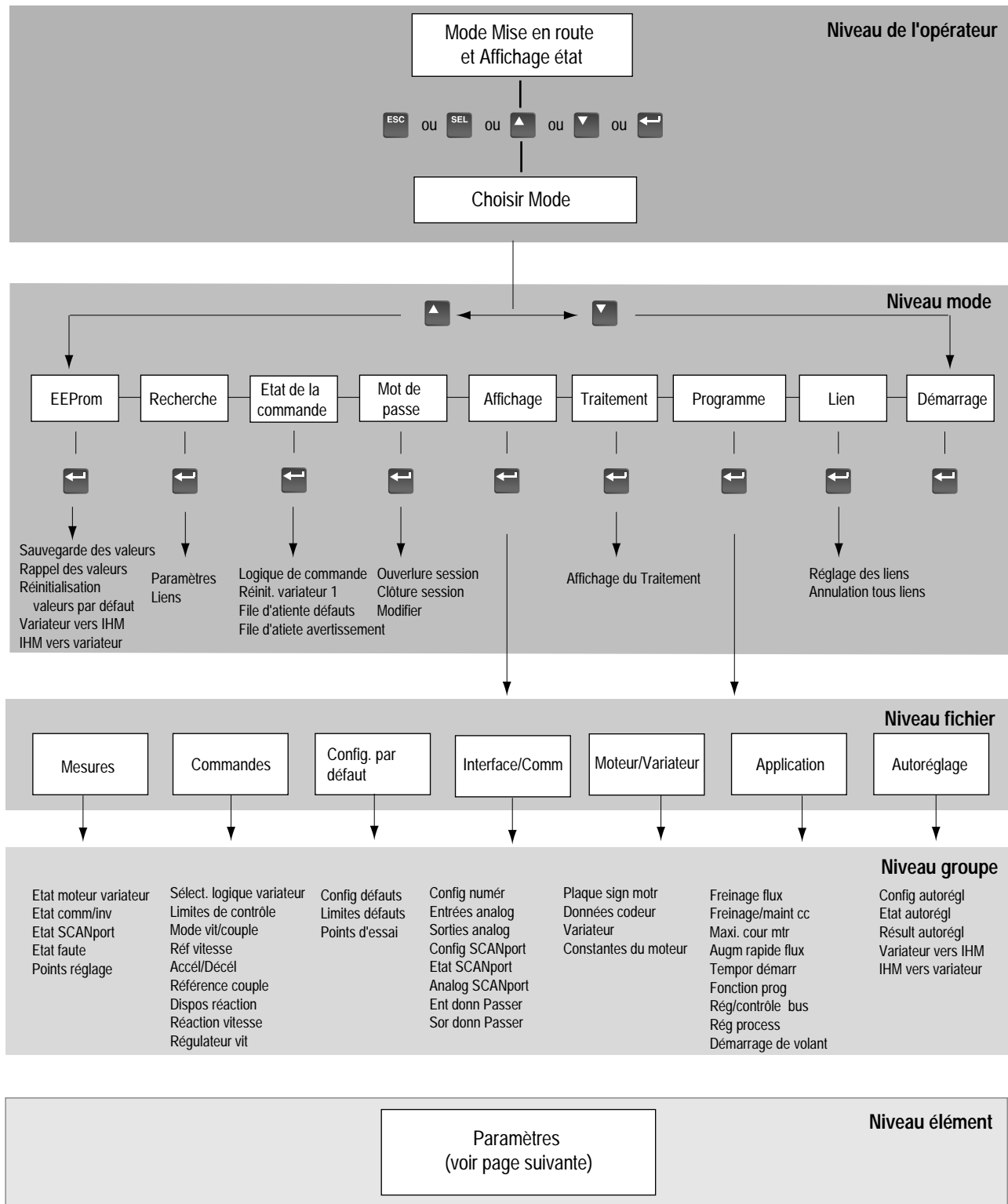

## Paramètres – Fichiers, groupes et éléments

Nom	N° réf.	Valeur min./max.	Nom	N° réf.	Valeur min./max.
<b>Mesures</b>			Lim int nég mot	73	Calc/0,0%
Etat moteur			Lim couple pos	74	0,0%/Calc
Vitesse moteur	81	-8 x BMS/+8 x BMS	Lim couple nég	75	Calc/0,0%
Fréquence moteur	89	-250,000/+250,000 Hz	Lim courant réac	76	-800,0%/0,0%
Intens moteur	83	0,0/6553,5 ampères	Lim taux chg int	77	Calc/200,0%
Tension moteur	85	0/+3000 volts	Intens max motr	195	0/1
% tension moteur	234	0/800%	Limite vit min	215	0,0/BMS tr/min
% couple moteur	86	-800,0/+800,0%	<b>Mode vitesse/couple</b>		
% flux moteur	88	12,5/100,0%	Sél mde vit/cple	68	0/5
% puiss moteur	90	-800,0/+800,0%	<b>Réf. vitesse</b>		
Pos Asser Enc basse	227	0/65535	Réf vitesse 1	29	-8x/+8xBMS tr/min
Pos Asser Enc haute	228	0/65535	Echelle vit 1	30	-3,9999/+3,9999
Réf couple int	229	-800/+800%	Réf vitesse 2	31	-8x/+8xBMS tr/min
Etat command/inv			Réf vitesse 3	32	-8x/+8xBMS tr/min
Tension bus cc	84	0/1000 volts	Réf vitesse 4	33	-8x/+8xBMS tr/min
Etat entrées log	14	Sélection de bit	Réf vitesse 5	34	-8x/+8xBMS tr/min
Etat command/inv	15	Sélection de bit	Réf vitesse 6	35	-8x/+8xBMS tr/min
Etat comm/inv 2	196	Sélection de bit	Réf vitesse 7	36	-8x/+8xBMS tr/min
Etat inv marche	16	Sélection de bit	Echelle vit 7	37	-3,9999/+3,9999
Etat vit command	82	-8 x BMS/+8 x BMS	Vit pas à pas 1	38	-8x/+8xBMS tr/min
Etat lim couple	87	Sélection de bit	Vit pas à pas 2	39	-8x/+8xBMS tr/min
Sortie régul Vit	225	-300,0/+300,0%	<b>Accél/décél</b>		
Erreur vitesse	226	-8 x BMS/+8 x BMS	Temps accél 1	42	0,0/6553,5 sec
Etat SCANport			Temps accél 2	43	0,0/6553,5 sec
Contr dir/réf	128	Sélection de bit	Temps décél 1	44	0,0/6553,5 sec
Contr dém/arrêt	129	Sélection de bit	Temps décél 2	45	0,0/6553,5 sec
Contr p à p 1/2	130	Sélection de bit	% courbe S	47	0,0/100,0%
Contr ramp/réarm	131	Sélection de bit	<b>Référence couple</b>		
Contr flux/régl	132	Sélection de bit	Réf couple 1	69	-800,0/+800,0%
Etat faute			% couple second	70	-200,00/+200,00%
Etat faute démarr	219	Sélection de bit	<b>Syst. réaction</b>		
Etat faute Ncfg	220	Sélection de bit	Type disp réac	64	1/3
Etat faute 1	221	Sélection de bit	Impuls/tr codeur	8	Calc/20000 ppr
Etat faute 2	222	Sélection de bit	<b>Réaction Vitesse</b>		
Etat avertissement 1	223	Sélection de bit	Réac vit proport	63	-32767/+32767
Etat avertissement 2	224	Sélection de bit	Sél filtre réac	65	0/4
Points réglage			Gain filtre réac	66	-5,00/+5,00
Données essai 1	92	-32768/+32767	Bde pas fil réac	67	0,2/900,0 rad/sec
Sél essai 1	93	0/65535	Fréq fil cpe-bde	185	5,0/135,0 Hz
Données essai 2	94	-32768/+32767	Q filtre cpe-bde	186	2/500
Sél essai 2	95	0/65535	<b>Régulateur vit</b>		
<b>Commandes</b>			Inertie totale	157	0,01 sec/655,00 sec
Sélect logique variateur			Bde pas vit inv	161	0,00 rad/sec/Calc
Options logiques	17	Sélections de bit	Bcle vitesse Ki	158	0,0/4095,9
Arrêt temporis	18	0,0/10,0 sec	Bcle vitesse Kp	159	0,0/200,0
Tol vitesse zéro	19	0,0 tr/min/8xBMS tr/min	Bcle vitesse Kf	160	0,500/1,000
Vit temp démarr	193	-0,1/+0,1 x BMS	Bde pas fil err	162	Calc/1500,0 rad/sec
Tempor démarr	194	0,0/10,0 sec	% réduction	46	0,0/25,5%
Limites contrôle			<b>Config par défaut</b>		
Limite vit ar	40	-6xBMS tr/min/0,0 tr/min	Config défauts		

Nom	N° réf.	Valeur min./max.	N° réf.	Valeur min./max.	N° réf.	Valeur min./max.	N° réf.	Valeur min./max.
Limite vit av	Fac éch sortie 2x BMS	0,0/1000	110	-1000/+1000	20	Sélection de bit		
	Valeur sortie mA	0/100	111	-32767/+32767				
Lim int pos mot	Dépl sortie %/s	0/10	112	-32000/+32000 mA	21	Sélection de bit		
Config défaut (suite)	Fac éch sortie mA	0/1000	113	-1000/+1000				
Sélect défaut 2	22	Sélection de bit		Val com 2 fil Sp	181	Sélection de bit		
Sélect avert 2	23	Sélection de bit		Msq val SCANport	124	Sélection de bit		
Limites défaut				Masque dir/réf	125	Sélection de bit		
Survit absolue	24	0,0 tr/min/BMS tr/min		Msq dém/p à p	126	Sélection de bit		
Temp bloc moteur	25	0,1/3276,7 sec		Msq réar/cnf déf	127	Sélection de bit		
% surch moteur	26	110,0/400,0%		Etat SCANport				
ss-tens secteur	27	10,0/90,0%		Contr dir/réf	128	Sélection de bit		
Points réglage				Contr dém/arrêt	129	Sélection de bit		
Données essai 1	92	-32768/+32768		Contr p à p 1/2	130	Sélection de bit		
Sél essai 1	93	0/65535		Contr ramp/réarm	131	Sélection de bit		
Données essai 2	94	-32768/+32767		Contr flux/régl	132	Sélection de bit		
Sél essai 2	95	0/65535		Analog SCANport				
<b>Interface/comm</b>				Sél en an 1 SP	133	1/16		
Config numér				Val ent an 1 SP	134	-32767/+32767		
Config relais 1	114	0/38		Ech ent an 1 SP	135	-1,000/+1,000		
Config relais 1	115	-800,0/+800,0%		Sél ent an 2 SP	136	1/16		
Config relais 2	187	0/36		Val ant an 2 SP	137	-32767/+32767		
Pt régl relais 2	188	-800,0/+800,0		Ech ent an 2 SP	138	-1,000/+1,000		
Config relais 3	189	0/36		Sort an SCANport	139	-32767/+32767		
Pt régl relais 3	190	-800,0/+800,0		Passerelle Entrée données				
Config relais 4	191	0/36		Entr données A1	140	-32767/+32767		
Pt régl relais 4	192	-800/+800,0%		Entr données A2	141	-32767/+32767		
Mode option L	116	1/25		Entr données B1	142	-32767/+32767		
Etat entr opt L	117	Sélection de bit		Entr données B2	143	-32767/+32767		
Incrémt pot man	118	0,0/BMS		Entr données C1	144	-32767/+32767		
Valeur pot man	119	0,0/BSMNA		Entr données C2	145	-32767/+32767		
Impuls par tr	120	500/2000		Entr données D1	146	-32767/+32767		
Fac éch ent imp	121	0,01/10,00		Entr données D2	147	-32767/+32767		
Dépl ent impuls	122	-BMS/+BMS		Passerelle Sortie données				
Valeur ent impul	123	0,0/+8xBMS		Sort données A1	148	-32767/+32767		
Entrées analog				Sort données A2	149	-32767/+32767		
Val ent analog 1	96	-32767/+32767		Sort données B1	150	-32767/+32767		
Dépl ent anal 1	97	-19,980/+19,980 volts		Sort données B2	151	-32767/+32767		
Fac éch ent an 1	98	-16,000/+16,000		Sort données C1	152	-32767/+32767		
B ps fil en an 1	182	0,0/200,0 rad/sec		Sort données C2	153	-32767/+32767		
Val ent analog 2	99	-32767/+32767		Sort données D1	154	-32767/+32767		
Dépl ent anal 2	100	-19,980/+19,980 volts		Sort données D2	155	-32767/+32767		
Fac éch ent an 2	101	-16,000/+16,000						
B ps fil en an 2	183	0,0/200,0 rad/sec						
Valeur entrée mA	102	-32767/+32767						
Dépl entrée mA	103	-32,000/+32,000 mA						
Fac éch entr mA	104	-16,00						
B pas fil ent mA	184	0,0/200,0 rad/sec						
Sorties analog								
Valeur sort an 1	105	-32767/+32767						
Dépl sort anal 1	106	-20,000/+20,000						
Fac éch sort an 1	107	-1,000/+1,000						
Valeur sort an 2	108	-32767/+32767						
Dépl sort anal 2	109	-19,980/+19,980 volts						

Nom	N° réf.	Valeur min./max.	Nom	N° réf.	Valeur min./max.
<b>Inverseur du moteur</b>			Sél fonction	212	0/27
Plaquette signalétique du moteur			Sort fonction 1	213	Diffère
Puiss nominale	2	0,2 hp/2000,0 hp	Sort fonction 2	214	0/65535
Vitesse nominale	3	1 tr/min/1500 tr/min	Entr fonction 9	232	-32767/+32767
Intens nominale	4	0,1 ampères/Calc	Entr fonction 10	233	-32767/+32767
Tension nominale	5	75 volts/575 volts	<b>Contrôle rég bus</b>		
Fréq nominale	6	1,0/250,0 Hz	Option Bus/Frein	13	Sélection de bit
Pôles moteur	7	2/2 pôles	<b>Réglage du processus</b>		
Facteur service	9	1,00/2,00	Sort ajust proc	48	-800,0/+800,0%
<b>Données de l'encodeur</b>			Réf ajust proc	49	-800,0/+800,0%
Impuls/tr codeur	8	Calc/2000 ppr	Réac ajust proc	50	-800,0/+800,0%
<b>Variateur</b>			Sélec ajust proc	51	Sélection de bit
Fréquence MLI	10	1000 Hz/à partir du variat.	Bde pas fil aj p	52	0,0/240,0 rad/sec
Intens inverseur	11	0,1 ampères/à.p.d.variat.	Charg ajust proc	53	-800,0/+800,0%
Tens inverseur	12	75/575 volts	Ajust proc Ki	54	0,000/16,000
<b>Constantes du moteur</b>			Ajust proc Kp	55	0,000/16,000
Résistnce stator	166	0,00/100,00%	Lim inf aj proc	58	-800,0/+800,0%
Inductance fuit	167	0,00/100,00%	Lim sup aj proc	59	-800,0/+800,0%
Intensité flux	168	0,00/75,00%	Gain sort aj pr	60	-8,000/+8,000
Gain glissement	169	0,0/400,0%	Régl vit ar max	61	-6 x /0,0 BMS tr/min
Pôles moteur	7	2/40 pôles	Régl vit av max	62	0,0 tr/min/+6xBMS tr/min
<b>Applications</b>			<b>Démarrage volant</b>		
Freinage du flux			Sél démarr volant	216	0/2
Option bus/frein	13	Sélection de bit	Vit démarr volant	217	P40/P41
Maintien de freinage cc			<b>Autoréglage</b>		
Option bus/frein	13	Sélection de bit	<b>Config autoréglage</b>		
Int freinage cc	79	0,0%/Calc	Sél autorégl/diag	173	Sélection de bit
Temps frein cc	80	0,0/6553,5 sec	Conf diag trans	172	Sélection de bit
Intensité moteur 400%			Couple autorégl	164	250%/100,0%
Intens max motr	195	0/1	Vitesse autorégl	165	0,3 x BMS/BMS
Augmentation rapide flux			<b>Etat autoréglage</b>		
Option bus/frein	13	Sélection de bit	Etat autoréglage	156	Sélection de bit
Niv flux rapide	78	100,0%/Calc	Diag invers 1	174	Sélection de bit
Temporisation démarrage			Diag invers 2	175	Sélection de bit
Vit temp démarr	193	-0,1 x / +0,1 x BMS	Erreurs autorégl	176	Sélection de bit
Tempor démarr	194	0,0/10,0 sec	<b>Résultat autoréglage</b>		
Fonction prog			Résistnce stator	166	0,00/100,00%
Entr fonction 1	198	Diffère	Inductance fuit	167	0,00/100,00%
Masq/val fonct 1	199	Diffère	Intensité flux	168	0,00/75,00%
Sél éval fonct 1	200	0/17	Gain glissement	169	0,0/400%
Entr fonction 2	201	Diffère	Inertie totale	157	0,0/655,00 sec
Masq/val fonct 2	202	Diffère	Bde pas vit inv	161	0,00/Calc rad/sec
Sél éval fonct 2	203	0/17			
Entr fonction 3	204	Diffère			
Masq/val fonct 3	205	Diffère			
Sél éval fonct 3	206	0/17			
Entr fonction 4	207	Diffère			
Entr fonction 5	208	Diffère			

<b>Nom</b>	<b>N° réf.</b>	<b>Valeur min./max.</b>	<b>Nom</b>	<b>N° réf.</b>	<b>Valeur min./max.</b>
Entr fonction 6	209	Diffère			
Entr fonction 7	210	Diffère			
Entr fonction 8	211	Sélection de bit			
Page intentionnellement laissée en blanc					





Allen-Bradley, a Rockwell Automation Business, has been helping its customers improve productivity and quality for more than 90 years. We design, manufacture and support a broad range of automation products worldwide. They include logic processors, power and motion control devices, operator interfaces, sensors and a variety of software. Rockwell is one of the world's leading technology companies.

### Worldwide representation.



Argentina • Australia • Austria • Bahrain • Belgium • Brazil • Bulgaria • Canada • Chile • China, PRC • Colombia • Costa Rica • Croatia • Cyprus • Czech Republic • Denmark • Ecuador • Egypt • El Salvador • Finland • France • Germany • Greece • Guatemala • Honduras • Hong Kong • Hungary • Iceland • India • Indonesia • Ireland • Israel • Italy • Jamaica • Japan • Jordan • Korea • Kuwait • Lebanon • Malaysia • Mexico • Netherlands • New Zealand • Norway • Pakistan • Peru • Philippines • Poland • Portugal • Puerto Rico • Qatar • Romania • Russia-CIS • Saudi Arabia • Singapore • Slovakia • Slovenia • South Africa, Republic • Spain • Sweden • Switzerland • Taiwan • Thailand • Turkey • United Arab Emirates • United Kingdom • United States • Uruguay • Venezuela • Yugoslavia

Allen-Bradley Headquarters, 1201 South Second Street, Milwaukee, WI 53204 USA, Tel: (1) 414 382-2000 Fax: (1) 414 382-4444

# 1336 IMPACT Guida all'avviamento rapido

Questa Guida all'avviamento rapido riassume le operazioni di base necessarie per installare, avviare e programmare l'inverter CA a frequenza variabile 1336 IMPACT. Le informazioni qui contenute NON sostituiscono il Manuale dell'utente e sono rivolte esclusivamente al personale qualificato per la manutenzione dell'inverter. Per informazioni dettagliate su altre considerazioni per l'uso dell'inverter e le relative precauzioni, consultare il Manuale dell'utente di 1336 IMPACT (pubblicazione 1336 IMPACT-5.0).

## Cablaggio – TB1

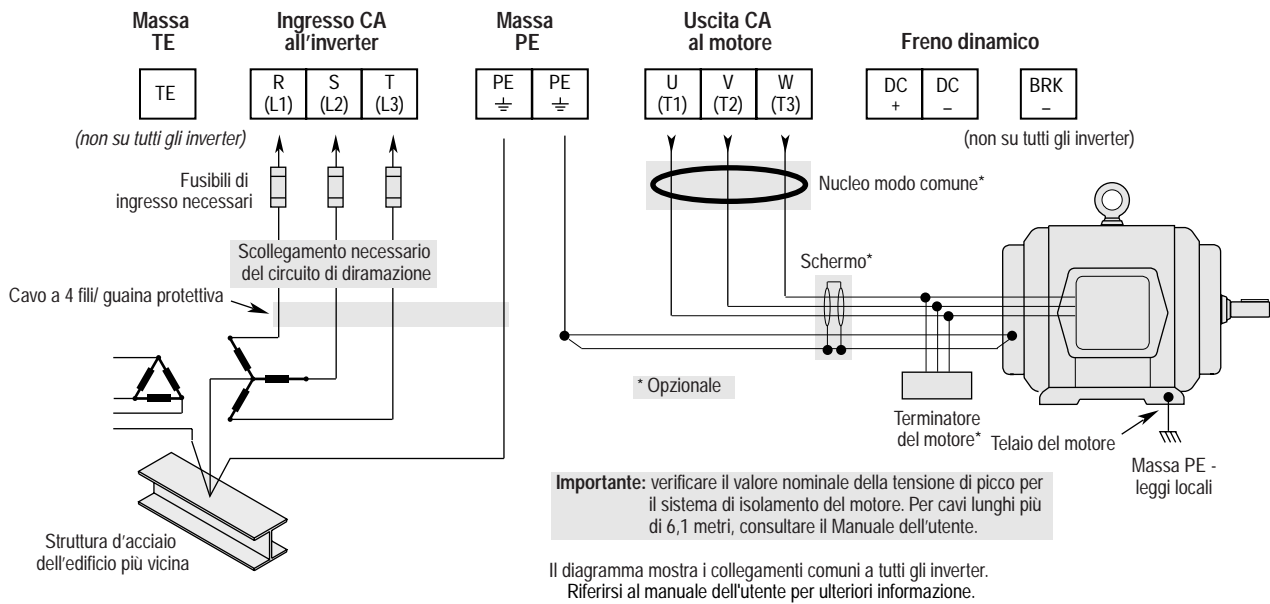

## Posizione dei ponticelli

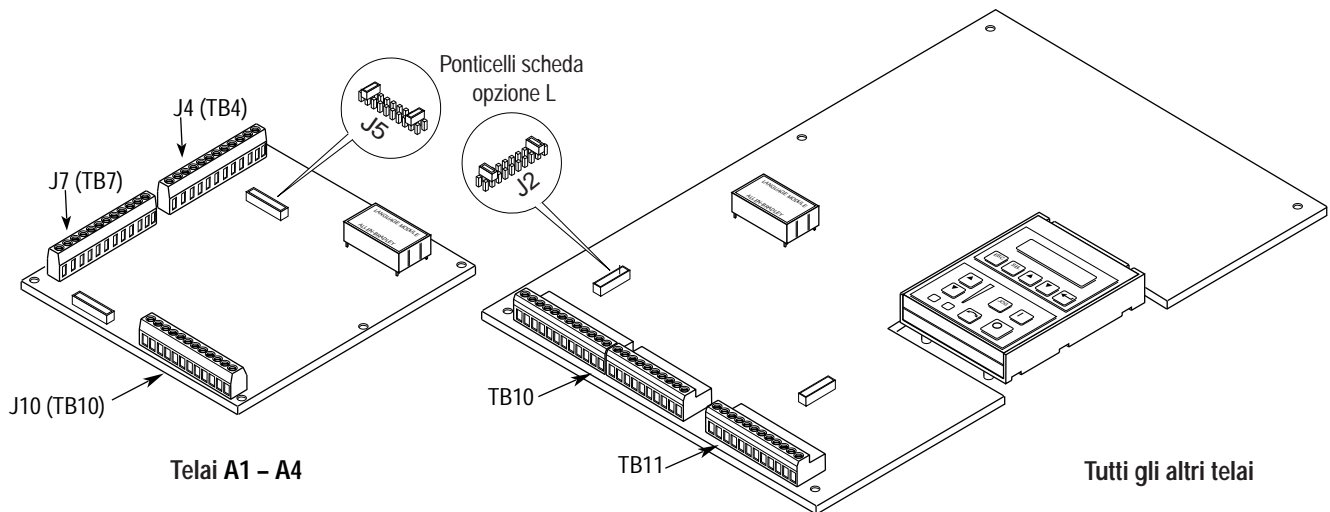

## Cablaggio I/O – Telai A

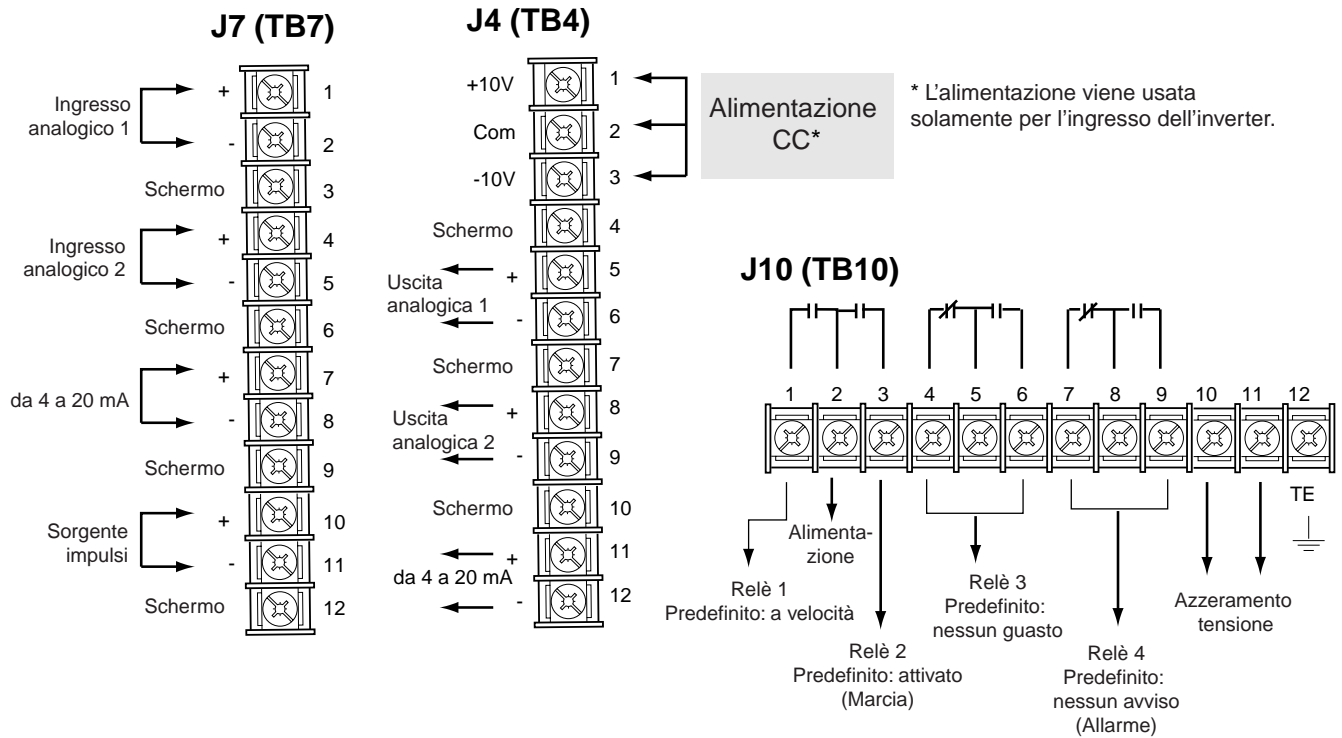

## Cablaggio I/O – Tutti gli altri telai

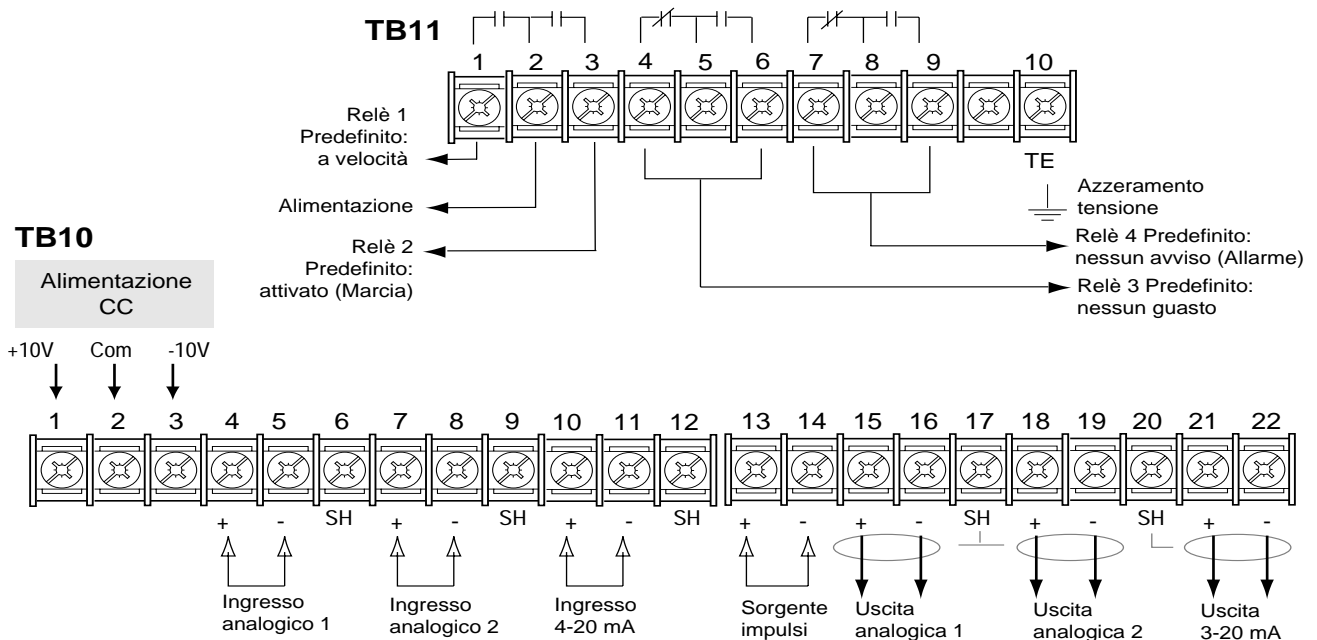

## Scheda opzione L

1	Stato	Stop/Elimina Guasto	Stato	Stato	Stato	Stato	Stato	Stato	Attiva
2	Avvio	Stop/Elimina Guasto	Inversa/Avanti	Impulsi	Gsto Est	Sel vel 3	Sel vel 2	Sel vel 1	Attiva
3	Avvio	Stop/Elimina Guasto	Inversa/Avanti	Tipo arresto	Gsto Est	Sel vel 3	Sel vel 2	Sel vel 1	Attiva
4	Avvio	Stop/Elimina Guasto	Inversa/Avanti	Accel 2*/1	Gsto Est	Decel 2*/1	Sel vel 2	Sel vel 1	Attiva
5	Avvio	Stop/Elimina Guasto	Inversa/Avanti	Incr. MOP	Gsto Est	Decr. MOP	Sel vel 2	Sel vel 1	Attiva
6	Avvio	Stop/Elimina Guasto	Inversa/Avanti	Impulsi	Gsto Est	Loc/Rem	Sel vel 2	Sel vel 1	Attiva
7	Avvio	Stop/Elimina Guasto	Inversa	Avanti	Gsto Est	Impulsi	Sel vel 2	Sel vel 1	Attiva
8	Avvio	Stop/Elimina Guasto	Inversa	Avanti	Gsto Est	Sel vel 3	Sel vel 2	Sel vel 1	Attiva
9	Avvio	Stop/Elimina Guasto	Incr. MOP	Decr. MOP	Gsto Est	Sel vel 3	Sel vel 2	Sel vel 1	Attiva
10	Avvio	Stop/Elimina Guasto	Inversa	Avanti	Gsto Est	Incr. MOP	Decr. MOP	Sel vel 1	Attiva
11	Avvio	Stop/Elimina Guasto	Accel 1	Accel 2	Gsto Est	Decel 1	Decel 2	Sel vel 1	Attiva
12	Marcia/Avanti	Stop/Elimina Guasto	Marcia inversa	Loc/Rem	Gsto Est	Sel vel 3	Sel vel 2	Sel vel 1	Attiva
13	Marcia/Avanti	Stop/Elimina Guasto	Marcia inversa	Tipo arresto	Gsto Est	Sel vel 3	Sel vel 2	Sel vel 1	Attiva
14	Marcia/Avanti	Stop/Elimina Guasto	Marcia inversa	Accel 2*/1	Gsto Est	Decel 2*/1	Sel vel 2	Sel vel 1	Attiva
15	Marcia/Avanti	Stop/Elimina Guasto	Marcia inversa	Incr. MOP	Gsto Est	Decr. MOP	Sel vel 2	Sel vel 1	Attiva
16	Marcia/Avanti	Stop/Elimina Guasto	Marcia inversa	Loc/Rem	Gsto Est	Tipo arresto	Sel vel 2	Sel vel 1	Attiva
17	Avvio	Stop/Elimina Guasto	Inversa/Avanti	Attiva PTrim	Gsto Est	Dis Rampa	Sel vel 2	Sel vel 1	Attiva
18	Avvio	Stop/Elimina Guasto	Inversa/Avanti	Attiva Flusso	Gsto Est	Azzera	Sel vel 2	Sel vel 1	Attiva
19	Avvio	Stop/Elimina Guasto	Vel/Coppia 3	Vel/Coppia 2	Gsto Est	Vel/Coppia 1	Attiva PTrim	Sel vel 1	Attiva
20	Avvio	Stop/Elimina Guasto	Vel/Coppia 3	Vel/Coppia 2	Gsto Est	Vel/Coppia 1	Attiva Flusso	Sel vel 1	Attiva
21	Avvio	Stop/Elimina Guasto	Inversa	Avanti	Gsto Est	Dis Rampa	Azzera	Sel vel 1	Attiva
22	Avvio	Stop/Elimina Guasto	Vel/Coppia 3	Vel/Coppia 2	Gsto Est	Vel/Coppia 1	Sel vel 2	Sel vel 1	Attiva
23	Marcia/Avanti	Stop/Elimina Guasto	Marcia inversa	Attiva PTrim	Gsto Est	Azzera	Sel vel 2	Sel vel 1	Attiva
24	Marcia/Avanti	Stop/Elimina Guasto	Marcia inversa	Attiva Flusso	Gsto Est	Azzera	Sel vel 2	Sel vel 1	Attiva
25	Marcia/Avanti	Stop/Elimina Guasto	Marcia inversa	Attiva PTrim	Gsto Est	Dis Rampa	Sel vel 2	Sel vel 1	Attiva
26	Marcia/Avanti	Stop/Elimina Guasto	Marcia inversa	Impulsi	Gsto Est	Sel vel 3	Sel vel 2	Sel vel 1	Attiva
27	Avvio	Stop/Elimina Guasto	Inversa/Avanti	Incr. MOP	Gsto Est	Decr. MOP	Sel vel 2	Sel vel 1	Attiva
28	Avvio	Stop/Elimina Guasto	Incr. MOP	Decr. MOP	Gsto Est	Sel vel 3	Sel vel 2	Sel vel 1	Attiva
29	Avvio	Stop/Elimina Guasto	Inversa	Avanti	Gsto Est	Incr. MOP	Decr. MOP	Sel vel 1	Attiva
30	Marcia/Avanti	Stop/Elimina Guasto	Marcia inversa	Incr. MOP	Gsto Est	Decr. MOP	Sel vel 2	Sel vel 1	Attiva

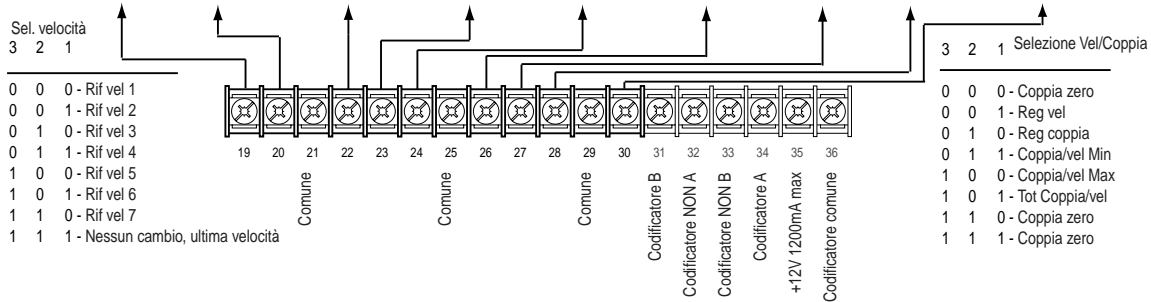

## Avviamento

Questa procedura di avviamento illustra solamente i valori regolati più di frequente usando la modalità "Avviamento" dell'inverter 1336 IMPACT. Per informazioni dettagliate, consultare il Manuale dell'utente.

La procedura che segue è concepita per gli utenti che hanno installato il Modulo di interfaccia operatore (HIM). Gli utenti senza HIM dovranno fornire i rispettivi comandi e segnali esterni. Si presume inoltre che tutti i parametri siano sulle impostazioni predefinite di fabbrica.



**ATTENZIONE:** per eseguire le seguenti operazioni è necessario che l'inverter sia acceso. Alcune delle tensioni presenti sono al potenziale della linea in entrata. Per evitare il rischio di scossa elettrica o danni all'unità, la procedura seguente deve essere eseguita solamente da personale qualificato per la manutenzione dell'inverter. Leggere e capire l'intera procedura prima di iniziare. Se un evento non si verifica durante l'esecuzione della procedura, **NON CONTINUARE**. Interrompere l'alimentazione dell'inverter aprendo il dispositivo di scollegamento del circuito di diramazione e correggere il problema prima di continuare.



**ATTENZIONE:** per evitare il rischio di scossa elettrica mentre si effettuano i collegamenti dei fili elettrici o durante la manutenzione dell'inverter, accertarsi che sia stata scaricata la tensione sui condensatori del bus. Misurare la tensione CC del bus e i terminali + e - di TB1. La tensione deve essere zero

1. Verificare che la potenza CA di rete e la potenza dei controlli coincidano con la potenza nominale dell'inverter.
2. Se è installata l'opzione L, verificare che siano presenti gli ingressi dei dispositivi di blocco Arresto e Attiva. Se questa opzione non è installata, controllare che i ponticelli siano installati sui piedini 3 e 4, 17 e 18 di J5 sugli inverter Telaio A, oppure J2 sugli inverter Telaio B e superiore. Vedere Posizione dei ponticelli.
3. Se viene usato un I/O standard, verificare che i ponticelli siano collegati correttamente.
4. Se è installata l'Opzione Analogica, verificare che i parametri siano correttamente configurati (vedere il Manuale dell'utente).



**ATTENZIONE:** in tutte le operazioni seguenti, può verificarsi la rotazione del motore. Per proteggersi da potenziali infortuni, rotazione scorretta e possibili danni all'unità, leggere attentamente ogni operazione ed eseguirla con cautela.

5. Applicare la potenza CA e le tensioni dei controlli all'inverter. Il display a cristalli liquidi dovrebbe accendersi e visualizzare la condizione di "Arrestato" dell'inverter ed una frequenza di uscita di "+0,00 Hz". Se l'inverter rileva un guasto, il display mostra informazioni relative al guasto. Prendere nota di tali informazioni, rimuovere la potenza e, prima di continuare, correggere il guasto.
6. Dallo schermo della condizione dell'inverter, premere il tasto Invio (o un tasto qualsiasi). Viene visualizzato "Scegli modalità". Premere il tasto Incrementa (o Decrementa) fino a quando appare "Avvio". Premere Invio.

**Importante:** a tutte le domande si risponde Sì o No. Premendo Invio viene selezionata la risposta predefinita ("S" o "N"). Premendo il tasto Incrementa (o Decrementa) la selezione viene cambiata. Premere Invio per selezionare. Selezionando "S" si può procedere con l'operazione; selezionando "N" si passa all'operazione successiva. La figura qui sotto mostra la sequenza delle operazioni.

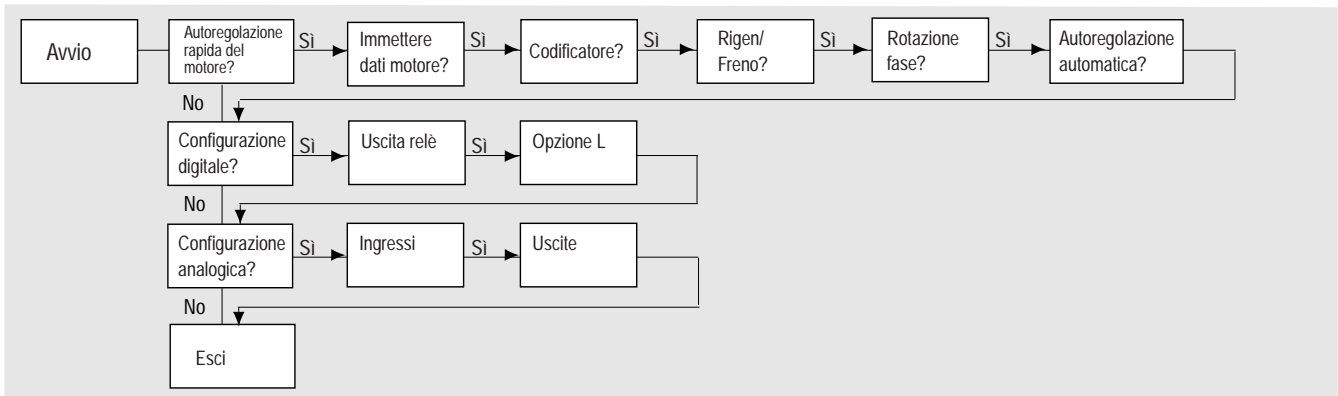

**Importante:** notare quanto segue:

- È possibile uscire dalla modalità "Avvio" in qualsiasi momento premendo ESC fino a quando appare Display Stato. Se si desidera passare di nuovo alla modalità "Avvio", selezionare "Azzerare sequenza" per ricominciare dall'inizio. Selezionando "Continua" è possibile riprendere l'operazione dal punto in cui è stata interrotta.
  - Il completamento dell'ultima azione di qualsiasi operazione produce il passaggio all'operazione successiva.
  - Premendo SEL viene attivata la riga 2 del display. Questo deve essere fatto per tutti i valori.
  - Premere il tasto Incrementa (o Decrementa) per regolare un valore (saltare se il valore è quello corretto). Premere Invio per memorizzare il nuovo valore o per conservare il valore esistente. Premendo di nuovo Invio si passa all'operazione successiva (parametro).
7. Per rendere efficaci i cambiamenti, togliere e rinviare alimentazione. Con ciò si conclude la procedura "Avviamento guidato". A seconda della propria applicazione, può darsi sia necessaria una ulteriore programmazione di parametri e/o la procedura "Avviamento avanzato". Per informazioni, vedere il Manuale dell'utente.

## Dimensioni dell'inverter

Per determinare la dimensione del proprio inverter, fare riferimento alla figura e alla tabella seguenti.

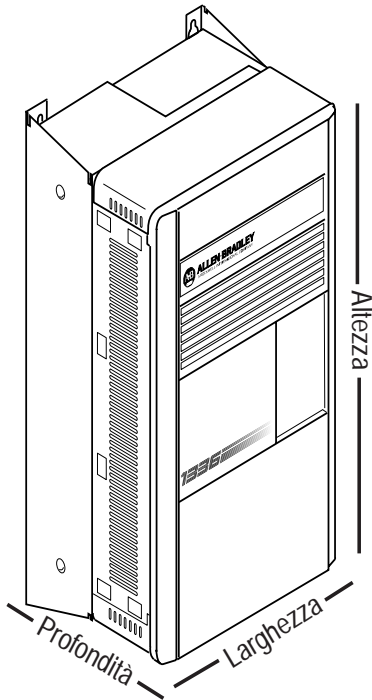

Telaio	Larghezza x Altezza x Profondità Millimetri
A1	215,9 x 290,0 x 160,0
A2	215,9 x 290,0 x 180,5
A3	215,9 x 290,0 x 207,0
A4	260,0 x 350,0 x 212,0
B	276,4 x 476,3 x 225,0
C	301,8 x 701,0 x 225,0
D	381,5 x 1240,0 x 270,8
E-Con custodia	511,0 x 1498,6 x 477,5
E-Aperto	511,0 x 1498,6 x 372,6
F	762,0 x 2286,0 x 635,0
G	762,0 x 2387,6 x 635,0
H	1270,0 x 2324,1 <sup>①</sup> x 635,0

<sup>①</sup> L'altezza del ventilatore (635 mm) non è inclusa.

## Funzionamento del Modulo di Interfaccia Operatore (HIM)

La programmazione o la visualizzazione dei parametri è possibile usando le modalità Programma o Visualizzazione, indicate qui sotto.



1. Da Display Stato, premere per visualizzare "Scegli modalità".



2. Premere o per visualizzare "Programma" (o "Display").

3. Premere .



4. Premere o fino a quando appare il file desiderato.

5. Premere .

6. Premere o fino a quando appare il gruppo desiderato.



7. Premere .

8. Premere o o per scorrere al parametro desiderato.

## Struttura HIM

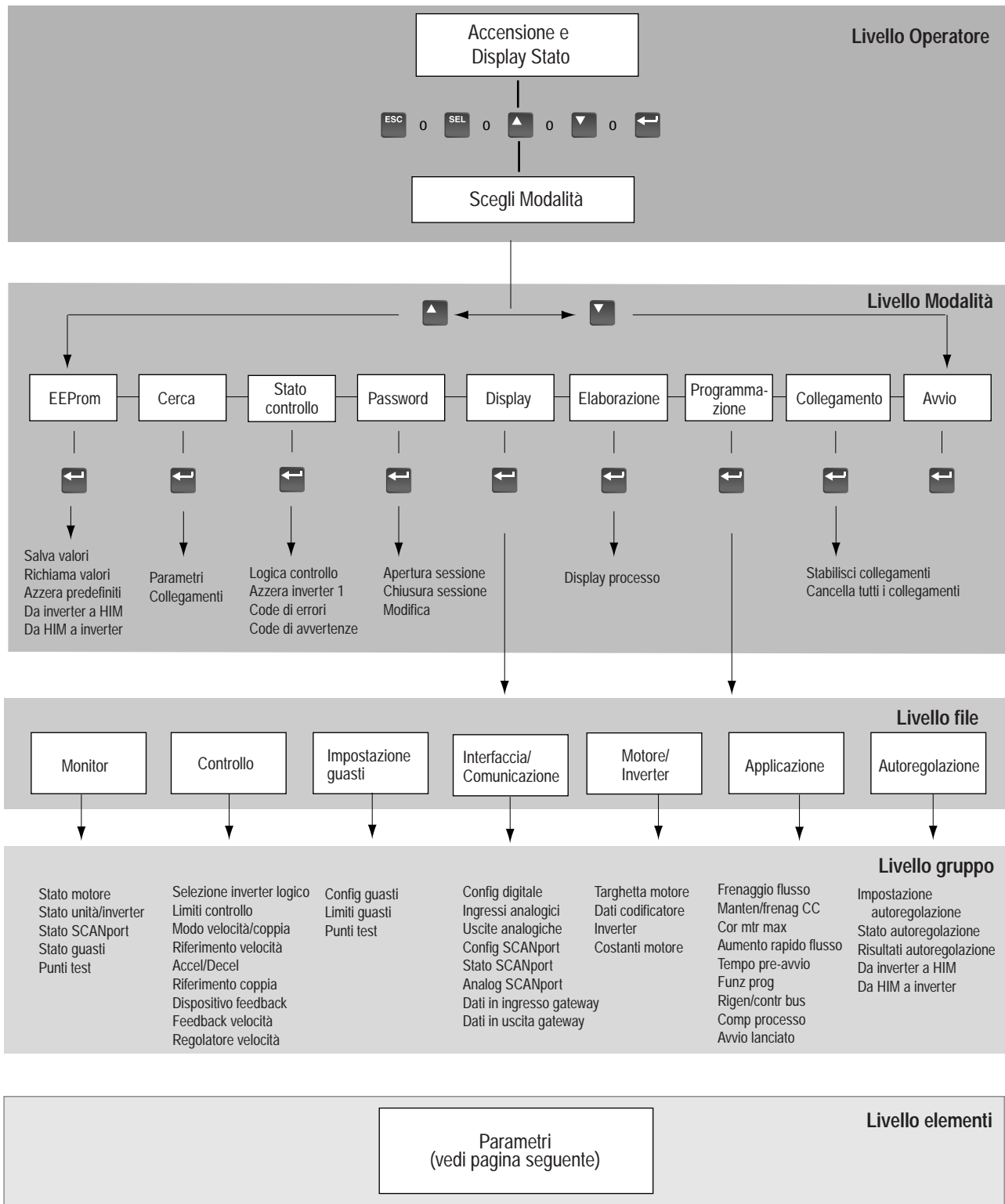

## Parametri – File, Gruppi ed Elementi

Nome	N.	Val. Min/Max	Nome	N.	Val. Min/Max
<b>Monitor</b>			Lim neg cor mtr	73	Calc/0,0%
Stato del monitor			Lim posit coppia	74	0,0%/Calc
Velocità motore	81	-8 x BMS/+8 x BMS	Lim negat coppia	75	Calc/0,0%
Frequenza motore	89	-250,000/+250,000 Hz	Lim alim rigen	76	-800,0%/0,0%
Corrente motore	83	0,0/6553,5 amps	Lim tasso corren	77	Calc/200,0%
Tensione motore	85	0/+3000 volts	Corrente max mtr	195	0/1
% tensione motore	234	0/800%	Limite vel. min	215	0,0/BMS giri/min.
% coppia motore	86	-800,0/+800,0%	<b>Modo velocità/coppia</b>		
% flusso motore	88	12,5/100,0%	Sel modo vel/cop	68	0/5
% alim motore	90	-800,0/+800,0%	<b>Riferimento velocità</b>		
Rit Bs Pos Cod	227	0/65535	Rif. vel. 1	29	-8x/+8xBMS giri/min.
Rit Alto Pos Cod	228	0/65535	Scala vel. 1	30	-3,9999/+3,9999
Rif Int Coppia	229	-800/+800%	Rif. vel. 2	31	-8x/+8xBMS giri/min.
Stato unità/inverter			Rif. vel. 3	32	-8x/+8xBMS giri/min.
Tensione bus CC	84	0/1000 volts	Rif. vel. 4	33	-8x/+8xBMS giri/min.
Stat imp logica	14	Selezione bit	Rif. vel. 5	34	-8x/+8xBMS giri/min.
Stat unità/inverter	15	Selezione bit	Rif. vel. 6	35	-8x/+8xBMS giri/min.
Stat unit/inv 2	196	Selezione bit	Rif. vel. 7	36	-8x/+8xBMS giri/min.
Causa non funz	16	Selezione bit	Scala vel. 7	37	-3,9999/+3,9999
Stato vel cmd	82	-8 x BMS/+8 x BMS	Vel. jog 1	38	-8x/+8xBMS giri/min.
Stat lim coppia	87	Selezione bit	Vel. jog 2	39	-8x/+8xBMS giri/min.
Usc Regol Veloc	225	-300,0/+300,0%	<b>Accel/Decel</b>		
Errore Velocità	226	-8 x BMS/+8 x BMS	Tempo accel. 1	42	0,0/6553,5 sec
Stato SCANport			Tempo accel. 2	43	0,0/6553,5 sec
Prop dir/rif	128	Selezione bit	Tempo decel. 1	44	0,0/6553,5 sec
Prop avv/arresto	129	Selezione bit	Tempo decel. 2	45	0,0/6553,5 sec
Prop jog1/jog2	130	Selezione bit	% curva S	47	0,0/100,0%
Pr ramp/eli gst	131	Selezione bit	<b>Riferimento coppia</b>		
Prop flusso/comp	132	Selezione bit	Rif. coppia 1	69	-800,0/+800,0%
Stato guasti			% coppia slave	70	-200,00/+200,00%
St Gua Acc.	219	Selezione bit	<b>Dispositivo feedback</b>		
St Gua Non Conf	220	Selezione bit	Tipo disp fdbk	64	1/3
St Guasto 1	221	Selezione bit	Codificatore PPR	8	Calc/20000 ppr
St Guasto 2	222	Selezione bit	<b>Feedback velocità</b>		
Avvert Guasto 1	223	Selezione bit	Fdb vel in scala	63	-32767/+32767
Avvert Guasto 2	224	Selezione bit	Sel filtro fdbk	65	0/4
Punti di test			Guad filtr fdbk	66	-5,00/+5,00
Dati test 1	92	-32768/+32767	Banda filtr fdbk	67	0,2/900,0 rad/sec
Test 1	93	0/65535	Frq filtro intagl	185	5,0/135,0 Hz
Dati test 2	94	-32768/+32767	Q filtro intaglio	186	2/500
Test 2	95	0/65535	<b>Regolatore velocità</b>		
<b>Controllo</b>			Inerzia totale	157	0,01 sec/655,00 sec
Selezione logica unità			Banda per vel	161	0,00 rad/sec/Calc
Opzioni logica	17	Selezione bit	Ciclo vel. Ki	158	0,0/4095,9
Tipo pre-arresto	18	0,0/10,0 sec	Ciclo vel. Kp	159	0,0/200,0
Toll vel. zero	19	0,0 giri/min./8xBMS giri/min.	Ciclo vel. Kf	160	0,500/1,000
Vel pre-avvio	193	-0,1/+0,1 x BMS	Banda filtro err	162	Calc/1500,0 rad/sec
Tpo pre-avvio	194	0,0/10,0 sec	Percentuale scarto giri	46	0,0/25,5%
Limiti controllo			<b>Impostazione guasti</b>		
Vel. max ind.	40	-6xBMS giri/min./0,0 giri/min.	Config guasti		

Nome	Nome	Val. Min/Max	N.	Val. Min/Max	Nome	Val. Min/Max	N.	Val. Min/Max
Vel. max av.	Scala An In 1	0,0/20,0	110	-1,000/+1,000	20	Selezione bit		
	Valore Input mA	0,0/10,0	111	-32767/+32767				
Lim pos cor mtr	Scarto Output mA	0,0/32,0	112	-32,000/+32,000 mA	21	Selezione bit		
Config guasti (continua)	Scala Output mA	0,0/10,0	113	-1000/+1000				
Errore 2	22	Selezione bit		Fili SP 2	181	Selezione bit		
Avvertimento 2	23	Selezione bit		Maschera abil SP	124	Selezione bit		
Limiti guasti				Maschera dir/rif	125	Selezione bit		
Sovrael. Assol	24	0,0 giri/min./BMS giri/min.		Masch avvio/jog	126	Selezione bit		
Tempo pre-stallo	25	0,1/3276,7 sec		Msch eli gst/res	127	Selezione bit		
% Sovrac motore	26	110,0/400,0%		Stato Scanport				
Sottovoltaggio	27	10,0/90,0%		Prop dir/rif	128	Selezione bit		
Punti di test				Prop avv/arresto	129	Selezione bit		
Dati test 1	92	-32768/+32768		Jog1/Jog2	130	Selezione bit		
Test 1	93	0/65535		Pr ramp/eli gst	131	Selezione bit		
Dati test 2	94	-32768/+32767		Prop flusso/comp	132	Selezione bit		
Test 2	95	0/65535		Analog SCANport				
<b>Interf./Comun.</b>				SP An In 1	133	1/16		
Config digitale				Val SP An In 1	134	-32767/+32767		
Config rel	114	0/38		Scala SP An In 1	135	-1,000/+1,000		
Config rel 1	115	-800,0/+800,0%		SP An In 2	136	1/16		
Config rel 2	187	0/36		Val SP An In 2	137	-32767/+32767		
Soglia rel 2	188	-800,0/+800,0		Scala SP An In 2	138	-1,000/+1,000		
Config rel 3	189	0/36		Output anal. SP	139	-32767/+32767		
Soglia rel 3	190	-800,0/+800,0		Inp dati gateway				
Config rel 4	191	0/36		Dati Input A1	140	-32767/+32767		
Soglia rel 4	192	-800/+800,0%		Dati Input A2	141	-32767/+32767		
Modo opzione L	116	1/25		Dati Input B1	142	-32767/+32767		
Stat Input Opz L	117	Selezione bit		Dati Input B2	143	-32767/+32767		
Incremento MOP	118	0,0/BMS		Dati Input C1	144	-32767/+32767		
Valore MOP	119	0,0/BSMNA		Dati Input C2	145	-32767/+32767		
Impulsi per giro	120	500/2000		Dati Input D1	146	-32767/+32767		
Scala impulsi	121	0,01/10,00		Dati Input D2	147	-32767/+32767		
Scarto impulsi	122	-BMS/+BMS		Out dati gateway				
Valore impulsi	123	0,0/+8xBMS		Dati Output A1	148	-32767/+32767		
Input analogici				Dati Output A2	149	-32767/+32767		
Valore An In 1	96	-32767/+32767		Dati Output B1	150	-32767/+32767		
Scarto An In 1	97	-19,980/+19,980 volts		Dati Output B2	151	-32767/+32767		
Scala An In 1	98	-16,000/+16,000		Dati Output C1	152	-32767/+32767		
Bda ftrto An In 1	182	0,0/200,0 rad/sec		Dati Output C2	153	-32767/+32767		
Valore An In 2	99	-32767/+32767		Dati Output D1	154	-32767/+32767		
Scarto An In 2	100	-19,980/+19,980 volts		Dati Output D2	155	-32767/+32767		
Scala An In 2	101	-16,000/+16,000						
Bda ftrto An In 2	183	0,0/200,0 rad/sec						
Valore Input mA	102	-32767/+32767						
Scarto Input mA	103	-32,000/+32,000 mA						
Scala Input mA	104	-16,00						
Bda filtro in mA	184	0,0/200,0 rad/sec						
Output analogici								
Valore An Out 1	105	-32767/+32767						
Scarto An Out 1	106	-20,000/+20,000						
Scala An Out 1	107	-1,000/+1,000						
Valore An Out 2	108	-32767/+32767						
Scarto An Out 2	109	-19,980/+19,980 volts						

Nome	N.	Valore Min/Max	Nome	N.	Valore Min/Max
<b>Motore/Inverter</b>			Selez funzione	212	0/27
Targhetta motore			Output funz 1	213	Variabile
HP su targhetta	2	0,2 hp/2000,0 hp	Output funz 2	214	0/65535
RPM su targhetta	3	1 giri/min./1500 giri/min.	Input funzione 9	232	-32767/+32767
Amp su targhetta	4	0,1 amps/Calc	Input funzione 10	233	-32767/+32767
Volt su targhetta	5	75 volts/575 volts	<b>Rigen/contr bus</b>		
Hz su targhetta	6	1,0/250,0 Hz	Opz bus/frenagg	13	Selezione bit
Poli motore	7	2/40 poli	<b>Comp. Processo</b>		
Fattore servizio	9	1,00/2,00	Uscita compens.	48	-800,0/+800,0%
<b>Dati codificatore</b>			Rif. compens.	49	-800,0/+800,0%
Codificatore PPR	8	Calc/2000 ppr	Fdbk compens.	50	-800,0/+800,0%
<b>Inverter</b>			Selez. Compens.	51	Selezione bit
Frequenza PWM	10	1000 Hz/Da inverter	Banda filt comp	52	0,0/240,0 rad/sec
Amp inverter	11	0,1 amps/Da inverter	Pre caric compens	53	-800,0/+800,0%
Volt inverter	12	75/575 volts	Ki compensazione	54	0,000/16,000
<b>Costanti motore</b>			Kp compensazione	55	0,000/16,000
Resist. Statore	166	0,00/100,00%	Limite inf comp	58	-800,0/+800,0%
Indutt. Dispers.	167	0,00/100,00%	Limite sup comp	59	-800,0/+800,0%
Corrente flusso	168	0,00/75,00%	Guad usc compen	60	-8,000/+8,000
Guad scorrimento	169	0,0/400,0%	Comp vel max ind	61	-6 x /0,0 BMS giri/min.
Poli motore	7	2/40 poli	Comp vel max av	62	0,0 giri/min./+6xBMS giri/min.
<b>Applicazione</b>			<b>Avvio lanciato</b>		
Frenaggio flusso			Selez Avvio Vel	216	0/2
Opz bus/frenagg	13	Selezione bit	Veloc Avvio Vel	217	P40/P41
<b>Manten/frenagg CC</b>			<b>Autoregolazione</b>		
Opz bus/frenagg	13	Selezione bit	<b>Impost. Autoreg</b>		
Corrente fren CC	79	0,0%/Calc	Sel autoreg/diag	173	Selezione bit
Tempo frenagg CC	80	0,0/6553,5 sec	Config trns diag	172	Selezione bit
<b>Cor mtr 400%</b>			Coppia autoreg	164	250%/100,0%
Corrente max mtr	195	0/1	Vel. autoreg	165	0,3 x BMS/BMS
<b>Aum rapido flus</b>			<b>Stato autoreg</b>		
Opz bus/frenagg	13	Selezione bit	Stato autoregol	156	Selezione bit
Liv flusso rapid	78	100,0%/Calc	Diag invert 1	174	Selezione bit
<b>Tempo pre-avvio</b>			Diag invert 2	175	Selezione bit
Vel pre-avvio	193	-0,1 x / +0,1 x BMS	Errori autoreg	176	Selezione bit
Tpo pre-avvio	194	0,0/10,0 sec	<b>Risult autoreg</b>		
<b>Funzione Prog</b>			Resist. Statore	166	0,00/100,00%
Input funzione 1	198	Variabile	Indutt. Dispers	167	0,00/100,00%
Masch/val funz 1	199	Variabile	Corrente flusso	168	0,00/75,00%
Sel valut funz 1	200	0/17	Guad scorrim	169	0,0/400%
Input funzione 2	201	Variabile	Inerzia totale	157	0,0/655,00 sec
Masch/val funz 2	202	Variabile	Banda per vel.	161	0,00/Calc rad/sec
Sel valut funz 2	203	0/17			
Input funzione 3	204	Variabile			
Masch/val funz 3	205	Variabile			
Sel valut funz 3	206	0/17			
Input funzione 4	207	Variabile			
Input funzione 5	208	Variabile			
Input funzione 6	209	Variabile			

---

<b>Nome</b>	<b>N.</b>	<b>Valore Min/Max</b>	<b>Nome</b>	<b>N.</b>	<b>Valore Min/Max</b>
Input funzione 7	210	Variabile			
Input funzione 8	211	Selezione bit			

Questa pagina è stata lasciata intenzionalmente in bianco





Allen-Bradley, a Rockwell Automation Business, has been helping its customers improve productivity and quality for more than 90 years. We design, manufacture and support a broad range of automation products worldwide. They include logic processors, power and motion control devices, operator interfaces, sensors and a variety of software. Rockwell is one of the world's leading technology companies.

### Worldwide representation.



Argentina • Australia • Austria • Bahrain • Belgium • Brazil • Bulgaria • Canada • Chile • China, PRC • Colombia • Costa Rica • Croatia • Cyprus • Czech Republic • Denmark • Ecuador • Egypt • El Salvador • Finland • France • Germany • Greece • Guatemala • Honduras • Hong Kong • Hungary • Iceland • India • Indonesia • Ireland • Israel • Italy • Jamaica • Japan • Jordan • Korea • Kuwait • Lebanon • Malaysia • Mexico • Netherlands • New Zealand • Norway • Pakistan • Peru • Philippines • Poland • Portugal • Puerto Rico • Qatar • Romania • Russia-CIS • Saudi Arabia • Singapore • Slovakia • Slovenia • South Africa, Republic • Spain • Sweden • Switzerland • Taiwan • Thailand • Turkey • United Arab Emirates • United Kingdom • United States • Uruguay • Venezuela • Yugoslavia

Allen-Bradley Headquarters, 1201 South Second Street, Milwaukee, WI 53204 USA, Tel: (1) 414 382-2000 Fax: (1) 414 382-4444



# Guia de Inicialização Rápida 1336 IMPACT

Este Guia de Inicialização Rápida resume as etapas necessárias para instalar, inicializar e programar o Inversor de Frequência Ajustável CA 1336 IMPACT. As informações fornecidas NÃO substituem o Manual do Usuário e destinam-se unicamente ao pessoal qualificado de manutenção de inversores. Consulte o Manual do Usuário do 1336 IMPACT (publicação 1336 IMPACT-5.0) para maiores detalhes sobre outras considerações das aplicações e precauções relacionadas.

## Fiação de Alimentação – TB1

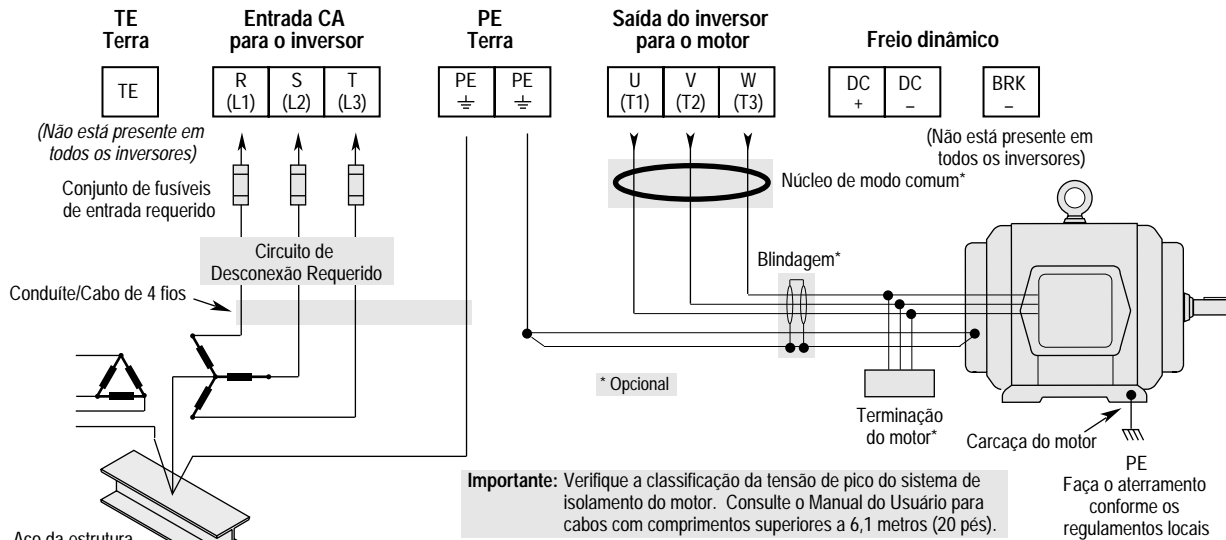

O diagrama mostra as conexões que são comuns para todos os inversores. Consulte o Manual do Usuário para maiores detalhes.

## Localização dos Jumpers

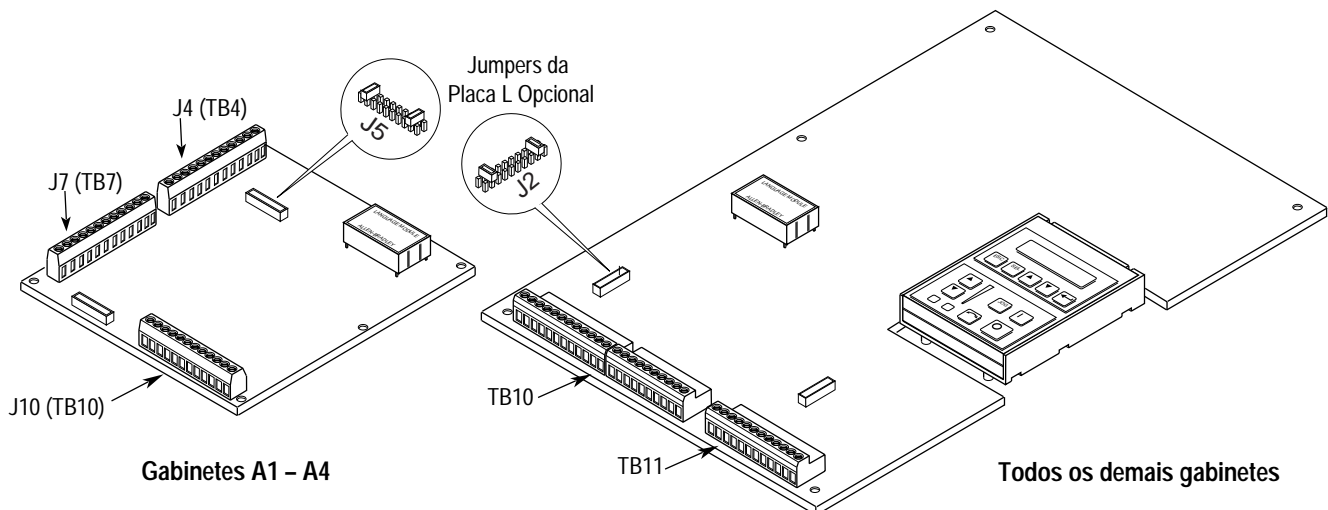

## Fiação E/S – Gabinete - A

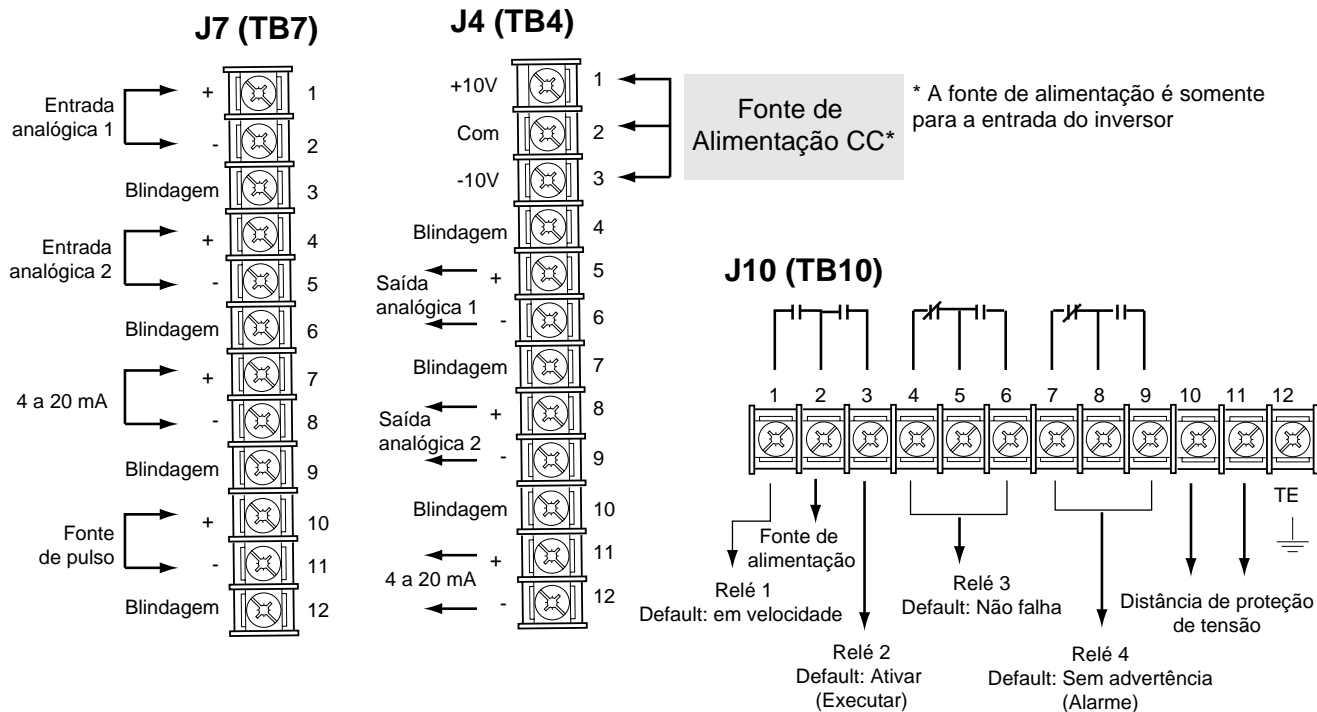

## Fiação E/S – Todos os demais gabinetes

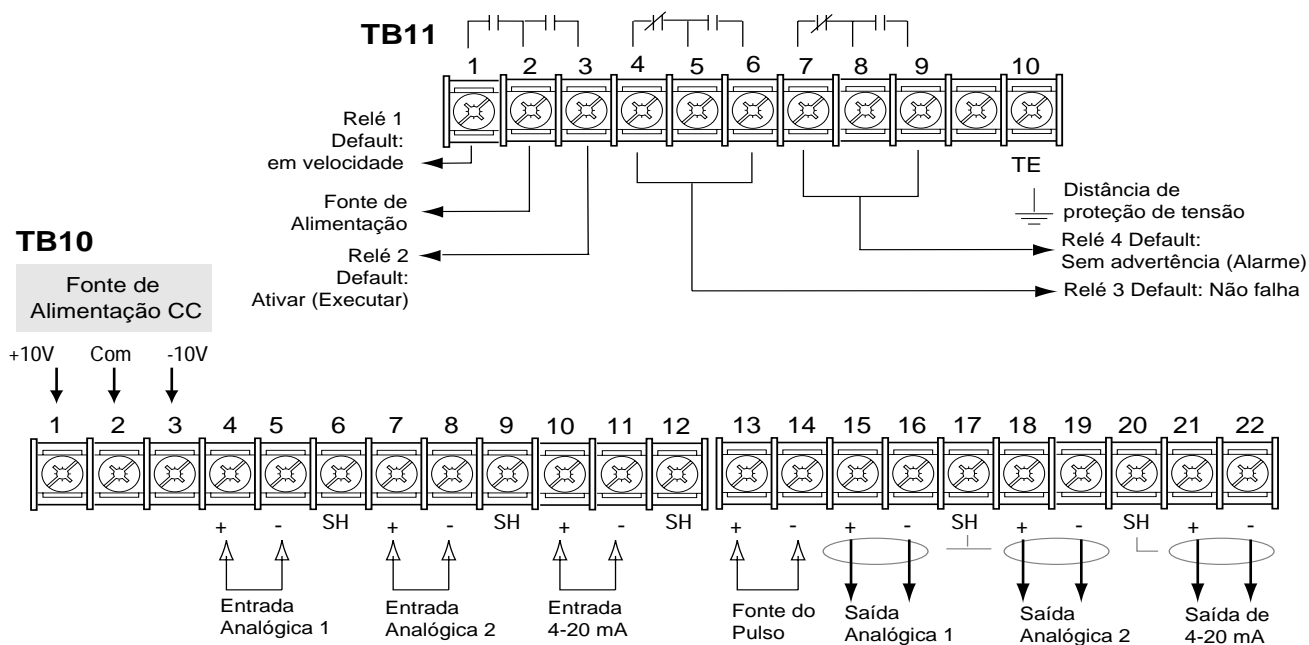

## Placa L Opcional

1	Status	Parar/Remover falha	Status	Status	Status	Status	Status	Status	Ativar
2	Partida	Parar/Remover falha	Para trás/Para frente	Jog	Ext Fit	Vel Sel 3	Vel Sel 2	Vel Sel 1	Ativar
3	Partida	Parar/Remover falha	Para trás/Para frente	Tipo Parada	Ext Fit	Vel Sel 3	Vel Sel 2	Vel Sel 1	Ativar
4	Partida	Parar/Remover falha	Para trás/Para frente	Acel 2*/1	Ext Fit	Desac 2*/1	Vel Sel 2	Vel Sel 1	Ativar
5	Partida	Parar/Remover falha	Para trás/Para frente	Incr MOP	Ext Fit	Dim MOP	Vel Sel 2	Vel Sel 1	Ativar
6	Partida	Parar/Remover falha	Para trás/Para frente	Jog	Ext Fit	Loc/Rem	Vel Sel 2	Vel Sel 1	Ativar
7	Partida	Parar/Remover falha	Reverso	Para frente	Ext Fit	Jog	Vel Sel 2	Vel Sel 1	Ativar
8	Partida	Parar/Remover falha	Reverso	Para frente	Ext Fit	Vel Sel 3	Vel Sel 2	Vel Sel 1	Ativar
9	Partida	Parar/Remover falha	Incr MOP	Dim MOP	Ext Fit	Vel Sel 3	Vel Sel 2	Vel Sel 1	Ativar
10	Partida	Parar/Remover falha	Reverso	Para frente	Ext Fit	Incr MOP	Dim MOP	Vel Sel 1	Ativar
11	Partida	Parar/Remover falha	Acel 1	Acel 2	Ext Fit	Desac 1	Desac 2	Vel Sel 1	Ativar
12	Executar para frente	Parar/Remover falha	Exec Rev	Loc/Rem	Ext Fit	Vel Sel 3	Vel Sel 2	Vel Sel 1	Ativar
13	Executar para frente	Parar/Remover falha	Exec Rev	Tipo Parada	Ext Fit	Vel Sel 3	Vel Sel 2	Vel Sel 1	Ativar
14	Executar para frente	Parar/Remover falha	Exec Rev	Acel 2*/1	Ext Fit	Desac 2*/1	Vel Sel 2	Vel Sel 1	Ativar
15	Executar para frente	Parar/Remover falha	Exec Rev	Incr MOP	Ext Fit	Dim MOP	Vel Sel 2	Vel Sel 1	Ativar
16	Executar para frente	Parar/Remover falha	Exec Rev	Loc/Rem	Ext Fit	Tipo Parada	Vel Sel 2	Vel Sel 1	Ativar
17	Partida	Parar/Remover falha	Para trás/Para frente	PTrim En	Ext Fit	Desac Rampa	Vel Sel 2	Vel Sel 1	Ativar
18	Partida	Parar/Remover falha	Para trás/Para frente	Fluxo Ativ	Ext Fit	Reaj	Vel Sel 2	Vel Sel 1	Ativar
19	Partida	Parar/Remover falha	Vel/Trq 3	Vel/Trq 2	Ext Fit	Vel/Trq 1	PTrim En	Vel Sel 1	Ativar
20	Partida	Parar/Remover falha	Vel/Trq 3	Vel/Trq 2	Ext Fit	Vel/Trq 1	Fluxo Ativ	Vel Sel 1	Ativar
21	Partida	Parar/Remover falha	Reverso	Para frente	Ext Fit	Desac Rampa	Reaj	Vel Sel 1	Ativar
22	Partida	Parar/Remover falha	Vel/Trq 3	Vel/Trq 2	Ext Fit	Vel/Trq 1	Vel Sel 2	Vel Sel 1	Ativar
23	Executar para frente	Parar/Remover falha	Exec Rev	PTrim En	Ext Fit	Reaj	Vel Sel 2	Vel Sel 1	Ativar
24	Executar para frente	Parar/Remover falha	Exec Rev	Fluxo Ativ	Ext Fit	Reaj	Vel Sel 2	Vel Sel 1	Ativar
25	Executar para frente	Parar/Remover falha	Exec Rev	PTrim En	Ext Fit	Desac Rampa	Vel Sel 2	Vel Sel 1	Ativar
26	Executar para frente	Parar/Remover falha	Exec Rev	Jog	Ext Fit	Vel Sel 3	Vel Sel 2	Vel Sel 1	Ativar
27	Partida	Parar/Remover falha	Para trás/Para frente	Incr MOP	Ext Fit	Dim MOP	Vel Sel 2	Vel Sel 1	Ativar
28	Partida	Parar/Remover falha	Incr MOP	Dim MOP	Ext Fit	Vel Sel 3	Vel Sel 2	Vel Sel 1	Ativar
29	Partida	Parar/Remover falha	Reverso	Para frente	Ext Fit	Incr MOP	Dim MOP	Vel Sel 1	Ativar
30	Executar para frente	Parar/Remover falha	Exec Rev	Incr MOP	Ext Fit	Dim MOP	Vel Sel 2	Vel Sel 1	Ativar

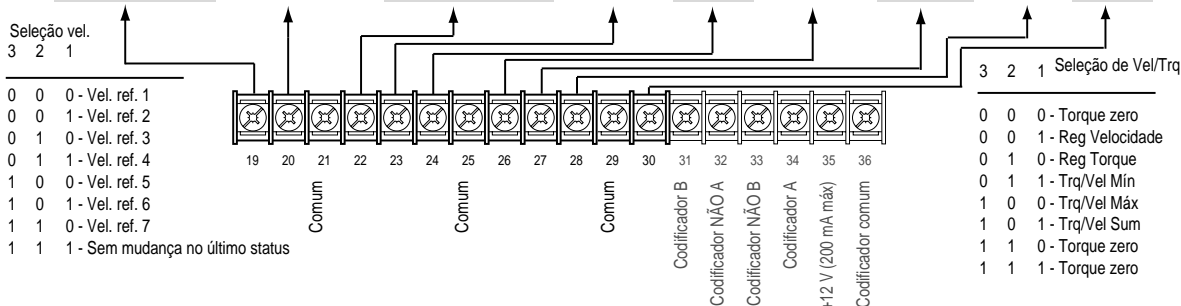

## Start-up

Este procedimento de start-up abrange os valores mais comuns utilizando-se o modo de start-up do 1336 IMPACT. Consulte o Manual do Usuário para informações detalhadas.

O procedimento a seguir foi escrito para os usuários que possuem a Interface de Operação e Programação instalada. Para usuários sem a interface, deve-se fornecer os respectivos sinais e comandos externos. Considera-se também que todos os parâmetros estejam nos valores definidos de fábrica.



**ATENÇÃO:** É necessário fornecer alimentação para o inversor para realizar o seguinte procedimento. Algumas das tensões presentes estão no potencial da linha de entrada. Somente pessoas qualificadas na manutenção devem realizar o procedimento a seguir, para evitar o perigo de choques ou danos no equipamento. Antes de iniciar, leia e compreenda completamente o procedimento. Se não ocorrer um evento durante a realização desse procedimento, NÃO prossiga. Remova a alimentação abrindo o circuito de desconexão e corrija o problema antes de continuar.



**ATENÇÃO:** Verifique se a tensão nos capacitores de barramento está descarregada a fim de evitar o perigo de choque elétrico ao fazer a fiação ou manutenção do inversor. Meça a tensão do barramento CC nos terminais + e - do TB1. A tensão deve ser zero.

1. Verifique se a alimentação da linha CA e a alimentação de controle correspondem à classificação do inversor.
2. Se a opção L estiver instalada, verifique se as entradas de intertravamento de Habilitação e Parada estão presentes. Caso esta opção não esteja instalada, verifique se os jumpers estão instalados nos pinos 3 e 4 e 17 e 18 no J5 nos inversores de Gabinete A ou J2 nos inversores de Gabinete. Consulte as localizações dos Jumpers.
3. Se a E/S Padrão estiver sendo usada, verifique se os jumpers estão com a fiação correta.
4. Se a opção analógica estiver instalada, verifique se os parâmetros estão devidamente configurados (consulte o Manual do Usuário).



**ATENÇÃO:** Poderá ocorrer a rotação do motor em todas as etapas seguintes. Para se proteger contra lesões, rotação incorreta e possível dano ao equipamento, leia e execute cada uma das etapas seguintes com cuidado.

5. Forneça a alimentação CA para o inversor. O display LCD deverá acender e exibir o status “Stopped (Parado)” do inversor e uma frequência de saída de “+0,00 Hz”. Se o inversor detectar alguma falha, uma mensagem referente à falha será exibida na tela. Registre a informação, remova a alimentação e corrija a fonte de falha antes de proceder.
6. A partir de Status Display (Exibição do Status), pressione a tecla Enter (ou qualquer outra tecla). Será exibido “Choose Mode” (Selecione Modo). Pressione as teclas para cima/para baixo, até que seja exibido “Startup” (Partida). Selecione Enter.

**Importante:** Todas as questões respondidas com Yes (Sim) ou No (Não). Ao pressionar Enter será selecionado o padrão definido de fábrica (“Y” ou “N”) (S ou N). Para alterar a seleção, pressione as teclas para cima/para baixo. Pressione Enter para selecionar. Ao selecionar “Y” você terá condições de continuar na mesma etapa e, ao selecionar “N”, você prosseguirá para a etapa seguinte. A figura abaixo mostra as etapas envolvidas.

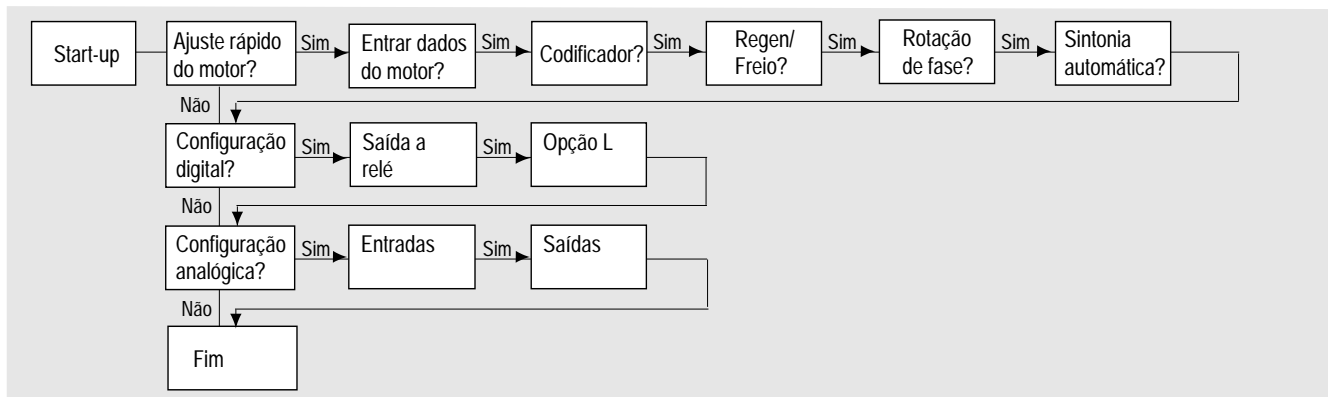

**Importante:** Observe o seguinte:

- Para sair do modo “Startup” (Partida) a qualquer momento, pressione a tecla ESCape até que seja exibido “Status Display” (Display de Status). Se desejar retornar ao modo de Startup, basta selecionar “Reset Sequence” (Reset da Seqüência) para começar do início. Ao selecionar “Continue” (Continuar) pode-se recomeçar a partir do ponto em que se tinha parado.
  - Ao completar a última ação de uma etapa, a etapa seguinte começa automaticamente.
  - Ao pressionar SElect (Selecionar) a linha 2 da tela será ativada. Isso deve ser feito para todos os valores.
  - Pressione as teclas para cima/para baixo para ajustar o valor (pule essa etapa se o valor estiver correto). Pressione Enter para salvar o valor ou manter o valor existente. Pressione ENTER novamente, para avançar para a próxima etapa (parâmetro).
7. Desligue e ligue novamente para ativar as mudanças. Isso completa o procedimento “Assisted Startup” (Partida com Assistência). Dependendo da sua aplicação, poderá ser necessária a programação de outros parâmetros e/ou “Advanced Startup” (Partida Avançada). Consulte o Manual do Usuário para maiores detalhes.

## Dimensões do inversor

Para determinar o tamanho do inversor, veja a ilustração e tabela abaixo.

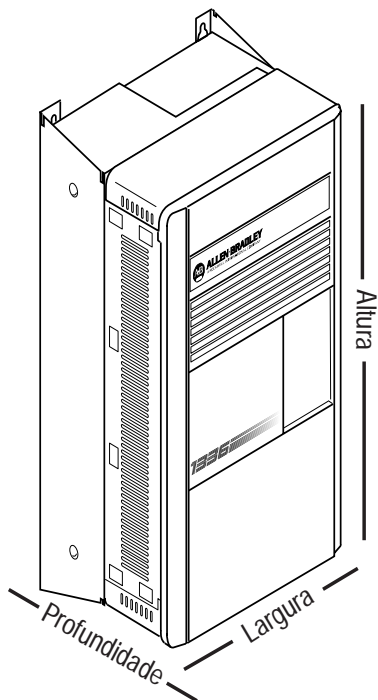

Gabinete	Largura x Altura x Profundidade Milímetros (polegadas)
A1	215,9 (8,50) x 290,0 (11,42) x 160,0 (6,30)
A2	215,9 (8,50) x 290,0 (11,42) x 180,5 (7,10)
A3	215,9 (8,50) x 290,0 (11,42) x 207,0 (8,15)
A4	260,0 (10,24) x 350,0 (13,78) x 212,0 (8,35)
B	276,4 (10,88) x 476,3 (18,75) x 225,0 (8,86)
C	301,8 (11,88) x 701,0 (27,60) x 225,0 (8,86)
D	381,5 (15,02) x 1240,0 (48,82) x 270,8 (10,66)
E-fechado	511,0 (20,12) x 1498,6 (59,00) x 477,5 (18,80)
E-aberto	511,0 (20,12) x 1498,6 (59,00) x 372,6 (14,67)
F	762,0 (30,00) x 2286,0 (90,00) x 635,0 (25,00)
G	762,0 (30,00) x 2387,6 (94,0) x 635,0 (25,00)
H	1270,0 (50) x 2324,1 (91,50) <sup>①</sup> x 635,0 (25)

<sup>①</sup> A altura do ventilador (635,0 (25,00)) não está incluída.

## Operação da Interface de Operação e Programação

A visualização ou programação dos parâmetros é realizada através dos modos Program (Programação) ou Display mostrados abaixo.

1. A partir de Status Display, pressione para exibir "Choose Mode".

2. Pressione ou para exibir "Program" ou "Display".

3. Pressione .

4. Pressione ou até que o arquivo desejado seja exibido.

5. Pressione .

6. Pressione ou até que o grupo desejado seja exibido.

7. Pressione .

8. Pressione ou para exibir o parâmetro desejado.

## Estrutura da Interface de Operação e Programação (HIM)

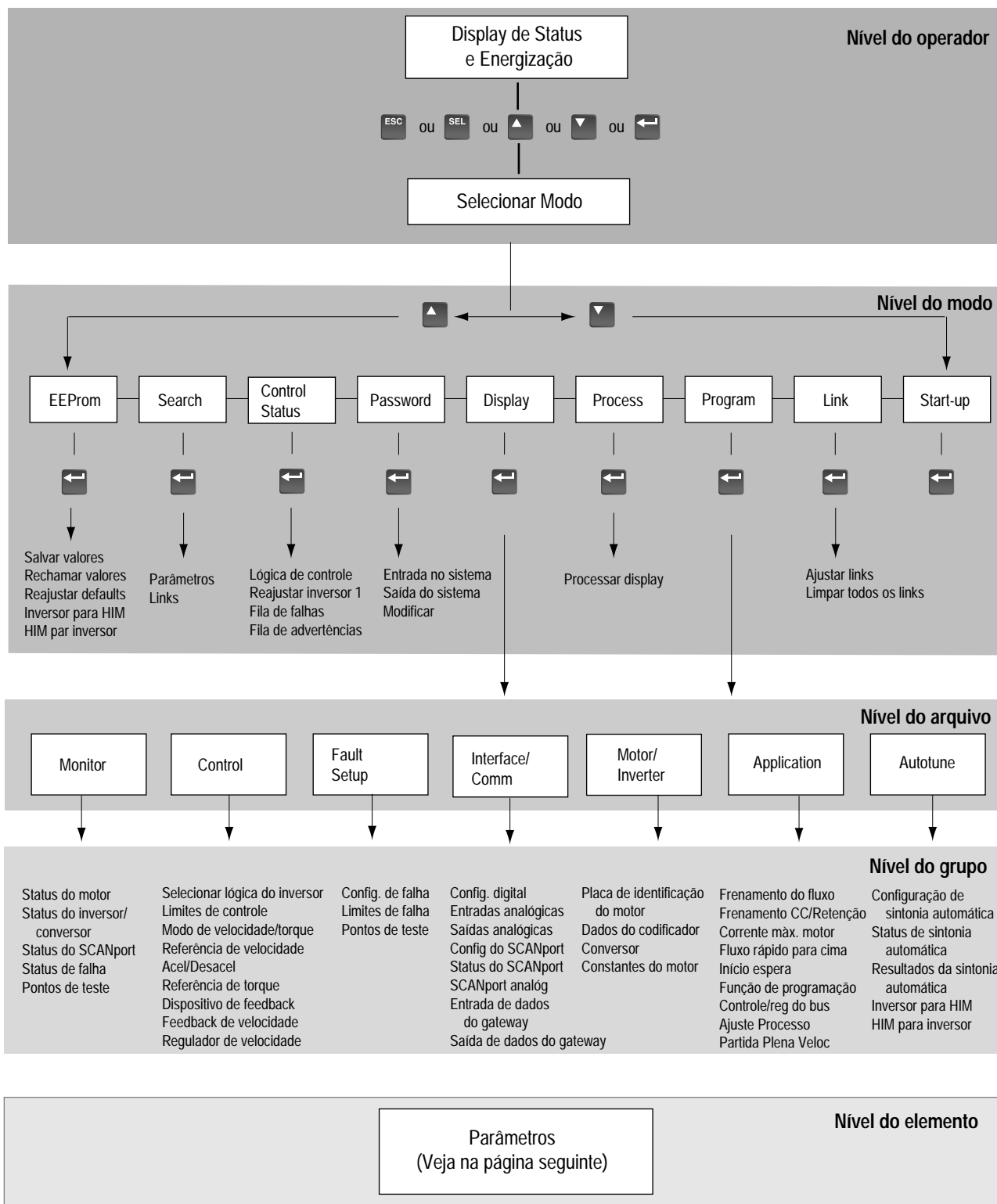

## Parâmetros – Arquivos, Grupos e Elementos

Nome	No.	Valor Mín./Máx.	Nome	No.	Valor Mín./Máx.
<b>Monitorização</b>			Lim Cor Neg Mot	73	Calc/0,0%
Status do motor			Lim Torque Pos	74	0,0%/Calc
Velocidade do motor	81	-8 x BMS/+8 x BMS	Lim Torque Neg	75	Calc/0,0%
Frequência do motor	89	-250,000/+250,000 Hz	Lim Poten Realim	76	-800,0%/0,0%
Corrente do motor	83	0,0/6553,5 amps	Lim Variação Cor	77	Calc/200,0%
Tensão do motor	85	0/+3000 volts	Corrente Mot Máx.	195	0/1
% tensão do motor	234	0/800%	Limite vel. mín	215	0,0/BMS rpm
% torque do motor	86	-800,0/+800,0%	<b>Modo Veloc/Torq</b>		
% fluxo do motor	88	12,5/100,0%	Sel modo veloc/torq	68	0/5
% força do motor	90	-800,0/+800,0%	<b>Referência velocidade</b>		
Baixo fdbk pos fech	227	0/65535	Ref. velocidade 1	29	-8x/+8xBMS rpm
Alto fdbk pos fech	228	0/65535	Mult. veloc. 1	30	-3,9999/+3,9999
Ref torque int	229	-800/+800%	Velocidade ref. 2	31	-8x/+8xBMS rpm
<b>Status inversor/conversor</b>			Velocidade ref. 3	32	-8x/+8xBMS rpm
Tensão barra CC	84	0/1000 volts	Velocidade ref. 4	33	-8x/+8xBMS rpm
Stat entrada lógica	14	Bit selection	Velocidade ref. 5	34	-8x/+8xBMS rpm
Stat inversor/conversor	15	Bit selection	Velocidade ref. 6	35	-8x/+8xBMS rpm
Stat inversor/conversor 2	196	Bit selection	Velocidade ref. 7	36	-8x/+8xBMS rpm
Stat inibição execução	16	Bit selection	Mult. veloc. 7	37	-3,9999/+3,9999
Status veloc comando	82	-8 x BMS/+8 x BMS	Velocidade jog 1	38	-8x/+8xBMS rpm
Stat limite torque	87	Bit selection	Velocidade jog 2	39	-8x/+8xBMS rpm
Saída reg veloc	225	-300,0/+300,0%	<b>Acel/Desacel</b>		
Erro veloc	226	-8 x BMS/+8 x BMS	Tempo acel 1	42	0,0/6553,5 sec
<b>Stat SCANport</b>			Tempo acel 2	43	0,0/6553,5 sec
Cont Inic/Parar	128	Bit selection	Tempo desacel 1	44	0,0/6553,5 sec
Prop partida/parada	129	Bit selection	Tempo desacel 2	45	0,0/6553,5 sec
Cont Jog1/Jog2	130	Bit selection	Percent curva S	47	0,0/100,0%
Cont Ramp/ApFalh	131	Bit selection	<b>Referência torque</b>		
Cont Flux/Aju	132	Bit selection	Ref. torque 1	69	-800,0/+800,0%
<b>Status de falha</b>			% Mult Torque	70	-200,00/+200,00%
Status falha energ	219	Bit selection	<b>Dispos Aliment</b>		
Status falha não config.	220	Bit selection	Tipo Dispos Aliment	64	1/3
Status falha 1	221	Bit selection	PPR Codificador	8	Calc/20000 ppr
Status falha 2	222	Bit selection	<b>Realim Veloc</b>		
Status advertência 1	223	Bit selection	Realim Vel Mul	63	-32767/+32767
Status advertência 2	224	Bit selection	Sel Filtr Realim	65	0/4
<b>Pontos de teste</b>			Gan Filtr Realim	66	-5,00/+5,00
Dados teste 1	92	-32768/+32767	LF Filtro Realim	67	0,2/900,0 rad/sec
Seleção teste 1	93	0/65535	Frq Filtr Sintn	185	5,0/135,0 Hz
Dados teste 2	94	-32768/+32767	Q Filtro Sintn	186	2/500
Seleção teste 2	95	0/65535	<b>Regulador veloc</b>		
<b>Controle</b>			Inércia total	157	0,01 sec/655,00 sec
Sel Lógic Acion			LF Circ Velocid	161	0,00 rad/sec/Calc
Opções lógica	17	Bit selections	Ki Circ Velocid	158	0,0/4095,9
Tempo Esp Parad	18	0,0/10,0 sec	Kp Circ Velocid	159	0,0/200,0
Faixa Vel Zero	19	0,0 rpm/8xBMS rpm	Kf Circ Velocid	160	0,500/1,000
Vel Inic Espera	193	-0,1/+0,1 x BMS	LF Filtro Erro	162	Calc/1500,0 rad/sec
Tempo Ini Espera	194	0,0/10,0 sec	Queda percentual	46	0,0/25,5%
<b>Limites de controle</b>			<b>Prep Falha</b>		
Limite Vel Rev	40	-6xBMS rpm/0,0 rpm	Config Falha		
Lim Vel Frente	41	0,0 rpm/+6xBMS rpm	Seleção Falha 1	20	Bit selection
Lim Cor Pos Mot	72	0,0%/Calc	Seleção Adv 1	21	Bit selection

1336 IMPACT Guia de Inicialização Rápida

Nome	No.	Valor Mín./Máx.	Nome	No.	Valor Mín./Máx.
<b>Config Falha (cont.)</b>			<b>Config SCANport</b>		
Seleção falha 2	22	Bit Selection	Fio SP 2 Ativado	181	Bit Selection
Seleção Adv 2	23	Bit Selection	Másc Ativação SP	124	Bit Selection
<b>Limites falha</b>			Másc Dir/Ref	125	Bit Selection
Ultrap Vel Máx	24	0,0 rpm/BMS rpm	Másc Iniciar/Jog	126	Bit Selection
Tempo Mot Parado	25	0,1/3276,7 sec	Másc Apa Fal/Rei	127	Bit Selection
% Sobrec Motor	26	110,0/400,0%	<b>Status SCANport</b>		
Subtensão Linha	27	10,0/90,0%	Cont Dir/Ref	128	Bit selection
<b>Pontos de Teste</b>			Cont Inic/Parar	129	Bit selection
Dados Teste 1	92	-32768/+32768	Cont Jog1/Jog2	130	Bit selection
Seleção Teste 1	93	0/65535	Cont Ramp/ApFalh	131	Bit selection
Dados Teste 2	94	-32768/+32767	Cont Flux/Ajus	132	Bit selection
Seleção Teste 2	95	0/65535	<b>SCANport Analóg</b>		
<b>Interface/Com</b>			Sel SP Ana Ent 1	133	1/16
<b>Config Digital</b>			Val SP Ana Ent 1	134	-32767/+32767
Config Relé	114	0/38	Fat SP Ana Ent 1	135	-1,000/+1,000
Config Relé 1	115	-800,0/+800,0%	Sel SP Ana Ent 2	136	1/16
Config Relé 2	187	0/36	Val SP Ana Ent 2	137	-32767/+32767
Parâmetro Relé 2	188	-800,0/+800,0	Fat SP Ana Ent 2	138	-1,000/+1,000
Config Relé 3	189	0/36	Saída Ana SP	139	-32767/+32767
Parâmetro Relé 3	190	-800,0/+800,0	<b>Gateway Entrada Dados</b>		
Config Relé 4	191	0/36	Dados Ent A1	140	-32767/+32767
Parâmetro Relé 4	192	-800/+800,0%	Dados Ent A2	141	-32767/+32767
Modo Opção L	116	1/25	Dados Ent B1	142	-32767/+32767
Stat Ent Opcao L	117	Bit Selection	Dados Ent B2	143	-32767/+32767
Mudanca Pot Man	118	0,0/BMS	Dados Ent C1	144	-32767/+32767
Valor Pot Man	119	0,0/BSMNA	Dados Ent C2	145	-32767/+32767
PPR Pulsos Ent	120	500/2000	Dados Ent D1	146	-32767/+32767
Fator Pulsos Ent	121	0,01/10,00	Dados Ent D2	147	-32767/+32767
Offset Pulso Ent	122	-BMS/+BMS	<b>Gateway Saída Dados</b>		
Val Pulsos Ent	123	0,0/+8xBMS	Dados Saída A1	148	-32767/+32767
<b>Entradas Analóg</b>			Dados Saída A2	149	-32767/+32767
Valor Ana Ent 1	96	-32767/+32767	Dados Saída B1	150	-32767/+32767
Offset Ana Ent 1	97	-19,980/+19,980 volts	Dados Saída B2	151	-32767/+32767
Fator Ana Ent 1	98	-16,000/+16,000	Dados Saída C1	152	-32767/+32767
LF Filtr Ana Ent 1	182	0,0/200,0 rad/sec	Dados Saída C2	153	-32767/+32767
Valor Ana Ent 2	99	-32767/+32767	Dados Saída D1	154	-32767/+32767
Offset Ana Ent 2	100	-19,980/+19,980 volts	Dados Saída D2	155	-32767/+32767
Fator Ana Ent 2	101	-16,000/+16,000			
LF Filtr Ana Ent 2	183	0,0/200,0 rad/sec			
Valor Entrada mA	102	-32767/+32767			
Offset Ent mA	103	-32,000/+32,000 mA			
Fator Ent mA	104	-16,00			
LF Filtr Ent mA	184	0,0/200,0 rad/sec			
<b>Saídas Analog</b>					
Val Ana Saída 1	105	-32767/+32767			
Offst Ana Saída 1	106	-20,000/+20,000			
Fator Ana Saída 1	107	-1,000/+1,000			
Val Ana Saída 2	108	-32767/+32767			
Offst Ana Saída 2	109	-19,980/+19,980 volts			
Fator Ana Saída 2	110	-1,000/+1,000			
Valor Saída mA	111	-32767/+32767			
Offset Saída mA	112	-32,000/+32,000 mA			
Fator Saída mA	113	-1,000/+1,000			

Nome	No.	Valor Min./Máx.	Nome	No.	Valor Min./Máx.
<b>Motor/Inversor</b>			Sel Função	212	0/27
Placa-Id Motor			Saída 1 Função	213	Varies
HP Placa-Id	2	0,2 hp/2000,0 hp	Saída 2 Função	214	0/65535
RPM Placa-Id	3	1 rpm/1500 rpm	Ent 9 Função	232	-32767/+32767
Amps Placa-Id	4	0,1 amps/Calc	Ent 10 Função	233	-32767/+32767
Volts Placa-Id	5	75 volts/575 volts	<b>Controle Reg Barra</b>		
Hz Placa-Id	6	1,0/250,0 Hz	Opções Barr/Freio	13	Bit selection
Polos do Motor	7	2/40 poles	<b>Processo Ajuste</b>		
Fator serviço	9	1,00/2,00	Saída AjustProc	48	-800,0/+800,0%
<b>Dados codificador</b>			Referên AjustProc	49	-800,0/+800,0%
PPR Codificador	8	Calc/2000 ppr	ReAlim AjustProc	50	-800,0/+800,0%
<b>Inversor</b>			Seleção AjustProc	51	Bit selection
Frequência PWM	10	1000 Hz/From drive	LF Filtro AjustProc	52	0,0/240,0 rad/sec
Amps Inversor	11	0,1 amps/From drive	Precarr AjustProc	53	-800,0/+800,0%
Volts Inversor	12	75/575 volts	Ki AjustProc	54	0,000/16,000
<b>Constantes motor</b>			Kp AjustProc	55	0,000/16,000
Resistnc Estator	166	0,00/100,00%	Lim Inf AjustPro	58	-800,0/+800,0%
Indutanc Disper	167	0,00/100,00%	Lim Sup AjustPro	59	-800,0/+800,0%
Corrente Fluxo	168	0,00/75,00%	Gan Saíd AjustPro	60	-8,000/+8,000
Ganho Desvio	169	0,0/400,0%	Ajust Vel Rev Máx	61	-6 x /0,0 BMS rpm
Polos do motor	7	2/40 poles	Ajust Vel Fre Máx	62	0,0 rpm/+6xBMS rpm
<b>Aplicativo</b>			<b>Partida Plena Vel</b>		
Freio fluxo			Seleção PartPlnVel	216	0/2
Opções Barr/Freio	13	Bit selection	Seleção PartPlnVel	217	P40/P41
Freio/Trava CC			<b>Sintonia Automática</b>		
Opções Barr/Freio	13	Bit selection	Instal Sint Auto		
Corrente CC freio	79	0,0%/Calc	Sel SintAut/Diag	173	Bit selection
Tempo freio CC	80	0,0/6553,5 sec	Config Diag Tran	172	Bit selection
<b>400% corrente motor</b>			Torque Sint Auto	164	250%/100,0%
Corrente Mot Máx	195	0/1	Veloc Sint Auto	165	0,3 x BMS/BMS
<b>Ráp Subd Flux</b>			<b>Status Sint Auto</b>		
Opções Barr/Freio	13	Bit selection	Status Sint Auto	156	Bit selection
Nível Flux Ráp	78	100,0%/Calc	Inversor Diag 1	174	Bit selection
<b>Início espera</b>			Inversor Diag 2	175	Bit selection
Vel Inic Espera	193	-0,1 x / +0,1 x BMS	Erros SintAuto	176	Bit selection
Tempo Ini Espera	194	0,0/10,0 sec	<b>Result Sint Auto</b>		
<b>Função Prog</b>			Resistnc Estator	166	0,00/100,00%
Ent 1 Função	198	Varies	Indutanc Disper	167	0,00/100,00%
Mas/Val Funç 1	199	Varies	Corrente Fluxo	168	0,00/75,00%
Sel Aval Funç 1	200	0/17	Ganho Desvio	169	0,0/400%
Ent 2 Função	201	Varies	Inércia Total	157	0,0/655,00 sec
Mas/Val Func 2	202	Varies	LF Circ Velocid	161	0,00/Calc rad/sec
Sel Aval Func 2	203	0/17			
Ent 3 Função	204	Varies			
Mas/Val Func 3	205	Varies			
Sel Aval Func 3	206	0/17			
Ent 4 Função	207	Varies			
Ent 5 Função	208	Varies			
Ent 6 Função	209	Varies			
Ent 7 Função	210	Varies			
Ent 8 Função	211	Bit selection			



Allen-Bradley, a Rockwell Automation Business, has been helping its customers improve productivity and quality for more than 90 years. We design, manufacture and support a broad range of automation products worldwide. They include logic processors, power and motion control devices, operator interfaces, sensors and a variety of software. Rockwell is one of the world's leading technology companies.

### Worldwide representation.



Argentina • Australia • Austria • Bahrain • Belgium • Brazil • Bulgaria • Canada • Chile • China, PRC • Colombia • Costa Rica • Croatia • Cyprus • Czech Republic • Denmark • Ecuador • Egypt • El Salvador • Finland • France • Germany • Greece • Guatemala • Honduras • Hong Kong • Hungary • Iceland • India • Indonesia • Ireland • Israel • Italy • Jamaica • Japan • Jordan • Korea • Kuwait • Lebanon • Malaysia • Mexico • Netherlands • New Zealand • Norway • Pakistan • Peru • Philippines • Poland • Portugal • Puerto Rico • Qatar • Romania • Russia-CIS • Saudi Arabia • Singapore • Slovakia • Slovenia • South Africa, Republic • Spain • Sweden • Switzerland • Taiwan • Thailand • Turkey • United Arab Emirates • United Kingdom • United States • Uruguay • Venezuela • Yugoslavia

Allen-Bradley Headquarters, 1201 South Second Street, Milwaukee, WI 53204 USA, Tel: (1) 414 382-2000 Fax: (1) 414 382-4444

Esta Guía rápida resume los pasos básicos necesarios para la instalación, arranque y programación del Variador de velocidad CA de frecuencia ajustable 1336 IMPACT. La información aquí proporcionada no sustituye de ninguna manera lo estipulado en el Manual del usuario y está dirigida únicamente a personal calificado que preste servicio al variador. Consulte el Manual del usuario 1336 IMPACT (publicación 1336 IMPACT-5.0) para obtener mayores detalles sobre otras consideraciones de aplicación y precauciones pertinentes.

## Cableado de la potencia – TB1

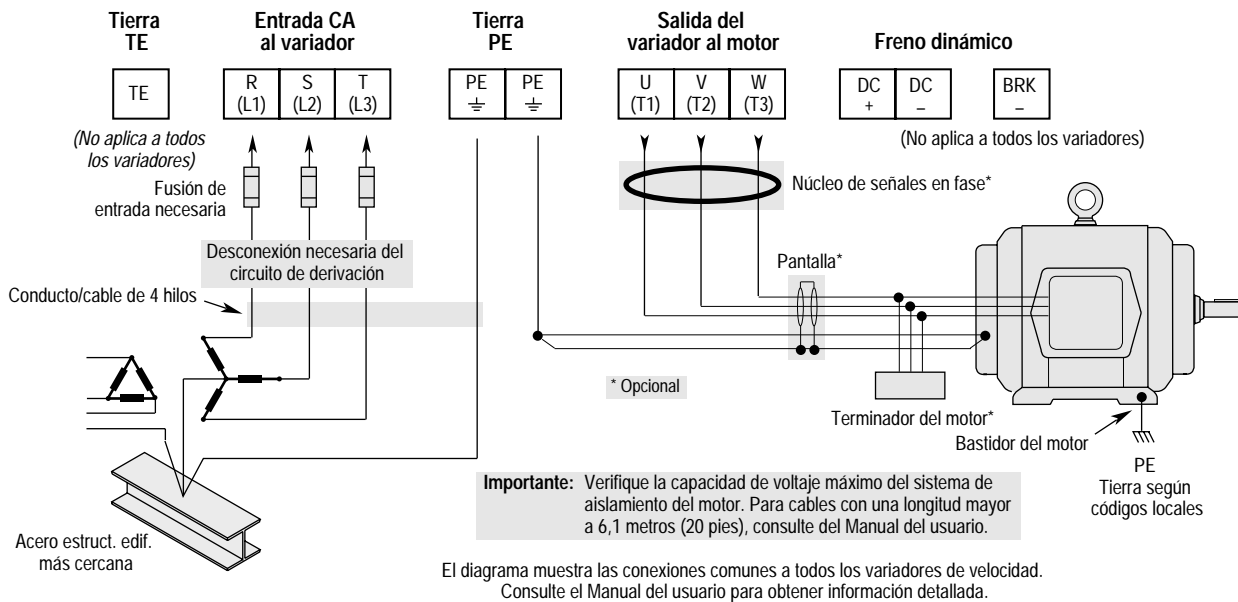

## Ubicación de los puentes conectores

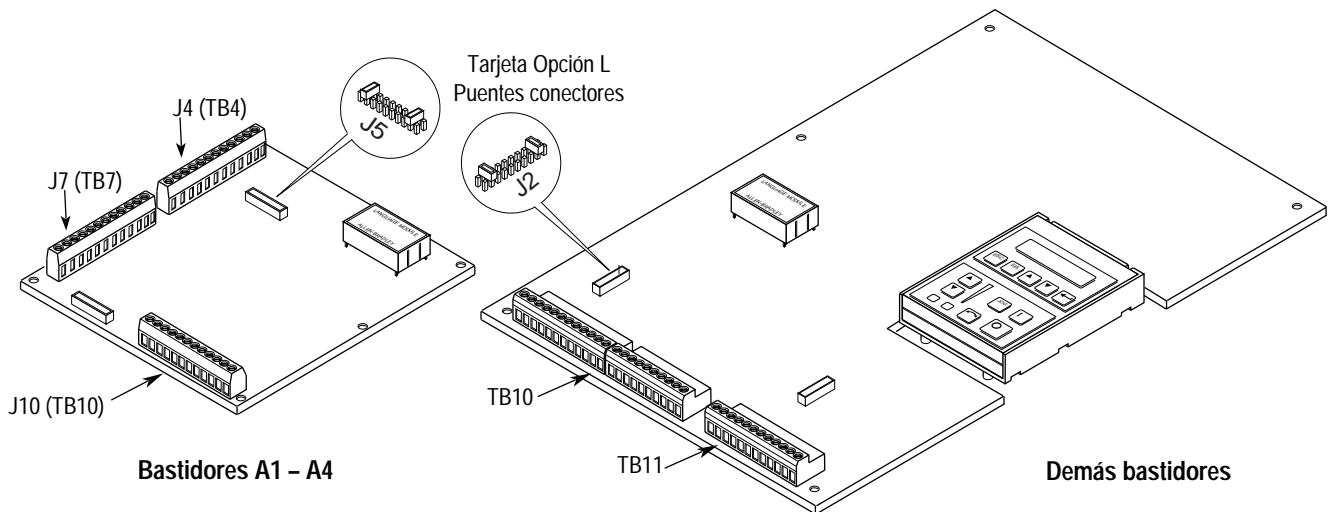

## Cableado E/S – Bastidores A

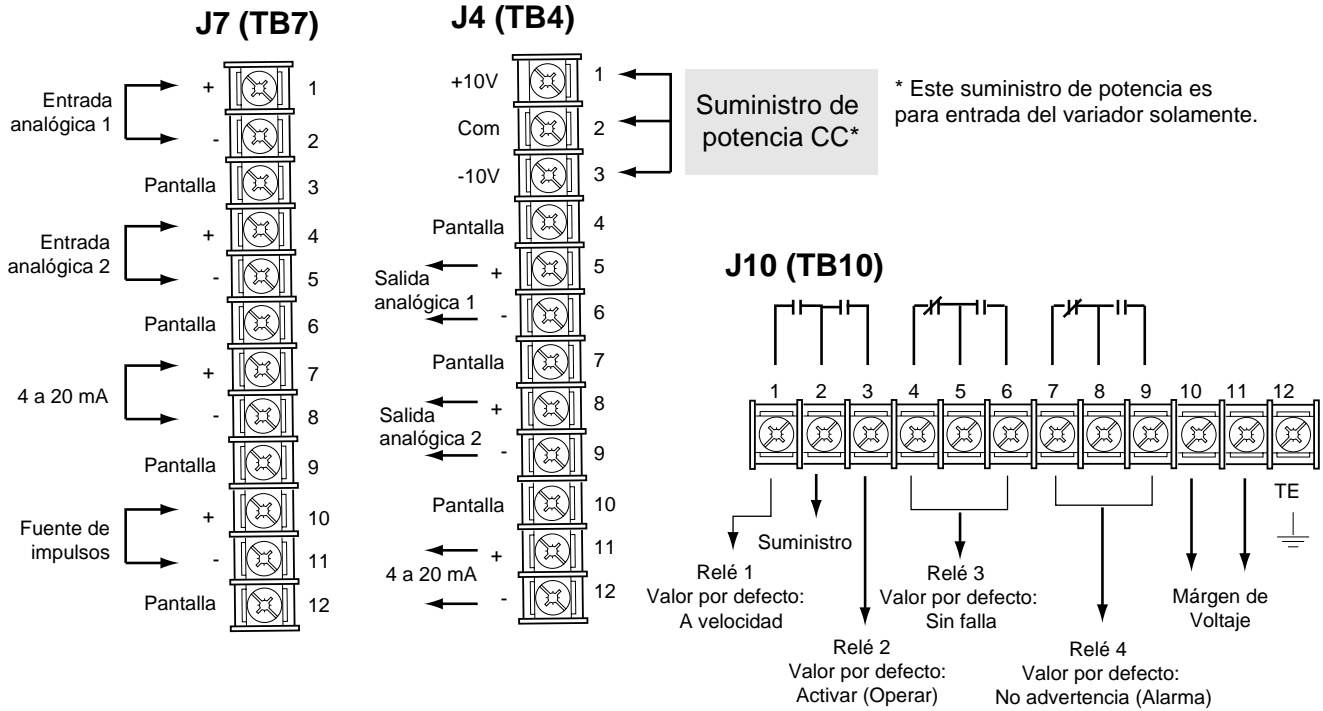

## Cableado E/S – Demás bastidores

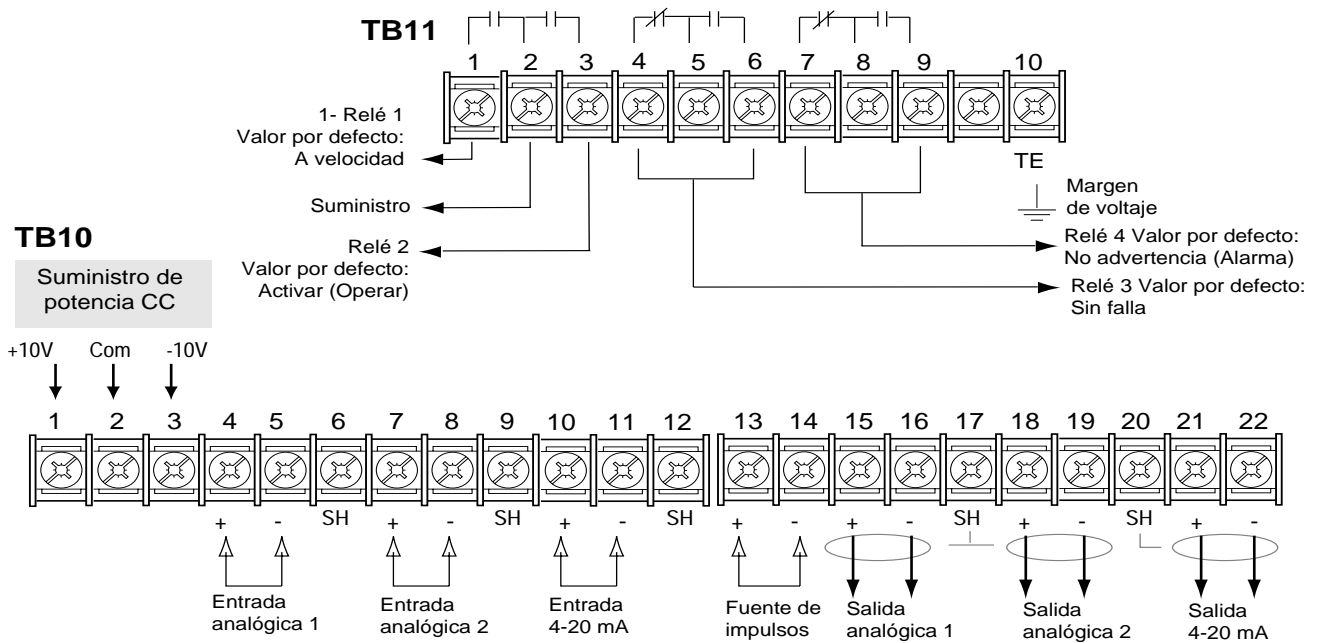

## Tarjeta Opción L

1	Estatus	Det./Elim. Falla	Estatus	Estatus	Estatus	Estatus	Estatus	Estatus	Activar
2	Arranque	Det./Elim. Falla	Reversa/Avanzar	Avan. Impul.	Falla Externa	Sel. Veloc. 3	Sel. Veloc. 2	Sel. Veloc. 1	Activar
3	Arranque	Det./Elim. Falla	Reversa/Avanzar	Tipo Paro	Falla Externa	Sel. Veloc. 3	Sel. Veloc. 2	Sel. Veloc. 1	Activar
4	Arranque	Det./Elim. Falla	Reversa/Avanzar	Acel. 2*/1	Falla Externa	Desacel. 2*/1	Sel. Veloc. 2	Sel. Veloc. 1	Activar
5	Arranque	Det./Elim. Falla	Reversa/Avanzar	Aumentar MOP	Falla Externa	Disminuir MOP	Sel. Veloc. 2	Sel. Veloc. 1	Activar
6	Arranque	Det./Elim. Falla	Reversa/Avanzar	Avan. Impul.	Falla Externa	Loc./Rem.	Sel. Veloc. 2	Sel. Veloc. 1	Activar
7	Arranque	Det./Elim. Falla	Reversa	Avanzar	Falla Externa	Avan. Impul.	Sel. Veloc. 2	Sel. Veloc. 1	Activar
8	Arranque	Det./Elim. Falla	Reversa	Avanzar	Falla Externa	Sel. Veloc. 3	Sel. Veloc. 2	Sel. Veloc. 1	Activar
9	Arranque	Det./Elim. Falla	Aumentar MOP	Disminuir MOP	Falla Externa	Sel. Veloc. 3	Sel. Veloc. 2	Sel. Veloc. 1	Activar
10	Arranque	Det./Elim. Falla	Reversa	Avanzar	Falla Externa	Aumentar MOP	Disminuir MOP	Sel. Veloc. 1	Activar
11	Arranque	Det./Elim. Falla	Acel. 1	Acel. 2	Falla Externa	Desacel. 1	Desacel. 2	Sel. Veloc. 1	Activar
12	Ejec. Avanzar	Det./Elim. Falla	Ejec. Reversa	Loc./Rem.	Falla Externa	Sel. Veloc. 3	Sel. Veloc. 2	Sel. Veloc. 1	Activar
13	Ejec. Avanzar	Det./Elim. Falla	Ejec. Reversa	Tipo Paro	Falla Externa	Sel. Veloc. 3	Sel. Veloc. 2	Sel. Veloc. 1	Activar
14	Ejec. Avanzar	Det./Elim. Falla	Ejec. Reversa	Acel. 2*/1	Falla Externa	Desacel. 2*/1	Sel. Veloc. 2	Sel. Veloc. 1	Activar
15	Ejec. Avanzar	Det./Elim. Falla	Ejec. Reversa	Aumentar MOP	Falla Externa	Disminuir MOP	Sel. Veloc. 2	Sel. Veloc. 1	Activar
16	Ejec. Avanzar	Det./Elim. Falla	Ejec. Reversa	Loc./Rem.	Falla Externa	Tipo Paro	Sel. Veloc. 2	Sel. Veloc. 1	Activar
17	Arranque	Det./Elim. Falla	Reversa/Avanzar	Reg. Ajste. Pceso.	Falla Externa	Des. Rampa	Sel. Veloc. 2	Sel. Veloc. 1	Activar
18	Arranque	Det./Elim. Falla	Reversa/Avanzar	Activ. Flujo	Falla Externa	Restablecer	Sel. Veloc. 2	Sel. Veloc. 1	Activar
19	Arranque	Det./Elim. Falla	Veloc./Tors. 3	Veloc./Tors. 2	Falla Externa	Veloc./Tors. 1	Reg. Ajste. Pceso.	Sel. Veloc. 1	Activar
20	Arranque	Det./Elim. Falla	Veloc./Tors. 3	Veloc./Tors. 2	Falla Externa	Veloc./Tors. 1	Activ. Flujo	Sel. Veloc. 1	Activar
21	Arranque	Det./Elim. Falla	Reversa	Avanzar	Falla Externa	Des. Rampa	Restablecer	Sel. Veloc. 1	Activar
22	Arranque	Det./Elim. Falla	Veloc./Tors. 3	Veloc./Tors. 2	Falla Externa	Veloc./Tors. 1	Sel. Veloc. 2	Sel. Veloc. 1	Activar
23	Ejec. Avanzar	Det./Elim. Falla	Ejec. Reversa	Reg. Ajste. Pceso.	Falla Externa	Restablecer	Sel. Veloc. 2	Sel. Veloc. 1	Activar
24	Ejec. Avanzar	Det./Elim. Falla	Ejec. Reversa	Activ. Flujo	Falla Externa	Restablecer	Sel. Veloc. 2	Sel. Veloc. 1	Activar
25	Ejec. Avanzar	Det./Elim. Falla	Ejec. Reversa	Reg. Ajste. Pceso.	Falla Externa	Des. Rampa	Sel. Veloc. 2	Sel. Veloc. 1	Activar
26	Ejec. Avanzar	Det./Elim. Falla	Ejec. Reversa	Avan. Impul.	Falla Externa	Sel. Veloc. 3	Sel. Veloc. 2	Sel. Veloc. 1	Activar
27	Arranque	Det./Elim. Falla	Reversa/Avanzar	Aumentar MOP	Falla Externa	Disminuir MOP	Sel. Veloc. 2	Sel. Veloc. 1	Activar
28	Arranque	Det./Elim. Falla	Aumentar MOP	Disminuir MOP	Falla Externa	Sel. Veloc. 3	Sel. Veloc. 2	Sel. Veloc. 1	Activar
29	Arranque	Det./Elim. Falla	Reversa	Avanzar	Falla Externa	Aumentar MOP	Disminuir MOP	Sel. Veloc. 1	Activar
30	Ejec. Avanzar	Det./Elim. Falla	Ejec. Reversa	Aumentar MOP	Falla Externa	Disminuir MOP	Sel. Veloc. 2	Sel. Veloc. 1	Activar

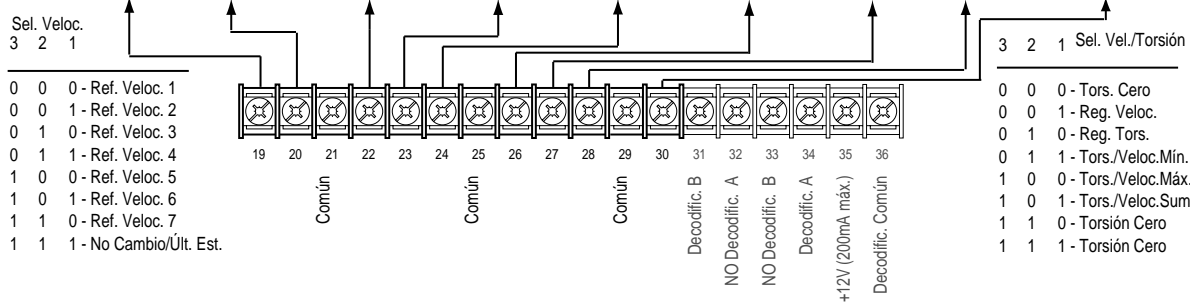

## Arranque

El siguiente procedimiento de arranque comprende únicamente los valores ajustados más comunes que emplean el modo “Startup” (Arranque) del 1336 IMPACT. Consulte el Manual del usuario para obtener información más detallada.

El siguiente procedimiento está dirigido a los usuarios que cuentan con un Módulo de Interfaz Humano (HIM, por sus siglas en inglés). Aquellos usuarios que no cuenten con un HIM deberán proporcionar señales y comandos externos. Se da por sentado que todos los parámetros mantienen los valores por defecto establecidos en fábrica.



**ATENCIÓN:** Para efectuar el siguiente procedimiento de arranque, se debe conectar la potencia al variador. Hay voltajes presentes al potencial de línea de entrada. Para evitar el peligro de descargas eléctricas o daño al equipo, el siguiente procedimiento deberá ser realizado sólo por personal de servicio calificado. Antes de comenzar, lea y entienda bien el procedimiento. Si se presenta alguna falla al realizar este procedimiento, No Prosiga. Desconecte la potencia abriendo el dispositivo de desconexión del bus de derivación y corrija el funcionamiento defectuoso antes de continuar.



**ATENCIÓN:** Para evitar el peligro de descargas eléctricas al realizar el cableado o darle servicio al variador, verifique que se haya descargado el voltaje de los capacitores del bus de CC. Mida el voltaje del bus de CC en los terminales + y – del bloque de terminales de alimentación TB1. El voltaje deberá ser cero.

1. Verifique que la línea y el control de potencia de CA coincidan con el valor nominal del variador.
2. Si se instala una Opción L, verifique que las entradas de enclavamiento “Stop” (Detener) y “Enable” (Activar) se encuentren presentes. Si no se instala esta opción, verifique que los puentes conectores se hallen instalados en las clavijas 3, 4, 17 y 18 en J5 en los variadores de bastidores A o en J2, en los variadores de bastidores B y superiores. Consulte el diagrama de ubicación de los puentes conectores.
3. Si se utiliza una E/S estándar, verifique que los puentes conectores se encuentren debidamente cableados.
4. Si se instala una Opción analógica, verifique que los parámetros hayan sido debidamente configurados (consulte el Manual del usuario).



**ATENCIÓN:** En todos los pasos a continuación puede producirse un giro del motor. Para protegerse contra lesiones, giro incorrecto y posibles daños al equipo, lea cada uno de los pasos detenidamente y llévelos a cabo con precaución.

5. Aplique potencia de CA y voltajes de control al variador. La pantalla LCD (pantalla de cristal líquido) deberá encenderse y mostrar el estatus de funcionamiento del variador “Stopped” (Detenido) y una frecuencia de salida de “+0,00 Hz”. Si el variador detecta una falla, la pantalla mostrará el informe correspondiente. Anote esta información, desconecte la potencia y corrija el origen de la falla antes de proceder.
6. Desde el “Status Display” (pantalla de estatus), oprima la tecla “Enter” (Ingresar) (o cualquier tecla). En la pantalla aparecerá “Choose Mode” (Seleccionar Modo). Oprima la tecla “Increment” (Incrementar) (o “Decrement” [Disminuir]) hasta que aparezca “Startup” (Arranque). Oprima “Enter”.

**Importante:** Todas las preguntas pueden responderse contestando Sí o No. Si oprime la tecla “Enter”, seleccionará el valor por defecto (“Y” o “N”). Si oprime la tecla “Increment” (o “Decrement”), podrá cambiar la selección. Oprima “Enter” para seleccionar. Si elige “Y” podrá continuar a través de todo el paso; si elige “N”, avanzará al próximo paso. La figura a continuación muestra los pasos comprendidos.

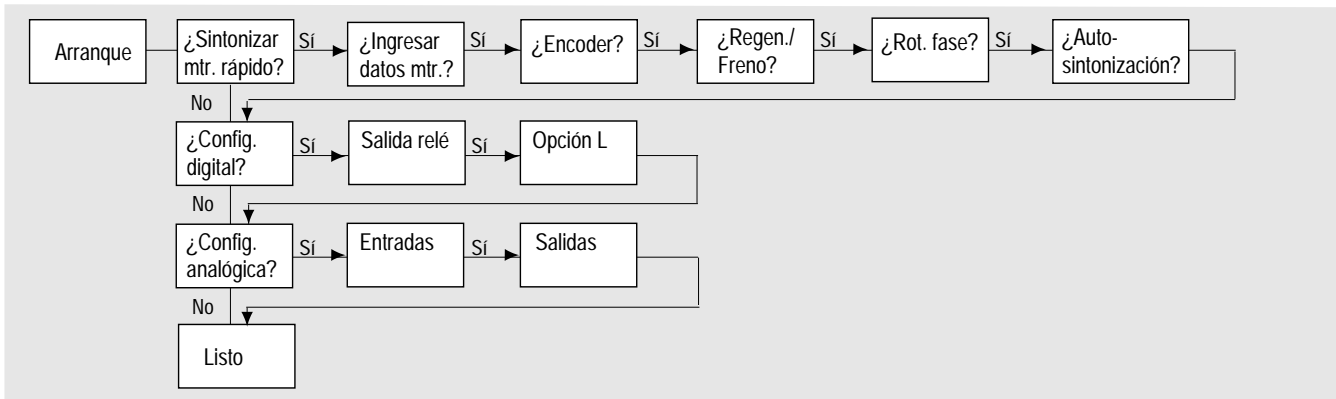

**Importante:** Observe lo siguiente:

- Se puede salir del modo “Startup” en cualquier momento oprimiendo la tecla ESCape hasta que aparezca la pantalla de estatus. Si desea volver a entrar al modo “Startup”, simplemente seleccione “Reset Sequence” (Restablecer secuencia) para comenzar desde el principio. Si selecciona “Continue” (Continuar) podrá proseguir desde el punto donde había concluido la operación.
  - Luego de completar la última acción avanzará automáticamente al próximo paso.
  - Al oprimir SElect activará la línea 2 de la pantalla. Esto deberá llevarse a cabo para todos los valores.
  - Oprima la tecla “Increment” (o “Decrement”) para ajustar un valor (salvo que el valor sea correcto). Oprima “Enter” para almacenar el valor o mantener el valor existente. Si oprime “Enter” nuevamente avanzará al próximo paso (parámetro).
7. Desconecte y conecte de nuevo la potencia para activar los cambios. Esto da por terminado el procedimiento de “Assisted Startup” (Arranque suplementario). Dependiendo de su aplicación, se necesitará programar parámetros adicionales y/o el “Advanced Startup” (Arranque avanzado). Consulte el Manual del usuario para mayores detalles.

## Dimensiones del variador

Para determinar el tamaño de su variador, consulte la siguiente tabla e ilustración.

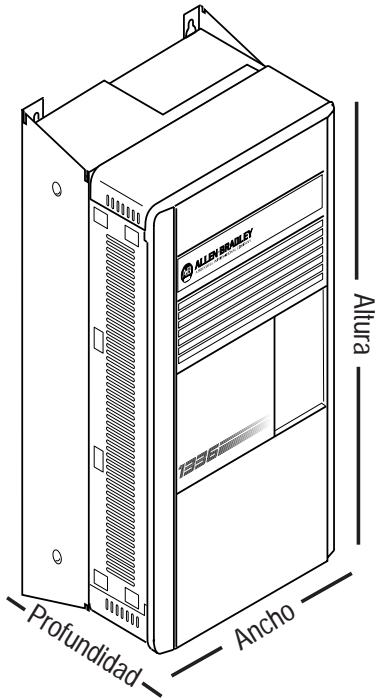

Bastidor	Ancho x Altura x Profundidad Milímetros (pulgadas)
A1	215,9 (8,50) x 290,0 (11,42) x 160,0 (6,30)
A2	215,9 (8,50) x 290,0 (11,42) x 180,5 (7,10)
A3	215,9 (8,50) x 290,0 (11,42) x 207,0 (8,15)
A4	260,0 (10,24) x 350,0 (13,78) x 212,0 (8,35)
B	276,4 (10,88) x 476,3 (18,75) x 225,0 (8,86)
C	301,8 (11,88) x 701,0 (27,60) x 225,0 (8,86)
D	381,5 (15,02) x 1240,0 (48,82) x 270,8 (10,66)
E-Cerrado	511,0 (20,12) x 1498,6 (59,00) x 477,5 (18,80)
E-Abierto	511,0 (20,12) x 1498,6 (59,00) x 372,6 (14,67)
F	762,0 (30,00) x 2286,0 (90,00) x 635,0 (25,00)
G	762,0 (30,00) x 2387,6 (94,0) x 635,0 (25,00)
H	1270,0 (50) x 2324,1 (91,50) <sup>①</sup> x 635,0 (25)

<sup>①</sup> Altura del ventilador (635,0 (25,00)) no incluido.

## Operación HIM

La programación o visualización de los parámetros se logra a través de los modos "Program" (Programar) o "Display" (Visualizar) que aparecen a continuación.



1. Desde la pantalla de estatus, oprima para visualizar "Choose Mode" (Seleccionar Modo).



2. Oprima o para visualizar "Program" (o "Display").

3. Oprima .



4. Oprima o hasta que aparezca en la pantalla el archivo deseado.

5. Oprima .



6. Oprima o hasta que aparezca en la pantalla el grupo deseado.

7. Oprima .

8. Oprima o para desplazarse hasta el parámetro deseado.

## Estructura del HIM

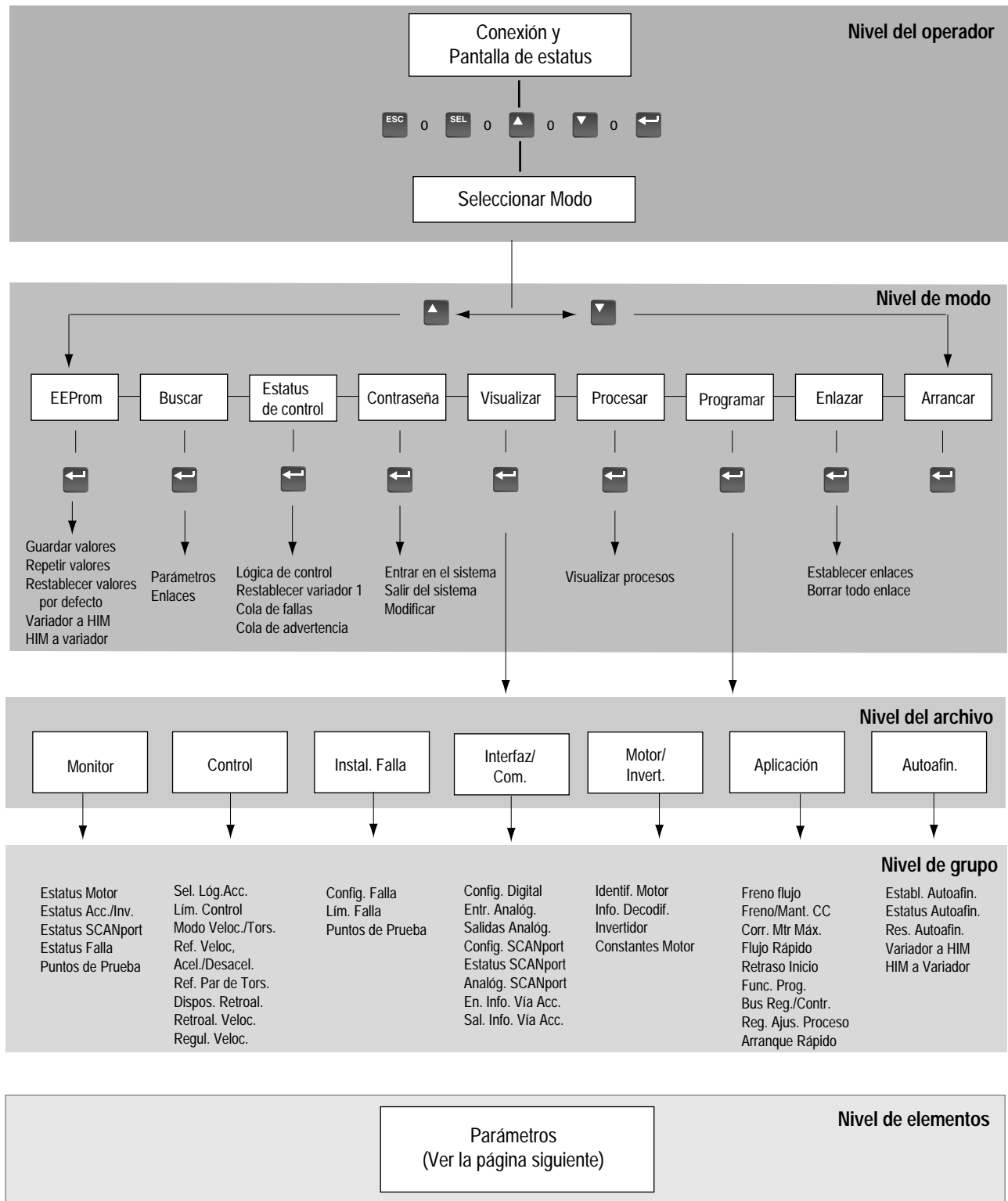

## Parámetros – Archivos, Grupos y Elementos

Nombre	No.	Valor Mín./Máx.	Nombre	No.	Valor Mín./Máx.
<b>Monitor</b>					
Estatus Motor			Lím. Cte. Neg. Mtr.	73	Cálc./0,0%
Veloc. Motor	81	-8 x BMS/+8 x BMS	Lím. Torsión. Pos.	74	0,0%/Cálc.
Frecuencia Motor	89	-250,000/+250,000 Hz	Lím. Torsión. Neg.	75	Cálc./0,0%
Corriente Motor	83	0,0/6553,5 amperios	Lím. Potenc. Regen.	76	-800,0%/0,0%
Volt. Motor	85	0/+3000 voltios	Lím. Coef. Cte.	77	Cálc./200,0%
% Voltaje Motor	234	0/800%	Corr. Máx. Mtr.	195	0/1
% Tors. Motor	86	-800,0/+800,0%	Lím. Veloc. Mín.	215	0,0/BMS rpm
% Flujo Motor	88	12,5/100,0%	Modo Veloc./Tors.		
% Potencia Motor	90	-800,0/+800,0%	Sel. Modo Vel./Tors.	68	0/5
Ret. Pos. Cerr. Baja	227	0/65535	Ref. Veloc.		
Ret. Pos. Cerr. Alta	228	0/65535	Ref. Veloc. 1	29	-8x/+8x BMS rpm
Ref. Tors. Int.	229	-800,0/+800,0%	Escala Veloc. 1	30	-3,9999/+3,9999
Estatus Variador/Inv.			Ref. Veloc. 2	31	-8x/+8x BMS rpm
Volt. Bus CC	84	0/1000 voltios	Ref. Veloc. 3	32	-8x/+8x BMS rpm
Espec. Oper. Lóg.	14	Selec. bit	Ref. Veloc. 4	33	-8x/+8x BMS rpm
Estatus Acc./Inv.	15	Selec. bit	Ref. Veloc. 5	34	-8x/+8x BMS rpm
Estatus Acc/Inv. 2	196	Selec. bit	Ref. Veloc. 6	35	-8x/+8x BMS rpm
Estatus. Inh. Ejec.	16	Selec. bit	Ref. Veloc. 7	36	-8x/+8x BMS rpm
Estatus. Veloc. Comndo.	82	-8 x BMS/+8 x BMS	Escala Veloc. 7	37	-3,9999/+3,9999
Estatus Lím. Tors.	87	Selec. bit	Veloc. Jog. 1	38	-8x/+8x BMS rpm
Salida Reg. Veloc.	225	-300,0/+300,0%	Veloc. Jog. 2	39	-8x/+8x BMS rpm
Error Veloc.	226	-8 x BMS/+8 x BMS	Acel./Desacel.		
Estatus SCANport			Tmpo. Acel. 1	42	0,0/6553,5 seg.
Ctl. Direc./Refer.	128	Selec. bit	Tmpo. Acel. 2	43	0,0/6553,5 seg.
Ctl. Inic./Deten.	129	Selec. bit	Tmpo. Desacel. 1	44	0,0/6553,5 seg.
Ctl. Acel.1/Acel.2	130	Selec. bit	Tmpo. Desacel. 2	45	0,0/6553,5 seg.
Ctl. Ramp./Elim. Fall.	131	Selec. bit	% Curva-S	47	0,0/100,0%
Ctl. Fljo./Reg. Ajste.	132	Selec. bit	Ref. Tors.		
Estatus Fallas			Ref. Tors.1	69	-800,0/+800,0%
Estatus Falla Conex.	219	Selec. bit	% Tors. Escl.	70	-200,00/+200,00%
Estatus Falla No Config.	220	Selec. bit	Disposit. Realim.		
Estatus Falla 1	221	Selec. bit	Tipo Disposit. Realim.	64	1/3
Estatus Falla 2	222	Selec. bit	Decodif. de PPR	8	Cálc./20000 ppr
Estatus Advertencia 1	223	Selec. bit	Realim. Veloc.		
Estatus Advertencia 2	224	Selec. bit	Realim. Vel. Esc.	63	-32767/+32767
Puntos de Prueba			Sel. Filtro Realim.	65	0/4
Info. Prueba 1	92	-32768/+32767	Inc. Filtro Realim.	66	-5,00/+5,00
Sel. Prueba 1	93	0/65535	aB. Filtro Realim.	67	0,2/900,0 rad./seg.
Info. Prueba 2	94	-32768/+32767	Frec. Fil. Muesca	185	5,0/135,0 Hz
Sel. Prueba 2	95	0/65535	Cal. Fil. Muesca	186	2/500
<b>Control</b>			Regul. Veloc.		
Sel. Accel. Lóg.			Inercia Total	157	0,01 seg./655,00 seg.
Opc. Lógicas	17	Selec. bit	aB. Bucle Veloc.	161	0,00 rad./seg./Cálc.
Tmpo. Retr. Detnr.	18	0,0/10,0 seg.	Ki Bucle Veloc.	158	0,0/4095,9
Tol. Veloc. Cero.	19	0,0 rpm/8x BMS rpm	Kp Bucle Veloc.	159	0,0/200,0
Veloc. Retr. Arrq.	193	-0,1/+0,1 x BMS	Kf Bucle Veloc.	160	0,500/1,000
Tmpo. Retr. Arrq.	194	0,0/10,0 seg.	aB. Filtr. Error	162	Cálc./1500,0 rad./seg.
Lím. Control			% Caída	46	0,0/25,5%
Límit. Veloc. Rev.	40	-6x BMS rpm/0,0 rpm	<b>Establ. Fallas</b>		
Límit. Veloc. Vc.	41	0,0 rpm/+6x BMS rpm	Config. Fallas		
Lím. Cte. Pos. Mtr.	72	0,0%/Cálc.	Selec. Falla 1	20	Selec. bit
			Selec. Advert. 1	21	Selec. bit

Nombre	No.	Valor Mín./Máx.	Nombre	No.	Valor Mín./Máx.
<b>Config. Fallas Cont.</b>			<b>Config. SCANport</b>		
Selec. Falla 2	22	Selec. bit	Activ. Cable SP2	181	Selec. bit
Selec. Advert. 2	23	Selec. bit	Activ. SP. Accion.	124	Selec. bit
<b>Límit. Fallas</b>			Direcc./Ref.	125	Selec. bit
Exceso Vel. Absol.	24	0,0 rpm/BMS rpm	Iniciar/Acelerar	126	Selec. bit
Tmpo. Ataque Mtr.	25	0,1/3276,7 seg.	El. Falla/Reac. Mtr.	127	Selec. bit
% Sobrecarga Mtr.	26	110,0/400,0%	<b>Estatus SCANport</b>		
Lín. Volt. Mín.	27	10,0/90,0%	Ctl. Direc./Ref.	128	Selec. bit
<b>Puntos de Prueba</b>			Ctl. Inic./Deten.	129	Selec. bit
Info. Prueba 1	92	-32768/+32768	Ctl. Acel. 1/Acel. 2	130	Selec. bit
Sel. Prueba 1	93	0/65535	Ctl. Ramp./Elim. Fall.	131	Selec. bit
Info. Prueba 2	94	-32768/+32767	Ctl. Fljo./Reg. Ajste.	132	Selec. bit
Sel. Prueba 2	95	0/65535	<b>SCANport Analógico</b>		
<b>Interfaz/Com.</b>			Sel. Sp. Ent. Anál. 1	133	1/16
<b>Config. Digital</b>			Val. Sp. Ent. Anál. 1	134	-32767/+32767
Config. Relé		0/38	Esc. Sp. Ent. Anál. 1	135	-1,000/+1,000
Config. Relé 1	115	-800,0/+800,0%	Sel. Sp. Ent. Anál. 2	136	1/16
Config. Relé 2	187	0/36	Val. Sp. Ent. Anál. 2	137	-32767/+32767
Parám. Relé 2	188	-800,0/+800,0	Esc. Sp. Anál. 2	138	-1,000/+1,000
Config. Relé 3	189	0/36	Sal. Sp. Anál.	139	-32767/+32767
Parám. Relé 3	190	-800,0/+800,0	<b>Info. Sal. In.</b>		
Config. Relé 4	191	0/36	Info. Entr. A1	140	-32767/+32767
Parám. Relé 4	192	-800/+800,0%	Info. Entr. A2	141	-32767/+32767
Modo Opción L	116	1/25	Info. Entr. B1	142	-32767/+32767
Conf. Entr. Opción L	117	Selec. bit	Info. Entr. B2	143	-32767/+32767
Incr. Oper. Man.	118	0,0/BMS	Info. Entr. C1	144	-32767/+32767
Valor Oper. Man.	119	0,0/BMSNA	Info. Entr. C2	145	-32767/+32767
Número de PPR	120	500/2000	Info. Entr. D1	146	-32767/+32767
Escala Pulso Entr.	121	0,01/10,00	Info. Entr. D2	147	-32767/+32767
Valor Pulso Entr.	122	-BMS/+BMS	<b>Info. Sal.</b>		
Valor Impulso	123	0,0/+8xBMS	Info. Sal. A1	148	-32767/+32767
<b>Entradas Analógicas</b>			Info. Sal. A2	149	-32767/+32767
Val. Anál. Entr. 1	96	-32767/+32767	Info. Sal. B1	150	-32767/+32767
Comp. Anál. Entr.1	97	-19,980/+19,980 voltios	Info. Sal. B2	151	-32767/+32767
Esc. Anál. Entr. 1	98	-16,000/+16,000	Info. Sal. C1	152	-32767/+32767
aB. Fil. Entr. Anál. 1	182	0,0/200,0 rad./seg.	Info. Sal. C2	153	-32767/+32767
Val. Anál. Entr. 2	99	-32767/+32767	Info. Sal. D1	154	-32767/+32767
Comp. Val. Anál. 2	100	-19,980/+19,980 voltios	Info. Sal. D2	155	-32767/+32767
Esc. Anál. Entr. 2	101	-16,000/+16,000			
aB. Filt. Ent. Anál. 2	183	0,0/200,0 rad./seg.			
Val. Entr. mA	102	-32767/+32767			
Comp. Entr. mA	103	-32,000/+32,000 mA			
Esc. Entr. mA	104	-16,00			
aB. Fil. Entr. mA	184	0,0/200,0 rad./seg.			
<b>Salidas Analóg.</b>					
Valor Anál. Sal. 1	105	-32767/+32767			
Comp. Anál. Sal. 1	106	-20,000/+20,000			
Esc. Anál. Sal. 1	107	-1,000/+1,000			
Val. Anál. Sal. 2	108	-32767/+32767			
Comp. Anál. Sal. 2	109	-19,980/+19,980 voltios			
Esc. Anál. Sal. 2	110	-1,000/+1,000			
Val. Salida mA	111	-32767/+32767			
Comp. Salida mA	112	-32,000/+32,000 mA			
Escala Sal. mA	113	-1,000/+1,000			

Nombre	No.	Valor Mín./Máx.	Nombre	No.	Valor Mín./Máx.
<b>Inversor motor</b>					
Identif. Motor			Sel. Func.	212	0/27
CF Nominal	2	0,2 cf/2000,0 cf	Salida Func. 1	213	Varía
R.P.M. Nominal	3	1 rpm/1500 rpm	Salida Func. 2	214	0/65535
Amperaje Nominal	4	0,1 amperios/Cálc.	Entr. Func. 9	232	-32767/+32767
Volt. Nominal	5	75 voltios/575 voltios	Entr. Func. 10	233	-32767/+32767
Hz Nominal	6	1,0/250,0 Hz	<b>Control Reg. Bus</b>		
Polos del Motor	7	2/40 polos	Opc. Bus/Freno	13	Selec. bit
Factor de Servic.	9	1,00/2,00	<b>Ajuste proceso</b>		
<b>Info. Decodif.</b>			Salida Reg. Ajste.	48	-800,0/+800,0%
Decodif. de PPR	8	Cálc./2000 ppr	Ref. Reg. Ajste.	49	-800,0/+800,0%
<b>Inversor</b>			Realim. Ajste.	50	-800,0/+800,0%
Frecuenc. PWM	10	1000 Hz/desde variador	Selec. Reg. Ajste.	51	Selec. bit
Amps. del Invert.	11	0,1 amps./desde variador	aB. Fil. Reg. Ajst.	52	0,0/240,0 rad./seg.
Volt. del In.	12	75/575 voltios	Pres. Sal. Reg. Ajst.	53	-800,0/+800,0%
<b>Constantes del Motor</b>			Inc. Itgrl. Reg. Ajst.	54	0,000/16,000
Resistenc. Estát.	166	0,00/100,00%	Inc. Prop. Reg. Ajst.	55	0,000/16,000
Inductanc. Pérd.	167	0,00/100,00%	Lím. Bjo. Reg. Ajst.	58	-800,0/+800,0%
Corriente. Flujo	168	0,00/75,00%	Lím. Alt. Reg. Ajst.	59	-800,0/+800,0%
Incr. Desliz.	169	0,0/400,0%	Ftr. Inc. Reg. Ajst.	60	-8,000/+8,000
Polos del Motor	7	2/40 polos	Mx. Rev. Vel. Ajst.	61	-6 x/0,0 BMS rpm
<b>Aplicación</b>			Mx. Vel. Avce. Ajst.	62	0,0 rpm/+6xBMS rpm
<b>Fren. flujo</b>			<b>Arranque rápido</b>		
Opc. Bus/Freno	13	Selec. bit	Selec. Arrnq. Ráp.	216	0/2
<b>CC fren./mant.</b>			Veloc. Arrq. Ráp.	217	P40/P41
Opc. Bus/Freno	13	Selec. bit	<b>Autoafinación</b>		
Corriente de frenado de CC	79	0,0%/Cálc.	Sel. Autoafin.		
Tiempo Frenado CC	80	0,0/6553,5 seg.	Sel. Autoafin./Diag.	173	Selec. bit
<b>400% Cte. Mtr.</b>			Config Diag. Trans.	172	Selec. bit
Corr. Máx. Mtr.	195	0/1	Tors. Autoafin.	164	250%/100,0%
<b>Flujo Rápido</b>			Veloc. Autoafin.	165	0,3 x BMS/BMS
Opc. Bus/Freno	13	Selec. bit	<b>Estatus Autoafin.</b>		
Nivel Flujo Rápido	78	100,0%/Cálc.	Estatus Autoafin.	156	Selec. bit
<b>Retr. Arranque</b>			Diag. Invert. 1	174	Selec. bit
Veloc. Retr. Arrq.	193	-0,1 x / +0,1 x BMS	Diag. Invert. 2	175	Selec. bit
Tmpo. Retr. Arrq.	194	0,0/10,0 seg.	Errores Autoafin.	176	Selec. bit
<b>Func. Prog.</b>			<b>Resultados Autoafin.</b>		
Entr. Func. 1	198	Varía	Resistenc. Estát.	166	0,00/100,00%
Másc./Val. Func. 1	199	Varía	Inductanc. Pérd.	167	0,00/100,00%
Sel. Eval. Func. 1	200	0/17	Corriente. Flujo	168	0,00/75,00%
Entr. Func. 2	201	Varía	Incr. Desliz.	169	0,0/400%
Másc./Val. Func. 2	202	Varía	Inercia Total	157	0,0/655,00 seg.
Sel. Eval. Func. 2	203	0/17	aB. Bucle Veloc.	161	0,00/Cálc. rad./seg.
Entr. Func. 3	204	Varía			
Másc./Val. Func. 3	205	Varía			
Sel. Eval. Func. 3	206	0/17			
Entr. Func. 4	207	Varía			
Entr. Func. 5	208	Varía			
Entr. Func. 6	209	Varía			
Entr. Func. 7	210	Varía			
Entr. Func. 8	211	Selec. bit			



Allen-Bradley, a Rockwell Automation Business, has been helping its customers improve productivity and quality for more than 90 years. We design, manufacture and support a broad range of automation products worldwide. They include logic processors, power and motion control devices, operator interfaces, sensors and a variety of software. Rockwell is one of the world's leading technology companies.

### Worldwide representation.



Argentina • Australia • Austria • Bahrain • Belgium • Brazil • Bulgaria • Canada • Chile • China, PRC • Colombia • Costa Rica • Croatia • Cyprus • Czech Republic • Denmark • Ecuador • Egypt • El Salvador • Finland • France • Germany • Greece • Guatemala • Honduras • Hong Kong • Hungary • Iceland • India • Indonesia • Ireland • Israel • Italy • Jamaica • Japan • Jordan • Korea • Kuwait • Lebanon • Malaysia • Mexico • Netherlands • New Zealand • Norway • Pakistan • Peru • Philippines • Poland • Portugal • Puerto Rico • Qatar • Romania • Russia-CIS • Saudi Arabia • Singapore • Slovakia • Slovenia • South Africa, Republic • Spain • Sweden • Switzerland • Taiwan • Thailand • Turkey • United Arab Emirates • United Kingdom • United States • Uruguay • Venezuela • Yugoslavia

Allen-Bradley Headquarters, 1201 South Second Street, Milwaukee, WI 53204 USA, Tel: (1) 414 382-2000 Fax: (1) 414 382-4444





Allen-Bradley, a Rockwell Automation Business, has been helping its customers improve productivity and quality for more than 90 years. We design, manufacture and support a broad range of automation products worldwide. They include logic processors, power and motion control devices, operator interfaces, sensors and a variety of software. Rockwell is one of the world's leading technology companies.

### Worldwide representation.



Argentina • Australia • Austria • Bahrain • Belgium • Brazil • Bulgaria • Canada • Chile • China, PRC • Colombia • Costa Rica • Croatia • Cyprus • Czech Republic • Denmark • Ecuador • Egypt • El Salvador • Finland • France • Germany • Greece • Guatemala • Honduras • Hong Kong • Hungary • Iceland • India • Indonesia • Ireland • Israel • Italy • Jamaica • Japan • Jordan • Korea • Kuwait • Lebanon • Malaysia • Mexico • Netherlands • New Zealand • Norway • Pakistan • Peru • Philippines • Poland • Portugal • Puerto Rico • Qatar • Romania • Russia-CIS • Saudi Arabia • Singapore • Slovakia • Slovenia • South Africa, Republic • Spain • Sweden • Switzerland • Taiwan • Thailand • Turkey • United Arab Emirates • United Kingdom • United States • Uruguay • Venezuela • Yugoslavia

Allen-Bradley Headquarters, 1201 South Second Street, Milwaukee, WI 53204 USA, Tel: (1) 414 382-2000 Fax: (1) 414 382-4444