



**Allen-Bradley**

1336 IMPACT™ AC DRIVE

**Precision  
Torque  
Control  
in an  
Easy-To-Use  
AC Drive.**



**1336 IMPACT**



**Rockwell  
Automation**

Bringing Together Leading Brands in Industrial Automation

## 1336 IMPACT AC Drive

### Stand-alone Torque Control

#### Product Highlights

- Force Technology™ for demanding speed and torque performance
- Patented current regulator provides true control of motor torque
- Simple Start-Up feature provides for fast commissioning and quick auto-tuning of speed and torque loops using motor nameplate data
- 16-step speed profiling feature for changing speed based on time, encoder counts or hardware inputs through the L-option card
- Encoderless Field-Oriented Control
- SCANport™ protocol provides common interface for programming devices
- Internal Process Trim Controller
- Common power platform of 1336 PLUS II and 1336 FORCE™ family of drives

#### Flexible, Yet Uncomplicated

The 1336 IMPACT drive is designed for simple set-up and operation but still provides the features of more complicated drives. The Quick Motor Tune procedure steps the operator through menus to load simple motor data, while the other required parameters are automatically loaded. This eliminates the need for complex motor parameter information. The configurable analog, digital I/O and various communication modules allow you to make your preferred communication choice.



## High Performance Speed and Torque Control

The 1336 IMPACT AC drive with Force Technology provides the precise motor speed and torque control necessary to handle some of the most demanding drive applications, including many that are typically reserved for DC drives. Force Technology, an Allen-Bradley patented Field-Oriented Control method, has a proven and unique ability to separate and independently control motor flux and torque allowing the 1336 IMPACT drive to deliver full torque down to zero speed. Force Technology, originally designed for customized drive systems, is now available in a compact, easy-to-use, stand-alone package.

Using the optional encoder interface, speed regulation is  $\pm 0.001\%$  of top speed over a 100:1 speed range with an operating speed range of 1000:1. Torque regulation of 2% is equal to some of our most powerful DC drives. Encoderless speed regulation of  $\pm 0.5\%$ , and up to a 120:1 speed range with torque regulation of 5%, help reduce the need for expensive motor-mounted encoders in many applications.

The 1336 IMPACT drive is also offered in a wide variety of pre-engineered and custom packages that exceed the standard product offering. Configured drives are available in IP20 (NEMA Type 1), IP54 (NEMA Type 12), and IP65 (NEMA Type 4) packaging. Custom drives are available in all drive ratings and packaging styles for your requirements.

## Member of the 1336 Family

The 1336 IMPACT AC drive shares many features with the 1336 PLUS II and 1336 FORCE AC drive family, including a common power structure, communications interface, and the Allen-Bradley line of communication modules. The power structure uses the latest IGBT technology to provide smooth performance and quiet operation. The 1336 IMPACT drive connects to a wide variety of networks, utilizing the same communication modules as many other Allen-Bradley drives. In addition, the Human Interface Module (HIM), DriveTools32™ and DriveExecutive™ software can be used to interface to the 1336 IMPACT drives.

## 1336 IMPACT™ AC DRIVE PRODUCT DATA



table of contents

|                                                               |    |
|---------------------------------------------------------------|----|
| <b>Product Description</b> .....                              | 4  |
| <b>Specifications</b> .....                                   | 6  |
| <b>Function Description</b> .....                             | 9  |
| <br>                                                          |    |
| <b>1336 IMPACT AC Drive Pre-Installation</b> .....            | 14 |
| IP 20 (NEMA Type 1) Dimensions – Frame A1, A2, A3, A4 .....   | 15 |
| IP 20 (NEMA Type 1) Dimensions – Frames B, C and D .....      | 16 |
| IP 20 (NEMA Type 1) Dimensions – Frame E .....                | 17 |
| IP 20 (NEMA Type 1) Dimensions – Frame F .....                | 18 |
| Open Dimensions – Frame F “Roll-In” Chassis .....             | 19 |
| IP 20 (NEMA Type 1) Dimensions – Frame G .....                | 20 |
| IP 20 (NEMA Type 1) Dimensions – Frame H .....                | 21 |
| IP 20 (NEMA Type 1) Bottom View Dimensions – Frame A1-E ..... | 22 |
| Mounting Requirements .....                                   | 23 |
| Input Conditioning .....                                      | 23 |
| AC Supply Source .....                                        | 23 |
| Typical Component and Terminal Block Locations .....          | 24 |
| Input Fuses and Circuit Breakers .....                        | 25 |
| Power Wiring – TB1 .....                                      | 28 |
| Motor Cables .....                                            | 33 |
| Cable Termination .....                                       | 36 |
| Control Interface Wiring – TB3 .....                          | 37 |
| Control and Signal Wiring .....                               | 40 |
| Customer Supplied Enclosures .....                            | 42 |
| Derating Guidelines .....                                     | 43 |
| <br>                                                          |    |
| <b>1336 IMPACT AC Drive Selection Guide</b> .....             | 53 |
| Drive Codes and Enclosures .....                              | 54 |
| Factory Installed Kits .....                                  | 56 |
| Kits for Customer Installation .....                          | 56 |
| Control Interface Kits .....                                  | 56 |
| Gasket and Enclosure Kits .....                               | 56 |
| Language Group .....                                          | 57 |
| Dynamic Brake Kits .....                                      | 57 |
| Terminator Kits .....                                         | 57 |
| Communication Option Kits .....                               | 57 |
| Human Interface Module Kits .....                             | 58 |
| Lug Kits .....                                                | 59 |
| Common Mode Choke Kits .....                                  | 59 |
| Line Reactors and Isolation Transformers .....                | 59 |

# Product Description

## The 1336 IMPACT AC Drive

The 1336 IMPACT AC drive is the latest addition to the 1336 family and offers high performance control of an AC motor. Its precise speed and torque control make it ideal for controlling most demanding applications.

Combining patented field-oriented control, current regulated pulse width modulation (CRPWM), and microprocessors permits motor speed regulation within 0.001% and precise control of torque at all speeds.

The 1336 IMPACT AC drive shares many features with the 1336 PLUS II and 1336 FORCE™ AC drives, including human interface, space-saving packaging, and communications capabilities. The IGBT power structure technology provides smooth current output to the motor, reducing motor heating.

## Simplicity

The 1336 IMPACT drive provides the ultimate in simplicity. The Quick Motor Tune procedure helps set up basic drive parameters, verify motor and encoder (if used) lead connections, and run auto-tune tests.

The Human Interface Module (HIM) is fast to program, and easy to read and understand.

## Flexibility

Parameter linking gives you control over how information is used by the drive.

Digital Programming – All programming is done with parameters, displayed in text and engineering units.

Easy-to-use parameters are organized in groups for quick access to related functions.

## Performance

Field-oriented control provides accurate speed and torque control of an AC motor, with or without the use of a motor-mounted encoder.

Motor temperature compensation is accomplished without the need for costly motor sensors.

High performance velocity regulator maintains speed regulation of 0.001% over a 100:1 speed range (with optional encoder feedback) with an operating speed range of 1000:1. Encoderless operation can provide  $\pm 0.5\%$  speed regulation and up to 120:1 speed range.

Integral process trim regulator may eliminate the need for separate external dancer or load cell controllers.

## Features

### Programmable

- Dynamic Braking Values
- Electronic Motor Overload
- Separately Adjustable Accel/Decel Times
- Programmable Velocity Loop
- 1 External Torque Reference
- 7 External/Preset Speeds
- 2 Jog Speeds
- Speed Droop
- Auto Tuning Speed and Torque Loop
- Selectable Speed/Torque Modes
- Internal Process Trim Regulator
- Current, Torque and Power Limits
- Programmable Setpoints
- Function Blocks
  - Timer Delay
  - State Machine
  - Add/Subtract
  - Maximum/Minimum
  - Logical Add/Subtract
  - Logical Multiply/Divide
  - Up/Down
  - Multiply/Divide
  - Scale
  - Hysteresis
  - Band

### I/O Interface

- SCANport™ Peripheral Interface
- Qty-2, Analog Inputs, 0 to  $\pm 10V$  DC
- Analog Input, 4-20 mA
- Qty-2, Analog Outputs, 0 to  $\pm 10V$  DC
- Analog Output, 4-40 mA
- Pulse Train Input
- Discrete Outputs
  - 4 Programmable Outputs

### Diagnostics

- Detection and Trip:
  - Undervoltage
  - Overvoltage
  - Drive Overcurrent
  - Drive Overtemperature
  - External Signal
  - Drive Output Short
  - Ground Fault
- Motor Stall
- Electronic Motor Overload
- 32-Message Fault Buffer
- 32-Message Warning Buffer

## Packaging

**Small size** conserves expensive panel space.

**"Planar Construction"** eliminates most internal cables and connectors. Increases reliability.

**Laminar Bus Design** reduces internal inductance, thereby reducing snubber losses and improving IGBT performance.

**Common Human Interface Module** provides simplicity of programming and flexibility of operation.

**Thermal Dissipation Management** design and extensive infra-red testing minimizes hot spots to maximize reliability.

**NEMA and International standards** designed for acceptability throughout the world.

**Common AC/DC Bus** accommodates both stand-alone and common bus using standard Motor Control Center (MCC) vertical sections.

## Electrical

### IGBTs (Insulated Gate Bipolar Transistors)

- Quiet motor operation through programmable carrier frequency.
- Used on complete line – 0.37 – 597 kw (0.5-800 HP)
- Third Generation devices — Reduced switching and conduction losses.

**Isolated Power and Logic** minimizes noise to improve reliability and stable operation.

**Field-Oriented Control** provides high-performance speed and torque control of AC motor.

**Independent Certification** C-UL Certification for dual US and Canadian applications. Designed to meet IEC, VDE, CE and other international standards.

**DC Cooling Fan** on many ratings eliminates the need for a transformer and voltage tapping; accommodates global usage.

**Internal Logic Supply from DC Bus** does not require separate control power wiring, and improves ride-through capability.

**Communications** built-in SCANport™ interface provides ease of integration to a wide variety of peripheral devices.

# Specifications

## Control Specifications

### Current Torque Control

Indirect Self-Organized, Field-Oriented Control  
 Current-regulated, sine-coded PWM with programmable carrier frequency.

| HP         | Drive Rating | Carrier Range |
|------------|--------------|---------------|
| 7.5-30 HP  | 4 kHz        | 1-12 kHz      |
| 40-60 HP   | 4 kHz        | 1-12 kHz      |
| 75-125 HP  | 2 kHz        | 1-6 kHz       |
| 150-250 HP | 2 kHz        | 1-6 kHz       |
| 300-650 HP | 2 kHz        | 1-4 kHz       |
| 600-650 HP | 1.5 kHz      | 1-4 kHz       |
| 700-800 HP | 1 kHz        | 1-4 kHz       |

Refer to Derating Guidelines on **Pages 43 to 51**.

### Output Voltage Range

Three voltage ranges are available. Each voltage range is line dependent and can power a motor between the following voltages:  
 200 - 240V AC (line dependent)  
 380 - 480V AC (line dependent)  
 500 - 600V AC (line dependent)  
 If the voltage required for your application is not shown, contact Allen-Bradley for specific information.  
 Note: Due to internal voltage drops in the power structure and voltage margins required for regulation, the drive is unable to produce full output voltage at base speed. If full horsepower is required at or above base speed, an increase in current is required to produce rated horsepower. This effect will occur in all drives, but is usually only significant in F, G, and, especially, H frame drives since the voltage drop is proportional to source inductance and load current.

### Output Frequency Range

0 to 250 Hz.

### Speed Regulation:

With Encoder Feedback: 0.001% of Top Speed Over a 100:1 Speed Range, 1000 to 1 operating range.  
 Encoderless: 0.5% of Top Speed Over a 120:1 typical Speed Range.

### Accel/Decel

Independently programmable accel and decel times.  
 Program from 0 to 6553 seconds in 0.1 second increments.

### Intermittent Overload Capability

Constant Torque: 150% of Rated Drive Output for 1 minute.  
 (Not to exceed 150% of Rated Drive Output Limit.)

### Current Limit

Current Limit programmable to 400% of rated motor current. (May require oversized drive)  
 Independent Motoring and Regenerative Limits.

### Inverse Time Overload Capability

Class 20 protection with speed-sensitive response.  
 Adjustable from 0-200% of rated output current in 3 speed ranges — 2:1, 4:1 & 10:1.  
 UL Certified — Meets NEC Article 430.

## Electrical Specifications

### AC Input Specifications

Voltage Tolerance: -10% of Minimum, +10% of Maximum.  
 Frequency Tolerance: 48-62 Hz.  
 Number of Phases: 3 — 100% Drive Rating.  
 1 — 50% Drive Rating.

Refer to Derating Guidelines on **Pages 43 to 51**.

### Displacement Power Factor

0.37-597 kW (0.5 - 800 HP): 0.95

### Efficiency

97.5% at rated amps, nominal line volts.

### Maximum Short Circuit Current Rating



200,000 A rms symmetrical, 600 volts (when used with AC line fuses specified on **Page 32**).

## Load Specifications

### Requirements

A balanced 3-phase inductive motor load is typical. Drive power rating is based on a typical NEMA Design B, 4- or-6 pole motor. Other motor loads may require application assistance.

## Environmental Specifications

|                                                |                                                                                                                                                                                                                                                                                                                                         |
|------------------------------------------------|-----------------------------------------------------------------------------------------------------------------------------------------------------------------------------------------------------------------------------------------------------------------------------------------------------------------------------------------|
| <b>Altitude</b>                                | 1000 m (3300 ft) maximum without derating.<br>Refer to the Derating Guidelines on <b>Pages 43 to 51</b> .                                                                                                                                                                                                                               |
| <b>Ambient Operating Temperature</b>           | IP00, Open: Chassis — 0 to 50°C (32 to 122°F).<br>IP20, NEMA Type 1: 0 to 40°C (32 to 104°F).<br>IP65, Nema Type 4: 0 to 40°C (32 to 104°F)<br>Refer to Derating Guidelines on <b>Pages 43 to 51</b> .                                                                                                                                  |
| <b>Storage Temperature</b> (all constructions) | – 40 to 70°C (– 40 to 158°F).                                                                                                                                                                                                                                                                                                           |
| <b>Relative Humidity</b>                       | 5 to 95% non-condensing.                                                                                                                                                                                                                                                                                                                |
| <b>Shock</b>                                   | 15G peak for 11 ms duration (±1.0 ms).                                                                                                                                                                                                                                                                                                  |
| <b>Vibration</b>                               | 0.006 inches (0.152 mm) displacement, 1G peak.                                                                                                                                                                                                                                                                                          |
| <b>Agency Certification</b>                    | U.L. Listed                                                                                                                                                                                                                                                                                                                             |
|                                                | <br>Marked for all applicable directives <sup>1</sup><br>Emissions EN 55011 Class B<br>Immunity EN 50082-1<br>EN 50082-2<br>IEC 801-2, 3, 4 per EN 50082-1, 2<br> |

<sup>1</sup> Note: Installation guidelines called out in Appendix E of the 1336 IMPACT User Manual (publication 1336 IMPACT-5.0) must be adhered to.

## Protection Specifications

|                                     | 200-240V Drive                                  | 380-480V Drive | 500-600V Drive |
|-------------------------------------|-------------------------------------------------|----------------|----------------|
| <b>AC Input Overvoltage Trip</b>    | 285V AC                                         | 570V AC        | 690V AC        |
| <b>AC Input Undervoltage Trip</b>   | 138V AC                                         | 280V AC        | 343V AC        |
| <b>Bus Overvoltage Trip</b>         | 405V DC                                         | 810V DC        | 975V DC        |
| <b>Bus Undervoltage Trip</b>        | 200V DC                                         | 400V DC        | 498V DC        |
| <b>Heat Sink Thermistor</b>         | Monitored by microprocessor.                    |                |                |
| <b>Drive Overcurrent Trip</b>       | 200% of rated output current.                   |                |                |
| <b>Line Transients</b>              | Up to 6000 volts peak per IEEE C62.41-1991.     |                |                |
| <b>Control Logic Noise Immunity</b> | Showering arc transients up to 1500 volts peak. |                |                |
| <b>Power Ride-Through</b>           | 15 milliseconds at full load.                   |                |                |
| <b>Logic Control Ride-Through</b>   | 0.5 seconds minimum, 2 seconds typical.         |                |                |
| <b>Ground Fault Trip</b>            | Phase-to-Ground on Drive Output.                |                |                |
| <b>Short Circuit Trip</b>           | Phase-to-Phase on Drive Output.                 |                |                |

## Optional Encoder Inputs

Line Driver Encoder 5V DC or 8-15V DC Output  
 Minimum Current – 10 mA per channel  
 Quadrature  
 Maximum Input Frequency – 125 kHz

# Specifications

## Input/Output Ratings

Requirements

Shown below are 1336 IMPACT AC drive input and output current ratings grouped by drive voltage ratings <sup>1</sup>.

### 200-240V

| Cat. No. | Input kVA | Input Amps | Output kVA | Output Amps |
|----------|-----------|------------|------------|-------------|
| AQF05    | 1-1.2     | 2.8        | 0.92       | 2.3         |
| AQF07    | 1.2-1.5   | 3.5        | 1.20       | 3.0         |
| AQF10    | 1.9-2.2   | 5.4        | 1.79       | 4.5         |
| AQF15    | 2.5-3.0   | 7.3        | 2.39       | 6.0         |
| AQF20    | 3.4-4.0   | 9.7        | 3.19       | 8.0         |
| AQF30    | 5.0-5.9   | 14.3       | 4.78       | 12.0        |
| AQF50    | 7.4-8.9   | 21.3       | 7.17       | 18.0        |
| A007     | 10-12     | 28         | 11         | 27.2        |
| A010     | 12-14     | 35         | 14         | 33.7        |
| A015     | 17-20     | 49         | 19         | 48.2        |
| A020     | 23-28     | 67         | 26         | 64.5        |
| A025     | 25-30     | 73         | 31         | 78.2        |
| A030     | 27-30     | 79         | 32         | 80.0        |
| A040     | 43-51     | 123        | 48         | 120.3       |
| A050     | 53-64     | 154        | 60         | 149.2       |
| A060     | 60-72     | 174        | 72         | 180.4       |
| A075     | 82-99     | 238        | 96         | 240.0       |
| A100     | 100-120   | 289        | 116        | 291.4       |
| A125     | 112-135   | 325        | 130        | 327.4       |

### 380-480V

| Cat. No. | Input kVA | Input Amps | Output kVA | Output Amps |
|----------|-----------|------------|------------|-------------|
| BRF05    | 0.9-1.2   | 1.4        | 0.96       | 1.2         |
| BRF07    | 1.4-1.7   | 2.1        | 1.35       | 1.7         |
| BRF10    | 1.8-2.3   | 2.8        | 1.83       | 2.3         |
| BRF15    | 2.3-2.9   | 3.5        | 2.39       | 3.0         |
| BRF20    | 3.2-4.0   | 4.8        | 3.19       | 4.0         |
| BRF30    | 4.7-6.0   | 7.2        | 4.78       | 6.0         |
| BRF50    | 8-10      | 12         | 8.29       | 10.4        |
| BRF75    | 9-12      | 14         | 11.07      | 13.9        |
| BRF100   | 16-21     | 25         | 19.92      | 25          |
| B015     | 18-23     | 28         | 22         | 27.2        |
| B020     | 23-29     | 35         | 27         | 33.7        |
| B025     | 23-26     | 43         | 33         | 41.8        |
| B030     | 32-41     | 49         | 38         | 48.2        |
| BX040    | 40-50     | 62         | 47         | 58.7        |
| B040     | 41-52     | 63         | 52         | 64.5        |
| B050     | 48-60     | 75         | 61         | 78.2        |
| BX060    | 62        | 75         | 61         | 78.2        |
| B060     | 61-77     | 93         | 76         | 96.9        |
| B075     | 78-99     | 119        | 96         | 120.3       |
| B100     | 98-124    | 149        | 120        | 149.2       |
| B125     | 117-148   | 178        | 143        | 180.4       |
| BX150    | 148       | 178        | 143        | 180.4       |
| B150     | 157-198   | 238        | 191        | 240.0       |
| B200     | 191-241   | 290        | 233        | 291.4       |
| B250     | 212-268   | 322        | 259        | 327.4       |
| B300     | 265-335   | 403        | 324        | 406.4       |
| BP300    | 265-334   | 402        | 324        | 406.4       |
| BPR300   | 265-334   | 402        | 324        | 406.4       |
| B350     | 300-379   | 455        | 366        | 459.2       |
| BP350    | 300-378   | 455        | 366        | 459.2       |
| BPR350   | 300-378   | 455        | 366        | 459.2       |
| B400     | 330-416   | 501        | 402        | 505.1       |
| BP400    | 313-396   | 476        | 383        | 481.0       |
| BPR400   | 313-396   | 476        | 383        | 481.0       |
| B450     | 372-470   | 565        | 454        | 570.2       |
| BP450    | 346-437   | 526        | 424        | 531.7       |
| BPR450   | 346-437   | 526        | 424        | 531.7       |
| B500     | 391-494   | 594        | 477        | 599.2       |
| B600     | 439-555   | 668        | 537        | 673.4       |
| B700C    | 517-625   | 835        | 677        | 850         |
| B800C    | 647-817   | 965        | 783        | 983         |

### 500-600V

| Cat. No. | Input kVA | Input Amps | Output kVA | Output Amps |
|----------|-----------|------------|------------|-------------|
| CWF10    | 2.6-3.1   | 3.0        | 2.49       | 2.5         |
| CWF20    | 3.5-4.2   | 4.0        | 4.18       | 4.2         |
| CWF30    | 5.2-6.2   | 6.0        | 5.98       | 6.0         |
| CWF50    | 6.9-8.3   | 8          | 7.87       | 7.9         |
| CWF75    | 9-10      | 10         | 10         | 9.9         |
| CWF100   | 10-12     | 12         | 12         | 12.0        |
| C015     | 17-20     | 19         | 19         | 18.9        |
| C020     | 21-26     | 25         | 24         | 23.6        |
| C025     | 27-32     | 31         | 30         | 30.0        |
| C030     | 31-37     | 36         | 35         | 34.6        |
| C040     | 40-48     | 46         | 45         | 45.1        |
| C050     | 48-57     | 55         | 57         | 57.2        |
| C060     | 52-62     | 60         | 62         | 61.6        |
| C075     | 73-88     | 84         | 85         | 85.8        |
| C100     | 94-112    | 108        | 109        | 109.1       |
| C125     | 118-142   | 137        | 137        | 138.6       |
| C150     | 136-163   | 157        | 157        | 159.7       |
| C200     | 217-261   | 251        | 251        | 252.6       |
| C250     | 244-293   | 282        | 283        | 283.6       |
| C300     | 256-307   | 296        | 297        | 298.0       |
| CX300    | 256-307   | 295        | 297        | 298.0       |
| C350     | 304-364   | 351        | 352        | 353.6       |
| CP350    | 301-361   | 347        | 349        | 350         |
| CPR350   | 301-361   | 347        | 349        | 350         |
| C400     | 349-419   | 403        | 405        | 406.4       |
| CP400    | 343-412   | 397        | 398        | 400         |
| CPR400   | 343-412   | 397        | 398        | 400         |
| C450     | 394-473   | 455        | 457        | 459.2       |
| C500     | 434-520   | 501        | 503        | 505.1       |
| C600     | 514-617   | 594        | 597        | 599.2       |
| C650     | 578-694   | 668        | 671        | 673.4       |
| C700     | 616-739   | 756        | 767        | 770         |
| C800     | 639-767   | 786        | 797        | 800         |

<sup>1</sup> Drive ratings are at nominal values. Refer to drive Derating Guidelines on Pages 43 to 51.

## Serial Communications

|                             |                                                                                                                          |
|-----------------------------|--------------------------------------------------------------------------------------------------------------------------|
| <b>Peripheral Interface</b> | SCANport Protocol, up to 6 peripherals can be connected.                                                                 |
| <b>Remote I/O</b>           | Single drop remote I/O to Allen-Bradley PLC® and SLC 500™. Supports full block transfer and link mode discrete transfer. |
| <b>RS232/422/485</b>        | DFI Protocol — DH485 Protocol — Customer Specific Protocol.                                                              |
| <b>DeviceNet™</b>           | DeviceNet to SCANport module — Available for all drive ratings.                                                          |
| <b>Flex™ I/O</b>            | Flex I/O to SCANport module — Available for all drive ratings.                                                           |
| <b>SLC</b>                  | SLC to SCANport module — Available for all drive ratings.                                                                |
| <b>ControlNet™</b>          | ControlNet to SCANport Module — Available for all drive ratings.                                                         |

## Control Inputs

|                                                                      |                                                                                                                                                                                                                                                                                                                                                                                                                                                                                                                                                                                                                                                                                                                                                                                                                                                                                                                                                                                        |
|----------------------------------------------------------------------|----------------------------------------------------------------------------------------------------------------------------------------------------------------------------------------------------------------------------------------------------------------------------------------------------------------------------------------------------------------------------------------------------------------------------------------------------------------------------------------------------------------------------------------------------------------------------------------------------------------------------------------------------------------------------------------------------------------------------------------------------------------------------------------------------------------------------------------------------------------------------------------------------------------------------------------------------------------------------------------|
| <b>Option L4/L7E</b><br>Contact Closure Interface Board Requirements | <p>Circuits used with Option L4/L7E must be capable of operating at 10mA without signal degradation. Reed type input devices are recommended.</p> <p>The L4/L7E option is compatible with the following Allen-Bradley PLC modules:</p> <ul style="list-style-type: none"> <li>• 1771-OYL</li> <li>• 1771-OZL</li> </ul> <p>Note: Option L7E is the same as Option L4 but with encoder feedback terminals.</p>                                                                                                                                                                                                                                                                                                                                                                                                                                                                                                                                                                          |
| <b>Option L5/L8E</b><br>+24V AC/DC Interface Board Requirements      | <p>Circuits used with Option L5/L8E must be capable of operating with <b>high = true logic</b>. DC external circuits in the low state must generate a voltage of no more than 8V DC. Leakage current must be less than 1.5 mA into a 2.5k Ohm load.</p> <p>AC external circuits in the low state must generate a voltage of no more than 10V DC. Leakage current must be less than 2.5 mA into a 2.5k Ohm load.</p> <p>Both AC and DC external circuits in the high state must generate a voltage of +20 to +26 volts and source a current of approximately 10 mA for each input.</p> <p>The L5/L8E option is compatible with these Allen-Bradley PLC® modules:</p> <ul style="list-style-type: none"> <li>• 1771-OB</li> <li>• 1771-OQ</li> <li>• 1771-OZL</li> <li>• 1771-OBD</li> <li>• 1771-OQ16</li> <li>• 1771-OBB</li> <li>• 1771-OBN</li> <li>• 1771-OYL</li> <li>• 1771-OB16</li> </ul> <p>Note: Option L8E is the same as Option L5 but with encoder feedback terminals.</p> |
| <b>Option L6/L9E</b><br>115V AC Interface Board Requirements         | <p>Circuits used with Option L6/L9E must be capable of operating with <b>high = true logic</b>. In the low state, circuits must generate a voltage of no more than 30V AC. Leakage current must be less than 10 mA into a 6.5k Ohm load.</p> <p>In the high state, circuits must generate a voltage of 90-115V AC +/-10% and source a current of approximately 20 mA for each input.</p> <p>The L5/L9E option is compatible with these Allen-Bradley PLC modules:</p> <ul style="list-style-type: none"> <li>• 1771-OW</li> <li>• 1771-OA</li> <li>• 1771-OWN</li> <li>• 1771-OAD (Contact Factory for Recommended Series/Rev. Level)</li> </ul> <p>Note: Option L9E is the same as Option L6 but with encoder feedback terminals.</p>                                                                                                                                                                                                                                                 |

## Control Outputs

|                        |                                                                                               |
|------------------------|-----------------------------------------------------------------------------------------------|
| <b>Contact Outputs</b> | 115V AC, 30V DC – 8.0 Amp Resistive – 3.5 Amp Inductive.<br>(4) Programmable Contact Outputs. |
|------------------------|-----------------------------------------------------------------------------------------------|

# Function Description

## Analog Inputs

### Analog Input Specifications

4-20 mA, Differential  
Resolution: 12 bit, Signed  
Input Impedance: 130 Ohms

(2) 0 to  $\pm$  10V DC, Differential  
Resolution: 12 bit, Signed  
Input Impedance: 20k Ohms  
Digital scale and offset for each input, definable in firmware.

## Analog Outputs

### Analog Output Specifications

4-20 ma, Differential  
Resolution: 12 bit, Signed  
Output Impedance: 20 Ohms

(2) 0 to  $\pm$  10V DC Differential  
Resolution: 12 bit, Signed  
Output Current: 10 mA maximum per output  
Output Impedance: 100 Ohms  
Digital Scale and offset, definable in firmware.

## Pulse Reference Input

### Pulse Input Specifications

The pulse input signal must be an externally powered square wave pulse train.  
Differential, 5 or 12V logic level.  
Maximum frequency of 100 kHz.  
10 mA minimum.

## Simple Start-up

The 1336 IMPACT drive provides a menu driven start-up procedure that leads you through entering the motor nameplate information and running the auto-tune tests. It also sets up the digital I/O by helping you configure the relay output and L Option Card, and sets up the analog I/O by helping you create links between the I/O and references. When the start-up procedure is complete, the drive should be set to perform basic functions.

**Auto-Tuning – Speed.** The auto-tuning feature allows the drive to tune the speed loop to the connected load without the use of complicated formulas or procedures. The drive tests for motor inertia (motor disconnected from load), system inertia, and system friction. This information is then used to tune the speed loop.

**Auto-Tuning – Torque Loop.** The 1336 IMPACT AC drive tunes the torque loop to the motor without any special equipment or hard-to-find motor information. This unique feature allows the 1336 IMPACT drive to be used with most motors.

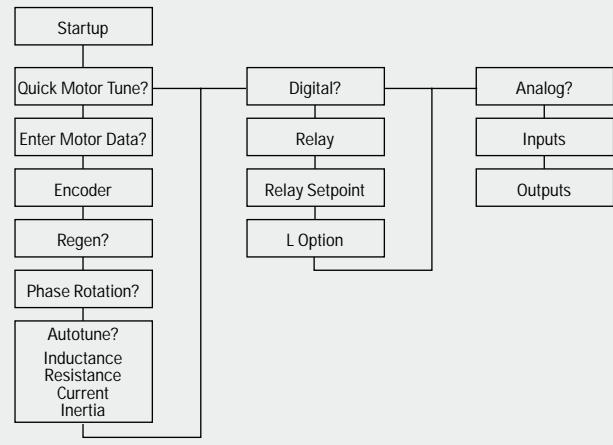

## Speed Control

The 1336 IMPACT AC drive provides precise speed control through the use of a high-bandwidth velocity regulator resulting in a speed regulation specification of 0.001% over a 100 to 1 speed range, when using an encoder and an operating speed range of 1000 to 1. Encoderless operation provides a speed regulation specification of 0.5% and up to 120 to 1 speed range.

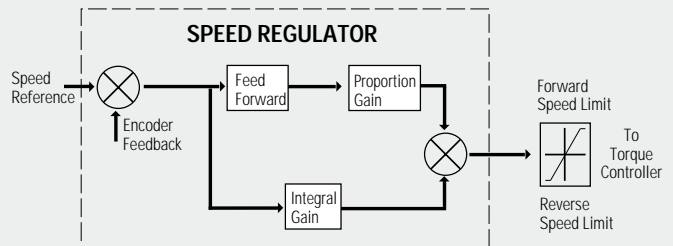

## Torque Control

Torque control is achieved through the use of Field-Oriented Control and current-regulated PWM (CRPWM). The user can program the drive for speed control, torque control, or combinations of both, depending on application. Adjustable torque, power, and current limits allow maximum flexibility for controlling demanding applications.

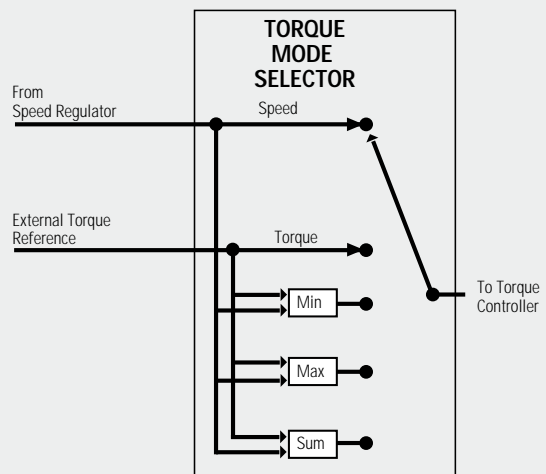

# Function Description

## Motor Temperature Compensation

As motor temperature changes, the torque output of the motor changes. Typically, a motor temperature sensor is placed in the motor and used by the drive to maintain better control of torque. The 1336 IMPACT AC drive automatically compensates for changing motor temperature without the need for a special, motor-mounted temperature sensor.

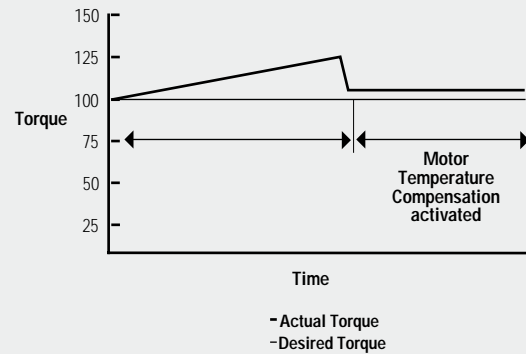

## Process Trim Controller

A process trim controller is built into the 1336 IMPACT AC drive. Transducers, such as dancers or load cells, can be connected directly to the drive and used to trim either the speed or torque output of the drive.

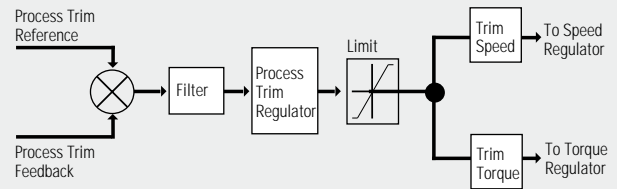

## Torque, Power, and Current Limits

Separate limit parameters provide maximum flexibility to control the motor torque output, power output, and total motor current. Each set of limits is independently programmable and has separate adjustments for motoring and regenerative regions.

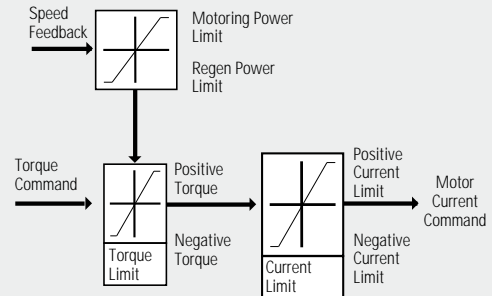

## Fault Diagnostics

The 1336 IMPACT AC drive has advanced fault diagnostic capabilities that enable the user to quickly diagnose and troubleshoot the drive. All faults are stored in non-volatile memory. Drive faults are categorized as either Trip- or Warning-type faults. When a fault occurs, a fault time stamp provides the relative time data.

**Trip faults** cause drive shutdown. A fault message is displayed on program terminals and fault status is also available to any device connected to or monitoring the drive. These faults are defined as either hard or soft faults.

**Warning faults** are indicated to devices connected to the drive but do not cause an immediate drive shutdown. This enables the user to take corrective action without unwanted nuisance shutdowns. Some warning faults can be programmed as Trip faults, or completely disabled.

A separate Trip fault buffer and Warning fault buffer store the last 32 messages that have occurred. These buffers are maintained in non-volatile memory. Separate clear fault and clear buffer capabilities are built-in.

### FAULT BUFFER

| FAULT CODE | FAULT MESSAGE            |
|------------|--------------------------|
| 1          | 02016 Overvoltage        |
| 2          | 02018 Ground Fault       |
| 3          | 03025 Absolute Overspeed |
| •          |                          |
| •          |                          |
| •          |                          |
| 32         |                          |

### WARNING BUFFER

| WARNING CODE | WARNING MESSAGE           |
|--------------|---------------------------|
| 1            | 01083 Motor Overload Pend |
| 2            | 05086 External Fault In   |
| 3            | 01085 Motor Stalled       |
| •            |                           |
| •            |                           |
| •            |                           |
| 32           |                           |

## Owners

The 1336 IMPACT AC drive displays which of the available SCANport ports currently “owns” certain control functions. To avoid conflict, some owners are exclusive (only one device can issue a reference), while others can have multiple control (many devices can simultaneously issue a start command). Owner displays are excellent diagnostic tools, displaying precisely where drive control commands originate.

|   |   |   |   |   |   |   |   |      |
|---|---|---|---|---|---|---|---|------|
| 7 | 6 | 5 | 4 | 3 | 2 | 1 | 0 | Port |
| 0 | 0 | 0 | 0 | 0 | 0 | 1 | 0 |      |

Indicates current speed command is issued from SCANport port 1 — Local Human Interface Module

Typical Owner Reference Source

## Masks

All external control connections to the 1336 IMPACT AC drive are made through a multi-connection communication bus called SCANport. With the possibility of many devices able to issue drive control functions (start, stop, reverse, speed reference, etc.), the 1336 IMPACT AC drive offers a mask for each control function that gives you complete flexibility to lock out any function (except stop) from any port.

|   |   |   |   |   |   |   |   |      |
|---|---|---|---|---|---|---|---|------|
| 7 | 6 | 5 | 4 | 3 | 2 | 1 | 0 | Port |
| 1 | 1 | 1 | 1 | 0 | 1 | 1 | 1 |      |

Allows jog from Adapter 1  
Denies jog from Adapter 3

Typical Jog Mask

## Braking Features

There are several choices for braking or decelerating the load with a 1336 IMPACT drive. These include an external Dynamic Brake, Brake Chopper kits or other regenerative method. When these are not present, the choices are Flux Braking, DC Braking or Bus Regulator. Select these options through firmware.

Flux Braking increases the motor flux current, which increases motor losses. The higher losses produce a shorter motor deceleration time.

DC Braking applies a DC current to the motor and becomes active only during a stop command. The amount of current applied is programmable and will affect the stopping time.

Bus Regulator is part of DC Bus Options and used to limit or control the bus voltage when decelerating or as regeneration occurs. At high bus voltage, the regulator becomes active and reduces the regenerative power limit to control bus voltage.

## DC Bus Options

DC bus options provide bus control and sensing adjustability for ride through on line loss. Without a brake, the DC bus regulator will help prevent bus over voltage trips by reducing the regenerative torque.

## Function Blocks

For applications requiring additional flexibility, the 1336 IMPACT drive has function blocks. This allows customizing of the drive operation by selecting one of eleven different functions. Functions available are a timer delay, state machine, add/subtract, maximum/minimum, up/down counter, multiply/divide, scale hysteresis, band, logical add/subtract, and logical multiply/divide block.

To use the state machine function block as an example, it defines a decision table. This table selects which value to use for the output, based on the values of the inputs.

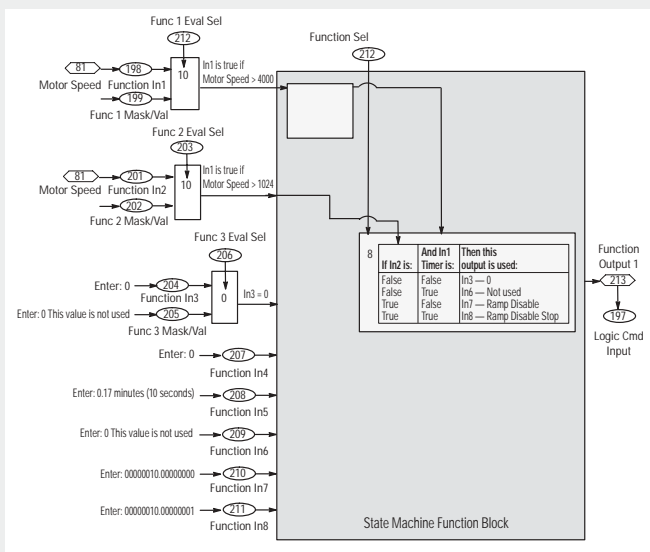

# 1336 IMPACT AC Drive Pre-Installation



**ATTENTION:** The following information is merely a guide for proper installation. The Allen-Bradley Company cannot assume responsibility for the compliance or the noncompliance to any code, national, local or otherwise for the proper installation of this drive or associated equipment. A hazard of personal injury and/or equipment exists if codes are ignored during installation.

## Frame Reference Guide

This Frame Reference Guide is referred to throughout this publication to provide a frame break reference for various options and drive ratings. Actual frame dimensions are given on the following (5) pages.

| 200-240V Drives            | 380-480V Drives             | 500-600V Drives            | Frame Designation |
|----------------------------|-----------------------------|----------------------------|-------------------|
| 0.37-0.75 kW<br>(0.5-1 HP) | 0.37-1.2 kW<br>(0.5-1.5 HP) | —<br>—                     | <b>A1</b>         |
| 1.2-1.5 kW<br>(1.5-2 HP)   | 1.5-2.2 kW<br>(2-3 HP)      | —<br>—                     | <b>A2</b>         |
| 2.2-3.7 kW<br>(3-5 HP)     | 3.7 kW<br>(5 HP)            | —<br>—                     | <b>A3</b>         |
| —<br>—                     | 5.5-7.5 kW<br>(7.5-10 HP)   | 0.75-3.7 kW<br>(1-10 HP)   | <b>A4</b>         |
| 5.5-11 kW<br>(7.5-15 HP)   | 11-22 kW<br>(15-30 HP)      | 11-15 kW<br>(15-20 HP)     | <b>B</b>          |
| 15-22 kW<br>(20-30 HP)     | 30-45 kW<br>(40-60 HP)      | 18.5-45 kW<br>(25-60 HP)   | <b>C</b>          |
| 30-45 kW<br>(40-60 HP)     | 45-112 kW<br>(60-150 HP)    | 56-93 kW<br>(75-125 HP)    | <b>D</b>          |
| 56-75 kW<br>(75-125 HP)    | 112-187 kW<br>(150-250 HP)  | 112-224 kW<br>(150-300 HP) | <b>E</b>          |
| —<br>—                     | 224-336 kW<br>(300-450 HP)  | 261-336 kW<br>(350-450 HP) | <b>F</b>          |
| —<br>—                     | 224-448 kW<br>(300-600 HP)  | 224-485 kW<br>(300-650 HP) | <b>G</b>          |
| —<br>—                     | 522-597 kW<br>(700-800 HP)  | 522-597 kW<br>(700-800 HP) | <b>H</b>          |

# 1336 IMPACT AC Drive Pre-Installation

## IP20 (NEMA Type 1) Dimensions — Frames A1, A2, A3 and A4

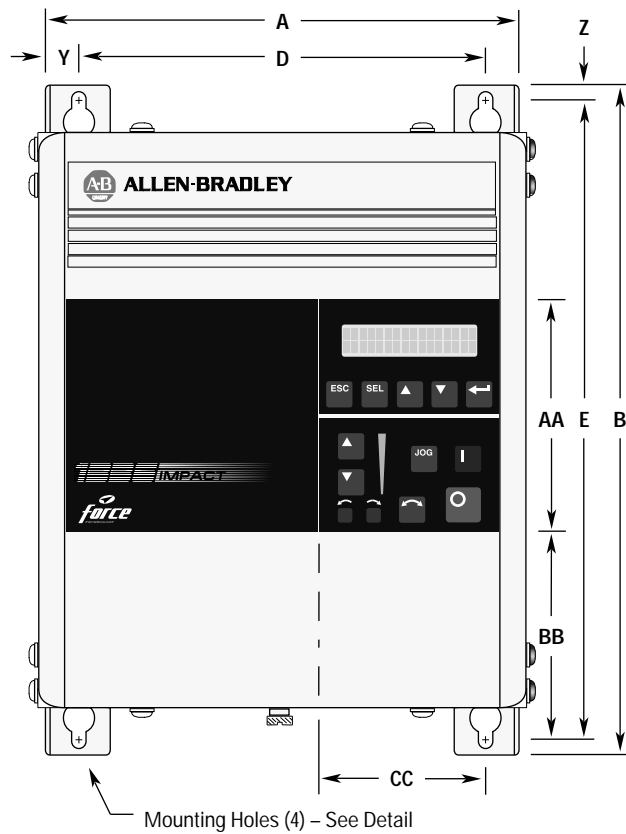

Mounting Hole Detail

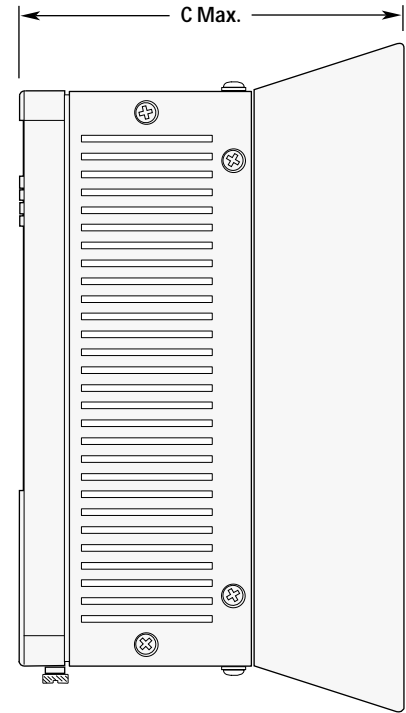
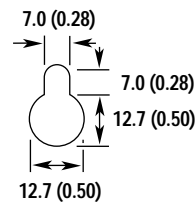

Bottom View Will Vary with HP - See Bottom View Dimensions

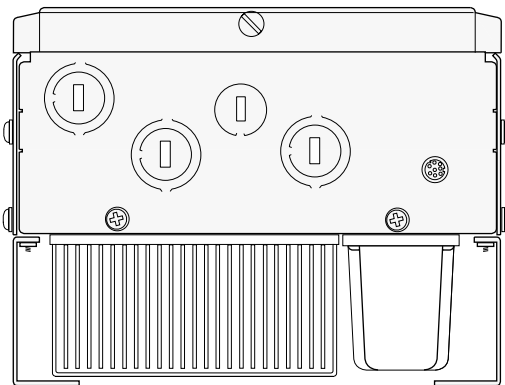

All Dimensions in Millimeters and (Inches)  
All Weights in Kilograms and (Pounds)

| Three-Phase Rating           | 200 – 240V                                | 380 – 480V                   | 500 – 600V | Frame Reference |
|------------------------------|-------------------------------------------|------------------------------|------------|-----------------|
| 0.37 – 0.75 kW<br>0.5 – 1 HP | 0.37 – 1.2 kW<br>0.5 – 1.5 HP             | —                            | —          | <b>A1</b>       |
| 1.2 – 1.5 kW<br>1.5 – 2 HP   | 1.5 – 2.2 kW<br>2 – 3 HP                  | —                            | —          | <b>A2</b>       |
| 2.2 – 3.7 kW<br>3 – 5 HP     | 3.7 kW<br>5 HP                            | —                            | —          | <b>A3</b>       |
| —                            | <b>5.5 – 7.5 kW</b><br><b>7.5 – 10 HP</b> | 0.75 – 7.5 kW<br>1 – 10 HP   | —          | <b>A4</b>       |
| 5.5 – 11 kW<br>7.5 – 15 HP   | <b>11 – 22 kW</b><br><b>15 – 30 HP</b>    | 11 – 15 kW<br>15 – 20 HP     | —          | <b>B</b>        |
| 15 – 22 kW<br>20 – 30 HP     | 30 – 45 kW<br>40 – 60 HP                  | 18.5 – 45 kW<br>25 – 60 HP   | —          | <b>C</b>        |
| 30 – 45 kW<br>40 – 60 HP     | 45 – 112 kW<br>60 – 150 HP                | 56 – 93 kW<br>75 – 125 HP    | —          | <b>D</b>        |
| 56 – 93 kW<br>75 – 125 HP    | 112 – 187 kW<br>150 – 250 HP              | 112 – 187 kW<br>150 – 250 HP | —          | <b>E</b>        |
| —                            | 224 – 336 kW<br>300 – 450 HP              | 261 – 336 kW<br>350 – 450 HP | —          | <b>F</b>        |
| —                            | 187 – 448 kW<br>300 – 600 HP              | 224 – 485 kW<br>300 – 650 HP | —          | <b>G</b>        |

Use care when choosing Frame Reference — some ratings may exist in another frame size.

| Frame Reference | A                | B                | C Max           | D               | E                | Y               | Z               | AA              | BB              | CC             | Shipping Weights       |
|-----------------|------------------|------------------|-----------------|-----------------|------------------|-----------------|-----------------|-----------------|-----------------|----------------|------------------------|
| <b>A1</b>       | 215.9<br>(8.50)  | 290.0<br>(11.42) | 160.0<br>(6.30) | 185.2<br>(7.29) | 275.0<br>(10.83) | 15.35<br>(0.60) | 7.5<br>(0.30)   | 130.0<br>(5.12) | 76.2<br>(3.00)  | 85.3<br>(3.36) | 4.31 kg<br>(9.5 lbs)   |
| <b>A2</b>       | 215.9<br>(8.50)  | 290.0<br>(11.42) | 180.5<br>(7.10) | 185.2<br>(7.29) | 275.0<br>(10.83) | 15.35<br>(0.60) | 7.5<br>(0.30)   | 130.0<br>(5.12) | 76.2<br>(3.00)  | 85.3<br>(3.36) | 5.49 kg<br>(12.1 lbs)  |
| <b>A3</b>       | 215.9<br>(8.50)  | 290.0<br>(11.42) | 207.0<br>(8.15) | 185.2<br>(7.29) | 275.0<br>(10.83) | 15.35<br>(0.60) | 7.5<br>(0.30)   | 130.0<br>(5.12) | 76.2<br>(3.00)  | 85.3<br>(3.36) | 6.71 kg<br>(14.8 lbs)  |
| <b>A4</b>       | 260.0<br>(10.24) | 350.0<br>(13.78) | 212.0<br>(8.35) | 230.0<br>(9.06) | 320.0<br>(12.60) | 15.35<br>(0.60) | 15.35<br>(0.60) | 130.0<br>(5.12) | 133.0<br>(5.23) | 86.0<br>(3.39) | 15.90 kg<br>(35.0 lbs) |

# 1336 IMPACT AC Drive Pre-Installation

## IP 20 (NEMA Type 1) Dimensions — Frames B, C and D

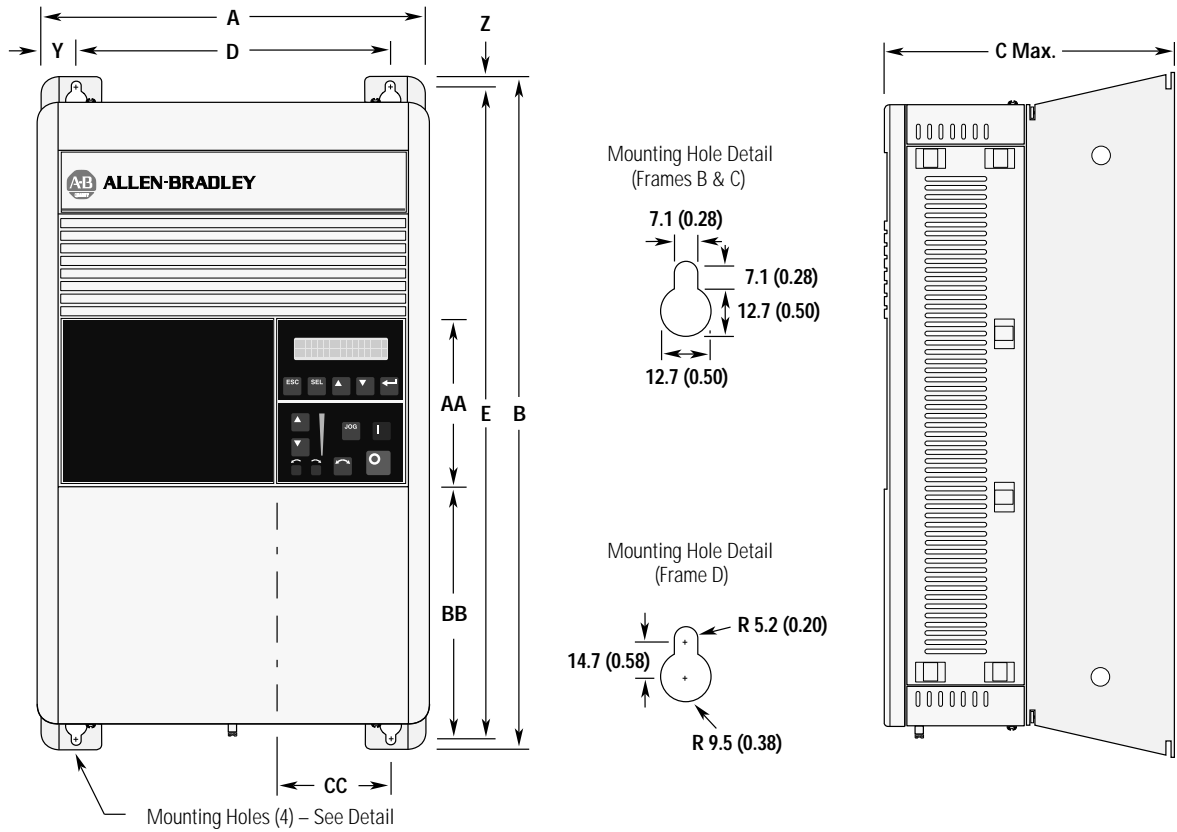

Bottom View Will Vary with HP – See Bottom View Dimensions

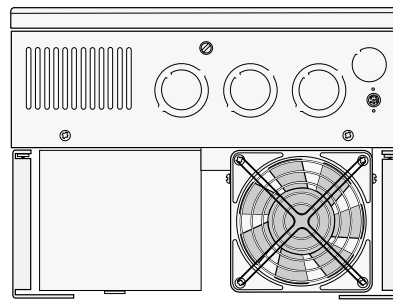

All Dimensions in Millimeters and (Inches)  
All Weights in Kilograms and (Pounds).

| Frame <sup>1</sup><br>Reference | A                | B                 | C Max.           | D                | E                 | Y               | Z               | AA              | BB               | CC             | Shipping<br>Weight    |
|---------------------------------|------------------|-------------------|------------------|------------------|-------------------|-----------------|-----------------|-----------------|------------------|----------------|-----------------------|
| B                               | 276.4<br>(10.88) | 476.3<br>(18.75)  | 225.0<br>(8.86)  | 212.6<br>(8.37)  | 461.0<br>(18.15)  | 32.00<br>(1.26) | 7.6<br>(0.30)   | 131.1<br>(5.16) | 180.8<br>(7.12)  | 71.9<br>(2.83) | 22.7 kg<br>(50 lbs)   |
| C                               | 301.8<br>(11.88) | 701.0<br>(27.60)  | 225.0<br>(8.86)  | 238.0<br>(9.37)  | 685.8<br>(27.00)  | 32.00<br>(1.26) | 7.6<br>(0.30)   | 131.1<br>(5.16) | 374.7<br>(14.75) | 71.9<br>(2.83) | 38.6 kg<br>(85 lbs)   |
| D                               | 381.5<br>(15.02) | 1240.0<br>(48.82) | 270.8<br>(10.66) | 325.9<br>(12.83) | 1216.2<br>(47.88) | 27.94<br>(1.10) | 11.94<br>(0.47) | 131.1<br>(5.16) | 688.6<br>(27.11) | 83.6<br>(3.29) | 108.9 kg<br>(240 lbs) |

<sup>1</sup> Refer to the Derating Guidelines on Pages 43 to 51 for derating information.

# 1336 IMPACT AC Drive Pre-Installation

## IP20 (NEMA Type 1) Dimensions — Frame E

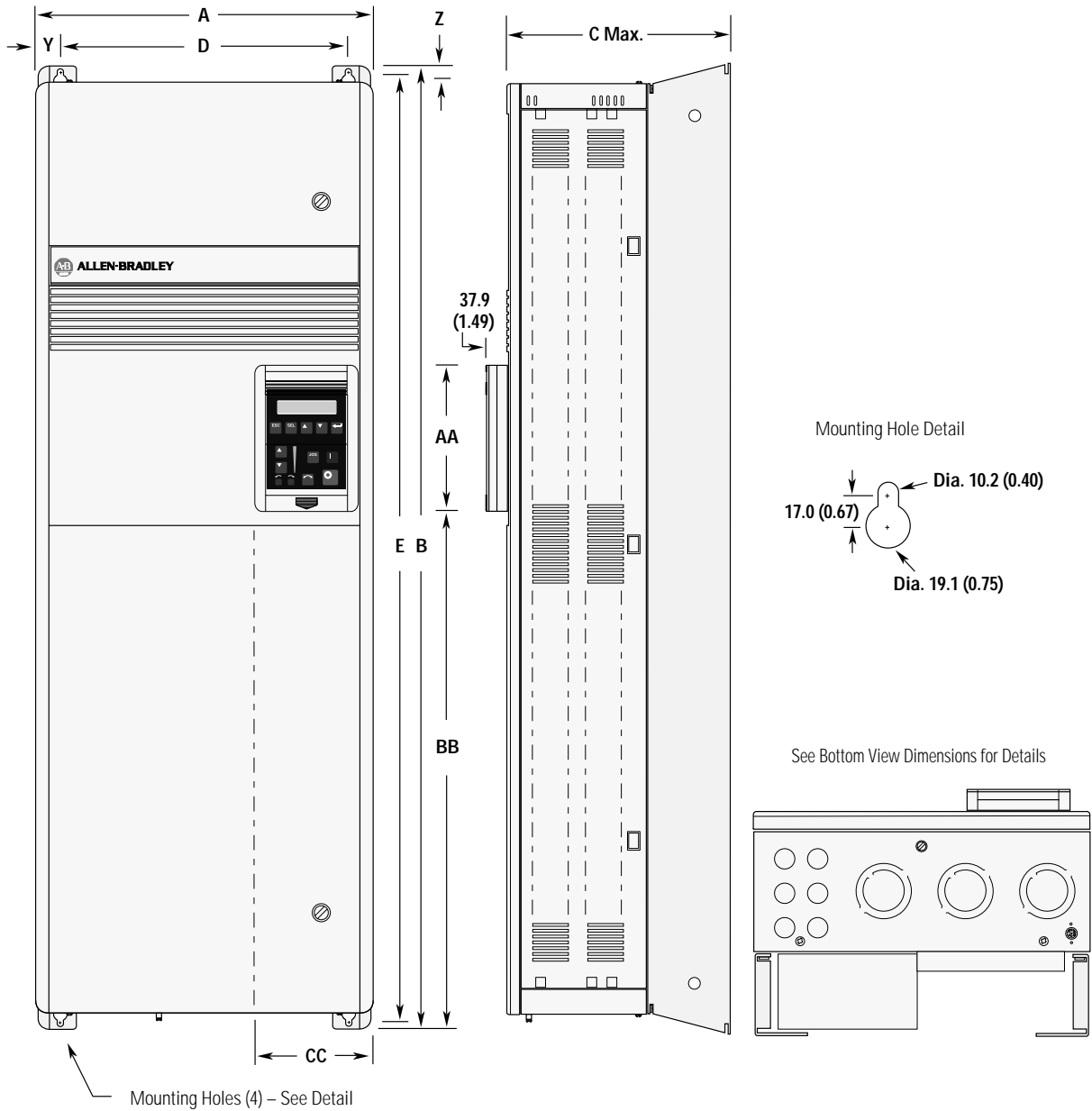

All Dimensions in Millimeters and (Inches).  
All Weights in Kilograms and (Pounds).

| Frame <sup>1</sup><br>Reference | A                | B                 | C Max.           | D                | E                 | Y              | Z              | AA              | BB               | CC              | Shipping<br>Weight  |
|---------------------------------|------------------|-------------------|------------------|------------------|-------------------|----------------|----------------|-----------------|------------------|-----------------|---------------------|
| E — Enclosed                    | 511.0<br>(20.12) | 1498.6<br>(59.00) | 424.4<br>(16.71) | 477.5<br>(18.80) | 1447.8<br>(57.00) | 16.8<br>(0.66) | 40.1<br>(1.61) | 195.0<br>(7.68) | 901.4<br>(35.49) | 151.9<br>(5.98) | 186 kg<br>(410 lbs) |
| E — Open                        | 511.0<br>(20.12) | 1498.6<br>(59.00) | 372.6<br>(14.67) | 477.5<br>(18.80) | 1447.8<br>(57.00) | 16.8<br>(0.66) | 40.1<br>(1.61) | 138.4<br>(5.45) | 680.0<br>(26.77) | 126.3<br>(4.97) | 163 kg<br>(360 lbs) |

<sup>1</sup> Refer to the Derating Guidelines on **Pages 43 to 51** for derating information.

# 1336 IMPACT AC Drive Pre-Installation

## IP 20 (NEMA Type 1) Dimensions — Frame F

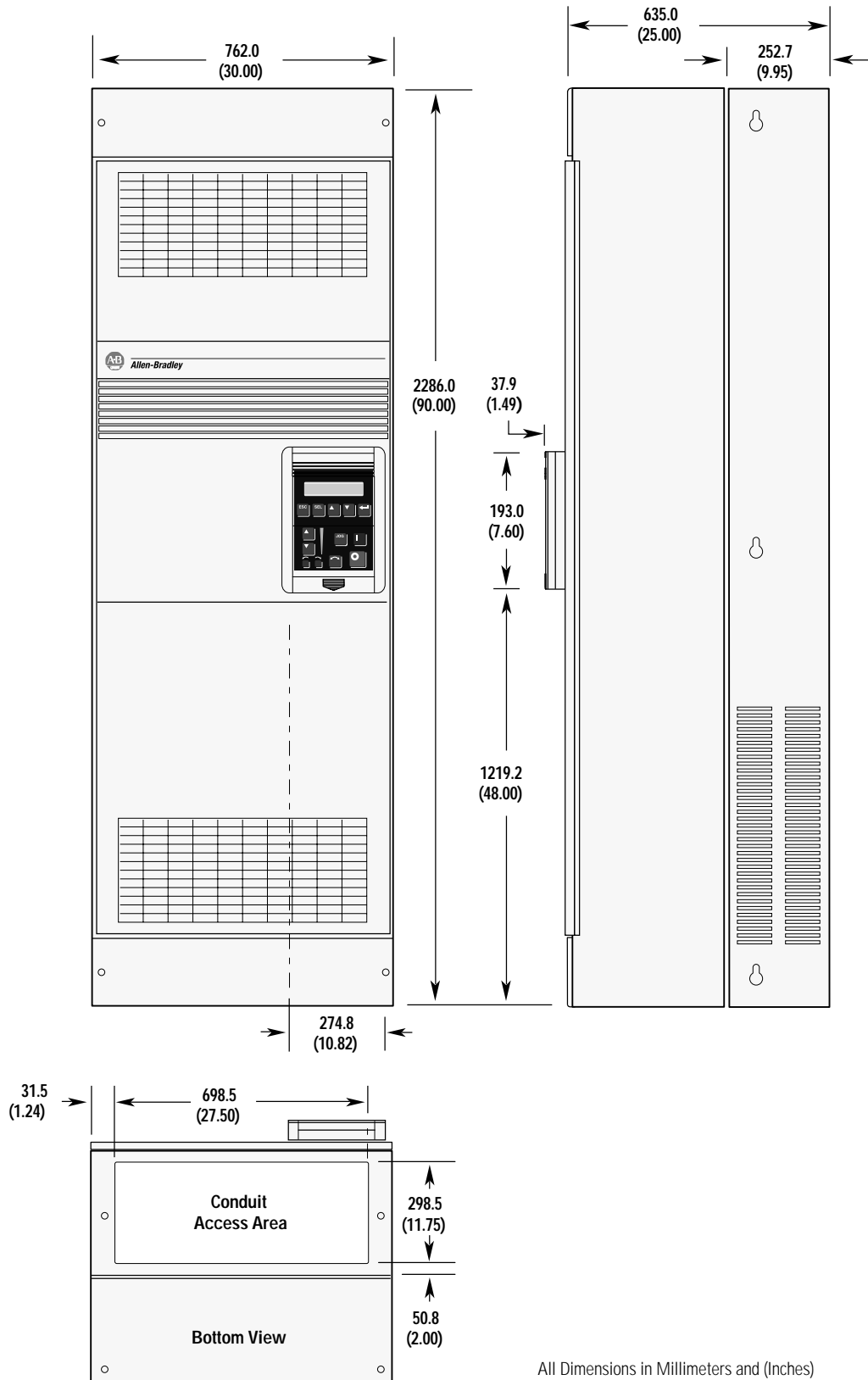

For Frame Reference refer to the Derating Guidelines on **Pages 43 to 51** for derating information.

# 1336 IMPACT AC Drive Pre-Installation

## Open Dimensions — Frame F "Roll-in" Chassis

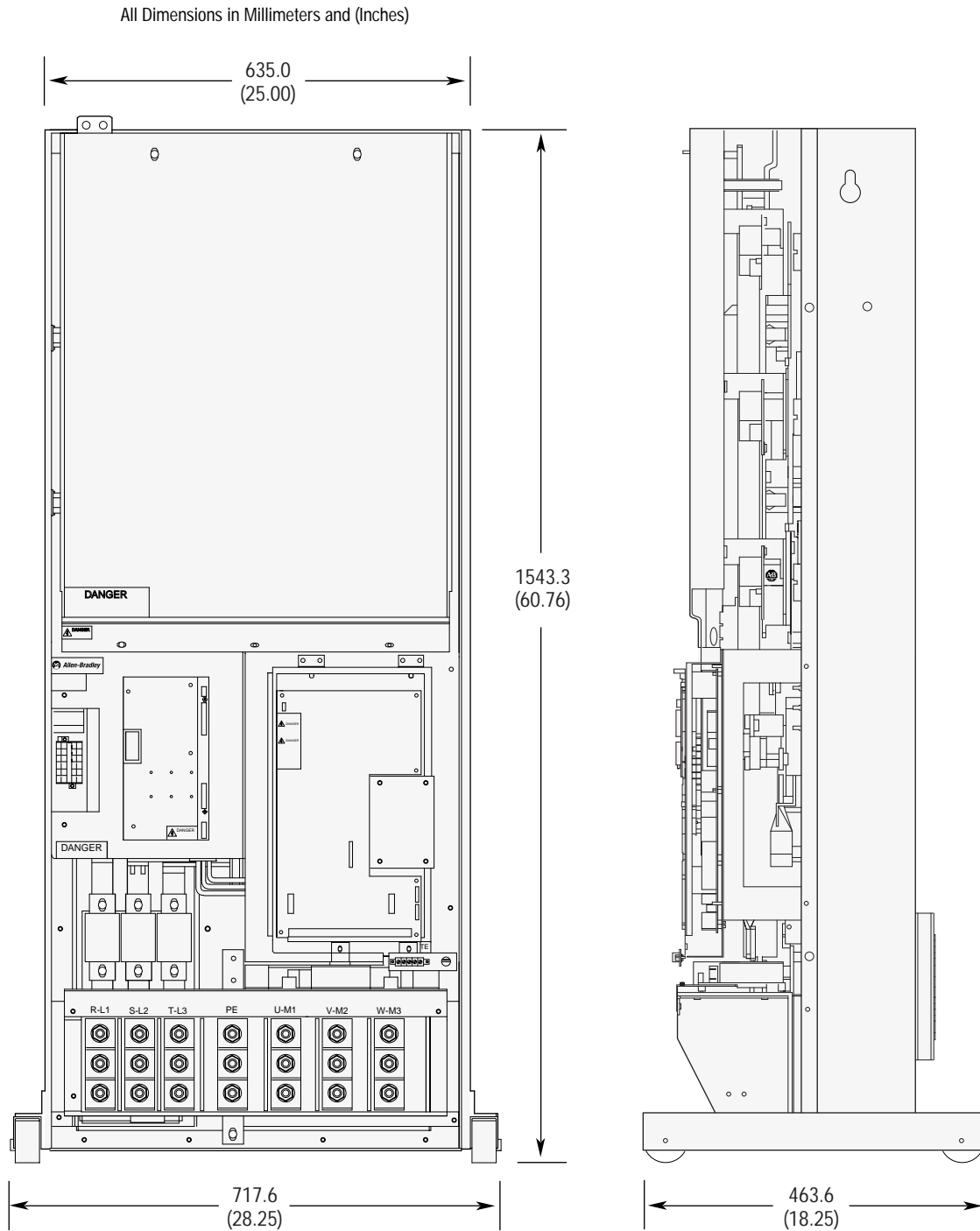

For Frame Reference refer to the Derating Guidelines on **Pages 43 to 51** for derating information.

# 1336 IMPACT AC Drive Pre-Installation

## IP 20 (NEMA Type 1) Dimensions — Frame G

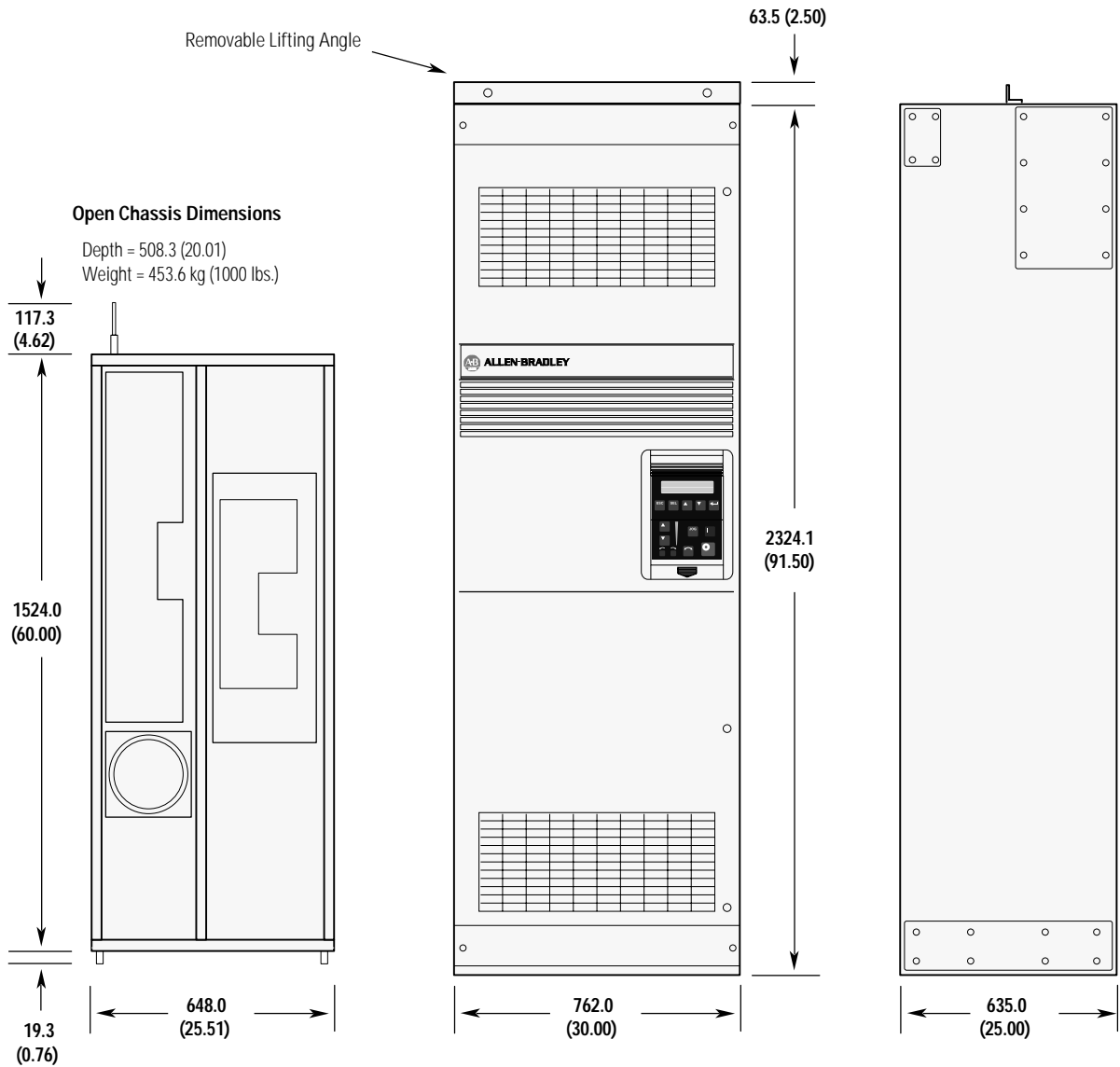

**Important:** Two (2) 725 CFM fans are required if an open type drive is mounted in a user supplied enclosure.

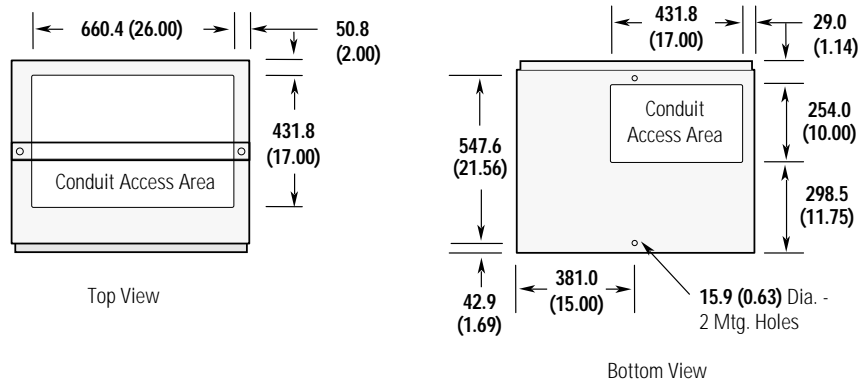

All Dimensions in Millimeters and (Inches)

For Frame Reference refer to the Derating Guidelines on **Pages 43 to 51** for derating information.

# 1336 IMPACT AC Drive Pre-Installation

## IP 20 (NEMA Type 1) Dimensions — Frame H

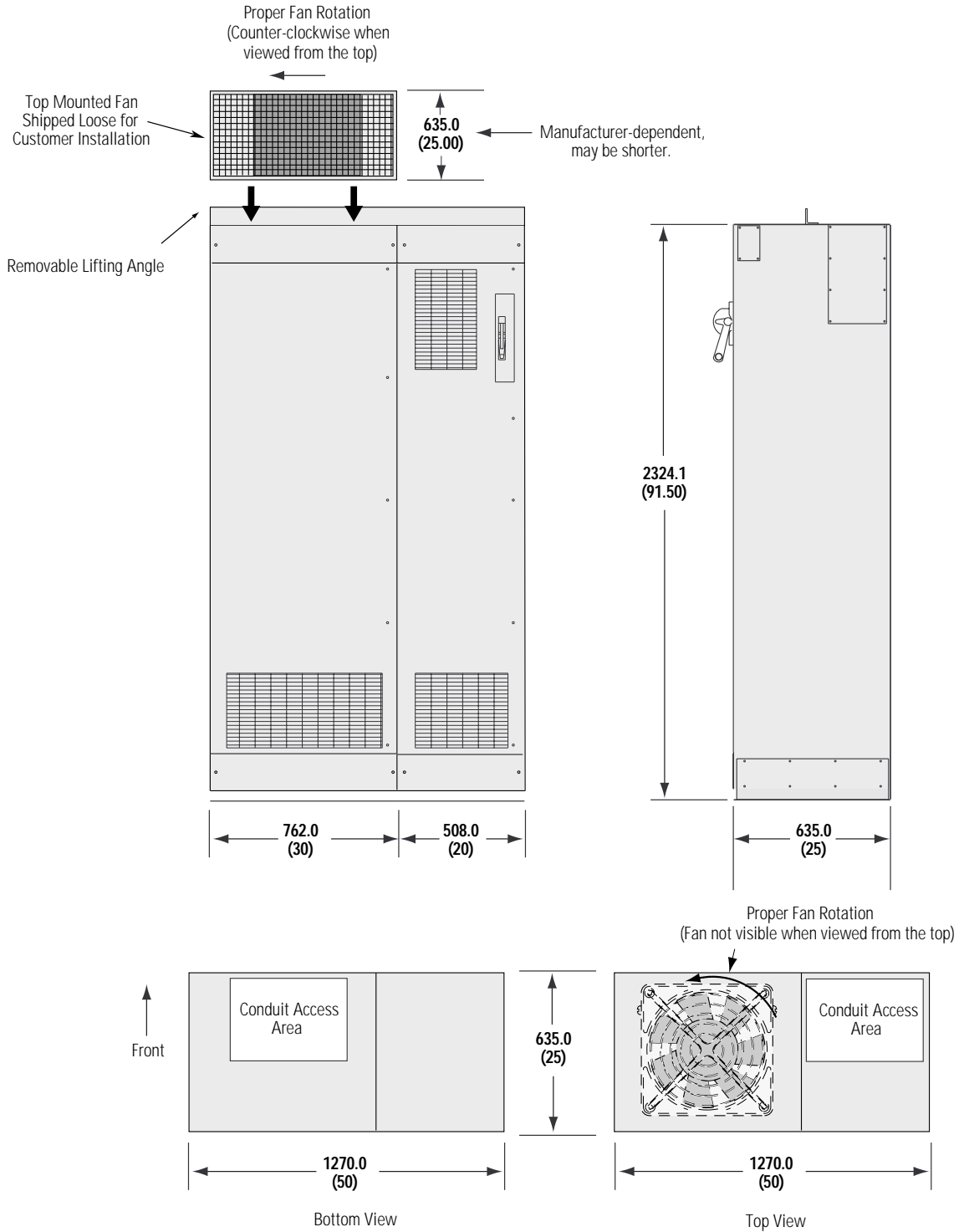

All Dimensions in Millimeters and (Inches)

For Frame Reference refer to the Derating Guidelines on **Pages 43 to 51** for derating information.

# 1336 IMPACT AC Drive Pre-Installation

## Bottom View Dimensions — Frames A1 - E

All Dimensions in Millimeters and (Inches).

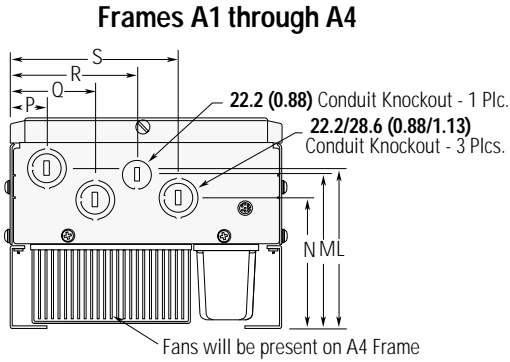

| Frame Reference | L               | M               | N               | P              | Q              | R               | S               |
|-----------------|-----------------|-----------------|-----------------|----------------|----------------|-----------------|-----------------|
| A1              | 111.8<br>(4.40) | 105.4<br>(4.15) | 86.3<br>(3.40)  | 25.4<br>(1.00) | 63.2<br>(2.49) | 102.1<br>(4.02) | 135.4<br>(5.33) |
| A2              | 132.3<br>(5.21) | 126.0<br>(4.96) | 106.9<br>(4.21) | 25.4<br>(1.00) | 63.2<br>(2.49) | 102.1<br>(4.02) | 135.4<br>(5.33) |
| A3              | 158.8<br>(6.25) | 152.4<br>(6.00) | 133.4<br>(5.25) | 25.4<br>(1.00) | 63.2<br>(2.49) | 102.1<br>(4.02) | 135.4<br>(5.33) |
| A4              | 164.0<br>(6.45) | 164.0<br>(6.45) | 139.0<br>(5.47) | 27.0<br>(1.06) | 65.0<br>(2.65) | 97.0<br>(3.82)  | 128.7<br>(5.07) |

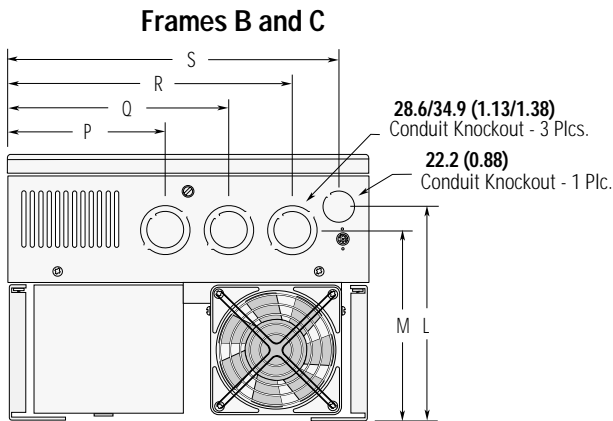

| Frame Reference | L               | M               | P               | Q               | R               | S                |
|-----------------|-----------------|-----------------|-----------------|-----------------|-----------------|------------------|
| B               | 181.6<br>(7.15) | 167.1<br>(6.58) | 112.8<br>(4.44) | 163.6<br>(6.44) | 214.4<br>(8.44) | 249.9<br>(9.84)  |
| C               | 181.6<br>(7.15) | 167.1<br>(6.58) | 119.1<br>(4.69) | 182.6<br>(7.19) | 227.1<br>(8.94) | 275.3<br>(10.84) |

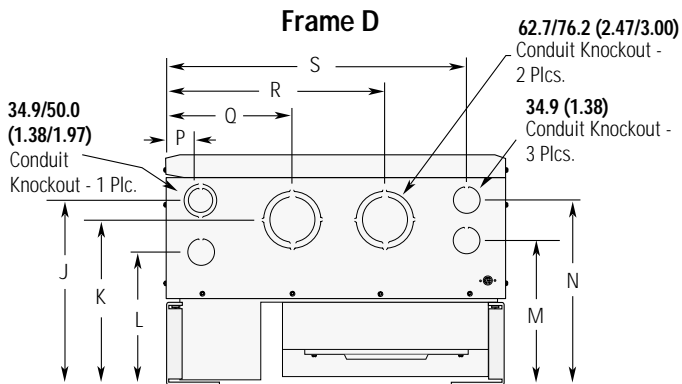

| Frame Reference | J               | K               | L               | M               | N               | P              | Q               | R                | S                |
|-----------------|-----------------|-----------------|-----------------|-----------------|-----------------|----------------|-----------------|------------------|------------------|
| D               | 198.1<br>(7.80) | 169.4<br>(6.67) | 131.6<br>(5.18) | 153.7<br>(6.05) | 204.5<br>(8.05) | 52.1<br>(2.05) | 144.0<br>(5.67) | 261.4<br>(10.29) | 343.9<br>(13.54) |

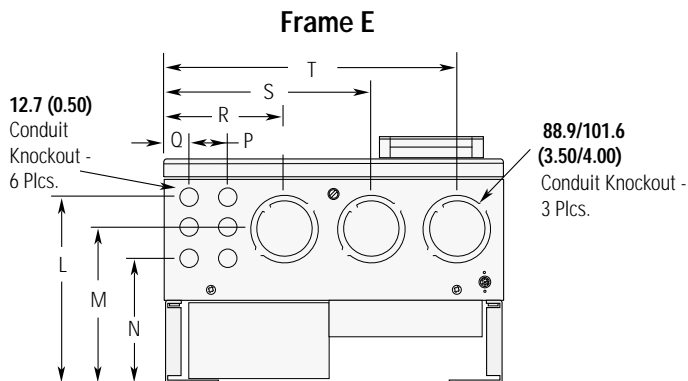

| Frame Reference | L                | M                | N               | P             | Q              | R               | S                | T                |
|-----------------|------------------|------------------|-----------------|---------------|----------------|-----------------|------------------|------------------|
| E               | 311.2<br>(12.25) | 260.4<br>(10.25) | 209.6<br>(8.25) | 50.8<br>(2.0) | 38.6<br>(1.52) | 178.3<br>(7.02) | 305.3<br>(12.02) | 432.3<br>(17.02) |

For Frame Reference refer to the Derating Guidelines on **Pages 43 to 51** for derating information.

## Mounting and Spacing Requirements

### Approved Mounting Methods for Wall Mounting Enclosures

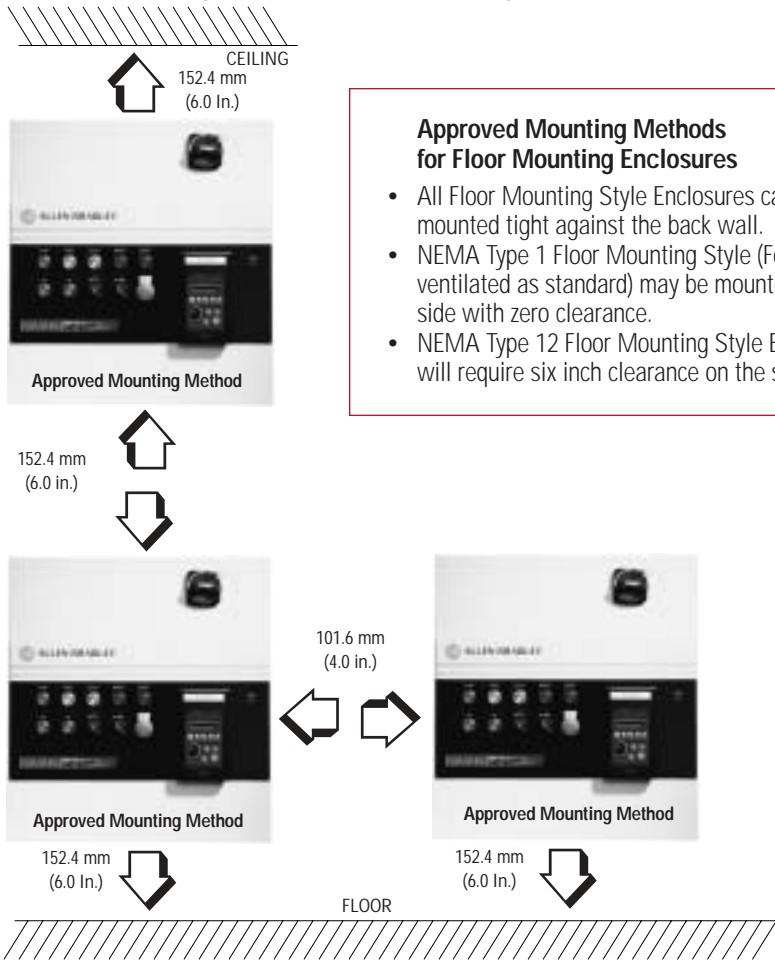

### Approved Mounting Methods for Floor Mounting Enclosures

- All Floor Mounting Style Enclosures can be mounted tight against the back wall.
- NEMA Type 1 Floor Mounting Style (Force ventilated as standard) may be mounted side by side with zero clearance.
- NEMA Type 12 Floor Mounting Style Enclosures will require six inch clearance on the sides.

### Not Acceptable

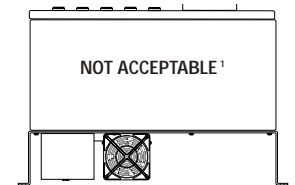

<sup>1</sup> Some horizontal mounting conventions are acceptable provided the application and packaging is reviewed with Allen-Bradley.

## Input Conditioning

In general, the 1336 IMPACT drive is suitable for direct connection to a correct voltage AC line that has a minimum impedance of 1% (3% for 0.37-22 kW/0.5-30 HP drives) relative to the rated drive input kVA. If the line has a lower impedance, a line reactor or isolation transformer must be added before the drive to increase line impedance. If the line impedance is too low, transient voltage spikes or interruptions can create excessive current spikes that will cause nuisance input fuse blowing and may cause damage to the drive power structure.

The basic rules for determining if a line reactor or isolation type transformer is required are as follows:

1. If the AC input power system does not have a neutral or one phase referenced to ground (Refer to **Ungrounded Distribution Systems**), an isolation transformer with the neutral of the secondary grounded is highly recommended. If the line-to-ground voltages on any phase can exceed 125% of the nominal line-to-line voltage, an isolation transformer with the neutral of the secondary grounded, is always required.
2. If the AC line supplying the drive has power factor correction capacitors that are switched in and out, an isolation transformer or 5% reactors are recommended between the capacitors and drive. If the capacitors are permanently connected and not switched, the general rules for impedance mismatch above apply.
3. If the AC line frequently experiences transient power interruptions or significant voltage spikes, an isolation transformer or 5% reactors are recommended.

Line reactors and isolation transformers can be ordered as loose items or installed in the drive enclosure.

## AC Supply Source

1336 IMPACT drives are suitable for use on a circuit capable of delivering up to a maximum of 200,000 rms symmetrical amperes, 600 volts maximum when used with the AC input line fuses specified on **Page 32**.

# 1336 IMPACT AC Drive Pre-Installation

## Typical Component and Terminal Block Locations



**ATTENTION:** The national codes and standards (NEC, VDE, BSA, etc.) and local codes outline provisions for safely installing electrical equipment. Installation must comply with specifications regarding wire type, conductor sizes, branch circuit protection, and disconnect devices. Failure to do so may result in personal injury and/or equipment damage.

TB1 Power Terminal Block  
TB4, 7, 10 Control & Signal Wiring  
TB3 Control Interface Option

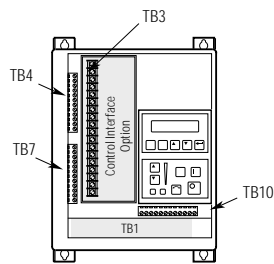

Frame Reference A1-A4

TB1 Power Terminal Block  
TB10, 11 Control & Signal Wiring  
TB3 Control Interface Option  
TB4 24V DC Auxiliary Input  
TB6 High Voltage DC Auxiliary Input  
TB9 480V Output (F Frame Only)  
TE Shield Terminals

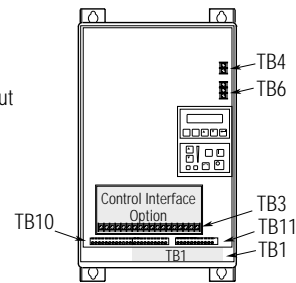

Frames B, C

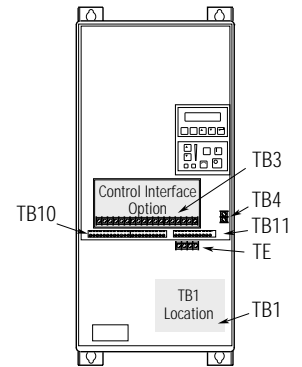

Frames D, E

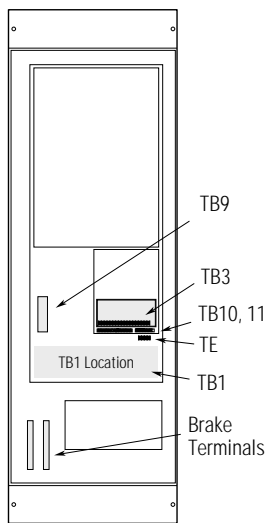

Frame F

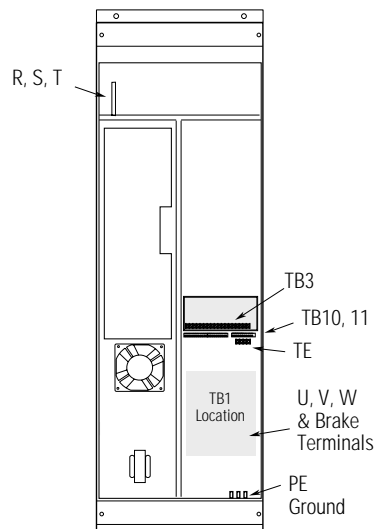

Frame G

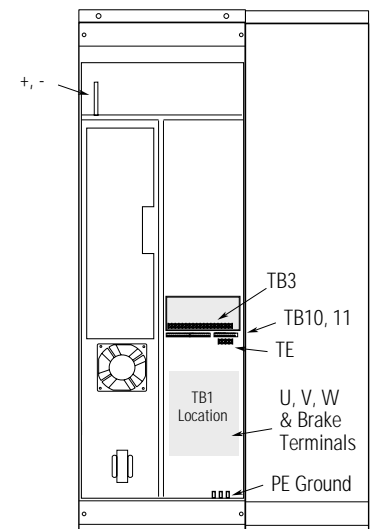

Frame H  
(Preliminary)

## Power Wiring

Input and output power connections are performed through terminal block, TB1. For maintenance and setup procedures, the drive may be operated without a motor connected.



**ATTENTION:** If you install control and signal wiring with an insulation rating of less than 600V, you must route this wiring inside the drive enclosure so that it is separated from any other wiring and uninsulated live parts. If you do not separate these wires, you may damage your equipment or have unsatisfactory drive performance.



**ATTENTION:** The hazard for injury or death from electric shock may exist if a disconnecting means is wired to drive output terminals and is opened during drive operation. Any disconnecting means wired to drive output terminals U, V, and W must be capable of disabling the drive if opened during drive operation. An auxiliary contact must be used to simultaneously disable the drive.

## Input Fuses and Circuit Breakers

1336 IMPACT drive can be installed with either input fuses or an input circuit breaker. Local/national electrical codes may determine additional requirements for these installations.

## Installations Per U.S. NEC/UL/CSA

### Fuses

In general, the specified fuses are suitable for branch short circuit protection and provide excellent short circuit protection for the drive. The fuses offer a high interrupting capacity and are fast acting. Refer to the North American selections in the table on **Page 32**.

### Circuit Breakers

The Westinghouse HMCP breakers specified in the table on **Page 26-27** also provide branch short circuit protection. Because circuit breakers are typically slower than fuses and those listed are magnetic trip only, they may not be as effective in offering short circuit protection to the drive in the event of an internal drive short circuit. They may not be as effective in limiting damage to the drive.

## IEC Installations

### Fuses

For those installations that are not required to meet the U.S. NEC/UL/CSA, the specified fuses are suitable for branch short circuit protection and provide excellent short circuit protection for the drive. The fuses offer a high interrupting capacity and are fast acting. Refer to the European selections in the table on **Page 32**.

### Circuit Breakers

For those installations that are not required to meet the U.S. NEC/UL/CSA requirements, additional devices are available as input circuit breakers. The Bulletin 140 and KTA3 devices meet the circuit breaker requirements of IEC947-2, but do not meet UL/CSA circuit breaker requirements. They can be used in "non-U.S." installations where local/national codes allow, if they are installed per their installation instructions.



**ATTENTION:** The 1336 IMPACT drive does not provide input power short circuit protection. Specifications for the recommended fuse or circuit breaker to provide drive input power protection against short circuits are provided.

# 1336 IMPACT AC Drive Pre-Installation

## Recommended AC Line Circuit Breakers (user supplied)

| Drive<br>Catalog Number | Maximum<br>Rated VT<br>kW (HP) | IEC Installations per IEC947-2            |                                           | UL/CSA Installations              |                     |                                         |
|-------------------------|--------------------------------|-------------------------------------------|-------------------------------------------|-----------------------------------|---------------------|-----------------------------------------|
|                         |                                | Bulletin 140 Circuit Breaker <sup>1</sup> |                                           | HMCP Circuit Breaker <sup>2</sup> |                     |                                         |
|                         |                                | Catalog Number                            | Rated Service Short<br>Circuit Capability | Catalog Number                    | MCP Trip<br>Setting | Max. Short<br>Circuit Amps <sup>3</sup> |
|                         |                                |                                           | <b>400/415V</b>                           |                                   |                     | <b>480V</b>                             |
| 1336E-AQF05             | 0.37 (0.5)                     | 140-MN-0400                               | 100,000                                   | HMCP5007C0                        | H                   | 65,000                                  |
| 1336E-AQF07             | 0.56 (0.75)                    | 140-MN-0400                               | 100,000                                   | HMCP5015E0C                       | E                   | 65,000                                  |
| 1336E-AQF10             | 0.75 (1)                       | 140-MN-0630                               | 100,000                                   | HMCP5015E0C                       | E                   | 65,000                                  |
| 1336E-AQF15             | 1.2 (1.5)                      | 140-MN-1000                               | 16,000                                    | HMCP5015E0C                       | F                   | 65,000                                  |
| 1336E-AQF20             | 1.5 (2)                        | 140-MN-1000                               | 16,000                                    | HMCP5030H1C                       | E                   | 65,000                                  |
| 1336E-AQF30             | 2.2 (3)                        | 140-MN-1600                               | 6,000                                     | HMCP5030H1C                       | F                   | 65,000                                  |
| 1336E-AQF50             | 3.7 (5)                        | 140-MN-2500                               | 6,000                                     | HMCP5030H1C                       | H                   | 65,000                                  |
| 1336E-A007              | 5.5 (7.5)                      | 140-CMN-4000                              | 65,000                                    | HMCP5030H1C                       | H                   | 65,000                                  |
| 1336E-A010              | 7.5 (10)                       | 140-CMN-4000                              | 65,000                                    | HMCP5050K2C                       | F                   | 65,000                                  |
| 1336E-A015              | 11 (15)                        | 140-CMN-6300                              | 50,000                                    | HMCP5050K2C                       | H                   | 65,000                                  |
| 1336E-A020              | 15 (20)                        | 140-CMN-6300                              | 50,000                                    | HMCP5100R3C                       | G                   | 65,000                                  |
| 1336E-A025              | 18.5 (25)                      | 140-CMN-9000                              | 25,000                                    | HMCP5100R3C                       | H                   | 65,000                                  |
| 1336E-A030              | 22 (30)                        | 140-CMN-9000                              | 25,000                                    | HMCP5100R3C                       | H                   | 65,000                                  |
| 1336E-A040              | 30 (40)                        | KTA3-160S-125                             | 65,000                                    | HMCP150T4C                        | F                   | 65,000                                  |
| 1336E-A050              | 37 (50)                        | KTA3-160S-160                             | 65,000                                    | HMCP150T4C                        | G                   | 65,000                                  |
| 1336E-A060              | 45 (60)                        | KTA3-250S-200                             | 65,000                                    | HMCP250A5                         | E                   | 65,000                                  |
| 1336E-A075              | 56 (75)                        | KTA3-250S-250                             | 65,000                                    | HMCP250A5                         | E                   | 65,000                                  |
| 1336E-A100              | 75 (100)                       | KTA3-400S-320                             | 65,000                                    | HMCP400J5                         | I                   | 65,000                                  |
| 1336E-A125              | 93 (125)                       | KTA3-400S-320                             | 65,000                                    | HMCP400J5                         | I                   | 65,000                                  |
| 1336E-BRF05             | 0.37 (0.5)                     | 140-MN-0250                               | 100,000                                   | HMCP5003A0                        | E                   | 65,000                                  |
| 1336E-BRF07             | 0.56 (0.75)                    | 140-MN-0250                               | 100,000                                   | HMCP5003A0                        | G                   | 65,000                                  |
| 1336E-BRF10             | 0.75 (1)                       | 140-MN-0400                               | 100,000                                   | HMCP5003A0                        | G                   | 65,000                                  |
| 1336E-BRF15             | 1.2 (1.5)                      | 140-MN-0400                               | 100,000                                   | HMCP5007C0                        | B                   | 65,000                                  |
| 1336E-BRF20             | 1.5 (2)                        | 140-MN-0630                               | 100,000                                   | HMCP5007C0                        | C                   | 65,000                                  |
| 1336E-BRF30             | 2.2 (3)                        | 140-MN-1000                               | 16,000                                    | HMCP5015E0C                       | B                   | 65,000                                  |
| 1336E-BRF50             | 3.7 (5)                        | 140-MN-1000                               | 16,000                                    | HMCP5015E0C                       | D                   | 65,000                                  |
| 1336E-BRF75             | 5.5 (7.5)                      | 140-MN-1600                               | 6,000                                     | HMCP5015E0C                       | H                   | 65,000                                  |
| 1336E-BRF100            | 7.5 (10)                       | 140-MN-2000                               | 6,000                                     | HMCP5030H1C                       | H                   | 65,000                                  |
| 1336E-B010              | 11 (15)                        | 140-MN-2000                               | 6,000                                     | HMCP5030H1C                       | E                   | 65,000                                  |
| 1336E-B015              | 15 (20)                        | 140-MN-2500                               | 6,000                                     | HMCP5030H1C                       | H                   | 65,000                                  |
| 1336E-B020              | 18.5 (25)                      | 140-CMN-4000                              | 65,000                                    | HMCP5050K2C                       | H                   | 65,000                                  |
| 1336E-B025              | 22 (30)                        | 140-CMN-4000                              | 65,000                                    | HMCP5050K2C                       | H                   | 65,000                                  |
| 1336E-B030              | 22 (30)                        | 140-CMN-6300                              | 50,000                                    | HMCP5050K2C                       | H                   | 65,000                                  |
| 1336E-BX040             | 30 (40)                        | 140-CMN-6300                              | 50,000                                    | HMCP5050K2C                       | H                   | 65,000                                  |
| 1336E-B040              | 37 (50)                        | 140-CMN-6300                              | 50,000                                    | HMCP5100R3C                       | G                   | 65,000                                  |
| 1336E-B050              | 45 (60)                        | 140-CMN-9000                              | 25,000                                    | HMCP5100R3C                       | G                   | 65,000                                  |
| 1336E-BX060             | 45 (60)                        | 140-CMN-9000                              | 25,000                                    | HMCP5100R3C                       | G                   | 65,000                                  |
| 1336E-B060              | 56 (75)                        | KTA3-160S-125                             | 65,000                                    | HMCP510T4C                        | F                   | 65,000                                  |
| 1336E-B075              | 75 (100)                       | KTA3-160S-125                             | 65,000                                    | HMCP510T4C                        | H                   | 65,000                                  |
| 1336E-B100              | 93 (125)                       | KTA3-160S-160                             | 65,000                                    | HMCP510U4C                        | E                   | 65,000                                  |
| 1336E-B125              | 112 (150)                      | KTA3-250S-200                             | 65,000                                    | HMCP250K5                         | H                   | 65,000                                  |
| 1336E-BX150             | 112 (150)                      | KTA3-250S-200                             | 65,000                                    | HMCP250K5                         | H                   | 65,000                                  |
| 1336E-B150              | 149 (200)                      | KTA3-400S-320                             | 65,000                                    | HMCP250L5                         | I                   | 65,000                                  |
| 1336E-B200              | 187 (250)                      | KTA3-400S-320                             | 65,000                                    | HMCP400N5                         | H                   | 65,000                                  |
| 1336E-B250              | 224 (300)                      | KTA3-400S-400                             | 65,000                                    | HMCP400N5                         | I                   | 65,000                                  |
| 1336E-BP250             | 224 (300)                      | KTA3-400S-400                             | 65,000                                    | HMCP400R5                         | I                   | 65,000                                  |
| 1336E-B300              | 261 (350)                      | NA                                        | —                                         | NA                                | —                   | —                                       |
| 1336E-BP300             | 261 (350)                      | KTA3-400S-400                             | 65,000                                    | HMCP400R5                         | I                   | 65,000                                  |
| 1336E-B350              | 298 (400)                      |                                           |                                           | NA                                | —                   | —                                       |
| 1336E-BP350             | 261 (350)                      |                                           |                                           | HMCP600L6W                        | E                   | 65,000                                  |
| 1336E-B400              | 336 (450)                      |                                           |                                           | NA                                | —                   | —                                       |
| 1336E-BP400             | 298 (400)                      |                                           |                                           | HMCP600L6W                        | E                   | 65,000                                  |
| 1336E-B450              | 373 (500)                      |                                           |                                           | NA                                | —                   | —                                       |
| 1336E-BP450             | 336 (450)                      |                                           |                                           | HMCP600L6W                        | E                   | 65,000                                  |
| 1336E-B500              | 448 (600)                      |                                           |                                           | NA                                | —                   | —                                       |
| 1336E-B600              | 448 (600)                      |                                           |                                           | NA                                | —                   | —                                       |

# 1336 IMPACT AC Drive Pre-Installation

## Recommended AC Line Circuit Breakers (user supplied) (continued)

| Drive<br>Catalog Number | Maximum<br>Rated VT<br>kW (HP) | IEC Installations per IEC947-2            |                                           | UL/CSA Installations              |                     |                                         |
|-------------------------|--------------------------------|-------------------------------------------|-------------------------------------------|-----------------------------------|---------------------|-----------------------------------------|
|                         |                                | Bulletin 140 Circuit Breaker <sup>1</sup> |                                           | HMCP Circuit Breaker <sup>2</sup> |                     |                                         |
|                         |                                | Catalog Number                            | Rated Service Short<br>Circuit Capability | Catalog Number                    | MCP Trip<br>Setting | Max. Short<br>Circuit Amps <sup>3</sup> |
|                         |                                |                                           | <b>400/415V</b>                           |                                   |                     | <b>480V</b>                             |
| 1336E-C001              | 0.75 (1)                       | 140-MN-0400                               | 100,000                                   | HMCP5003A0                        | E                   | 65,000                                  |
| 1336E-C003              | 2.2 (3)                        | 140-MN-0630                               | 100,000                                   | HMCP5007C0                        | E                   | 65,000                                  |
| 1336E-C007              | 5.5 (7.5)                      | 140-MN-1000                               | 16,000                                    | HMCP5015E0C                       | E                   | 65,000                                  |
| 1336E-C010              | 7.5 (10)                       | 140-MN-1600                               | 6,000                                     | HMCP5015E0C                       | E                   | 65,000                                  |
| 1336E-C015              | 11 (15)                        | 140-MN-2000                               | 6,000                                     | HMCP5030H1C                       | F                   | 65,000                                  |
| 1336E-C020              | 15 (20)                        | 140-MN-2500                               | 6,000                                     | HMCP5030H1C                       | H                   | 65,000                                  |
| 1336E-C025              | 18.5 (25)                      | 140-CMN-4000                              | 65,000                                    | HMCP5050K2C                       | E                   | 65,000                                  |
| 1336E-C030              | 22 (30)                        | 140-CMN-4000                              | 65,000                                    | HMCP5050K2C                       | G                   | 65,000                                  |
| 1336E-C040              | 30 (40)                        | 140-CMN-6300                              | 50,000                                    | HMCP5050K2C                       | G                   | 65,000                                  |
| 1336E-C050              | 37 (50)                        | 140-CMN-6300                              | 50,000                                    | HMCP100R3C                        | E                   | 65,000                                  |
| 1336E-C060              | 45 (60)                        | 140-CMN-6300                              | 50,000                                    | HMCP100R3C                        | E                   | 65,000                                  |
| 1336E-C075              | 56 (75)                        | 140-CMN-9000                              | 25,000                                    | HMCP100R3C                        | G                   | 65,000                                  |
| 1336E-C100              | 75 (100)                       | KTA3-160S-125                             | 65,000                                    | HMCP150T4C                        | E                   | 65,000                                  |
| 1336E-C125              | 93 (125)                       | KTA3-160S-160                             | 65,000                                    | HMCP150T4C                        | E                   | 65,000                                  |
| 1336E-C150              | 112 (150)                      | KTA3-400S-160                             | 65,000                                    | HMCP250J5                         | G                   | 65,000                                  |
| 1336E-C200              | 149 (200)                      | KTA3-400S-320                             | 65,000                                    | HMCP250K5                         | I                   | 65,000                                  |
| 1336E-C250              | 187 (250)                      | KTA3-400S-320                             | 65,000                                    | HMCP400W5                         | G                   | 65,000                                  |
| 1336E-CX300             | 224 (300)                      | KTA3-400S-320                             | 65,000                                    | HMCP400W5                         | H                   | 65,000                                  |
| 1336E-C300              | 224 (300)                      | KTA3-400S-320                             | 65,000                                    |                                   |                     |                                         |
| 1336E-C350              | 261 (350)                      | KTA3-400S-400                             | 65,000                                    |                                   |                     |                                         |
| 1336E-C400              | 298 (400)                      | KTA3-400S-400                             | 65,000                                    |                                   |                     |                                         |
| 1336E-C450              | 336 (450)                      |                                           |                                           |                                   |                     |                                         |
| 1336E-C500              | 373 (500)                      |                                           |                                           |                                   |                     |                                         |
| 1336E-C600              | 448 (600)                      |                                           |                                           |                                   |                     |                                         |
|                         |                                | NA                                        |                                           |                                   | NA                  |                                         |

NA = Not Available – No device exists, uses fuses shown on **Page 32**.

<sup>1</sup> Bulletin 140 – At 480 volts, circuit breaker must have a fuse backup. Refer to the AB Industrial Control Catalog. At 600 volts, additional restrictions apply. Not limitations in source short circuit ratings.

<sup>2</sup> HMCP Circuit Breaker – HMCP Breaker is a magnetic trip device only. Always set the trip setting as low as possible in a particular application. Note information in HMCP application handbook.

<sup>3</sup> Current limiting option can extend this value to 200,000A RMS.

# 1336 IMPACT AC Drive Pre-Installation

## Power Wiring — TB1

### A1-A3 Frame

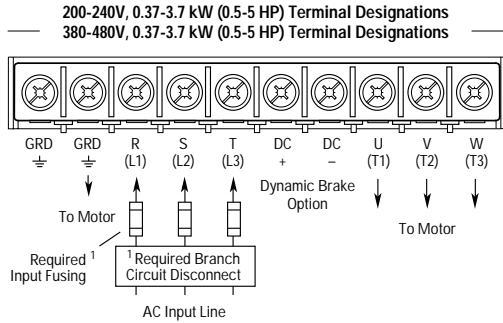

### A4 Frame

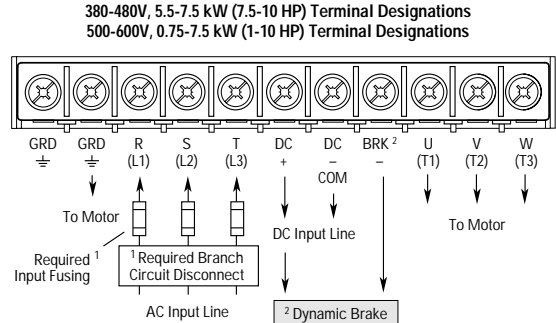

### B1 Frame

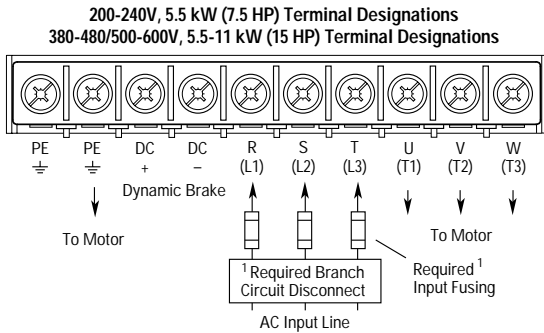

### B2 Frame

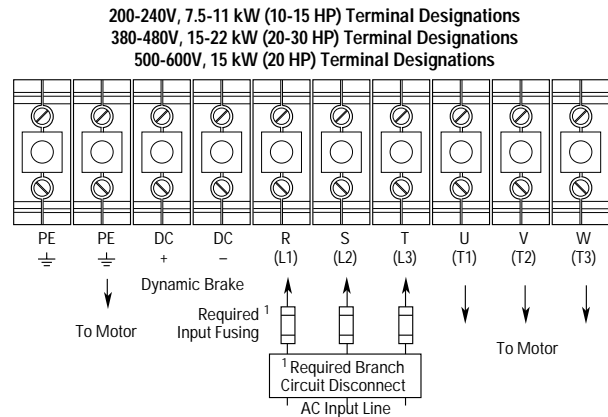

### C Frame

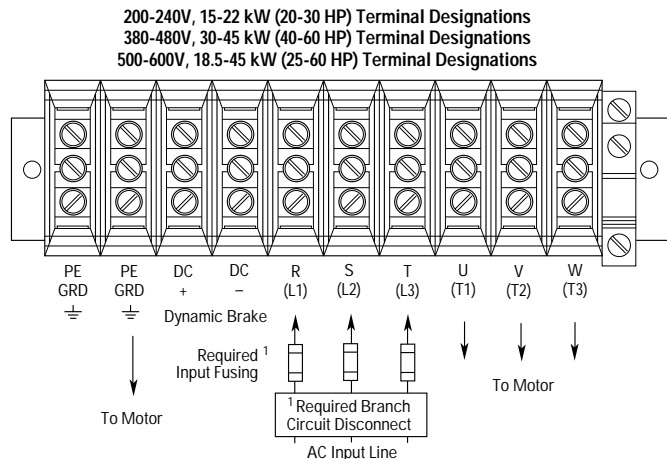

<sup>1</sup> User supplied.

<sup>2</sup> Before wiring your dynamic brake for the A4 frame, double check the terminals. You should attach the + terminal on the brake to the DC+ terminal on your drive and the - terminal on the brake to the BRK - terminal on your drive. If your BRK - terminal is labeled VBUS -, connect the - terminal on the brake to the VBUS - terminal on your drive.

## Power Wiring — TB1

200-240V, 30-45 kW (40-60 HP) Terminal Designations  
 380-480V, 45-112 kW (60-150 HP) Terminal Designations  
 500-600V, 56-112 kW (75-150 HP) Terminal Designations

### D Frame

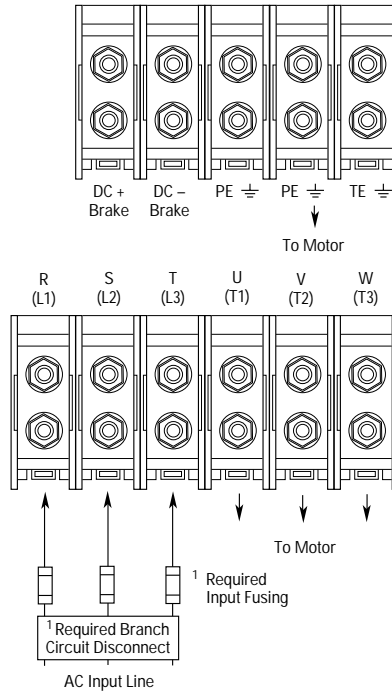

200-240V, 56-75 kW (75-100 HP) Terminal Designations  
 380-480V, 112-187 kW (150-250 HP) Terminal Designations  
 500-600V, 112-149 kW (150-200 HP) Terminal Designations

### E Frame

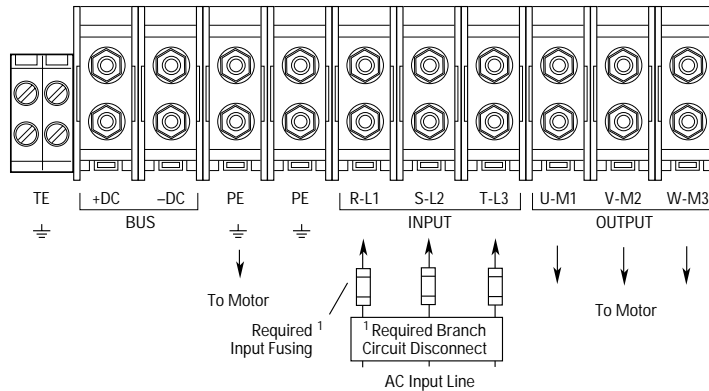

<sup>1</sup> User supplied.

# 1336 IMPACT AC Drive Pre-Installation

## Power Wiring — TB1

380-480V, 187-336 kW (250-450 HP) Terminal Designations

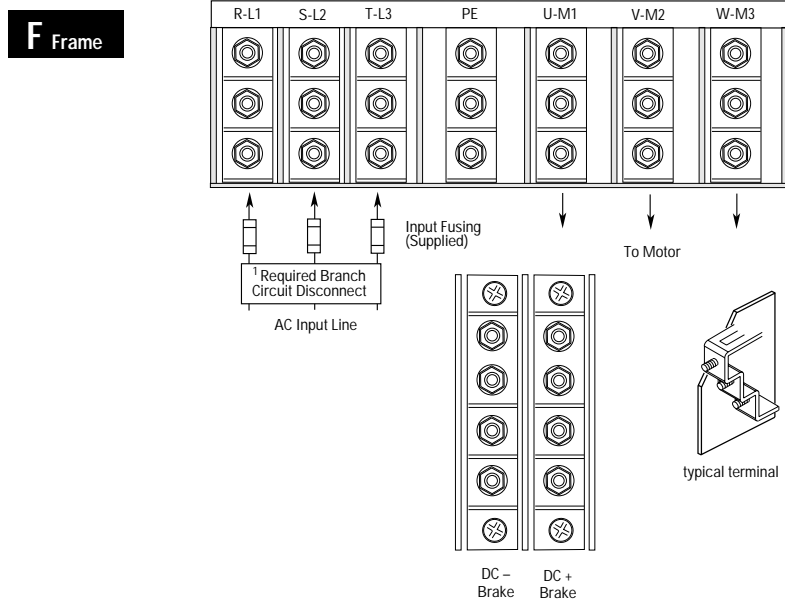

380-480V, 224-448 kW (300-600 HP) Terminal Designations  
500-600V, 187-448 kW (250-600 HP) Terminal Designations

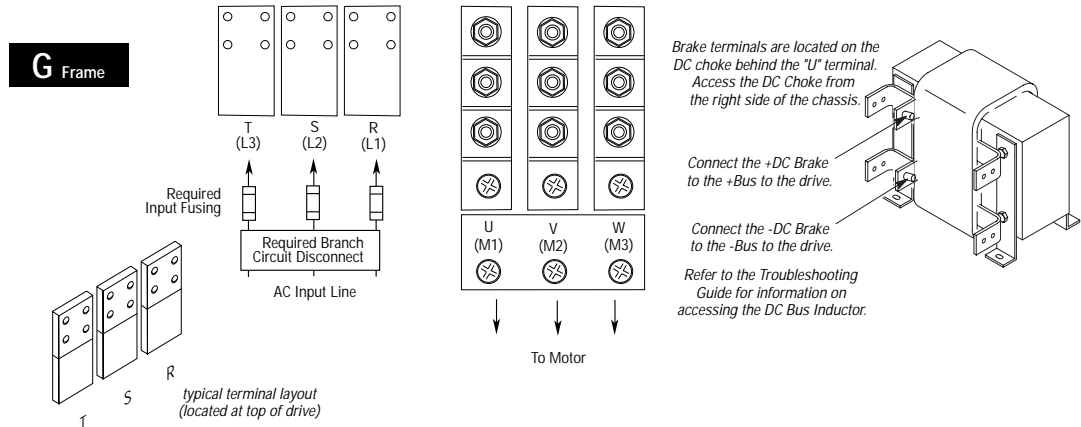

380-480V, 522-597 kW (700-800 HP) Terminal Designations  
500-600V, 522-597 kW (700-800 HP) Terminal Designations

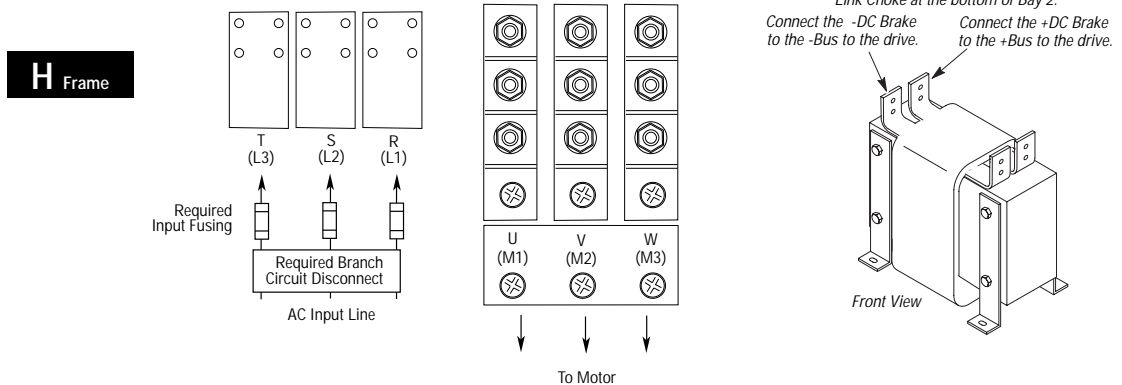

<sup>1</sup> User supplied.

## Power Wiring — TB1





**ATTENTION:** An incorrectly applied or installed system can result in component damage or reduction in product life. The most common causes are:

- Wiring AC line to drive output or control terminals.
- Output circuits which do not connect directly to the motor.
- Incorrect or inadequate AC supply.
- Excessive ambient temperature.

Contact Allen-Bradley for assistance with application or wiring.

## Power Wiring — TB1

| Terminal                                                                             | Description             |
|--------------------------------------------------------------------------------------|-------------------------|
| PE  | Power earth ground      |
| TE  | True earth ground       |
| R (L1), S (L2), T (L3)                                                               | AC Line Input Terminals |
| +DC, -DC                                                                             | DC Bus Terminals        |
| U (T1), V (T2), W (T3)                                                               | Motor Connection        |

## TB1 Specifications — Use 75° C Rated Copper Wire Only

| Terminal Block Type      | Max./Min. Wire Size <sup>1</sup><br>mm <sup>2</sup> (AWG) | Maximum Torque<br>N-m (lb.-in.) <sup>1</sup> |
|--------------------------|-----------------------------------------------------------|----------------------------------------------|
| A1 -A4 (Page 28)         | 5.3/0.8 (10/18)                                           | 1.81 (16)                                    |
| B1 (Page 28)             | 8.4/0.8 (8/18)                                            | 1.81 (16)                                    |
| B2 (Page 28)             | 13.3/0.5 (6/20)                                           | 1.70 (15)                                    |
| C (Page 28)              | 26.7/0.8 (3/18)                                           | 5.65 (50)                                    |
| D (Page 29) <sup>3</sup> | 127.0/2.1 (250 MCM/14)<br>67.4/2.1 (00/14) <sup>2</sup>   | 6.00 (52)<br>6.00 (52)                       |
| E (Page 29) <sup>3</sup> | 253.0/2.1 (500 MCM/14)                                    | 10.00 (87)                                   |
| F (Page 30) <sup>3</sup> | 303.6/2.1 (600 MCM/14)                                    | 23.00 (200)                                  |
| G (Page 30) <sup>3</sup> | 303.6/2.1 (600 MCM/14)                                    | 23.00 (200)                                  |
| H (Page 30) <sup>3</sup> | 303.6/2.1 (600 MCM/14)                                    | 23.00 (200)                                  |

<sup>1</sup> Wire sizes given are maximum/minimum sizes that TB1 will accept – these are not recommendations.

<sup>2</sup> Applies to 30 kW (40 HP) 200-240V, 45 & 56 kW (60 & 75 HP) 380-480V, 56 kW (75 HP) 500-600V drives only.

<sup>3</sup> These configurations of TB1 are stud type terminations and require the use of lug type connectors to terminate the field installed conductors. Lug kits (1336-LUG-xxxx) are available for use with these configurations. Wire size used is determined by selecting the proper lug kit based on the drive catalog number.

# 1336 IMPACT AC Drive Pre-Installation

## Power Wiring — TB1



**ATTENTION:** The 1336 IMPACT does not provide input power short circuit fusing. Specifications for the recommended fuse size and type to provide drive input power protection against short circuits are provided below. Branch circuit breakers or disconnect switches cannot provide this level of protection for drive components.

### Maximum Recommended AC Input Line Fuse Ratings – fuses are user supplied

| European Installations                                                                                                                                                                                                                                                                                                                                                                                                                                                          | North American Installations                                                                                                                                                                                                     | Drive Catalog Number       | kW (HP) Rating       | 200-240V Rating  | 380-480V Rating   | 500-600V Rating   |
|---------------------------------------------------------------------------------------------------------------------------------------------------------------------------------------------------------------------------------------------------------------------------------------------------------------------------------------------------------------------------------------------------------------------------------------------------------------------------------|----------------------------------------------------------------------------------------------------------------------------------------------------------------------------------------------------------------------------------|----------------------------|----------------------|------------------|-------------------|-------------------|
| <p>The recommended fuse is Class gG, general industrial applications and motor circuit protection.</p> <p>BS88 (British Standard) Parts 1 &amp; 2 *, EN60269-1, Parts 1 &amp; 2, type gG or equivalent should be used for these drives. Fuses that meet BS88 Parts 1 &amp; 2 are acceptable for Frames A - F.</p> <p>* Typical designations include, but may not be limited to the following:<br/>Parts 1 &amp; 2: AC, AD, BC, BD, CD, DD, ED, EFS, EF, FF, FG, GF, GG, GH.</p> | <p>UL requirements specify that UL Class CC, T or J<sup>1</sup> fuses must be used for all drives in this section*.</p> <p>* Typical designations include:<br/>Type CC: KTK, FNQ-R<br/>Type J: JKS, LPJ<br/>Type T: JJS, JJN</p> | 1336E-__ F05, 7            | 0.37-0.56 (0.5-0.75) | 6A <sup>4</sup>  | 3A <sup>4</sup>   | —                 |
|                                                                                                                                                                                                                                                                                                                                                                                                                                                                                 |                                                                                                                                                                                                                                  | 1336E-__ F10               | 0.75 (1)             | 10A <sup>4</sup> | 6A <sup>4</sup>   | 3A                |
|                                                                                                                                                                                                                                                                                                                                                                                                                                                                                 |                                                                                                                                                                                                                                  | 1336E-__ F15               | 1.2 (1.5)            | 15A <sup>4</sup> | 6A <sup>4</sup>   | —                 |
|                                                                                                                                                                                                                                                                                                                                                                                                                                                                                 |                                                                                                                                                                                                                                  | 1336E-__ F20               | 1.5 (2)              | 15A <sup>4</sup> | 10A <sup>4</sup>  | 6A                |
|                                                                                                                                                                                                                                                                                                                                                                                                                                                                                 |                                                                                                                                                                                                                                  | 1336E-__ F30               | 2.2 (3)              | 25A <sup>4</sup> | 15A <sup>4</sup>  | 10A               |
|                                                                                                                                                                                                                                                                                                                                                                                                                                                                                 |                                                                                                                                                                                                                                  | 1336E-__ F50               | 3.7 (5)              | 40A <sup>4</sup> | 20A <sup>4</sup>  | 10A               |
|                                                                                                                                                                                                                                                                                                                                                                                                                                                                                 |                                                                                                                                                                                                                                  | 1336E-__ F75               | 5.5 (7.5)            | 40A              | 20A               | 15A               |
|                                                                                                                                                                                                                                                                                                                                                                                                                                                                                 |                                                                                                                                                                                                                                  | 1336E-__ F100              | 7.5 (10)             | 50A              | 30A               | 20A               |
|                                                                                                                                                                                                                                                                                                                                                                                                                                                                                 |                                                                                                                                                                                                                                  | 1336E-__ 001               | 0.75 (1)             | 10A              | 6A                | 6A                |
|                                                                                                                                                                                                                                                                                                                                                                                                                                                                                 |                                                                                                                                                                                                                                  | 1336E-__ 003               | 2.2 (3)              | 15A              | 10A               | 10A               |
|                                                                                                                                                                                                                                                                                                                                                                                                                                                                                 |                                                                                                                                                                                                                                  | 1336E-__ 007               | 5.5 (7.5)            | 40A              | 20A               | 15A               |
|                                                                                                                                                                                                                                                                                                                                                                                                                                                                                 |                                                                                                                                                                                                                                  | 1336E-__ 010               | 7.5 (10)             | 50A              | 30A               | 20A               |
|                                                                                                                                                                                                                                                                                                                                                                                                                                                                                 |                                                                                                                                                                                                                                  | 1336E-__ 015               | 11 (15)              | 70A              | 35A               | 25A               |
|                                                                                                                                                                                                                                                                                                                                                                                                                                                                                 |                                                                                                                                                                                                                                  | 1336E-__ 020               | 15 (20)              | 100A             | 45A               | 35A               |
|                                                                                                                                                                                                                                                                                                                                                                                                                                                                                 |                                                                                                                                                                                                                                  | 1336E-__ 025               | 18.5 (25)            | 100A             | 60A               | 40A               |
|                                                                                                                                                                                                                                                                                                                                                                                                                                                                                 |                                                                                                                                                                                                                                  | 1336E-__ 030               | 22 (30)              | 125A             | 70A               | 50A               |
|                                                                                                                                                                                                                                                                                                                                                                                                                                                                                 |                                                                                                                                                                                                                                  | 1336E-__ X040              | 30 (40)              | 150A             | 80A               | 60A               |
|                                                                                                                                                                                                                                                                                                                                                                                                                                                                                 |                                                                                                                                                                                                                                  | 1336E-__ 040               | 30 (40)              | 150A             | 80A               | 60A               |
|                                                                                                                                                                                                                                                                                                                                                                                                                                                                                 |                                                                                                                                                                                                                                  | 1336E-__ 050               | 37 (50)              | 200A             | 100A              | 80A               |
|                                                                                                                                                                                                                                                                                                                                                                                                                                                                                 |                                                                                                                                                                                                                                  | 1336E-__ X060              | 45 (60)              | —                | 100A              | —                 |
|                                                                                                                                                                                                                                                                                                                                                                                                                                                                                 |                                                                                                                                                                                                                                  | 1336E-__ 060               | 45 (60)              | 250A             | 125A              | 90A               |
|                                                                                                                                                                                                                                                                                                                                                                                                                                                                                 |                                                                                                                                                                                                                                  | 1336E-__ 075               | 56 (75)              | 300A             | 150A              | 110A              |
|                                                                                                                                                                                                                                                                                                                                                                                                                                                                                 |                                                                                                                                                                                                                                  | 1336E-__ 100               | 75 (100)             | 400A             | 200A              | 150A              |
|                                                                                                                                                                                                                                                                                                                                                                                                                                                                                 |                                                                                                                                                                                                                                  | 1336E-__ 125               | 93 (125)             | 450A             | 250A              | 175A              |
|                                                                                                                                                                                                                                                                                                                                                                                                                                                                                 |                                                                                                                                                                                                                                  | 1336E-__ X150              | 112 (150)            | —                | 250A              | —                 |
|                                                                                                                                                                                                                                                                                                                                                                                                                                                                                 |                                                                                                                                                                                                                                  | 1336E-__ 150               | 112 (150)            | —                | 300A              | 225A              |
| 1336E-__ 200                                                                                                                                                                                                                                                                                                                                                                                                                                                                    | 149 (200)                                                                                                                                                                                                                        | —                          | 400A                 | 350A             |                   |                   |
| 1336E-__ 250                                                                                                                                                                                                                                                                                                                                                                                                                                                                    | 187 (250)                                                                                                                                                                                                                        | —                          | 450A                 | 400A             |                   |                   |
| 1336E-__ X300                                                                                                                                                                                                                                                                                                                                                                                                                                                                   | 224 (300)                                                                                                                                                                                                                        | —                          | —                    | 400A             |                   |                   |
| <p>The recommended fuse is Class gG, general industrial applications and motor circuit protection.</p> <p>BS88 (British Standard) Part 4, EN60269-1, Part 4 *, type gG semiconductor fuses or equivalent should be used for these drives. G Frame drives require semiconductor fuses and should be fused with Part 4 fuses.</p> <p>* Typical designations include, but may not be limited to the following:<br/>Part 4: CT, ET, FE, EET, FEE, RFEE, FM, FMM.</p>                | <p>Bussmann FWP/Gould Shawmut A-70Q or QS semiconductor type fuses must be used for all drives in this section.</p>                                                                                                              | 1336E-__ 300               | 224 (300)            | —                | 500A              | 400A              |
|                                                                                                                                                                                                                                                                                                                                                                                                                                                                                 |                                                                                                                                                                                                                                  | 1336E-__ P300 <sup>2</sup> | 224 (300)            | —                | 500A <sup>2</sup> | —                 |
|                                                                                                                                                                                                                                                                                                                                                                                                                                                                                 |                                                                                                                                                                                                                                  | 1336E-__ 350               | 261 (350)            | —                | 600A              | 450A              |
|                                                                                                                                                                                                                                                                                                                                                                                                                                                                                 |                                                                                                                                                                                                                                  | 1336E-__ P350 <sup>2</sup> | 261 (350)            | —                | 600A <sup>2</sup> | —                 |
|                                                                                                                                                                                                                                                                                                                                                                                                                                                                                 |                                                                                                                                                                                                                                  | 1336E-__ 400               | 298 (400)            | —                | 600A              | 500A              |
|                                                                                                                                                                                                                                                                                                                                                                                                                                                                                 |                                                                                                                                                                                                                                  | 1336E-__ P400 <sup>2</sup> | 298 (400)            | —                | 600A <sup>2</sup> | —                 |
|                                                                                                                                                                                                                                                                                                                                                                                                                                                                                 |                                                                                                                                                                                                                                  | 1336E-__ 450               | 336 (450)            | —                | 800A              | 600A              |
|                                                                                                                                                                                                                                                                                                                                                                                                                                                                                 |                                                                                                                                                                                                                                  | 1336E-__ P450 <sup>2</sup> | 336 (450)            | —                | 700A <sup>2</sup> | —                 |
|                                                                                                                                                                                                                                                                                                                                                                                                                                                                                 |                                                                                                                                                                                                                                  | 1336E-__ 500               | 373 (500)            | —                | 800A              | 800A              |
|                                                                                                                                                                                                                                                                                                                                                                                                                                                                                 |                                                                                                                                                                                                                                  | 1336E-__ 600               | 448 (600)            | —                | 900A              | 800A              |
|                                                                                                                                                                                                                                                                                                                                                                                                                                                                                 |                                                                                                                                                                                                                                  | 1336E-__ 650               | 485 (650)            | —                | —                 | 800A              |
|                                                                                                                                                                                                                                                                                                                                                                                                                                                                                 |                                                                                                                                                                                                                                  | 1336E-__ 700C              | 522 (700)            | —                | 600A <sup>3</sup> | 700A <sup>3</sup> |
|                                                                                                                                                                                                                                                                                                                                                                                                                                                                                 |                                                                                                                                                                                                                                  | 1336E-__ 800C              | 597 (800)            | —                | 700A <sup>3</sup> | 700A <sup>3</sup> |

<sup>1</sup> For all types listed, both fast acting and slow blow are acceptable.

<sup>2</sup> Fuses are supplied with F frame drives.

<sup>3</sup> Two fuses in parallel are required.

<sup>4</sup> Dual element – time delay fuses are recommended.

## Motor Cables

A variety of cable types are acceptable for drive installations. For many installations, unshielded cable is adequate, provided it can be separated from sensitive circuits. As an approximate guide, allow a spacing of 0.3 meter (1 foot) for every 10 meters (32.8 feet) of length. In all cases, long parallel runs must be avoided. Do not use cable with an insulation thickness  $\leq$  15 mils.

The cable should be 4-conductor with the ground lead being connected directly to the drive ground terminal (PE) and the motor frame ground terminal.

### Shielded Cable

Shielded cable is recommended if sensitive circuits or devices are connected or mounted to the machinery driven by the motor. The shield must be connected to the drive ground and motor frame ground. It is important that the connection be made at both ends to minimize interference.

If cable trays or large conduits are to be used to distribute the motor leads for multiple drives, shielded cable is recommended to reduce or capture the noise from the motor leads and minimize "cross coupling" of noise between the leads of different drives. The shield should be connected to the ground connections at both the motor and drive ends.

Armored cable also provides effective shielding. Ideally it should be grounded only at the drive (PE) and motor frame. Some armored cable has a PVC coating over the armor to prevent incidental contact with grounded structure. If, due to the type of connector, the armor must be grounded at the cabinet entrance, shielded cable should be used within the cabinet if power leads will be run close to control signals.

### Conduit

If metal conduit is preferred for cable distribution, the following guidelines must be followed.

1. Drives are normally mounted in cabinets and ground connections are made at a common ground point in the cabinet. Normal installation of conduit provides grounded connections to both the motor frame (junction box) and drive cabinet ground. These ground connections help minimize interference. This is a noise reduction recommendation only and does not affect the requirements for safety grounding.
2. No more than three sets of motor leads can be routed through a single conduit. This will minimize "cross talk" that could reduce the effectiveness of the noise reduction methods described. If more than three drive/motor connections per conduit are required, shielded cable as described above must be used. If practical, each conduit should contain only one set of motor leads.



**ATTENTION:** To avoid a possible shock hazard caused by induced voltages, unused wires in the conduit must be grounded at both ends. For the same reason, if a drive sharing a conduit is being serviced or installed, all drives using this conduit should be disabled. This will eliminate the possible shock hazard from "cross coupled" drive motor leads.

### Motor Lead Lengths

Installations with long cables to the motor may require the addition of output reactors or cable terminators to limit voltage reflections at the motor. Refer to the table below for the maximum length cable allowed for various installation techniques. For installations that exceed the recommended maximum lengths listed, contact the factory.

### Cable Charging Current

While cable length limits for reflected wave protection should be followed, drives rated 0.37 to 1.2 kW (0.5 to 1.5 HP) may have additional cable length restrictions. Capacitive charging of long motor cables may divert current in excess of the rating of a smaller drive. To assure proper operation, limit smaller drives to the distances listed below, then take the appropriate protection for voltage reflection listed on **Pages 34 and 35**.

## Cable Derating for PWM Frequency – 0.37-1.2 KW (0.5-1.5 HP) Only

| Drive PWM Frequency | Shielded Cable | Unshielded Cable |
|---------------------|----------------|------------------|
| 2 kHz               | 91 m (300 ft.) | 91 m (300 ft.)   |
| 4 kHz               | 91 m (300 ft.) | 60 m (200 ft.)   |
| 8 kHz               | 30 m (100 ft.) | 30 m (100 ft.)   |
| 12 kHz              | 30 m (100 ft.) | 30 m (100 ft.)   |

# 1336 IMPACT AC Drive Pre-Installation

## Motor Cables

### Motor Lead Lengths

Installations with long cables to the motor may require the addition of output reactors or cable terminators to limit voltage reflections at the motor. Refer to the following tables for the maximum length cable allowed for various installation techniques. For installations that exceed the recommended maximum lengths listed, contact the factory.

### Maximum Motor Cable Length Restrictions — 380V-480V Drives<sup>1</sup>

|             |                   | No External Devices |           |            |             | w/1204-TFB2 Term.      |                               |             | w/1204-TFA1 Terminator        |             |            |             | Reactor at Drive <sup>2</sup> |             |             |             |             |
|-------------|-------------------|---------------------|-----------|------------|-------------|------------------------|-------------------------------|-------------|-------------------------------|-------------|------------|-------------|-------------------------------|-------------|-------------|-------------|-------------|
|             |                   | Motor               |           |            |             | Motor                  |                               |             | Motor                         |             |            |             | Motor                         |             |             |             |             |
| Drive Frame | Drive kW (HP)     | Motor kW (HP)       | A         | B          | 1329        | 1329R, HR & L          | A or B                        | 1329        | A                             | B           | 1329       | A           | B or 1329                     |             |             |             |             |
|             |                   |                     | Any Cable | Any Cable  | Any Cable   | Any Cable <sup>7</sup> | Cable Type Shld. <sup>3</sup> | Unshld.     | Cable Type Shld. <sup>3</sup> | Unshld.     | Any Cable  | Any Cable   | Any Cable                     |             |             |             |             |
| A1          | 0.37 (0.5)        | 0.37 (0.5)          | 12.2 (40) | 33.5 (110) | 114.3 (375) | 91.4 (300)             | Use 1204-TFA1 Terminator      |             | 30.5 (100)                    | 61.0 (200)  | 30.5 (100) | 61.0 (200)  | 182.9 (600)                   | 22.9 (75)   | 182.9 (600) |             |             |
|             | 0.75 (1)          | 0.75 (1)            | 12.2 (40) | 33.5 (110) | 114.3 (375) | 91.4 (300)             |                               | 30.5 (100)  | 30.5 (100)                    | 30.5 (100)  | 30.5 (100) | 182.9 (600) | 22.9 (75)                     | 182.9 (600) |             |             |             |
|             |                   | 0.37 (0.5)          | 12.2 (40) | 33.5 (110) | 114.3 (375) | 91.4 (300)             |                               | 30.5 (100)  | 61.0 (200)                    | 30.5 (100)  | 61.0 (200) | 182.9 (600) | 22.9 (75)                     | 182.9 (600) |             |             |             |
| A2          | 1.2 (1.5)         | 1.2 (1.5)           | 12.2 (40) | 33.5 (110) | 114.3 (375) | 91.4 (300)             |                               |             | 30.5 (100)                    | 30.5 (100)  | 61.0 (200) | 61.0 (200)  | 182.9 (600)                   | 22.9 (75)   | 182.9 (600) |             |             |
|             |                   | 0.75 (1)            | 12.2 (40) | 33.5 (110) | 114.3 (375) | 91.4 (300)             |                               | 30.5 (100)  | 30.5 (100)                    | 61.0 (200)  | 61.0 (200) | 182.9 (600) | 22.9 (75)                     | 182.9 (600) |             |             |             |
|             |                   | 0.37 (0.5)          | 12.2 (40) | 33.5 (110) | 114.3 (375) | 121.9 (400)            |                               | 30.5 (100)  | 30.5 (100)                    | 61.0 (200)  | 61.0 (200) | 182.9 (600) | 22.9 (75)                     | 182.9 (600) |             |             |             |
|             | 1.5 (2)           | 1.5 (2)             | 7.6 (25)  | 12.2 (40)  | 114.3 (375) | 91.4 (300)             |                               | 91.4 (300)  | 91.4 (300)                    | 91.4 (300)  | 30.5 (100) | 30.5 (100)  | 91.4 (300)                    | 61.0 (200)  | 182.9 (600) | 22.9 (75)   | 182.9 (600) |
|             |                   | 1.2 (1.5)           | 7.6 (25)  | 12.2 (40)  | 114.3 (375) | 182.9 (600)            |                               | 91.4 (300)  | 182.9 (600)                   | 182.9 (600) | 30.5 (100) | 30.5 (100)  | 91.4 (300)                    | 61.0 (200)  | 182.9 (600) | 22.9 (75)   | 182.9 (600) |
|             |                   | 0.75 (1)            | 7.6 (25)  | 12.2 (40)  | 114.3 (375) | 182.9 (600)            |                               | 182.9 (600) | 182.9 (600)                   | 182.9 (600) | 30.5 (100) | 30.5 (100)  | 91.4 (300)                    | 61.0 (200)  | 182.9 (600) | 22.9 (75)   | 182.9 (600) |
|             |                   | 0.37 (0.5)          | 7.6 (25)  | 12.2 (40)  | 114.3 (375) | 182.9 (600)            |                               | 182.9 (600) | 182.9 (600)                   | 182.9 (600) | 30.5 (100) | 30.5 (100)  | 91.4 (300)                    | 61.0 (200)  | 182.9 (600) | 22.9 (75)   | 182.9 (600) |
|             | 2.2 (3)           | 2.2 (3)             | 7.6 (25)  | 12.2 (40)  | 114.3 (375) | 91.4 (300)             |                               | 182.9 (600) | 182.9 (600)                   | 182.9 (600) |            |             |                               |             | 22.9 (75)   | 182.9 (600) |             |
|             |                   | 1.5 (2)             | 7.6 (25)  | 12.2 (40)  | 114.3 (375) | 182.9 (600)            |                               | 182.9 (600) | 182.9 (600)                   | 182.9 (600) | 30.5 (100) | 30.5 (100)  | 91.4 (300)                    | 61.0 (200)  | 182.9 (600) | 22.9 (75)   | 182.9 (600) |
|             |                   | 0.75 (1)            | 7.6 (25)  | 12.2 (40)  | 114.3 (375) | 182.9 (600)            | 182.9 (600)                   | 182.9 (600) | 182.9 (600)                   | 30.5 (100)  | 30.5 (100) | 91.4 (300)  | 61.0 (200)                    | 182.9 (600) | 22.9 (75)   | 182.9 (600) |             |
|             |                   | 0.37 (0.5)          | 7.6 (25)  | 12.2 (40)  | 114.3 (375) | 182.9 (600)            | 182.9 (600)                   | 182.9 (600) | 182.9 (600)                   | 30.5 (100)  | 30.5 (100) | 91.4 (300)  | 61.0 (200)                    | 182.9 (600) | 22.9 (75)   | 182.9 (600) |             |
|             | A3                | 3.7 (5)             | 3.7 (5)   | 7.6 (25)   | 12.2 (40)   | 114.3 (375)            |                               | 182.9 (600) | 182.9 (600)                   | 182.9 (600) |            |             |                               | 22.9 (75)   | 182.9 (600) |             |             |
|             |                   | 2.2 (3)             | 7.6 (25)  | 12.2 (40)  | 114.3 (375) |                        | 182.9 (600)                   | 182.9 (600) | 182.9 (600)                   |             |            |             | 22.9 (75)                     | 182.9 (600) |             |             |             |
|             |                   | 1.5 (2)             | 7.6 (25)  | 12.2 (40)  | 114.3 (375) |                        | 182.9 (600)                   | 182.9 (600) | 182.9 (600)                   |             |            |             | 22.9 (75)                     | 182.9 (600) |             |             |             |
|             |                   | 0.75 (1)            | 7.6 (25)  | 12.2 (40)  | 114.3 (375) |                        | 182.9 (600)                   | 182.9 (600) | 182.9 (600)                   |             |            |             | 22.9 (75)                     | 182.9 (600) |             |             |             |
|             |                   | 0.37 (0.5)          | 7.6 (25)  | 12.2 (40)  | 114.3 (375) |                        | 182.9 (600)                   | 182.9 (600) | 182.9 (600)                   |             |            |             | 22.9 (75)                     | 182.9 (600) |             |             |             |
| A4          | 5.5-7.5 (7.5-10)  | 5.5-7.5 (7.5-10)    | 7.6 (25)  | 12.2 (40)  | 114.3 (375) |                        | 182.9 (600)                   | 182.9 (600) | 182.9 (600)                   |             |            |             | 24.4 (80)                     | 182.9 (600) |             |             |             |
| B           | 5.5-22 (7.5-30)   | 5.5-22 (7.5-30)     | 7.6 (25)  | 12.2 (40)  | 114.3 (375) |                        | 182.9 (600)                   | 182.9 (600) | 182.9 (600)                   |             |            |             | 24.4 (80)                     | 182.9 (600) |             |             |             |
| C           | 30-45 (X40-X60)   | 30-45 (40-60)       | 7.6 (25)  | 12.2 (40)  | 114.3 (375) |                        | 182.9 (600)                   | 182.9 (600) | 182.9 (600)                   |             |            |             | 76.2 (250)                    | 182.9 (600) |             |             |             |
| D           | 45-112 (60-X150)  | 45-112 (60-150)     | 12.2 (40) | 30.5 (100) | 114.3 (375) |                        | 182.9 (600)                   | 182.9 (600) | 182.9 (600)                   |             |            |             | 61.0 (200)                    | 91.4 (300)  |             |             |             |
| E           | 112-187 (150-250) | 112-224 (150-300)   | 12.2 (40) | 53.3 (175) | 114.3 (375) |                        | 182.9 (600)                   | 182.9 (600) | 182.9 (600)                   |             |            |             | 182.9 (600)                   | 182.9 (600) |             |             |             |
| F           | 224-336 (300-450) | 224-336 (300-450)   | 18.3 (60) | 53.3 (175) | 114.3 (375) |                        | 182.9 (600)                   | 182.9 (600) | 182.9 (600)                   |             |            |             | 182.9 (600)                   | 182.9 (600) |             |             |             |
| G           | 224-448 (300-600) | 224-448 (300-600)   | 18.3 (60) | 53.3 (175) | 114.3 (375) |                        | 182.9 (600)                   | 182.9 (600) | 182.9 (600)                   |             |            |             | 182.9 (600)                   | 182.9 (600) |             |             |             |
| H           | 522-597 (700-800) | 522-597 (700-800)   | 18.3 (60) | 53.3 (175) | 114.3 (375) |                        | 182.9 (600)                   | 182.9 (600) | 182.9 (600)                   |             |            |             | 182.9 (600)                   | 182.9 (600) |             |             |             |

**Note**  
For applications/installations using new motors, no restrictions in lead length due to voltage reflection are necessary. You should observe standard practices for voltage drop, cable capacitance, and other issues. For retrofit situations, check with the motor manufacturer for insulation rating.

Use 1204-TFB2 Terminator

**Type A Motor Characteristics:** No phase paper or misplaced phase paper, lower quality insulation systems, corona inception voltages between 850 and 1000 volts.

**Type B Motor Characteristics:** Properly placed phase paper, medium quality insulation systems, corona inception voltages between 1000 and 1200 volts.

**1329R Motors:** These AC Variable Speed motors are "Power Matched" for use with Allen-Bradley Drives. Each motor is energy efficient and designed to meet or exceed the requirements of the Federal Energy Act of 1992. All 1329R motors are optimized for variable speed operation and include premium inverter grade insulation systems which meet or exceed NEMA MG1, Part 31.40.4.2.

# 1336 IMPACT AC Drive Pre-Installation

## Motor Cables

### Maximum Motor Cable Length Restrictions — 500V-600V Drives <sup>4</sup>

All cable lengths given in meters (feet)

| Drive Frame | Drive kW (HP)      | Motor kW (HP)      | No External Devices                 |           |                    | w/1204-TFB2 Terminator              |             |                    | w/1204-TFA1 Terminator              |            |                    | Reactor at Drive <sup>2</sup>       |             |                    |             |            |            |             |
|-------------|--------------------|--------------------|-------------------------------------|-----------|--------------------|-------------------------------------|-------------|--------------------|-------------------------------------|------------|--------------------|-------------------------------------|-------------|--------------------|-------------|------------|------------|-------------|
|             |                    |                    | Motor w/Insulation V <sub>p-p</sub> |           |                    | Motor w/Insulation V <sub>p-p</sub> |             |                    | Motor w/Insulation V <sub>p-p</sub> |            |                    | Motor w/Insulation V <sub>p-p</sub> |             |                    |             |            |            |             |
|             |                    |                    | 1000V                               | 1200V     | 1600V <sup>6</sup> | 1000V                               | 1200V       | 1600V <sup>6</sup> | 1000V                               | 1200V      | 1600V <sup>6</sup> | 1000V                               | 1200V       | 1600V <sup>6</sup> |             |            |            |             |
|             |                    |                    | Any Cable                           | Any Cable | Any Cable          | Any Cable                           | Any Cable   | Any Cable          | Any Cable                           | Any Cable  | Any Cable          | Any Cable                           | Any Cable   |                    |             |            |            |             |
| A4          | 0.75 (1)           | 0.75 (1)           | NR                                  | NR        | 15.2 (50)          | NR                                  | 182.9 (600) | 335.3 (1100)       | NR                                  | 61.0 (200) | 182.9 (600)        | Not Recommended                     |             |                    |             |            |            |             |
|             |                    | 0.37 (0.5)         | NR                                  | NR        | 15.2 (50)          | NR                                  | 182.9 (600) | 335.3 (1100)       | NR                                  | 61.0 (200) | 182.9 (600)        |                                     |             |                    |             |            |            |             |
|             |                    | 1.5 (2)            | NR                                  | NR        | 15.2 (50)          | NR                                  | 182.9 (600) | 335.3 (1100)       | NR                                  | 61.0 (200) | 182.9 (600)        |                                     |             |                    |             |            |            |             |
|             | 1.5 (2)            | 1.5 (2)            | NR                                  | NR        | 15.2 (50)          | NR                                  | 182.9 (600) | 335.3 (1100)       | NR                                  | 61.0 (200) | 182.9 (600)        |                                     |             |                    |             |            |            |             |
|             |                    | 1.2 (1.5)          | NR                                  | NR        | 15.2 (50)          | NR                                  | 182.9 (600) | 335.3 (1100)       | NR                                  | 61.0 (200) | 182.9 (600)        |                                     |             |                    |             |            |            |             |
|             |                    | 0.75 (1)           | NR                                  | NR        | 15.2 (50)          | NR                                  | 182.9 (600) | 335.3 (1100)       | NR                                  | 61.0 (200) | 182.9 (600)        |                                     |             |                    |             |            |            |             |
|             | 2.2 (3)            | 0.37 (0.5)         | NR                                  | NR        | 15.2 (50)          | NR                                  | 182.9 (600) | 335.3 (1100)       | NR                                  | 61.0 (200) | 182.9 (600)        |                                     |             |                    |             |            |            |             |
|             |                    | 2.2 (3)            | NR                                  | NR        | 15.2 (50)          | NR                                  | 182.9 (600) | 335.3 (1100)       | NR                                  | 61.0 (200) | 182.9 (600)        |                                     |             |                    |             |            |            |             |
|             |                    | 1.5 (2)            | NR                                  | NR        | 15.2 (50)          | NR                                  | 182.9 (600) | 335.3 (1100)       | NR                                  | 61.0 (200) | 182.9 (600)        |                                     |             |                    |             |            |            |             |
|             | 3.7 (5)            | 0.75 (1)           | NR                                  | NR        | 15.2 (50)          | NR                                  | 182.9 (600) | 335.3 (1100)       | NR                                  | 61.0 (200) | 182.9 (600)        |                                     |             |                    |             |            |            |             |
|             |                    | 0.37 (0.5)         | NR                                  | NR        | 15.2 (50)          | NR                                  | 182.9 (600) | 335.3 (1100)       | NR                                  | 61.0 (200) | 182.9 (600)        |                                     |             |                    |             |            |            |             |
|             |                    | 3.7 (5)            | NR                                  | NR        | 15.2 (50)          | NR                                  | 182.9 (600) | 335.3 (1100)       | NR                                  | 61.0 (200) | 182.9 (600)        |                                     |             |                    |             |            |            |             |
|             | B                  | 5.5-15 (7.5-20)    | 5.5-15 (7.5-20)                     | NR        | 9.1 (30)           | 15.2 (50)                           | 91.4 (300)  | 182.9 (600)        | 182.9 (600)                         | NR         | 61.0 (200)         |                                     |             |                    | 182.9 (600) | 30.5 (100) | 91.4 (300) | 182.9 (600) |
|             |                    |                    | 18.5-45 (25-60)                     | NR        | 9.1 (30)           | 12.2 (40)                           | 91.4 (300)  | 182.9 (600)        | 182.9 (600)                         | NR         | 61.0 (200)         |                                     |             |                    | 182.9 (600) | 30.5 (100) | 91.4 (300) | 182.9 (600) |
|             |                    |                    | 56-93 (75-125)                      | NR        | 9.1 (30)           | 33.5 (110)                          | 91.4 (300)  | 182.9 (600)        | 182.9 (600)                         | NR         | 61.0 (200)         |                                     |             |                    | 182.9 (600) | 61.0 (200) | 91.4 (300) | 182.9 (600) |
| E           | 112-224 (150-X300) | 112-224 (150-X300) | NR                                  | 9.1 (30)  | 21.3 (70)          | 91.4 (300)                          | 182.9 (600) | 182.9 (600)        | NR                                  | 61.0 (200) | 182.9 (600)        | 182.9 (600)                         | 182.9 (600) | 182.9 (600)        |             |            |            |             |
| F           | 224-336 (300-450)  | 224-336 (300-450)  | NR                                  | 9.1 (30)  | 41.1 (135)         | 91.4 (300)                          | 182.9 (600) | 182.9 (600)        | NR                                  | 61.0 (200) | 182.9 (600)        | 182.9 (600)                         | 182.9 (600) | 182.9 (600)        |             |            |            |             |
| G           | 224-448 (300-600)  | 224-448 (300-600)  | NR                                  | 9.1 (30)  | 41.1 (135)         | 91.4 (300)                          | 182.9 (600) | 182.9 (600)        | NR                                  | 61.0 (200) | 182.9 (600)        | 182.9 (600)                         | 182.9 (600) | 182.9 (600)        |             |            |            |             |
| H           | 522-597 (700-800)  | 522-597 (700-800)  | NR                                  | 9.1 (30)  | 41.1 (135)         | 91.4 (300)                          | 182.9 (600) | 182.9 (600)        | NR                                  | 61.0 (200) | 182.9 (600)        | 182.9 (600)                         | 182.9 (600) | 182.9 (600)        |             |            |            |             |

NR = Not Recommended

<sup>1</sup> Values shown are for 480V nominal input voltage and drive carrier frequency of 2 kHz. Consult factory regarding operation at carrier frequencies above 2 kHz. Multiply values by 0.85 for high line conditions. For input voltages of 380, 400 or 415V AC, multiply the table values by 1.25, 1.20 or 1.15, respectively.

<sup>2</sup> A 3% reactor reduces motor and cable stress but may cause a degradation of motor waveform quality. Reactors must have a turn-turn insulation rating of 2100 volts or higher.

<sup>3</sup> Includes wire in conduit.

<sup>4</sup> Values shown are for nominal input voltage and drive carrier frequency of 2 kHz. Consult factory regarding operation at carrier frequencies above 2 kHz. Multiply values by 0.85 for high line conditions.

<sup>5</sup> Information not available at time of printing.

<sup>6</sup> 1329R only.

<sup>7</sup> These distance restrictions are due to charging of cable capacitance and may vary from application to application.

# 1336 IMPACT AC Drive Pre-Installation

## Output Devices

### Common Mode Cores

Common mode cores will help reduce the common mode noise at the drive output and guard against nuisance tripping of the drive caused by capacitive leakage effects. The capacitive currents are larger at higher PWM carrier frequencies. Refer to the table on **Page 59**.

## Cable Termination

### Optional Output Reactor

The reactors listed on **Page 59** can be used for drive input and output. These reactors are specifically constructed to accommodate IGBT inverter applications with switching frequencies up to 20 kHz. They have a UL approved dielectric strength of 4000 volts, opposed to a normal rating of 2500 volts. The first two and last two turns of each coil are triple insulated to guard against insulation breakdown resulting from high dv/dt. When using motor line reactors, it is recommended that the drive PWM frequency be set to its lowest value to minimize losses in the reactors.

**Important:** By using an output reactor the effective motor voltage will be lower because of the voltage drop across the reactor — This may also mean a reduction of motor torque.

### Optional Cable Terminator

Voltage doubling at motor terminals, known as reflected wave phenomenon, standing wave or transmission line effect, can occur when using drives with long motor cables.

Inverter duty motors with phase-to-phase insulation ratings of 1200 volts or higher should be used to minimize effects of reflected wave on motor insulation life.

Applications with non-inverter duty motors or any motor with exceptionally long leads may require an output inductor or cable terminator. An inductor or terminator will help limit reflection to the motor, to levels which are less than the motor insulation rating.

Maximum recommended cable lengths for unterminated cables are listed on the previous page since the voltage doubling phenomenon occurs at different lengths for different drive ratings. If your installation requires longer motor cable lengths, a cable terminator or one of the line reactors listed on **Page 59** only is recommended.

**Important:** Terminator Cat. No. 1204-TFB2 carries the following restrictions – at any kW (HP) rating, the maximum drive carrier frequency = 2kHz, and the maximum cable run is 183 meters (600 feet).

## Control Interface Wiring — TB3

User control interface inputs are connected through TB3 on the L4/L7E, L5/L8E and L6/L9E Option Boards. Each board has nine control inputs. The function of each input must be selected through programming.

A variety of combinations made up of the following inputs are available.

|                                    |                            |                            |                       |
|------------------------------------|----------------------------|----------------------------|-----------------------|
| <b>Start</b>                       | <b>2 Accel/Decel Rates</b> | <b>2 Stop Mode Selects</b> | <b>3 Speed/Torque</b> |
| <b>Stop/Clear Fault</b>            | <b>3 Speed Selects</b>     | <b>Run Forward</b>         | <b>Selects</b>        |
| <b>Forward/Reverse</b>             | <b>Enable</b>              | <b>Run Reverse</b>         | <b>Ramp Disable</b>   |
| <b>Digital Potentiometer (MOP)</b> | <b>Reset</b>               | <b>Local Control</b>       |                       |
| <b>Process Trim</b>                | <b>Jog</b>                 | <b>Flux Enable</b>         |                       |



**ATTENTION:** The drive is intended to be controlled by control input signals that will start and stop the motor. A device that routinely disconnects then reapplies line power to the drive for the purpose of starting and stopping the motor *IS NOT* recommended. If this type of circuit is used, a maximum of 3 stops in any 5-minute period with a minimum 1 minute rest between each cycle is required. These 5-minute periods must be separated by 10-minute rest cycles to allow the drive precharge resistors to cool. Refer to codes and standards applicable to your particular system for specific requirements and additional information.

# 1336 IMPACT AC Drive Pre-Installation

## Control Interface Wiring — TB3

### Maximum and Minimum Wire Size

The maximum and minimum wire size accepted by TB3 is 2.1 and 0.30 mm<sup>2</sup> (14 and 22 AWG). Maximum torque for all terminals is 1.36 N-m (12 lb-in).

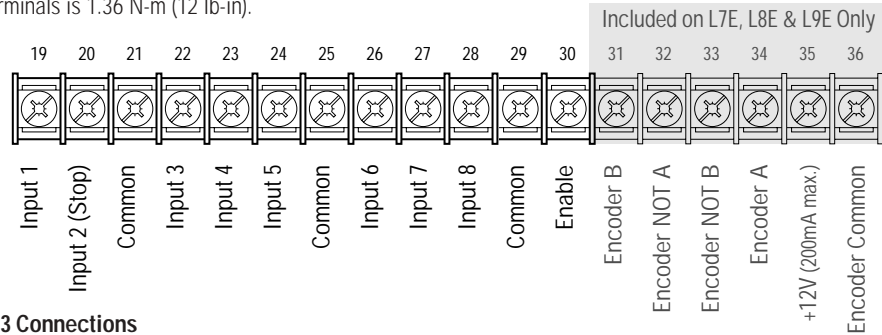

### Input Mode Selection and Typical TB3 Connections

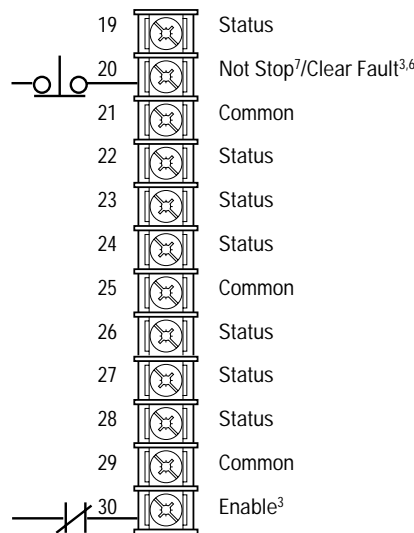

**Input Mode (parameter 102) = 1**  
Factory Default

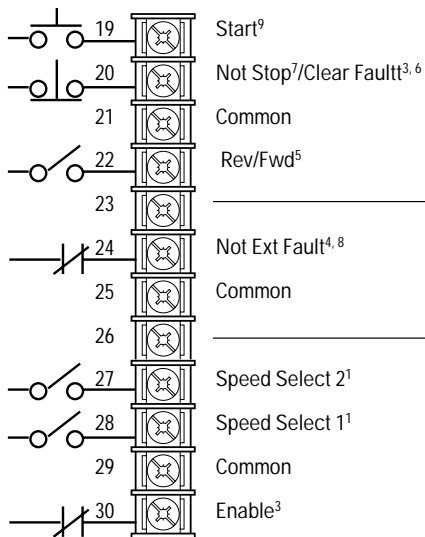

**Input Mode (parameter 102) = 2-6, 17, 18, and 27**  
Single-Source, Three-Wire Control

| Mode | 2                           | 3                           | 4             | 5 <sup>10</sup> | 6                          | 17           | 18          | 27 <sup>10</sup> |
|------|-----------------------------|-----------------------------|---------------|-----------------|----------------------------|--------------|-------------|------------------|
|      | Jog                         | Stop Type <sup>7</sup>      | 2nd/1st Accel | Digital Pot UP  | Jog                        | Process Trim | Flux Enable | Digital Pot UP   |
|      | Speed Select 3 <sup>1</sup> | Speed Select 3 <sup>1</sup> | 2nd/1st Decel | Digital Pot Dn  | Local Control <sup>2</sup> | Ramp         | Reset       | Digital Pot Dn   |

<sup>1</sup> See Speed Select Table.

<sup>2</sup> Drive must be stopped to take Local Control. Control by all other adapters is disabled (except Stop).

<sup>3</sup> These inputs must be present before drive will start.

<sup>4</sup> For Common Bus, this becomes Precharge Enable.

<sup>5</sup> Bit 11 of Logic Options (parameter 17) must be 0 for reverse direction control.

<sup>6</sup> For soft faults only. You need to recycle power to the drive or reset to clear hard faults. For hard faults, refer to the troubleshooting chapter.

<sup>7</sup> To configure the stop type, refer to Logic Options (parameter 17).

<sup>8</sup> This input must be present before the fault can be cleared and the drive will start. This can be disabled through Fault Select 2 (parameter 22) and Warning Select (parameter 23).

<sup>9</sup> To configure the start type, refer to Logic Options (parameter 17). Latched (momentary) starts require a stop to stop the drive.

<sup>10</sup> In Mode 5, the MOP value is not reset to zero when you stop. In Mode 7 the MOP value is reset to zero when you stop.

## Control Interface Wiring — TB3

### Input Mode Selection and Typical TB3 Connections

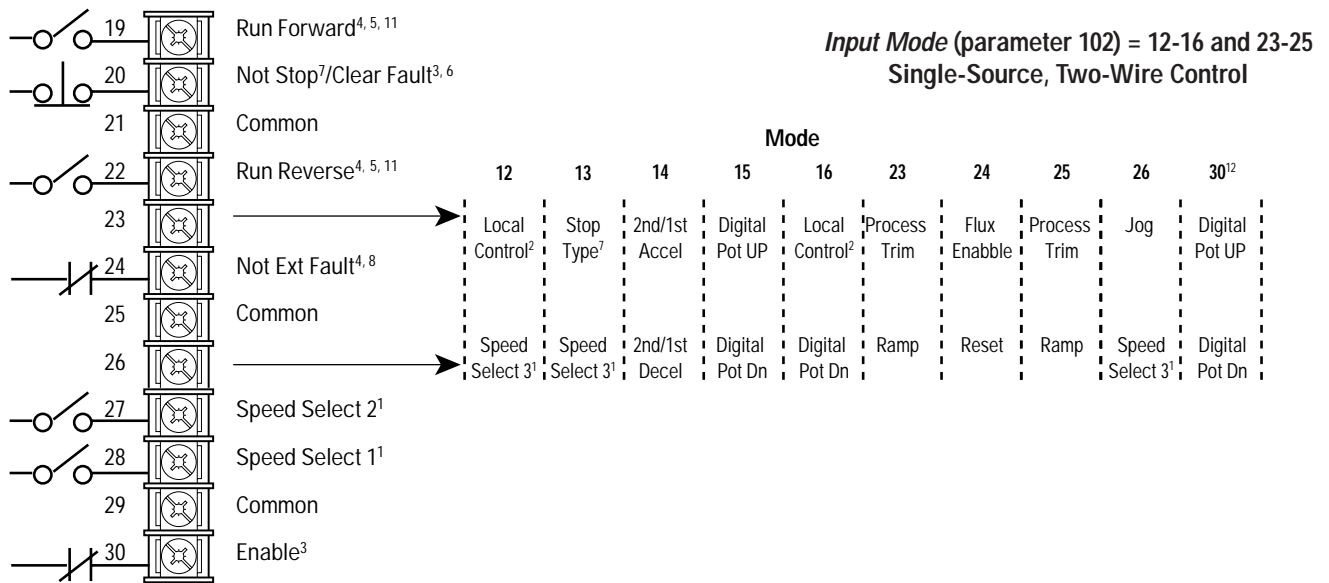
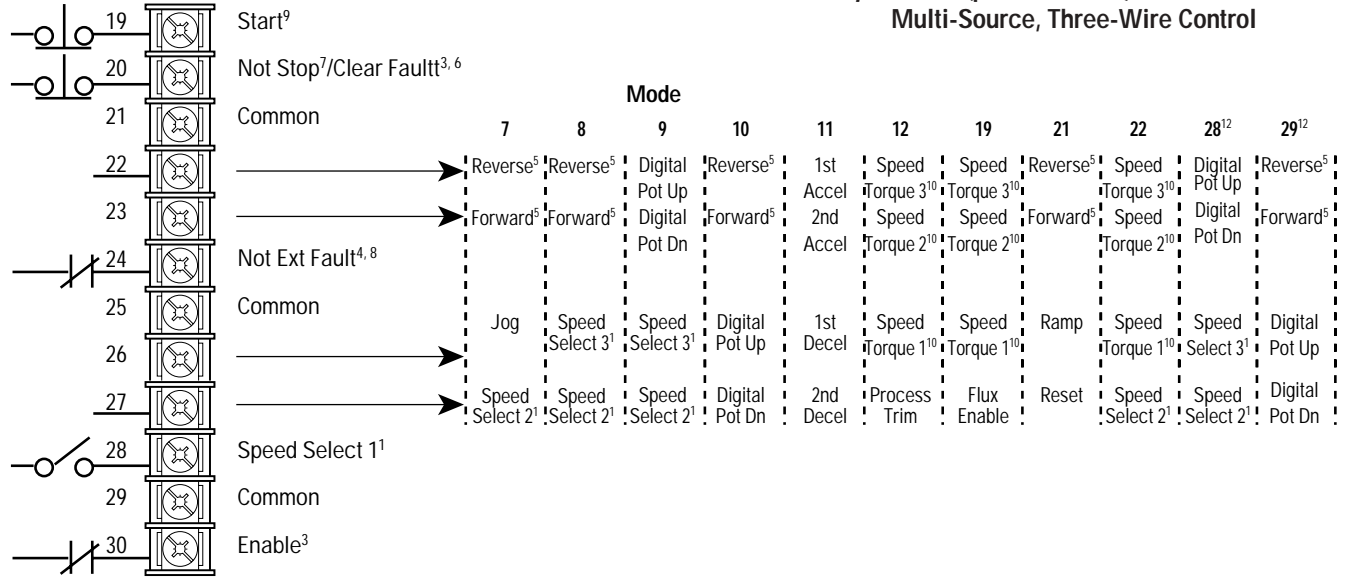

<sup>1</sup> See Speed Select Table.

<sup>2</sup> Drive must be stopped to take Local Control. Control by all other adapters is disabled (except Stop).

<sup>3</sup> These inputs must be present before drive will start.

<sup>4</sup> For Common Bus, this becomes Precharge Enable.

<sup>5</sup> Bit 12 of Logic Options (parameter 17) must be 0 for reverse direction control.

<sup>6</sup> For soft faults only. You need to recycle power to the drive or reset to clear hard faults. For hard faults, refer to the troubleshooting chapter.

<sup>7</sup> To configure the stop type, refer to Logic Options (parameter 17).

<sup>8</sup> This input must be present before the fault can be cleared and the drive will start. This can be disabled through Fault Select 2 (parameter 22) and Warning Select 2 (parameter 23).

<sup>9</sup> To configure the start type, refer to Logic Options (parameter 17).

<sup>10</sup> See Speed/Torque Select table.

<sup>11</sup> Unlatched (maintained) start.

<sup>12</sup> In Modes 9, 10, and 15, the MOP value is not reset to 0 when you stop. In Modes 28, 29, and 30, the MOP value is reset to 0 when you stop.

# 1336 IMPACT AC Drive Pre-Installation

## Control & Signal Wiring Frames A1, A2, A3 and A4

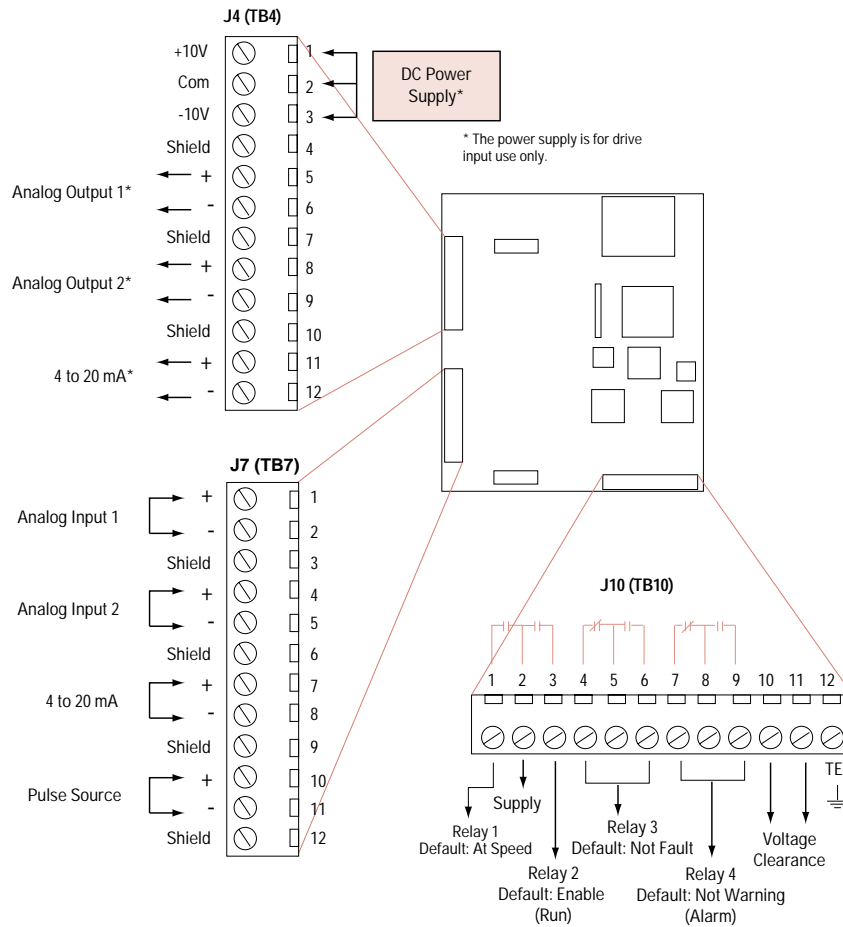

| Terminal Block | Terminal Number(s) | Signal                              |                                                                                                                          |
|----------------|--------------------|-------------------------------------|--------------------------------------------------------------------------------------------------------------------------|
| TB4            | 4, 7, 10           | Shield Ground                       |                                                                                                                          |
|                | 1,2,3              | DC Power Supply                     | +/- 10V DC<br>50 mA per voltage                                                                                          |
|                | 5, 6, 8, 9         | 0 to +/- 10V DC output:             | Output Impedance = 100 Ohms;<br>10 mA maximum                                                                            |
|                | 11, 12             | 4-20 mA DC output:                  | Output Impedance = 20 Ohms                                                                                               |
| TB7            | 3, 6, 9, 12        | Shield Ground                       |                                                                                                                          |
|                | 1, 2, 4, 5         | 0 to +/- 10V DC input:              | Input Impedance = 20k Ohms                                                                                               |
|                | 7, 8               | 4-20 mA input                       | Input Impedance = 130 Ohms                                                                                               |
|                | 10, 11             | Pulse input for frequency reference | +5V DC — Jumper J8 Set to 1-2<br>+12V DC — Jumper J8 Set to 2-3<br>Scale Factor (Pulse PPR) must be set<br>10 mA minimum |
| TB10           | 12                 | Logic Earth Ground, Shield          |                                                                                                                          |
|                | 1, 2, 3            | Programmable Contacts               |                                                                                                                          |
|                | 4,5,6              | Fault Contact                       | Resistive Rating = 115V AC/30V DC, 5.0A<br>Inductive Rating = 115V AC/30V DC, 2.0A                                       |
|                | 7, 8, 9            | Alarm Contact                       | Resistive Rating = 115V AC/30V DC, 5.0A<br>Inductive Rating = 115V AC/30V DC, 2.0A                                       |
|                | 10, 11             | Voltage Clearance                   | Provides physical space between the logic<br>earth ground and other signals on the<br>terminal block.                    |

**\*Attention:** Analog I/O is Differential, Non-isolated I/O. Specifically, connecting the 4-20 mA output of the drive to a non-isolated input of another device may result in a drive component failure.

# 1336 IMPACT AC Drive Pre-Installation

## Control & Signal Wiring Frames B, C, D, E, F, G and H

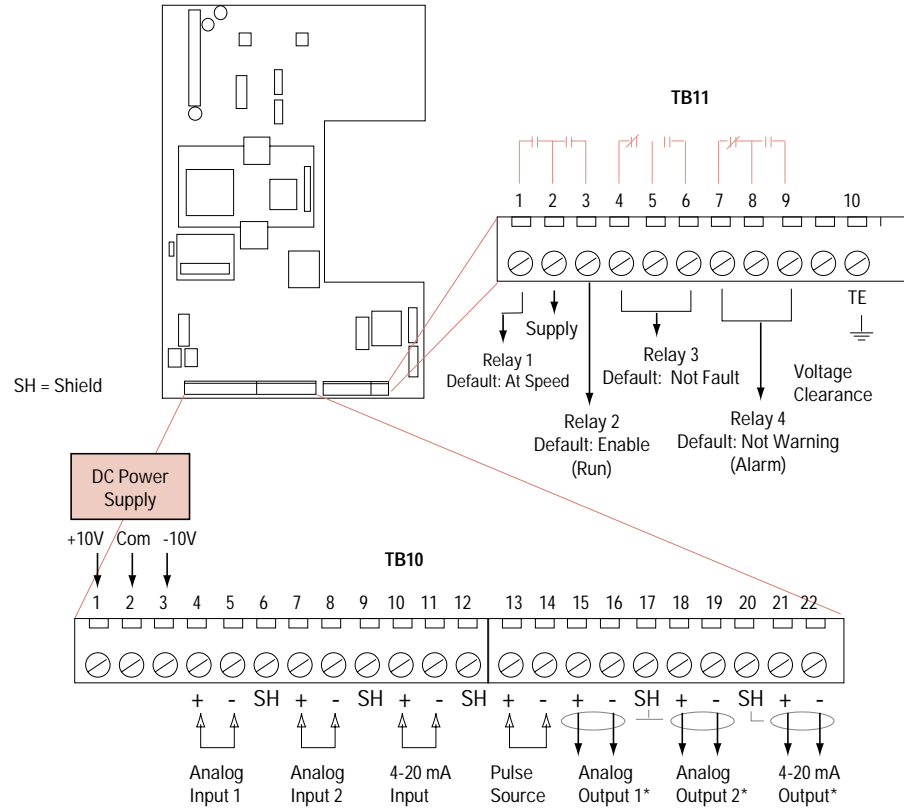

| Terminal Block | Terminal Number(s) | Signal                          |                                                                                                                          |
|----------------|--------------------|---------------------------------|--------------------------------------------------------------------------------------------------------------------------|
| TB10           | 6, 9, 12, 17, 20   | Shield Ground                   |                                                                                                                          |
|                | 1,2,3              | DC Power Supply                 | +/- 10V DC<br>50 mA per voltage                                                                                          |
|                | 4, 5, 7, 8         | 0 to +/- 10V DC input:          | Input Impedance = 20k Ohms                                                                                               |
|                | 10, 11             | 4-20 mA Input:                  | Input Impedance = 130 Ohms                                                                                               |
|                | 13,14              | Pulse Input for frequency ref.: | +5V DC — Jumper J4 Set to 1-2<br>+12V DC — Jumper J4 Set to 2-3<br>Scale Factor (Pulse PPR) must be set<br>10 mA minimum |
|                | 15, 16, 18, 19     | 0 to ±10V DC output             | Output impedance = 100 Ohms;<br>10 mA maximum                                                                            |
|                | 21, 22             | 4-20 mA DC output               | Output impedance = 20 Ohms                                                                                               |
| TB11           | 10                 | Logic Earth Ground, Shield      |                                                                                                                          |
|                | 1, 2, 3            | Programmable Contacts           |                                                                                                                          |
|                | 4, 5, 6            | Fault Contact                   | Resistive Rating = 115V AC/30V DC, 5.0A<br>Inductive Rating = 115V AC/30V DC, 2.0A                                       |
|                | 7, 8, 9            | Alarm Contact                   | Resistive Rating = 115V AC/30V DC, 5.0A<br>Inductive Rating = 115V AC/30V DC, 2.0A                                       |

**\*Attention:** Analog I/O is Differential, Non-isolated I/O. Specifically, connecting the 4-20 mA output of the drive to a non-isolated input of another device may result in a drive component failure.

# 1336 IMPACT AC Drive Pre-Installation

## Customer Supplied Enclosures

### Requirements

- 1 Base Derate Amps are based on nominal voltage (240, 480 or 600V). If input voltage exceeds Drive Rating, Drive Output must be derated. Refer to **Figure 40**.
- 2 Drive Ambient Temperature Rating is 40°C. If ambient exceeds 40°C, the drive must be derated. Refer to **Figures 1-38**.
- 3 Drive Rating is based on altitudes of 1,000 m (3,000 ft.) or less. If installed at higher altitude, drive must be derated. Refer to **Figure 39**.
- 4 Not available at time of publication.
- 5 **Important:** Two (2) 725 CFM fans are required if an open type drive is mounted in a user supplied enclosure.
- 6 This is the inverter loss only, common bus configuration 2kHz PWM.
- 7 This is the inverter loss only, common bus configuration 1kHz PWM.
- 8 **Important:** 1336E-BPRXXX drives require two (2) fans capable of producing greater than 450 CFM. One (1) fan open type drive is mounted in a user-supplied enclosure.
- 9 Rating is at 4kHz (2kHz for 224-448 kW/ 300-600 HP, 500-600V). If carrier frequencies above 4kHz are selected, drive rating must be derated. Refer to **Figures 1-40**.
- 10 Due to drive losses, the output voltage to the motor is affected by the AC input voltage to the drive. This reduced motor voltage may require more motor torque, and therefore current, to achieve rated motor horsepower. Though most applications do not require full rated motor horsepower at full speed, the following information is provided to assist with proper motor/drive selection.
  - A. For 460V motors, operate with a minimum 480V Input AC line voltage.
  - B. Size the motor with the capability to operate with 8% more current.
  - C. Purchase a motor designed to operate at 440V.

**Note:** For items B and C above, make sure the drive current rating is adequate to support the motor.  
Refer to **Figure 41**.

1336 IMPACT AC drives installed in your enclosures may be mounted within an enclosure or may be mounted to allow the heatsink to extend outside the enclosure. Use the information below in combination with the enclosure manufacturer's guidelines for sizing.

### 200-240V DRIVES

| Cat No.10 | Base Derate Amps 1 | Derate Curve 2, 3 | Heat Dissipation Drive Watts 2, 3, 9 | Heatsink Watts 9 | Total Watts 9 |
|-----------|--------------------|-------------------|--------------------------------------|------------------|---------------|
| AQF05     | 2.3                | Figure 1          | 13                                   | 15               | 28            |
| AQF07     | 3.0                | Figure 1          | 15                                   | 21               | 36            |
| AQF10     | 4.5                | Figure 1          | 17                                   | 32               | 49            |
| AQF15     | 6.0                | Figure 1          | 21                                   | 42               | 63            |
| AQF20     | 8.0                | Figure 1          | 25                                   | 56               | 81            |
| AQF30     | 12.0               | Figure 1          | 33                                   | 72               | 105           |
| AQF50     | 18.0               | Figure 1          | 42                                   | 116              | 158           |
| A007      | 27.2               | NONE              | 156                                  | 486              | 642           |
| A010      | 33.7               | Figure 2          | 200                                  | 721              | 921           |
| A015      | 48.2               | Figure 3          | 205                                  | 819              | 1024          |
| A020      | 64.5               | Figure 4          | 210                                  | 933              | 1143          |
| A025      | 78.2               | Figure 5          | 215                                  | 1110             | 1325          |
| A030      | 80                 | NONE              | 220                                  | 1110             | 1330          |
| A040      | 120.3              | Figure 6          | 361                                  | 1708             | 2069          |
| A050      | 149.2              | Figure 7          | 426                                  | 1944             | 2370          |
| A060      | 180.4              | Figure 8          | 522                                  | 2664             | 3186          |
| A075      | 240                | Figure 9          | 606                                  | 2769             | 3375          |
| A100      | 291.4              | Figure 10         | 755                                  | 3700             | 4455          |
| A125      | 325                | Figure 17         | 902                                  | 4100             | 5002          |

### 380-480V DRIVES

| Cat No.10              | Base Derate Amps 1 | Derate Curve 2, 3 | Heat Dissipation Drive Watts 2, 3, 9 | Heatsink Watts 9   | Total Watts 9 |
|------------------------|--------------------|-------------------|--------------------------------------|--------------------|---------------|
| BRF05                  | 1.2                | Figure 1          | 12                                   | 9                  | 21            |
| BRF07                  | 1.7                | Figure 1          | 13                                   | 15                 | 28            |
| BRF10                  | 2.3                | Figure 1          | 15                                   | 20                 | 35            |
| BRF15                  | 3.0                | Figure 1          | 16                                   | 27                 | 43            |
| BRF20                  | 4.0                | Figure 1          | 19                                   | 36                 | 55            |
| BRF30                  | 6.0                | Figure 1          | 23                                   | 54                 | 77            |
| BRF50                  | 9.0                | Figure 1          | 29                                   | 84                 | 113           |
| BRF75                  | 17.5               | Figure 1          | 70                                   | 230                | 300           |
| BRF100                 | 25                 | Figure 1          | 89                                   | 331                | 420           |
| B015                   | 27.2               | Figure 11         | 117                                  | 486                | 603           |
| B020                   | 33.7               | Figure 2          | 140                                  | 628                | 768           |
| B025                   | 41.8               | Figure 12         | 141                                  | 720                | 861           |
| B030                   | 48.2               | Figure 3          | 141                                  | 820                | 961           |
| BX040                  | 58.7               | Figure 13         | 175                                  | 933                | 1108          |
| B040                   | 64.5               | Figure 4          | 175                                  | 933                | 1108          |
| B050                   | 78.2               | Figure 5          | 193                                  | 1110               | 1303          |
| BX060                  | 78.2               | Figure 5          | 193                                  | 1110               | 1303          |
| B060                   | 96.9               | NONE              | 361                                  | 1708               | 2069          |
| B075                   | 120.3              | Figure 14         | 361                                  | 1708               | 2069          |
| B100                   | 149.2              | Figure 15         | 426                                  | 1944               | 2370          |
| B125                   | 180.4              | Figure 16         | 522                                  | 2664               | 3186          |
| BX150                  | 180.4              | Figure 16         | 606                                  | 2769               | 3375          |
| B150                   | 240                | Figure 9          | 606                                  | 2769               | 3375          |
| B200                   | 292.4              | Figure 10         | 755                                  | 3700               | 4455          |
| B250                   | 327.4              | Figure 17         | 902                                  | 4100               | 5002          |
| B300 <sup>5</sup>      | 406.4              | NONE              | 1005                                 | 4805               | 5810          |
| BP/BPR300 <sup>8</sup> | 357                | Figure 18         | 619                                  | 5342               | 5961          |
| B350 <sup>5</sup>      | 459.2              | NONE              | 1055                                 | 5455               | 6510          |
| BP/BPR350 <sup>8</sup> | 421                | Figure 19         | 733                                  | 6039               | 6772          |
| B400 <sup>5</sup>      | 505.1              | NONE              | 1295                                 | 6175               | 7470          |
| BP/BPR400 <sup>8</sup> | 471                | Figure 20         | 793                                  | 6329               | 7122          |
| B450 <sup>5</sup>      | 570.2              | NONE              | 1335                                 | 6875               | 8210          |
| BP/BPR450 <sup>8</sup> | 527                | Figure 21         | 931                                  | 7000               | 7931          |
| B500 <sup>5</sup>      | 599.2              | Figure 22         | 1400                                 | 7800               | 9200          |
| B600 <sup>5</sup>      | 673.4              | Figure 23         | 1485                                 | 8767               | 10252         |
| B700C                  | 850                | Figure 37         | 1700 <sup>6</sup>                    | 9700 <sup>6</sup>  | 11400         |
| B800C                  | 983                | Figure 37         | 1900 <sup>6</sup>                    | 12000 <sup>6</sup> | 13900         |

### 500-600V DRIVES

| Cat No.10         | Base Derate Amps 1 | Derate Curve 2, 3 | Heat Dissipation Drive Watts 2, 3, 9 | Heatsink Watts 9   | Total Watts 9 |
|-------------------|--------------------|-------------------|--------------------------------------|--------------------|---------------|
| CWF10             | 2.5                | Figure 24         | 25                                   | 29                 | 54            |
| CWF20             | 4.2                | Figure 24         | 29                                   | 57                 | 86            |
| CWF30             | 6                  | Figure 24         | 32                                   | 87                 | 119           |
| CWF50             | 7.9                | Figure 24         | 35                                   | 117                | 152           |
| CWF75             | 10                 | Figure 24         | 91                                   | 217                | 308           |
| CWF100            | 12                 | Figure 24         | 103                                  | 251                | 354           |
| C015              | 18.9               | NONE              | 117                                  | 360                | 477           |
| C020              | 23.6               | NONE              | 140                                  | 467                | 607           |
| C025              | 30                 | NONE              | 141                                  | 492                | 633           |
| C030              | 34.6               | NONE              | 141                                  | 526                | 667           |
| C040              | 45.1               | NONE              | 175                                  | 678                | 853           |
| C050              | 57.2               | NONE              | 193                                  | 899                | 1092          |
| C060              | 61.6               | NONE              | 193                                  | 981                | 1174          |
| C075              | 85.8               | Figure 25         | 361                                  | 1533               | 1894          |
| C100              | 109.1              | Figure 26         | 426                                  | 1978               | 2504          |
| C125              | 138.6              | Figure 27         | 522                                  | 2162               | 2683          |
| C150              | 159.7              | Figure 28         | 606                                  | 2315               | 2921          |
| C200              | 252.5              | Figure 29         | 755                                  | 3065               | 3820          |
| C250              | 283.6              | Figure 30         | 890                                  | 3625               | 4515          |
| C300 <sup>5</sup> | 298                | NONE              | 926                                  | 5015               | 5941          |
| CX300             | 298                | NONE              | 940                                  | 3990               | 4930          |
| C350 <sup>5</sup> | 353.6              | NONE              | 1000                                 | 5935               | 6935          |
| CP/CPR350         | 350                | Figure 31         | 580                                  | 6125               | 6705          |
| C400 <sup>5</sup> | 406.4              | Figure 32         | 1430                                 | 7120               | 8550          |
| CP/CPR400         | 400                | Figure 33         | 711                                  | 7000               | 7711          |
| C500 <sup>5</sup> | 505.1              | Figure 34         | 1500                                 | 8925               | 10425         |
| C600 <sup>5</sup> | 599.2              | Figure 35         | 1610                                 | 10767              | 12377         |
| C650 <sup>5</sup> | 673.4              | Figure 36         | 1700                                 | 12000              | 14000         |
| C700C             | 770                | Figure 37         | 1800                                 | 9400 <sup>7</sup>  | 11200         |
| C800C             | 850                | Figure 38         | 2000                                 | 11300 <sup>7</sup> | 13300         |

## Derating Guidelines

Drive ratings can be affected by a number of factors. If more than one factor exists, consult Allen-Bradley Company.

— Standard Rating for Enclosed Drive in 40°C Ambient & Open Drive in 50°C Ambient.
 - - - Derating Factor for Enclosed Drive in Ambient between 41°C & 50°C.

**Figure 1**  
1336E-AQF05-AQF50 and BRF05-BRF100

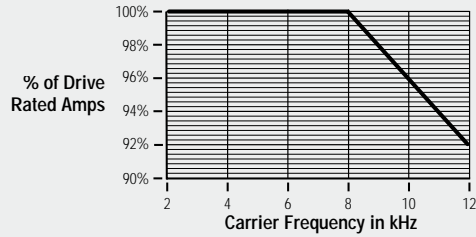

**Figure 2**  
1336E-A010 and B020

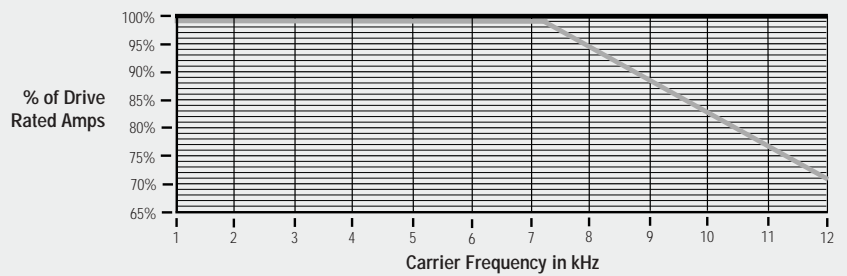

**Figure 3**  
1336E-A015 and B030

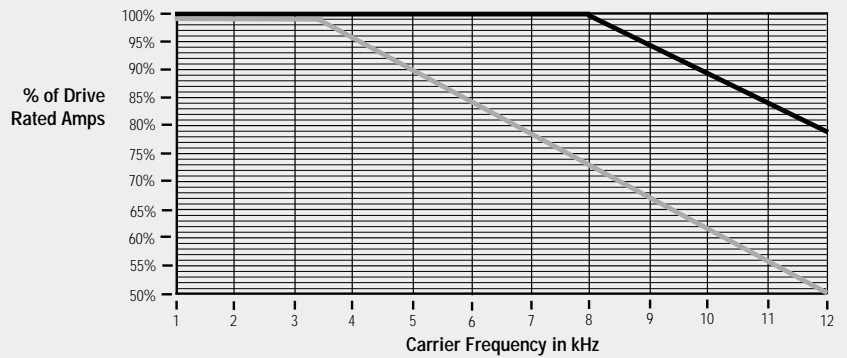

**Figure 4**  
1336E-A020 and B040

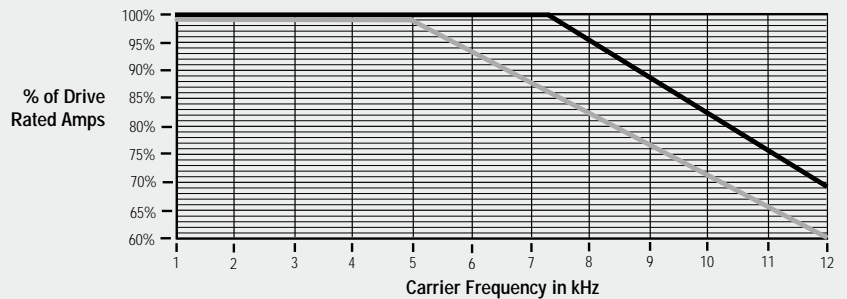

**Figure 5**  
1336E-A025, B050 and BX060

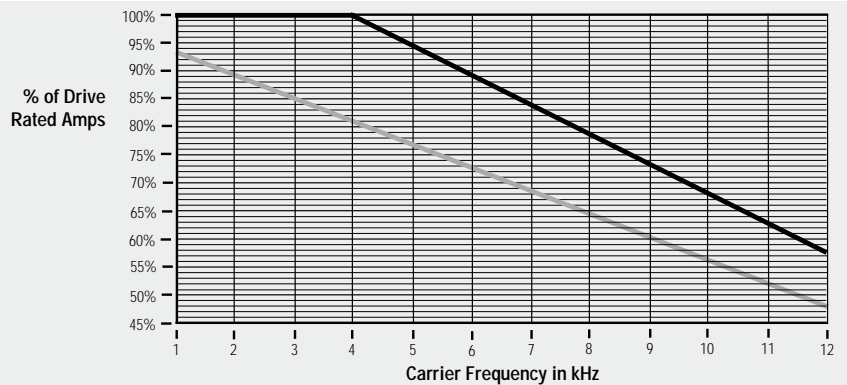

# 1336 IMPACT AC Drive Pre-Installation

## Derating Guidelines

Standard Rating for Enclosed Drive in 40°C Ambient & Open Drive in 50°C Ambient.
  Derating Factor for Enclosed Drive in Ambient between 41°C & 50°C.

**Figure 6**  
1336E-A040

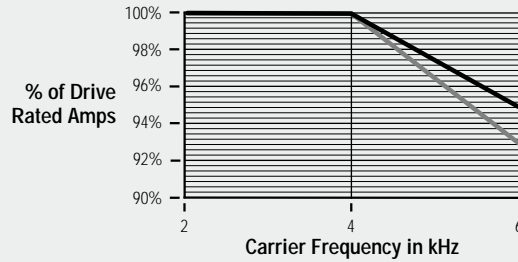

**Figure 7**  
1336E-A050

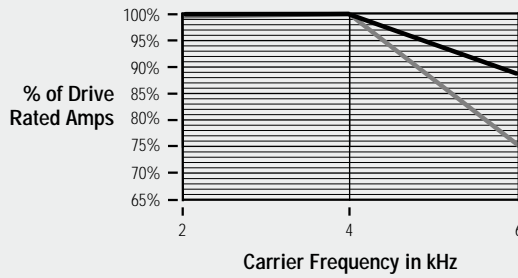

**Figure 8**  
1336E-A060

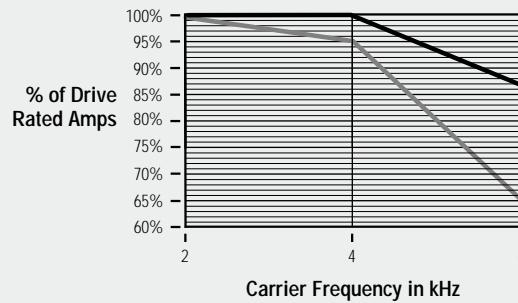

**Figure 9**  
1336E-A075 and B150

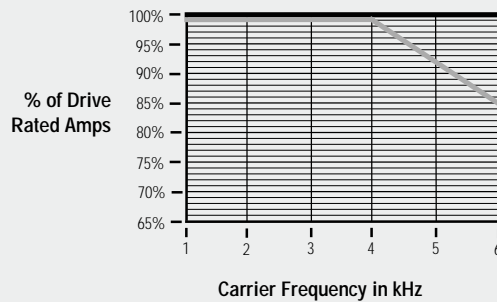

## Derating Guidelines

— Standard Rating for Enclosed Drive in 40°C Ambient & Open Drive in 50°C Ambient.
 — Derating Factor for Enclosed Drive in Ambient between 41°C & 50°C.

**Figure 10**  
1336E-A100 and B200

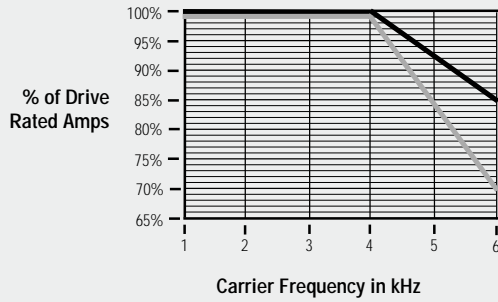

**Figure 11**  
1336E-B015

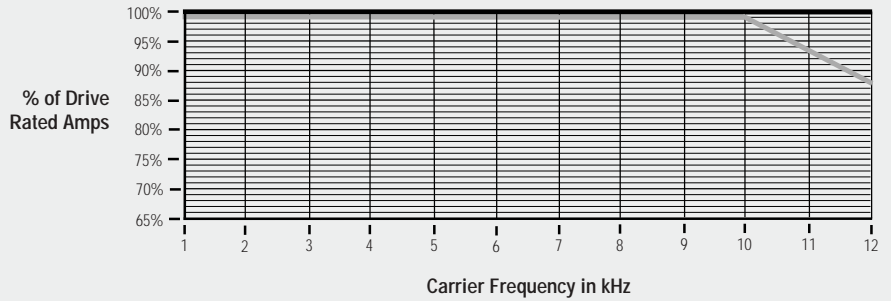

**Figure 12**  
1336E-B025

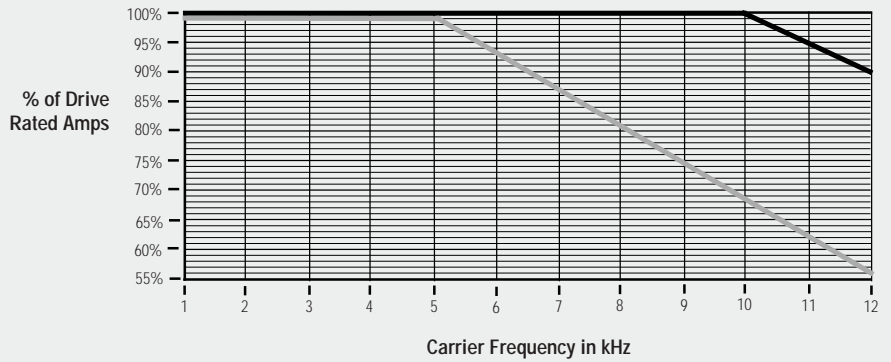

**Figure 13**  
1336E-BX040

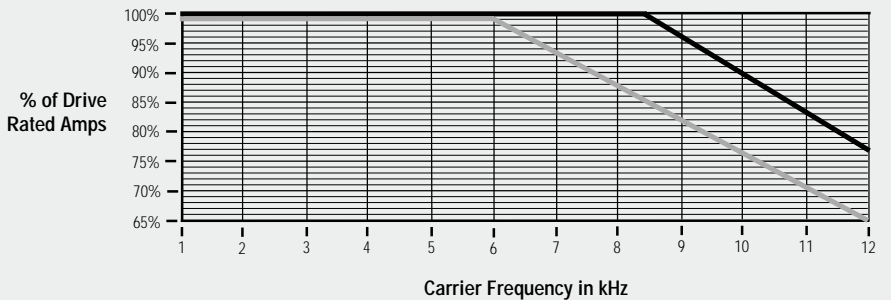

# 1336 IMPACT AC Drive Pre-Installation

## Derating Guidelines

— Standard Rating for Enclosed Drive in 40°C Ambient & Open Drive in 50°C Ambient.
 — Derating Factor for Enclosed Drive in Ambient between 41°C & 50°C.

**Figure 14**  
1336E-B075

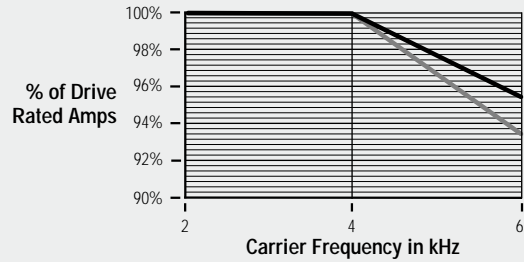

**Figure 15**  
1336E-B100

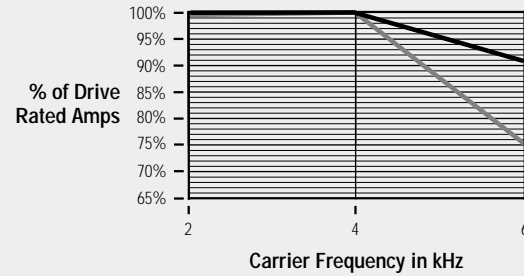

**Figure 16**  
1336E-B125 and BX150

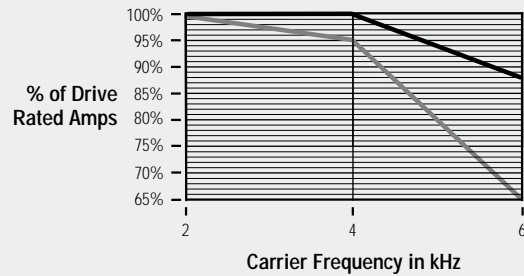

**Figure 17**  
1336E-A125 and B250

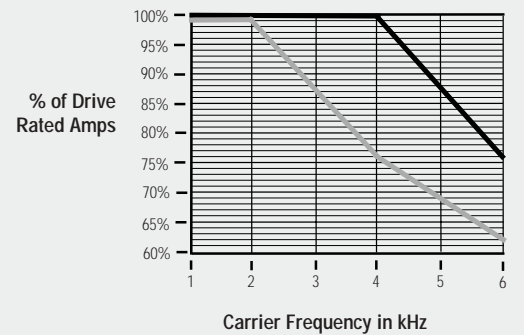

## Derating Guidelines

— Standard Rating for Enclosed Drive in 40°C Ambient & Open Drive in 50°C Ambient.
 — Derating Factor for Enclosed Drive in Ambient between 41°C & 50°C.

**Figure 18**  
1336E-BP300 and BPR300

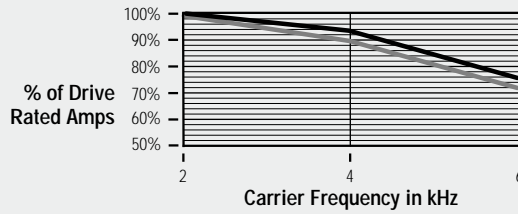

**Figure 19**  
1336E-BP350 and BPR350

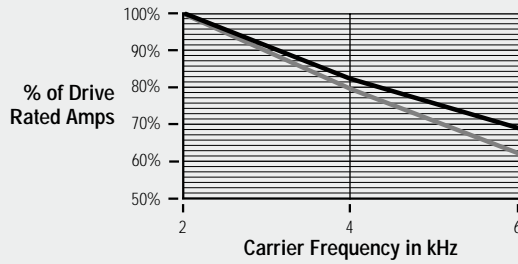

**Figure 20**  
1336E-BP400 and BPR400

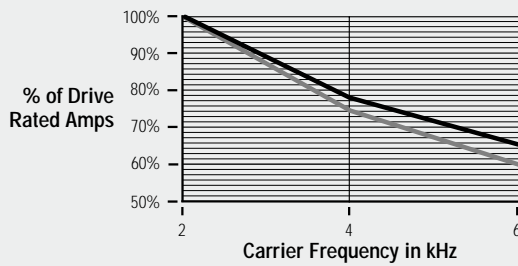

**Figure 21**  
1336E-BP450 and BPR450

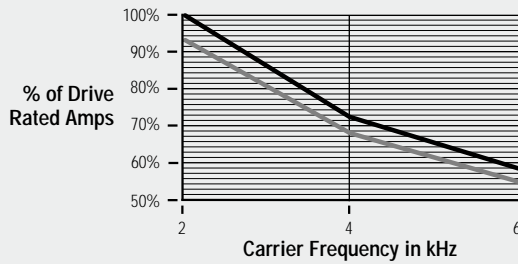

# 1336 IMPACT AC Drive Pre-Installation

## Derating Guidelines

Standard Rating for Enclosed Drive in 40°C Ambient & Open Drive in 50°C Ambient.
  Derating Factor for Enclosed Drive in Ambient between 41°C & 50°C.

**Figure 22**  
1336E-B500

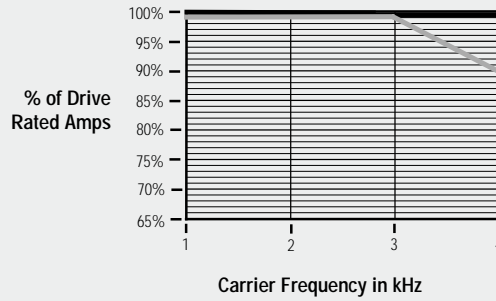

**Figure 23**  
1336E-B600

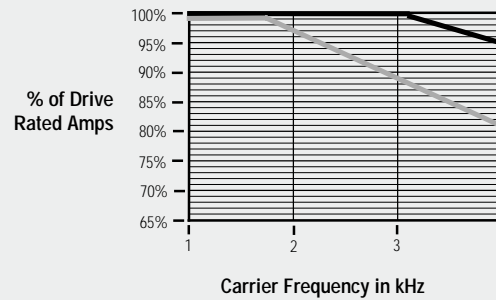

**Figure 24**  
1336E-CWF10 through CWF100

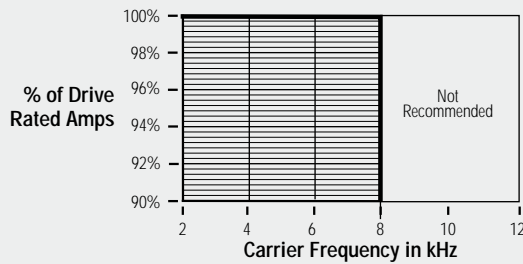

**Figure 25**  
1336E-C075

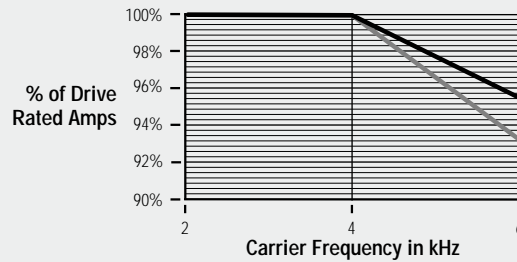

**Figure 26**  
1336E-C100

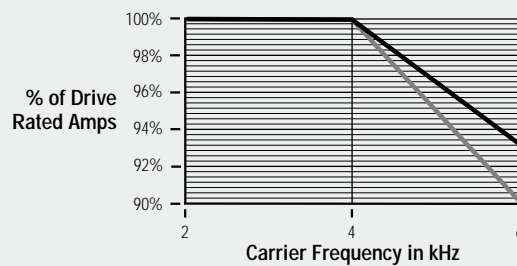

## Derating Guidelines

— Standard Rating for Enclosed Drive in 40°C Ambient & Open Drive in 50°C Ambient.
 — Derating Factor for Enclosed Drive in Ambient between 41°C & 50°C.

**Figure 27**  
1336E-C125

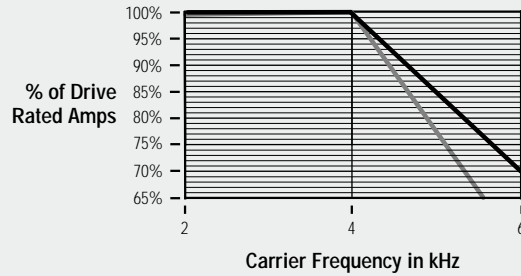

**Figure 28**  
1336E-C150

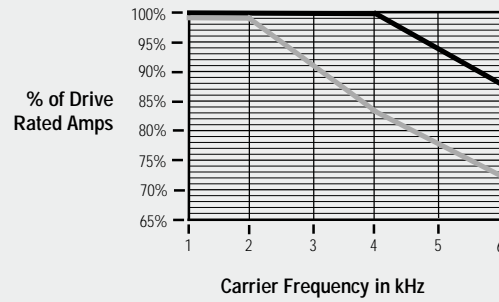

**Figure 29**  
1336E-C200

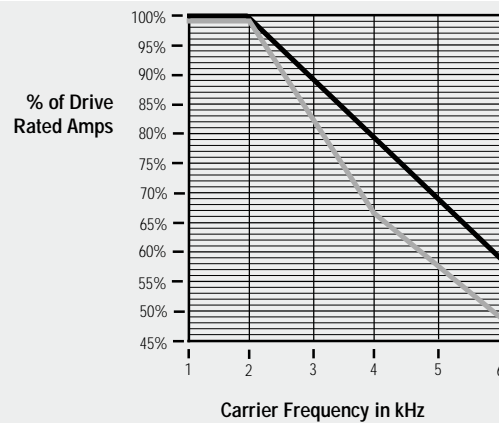

**Figure 30**  
1336E-C250

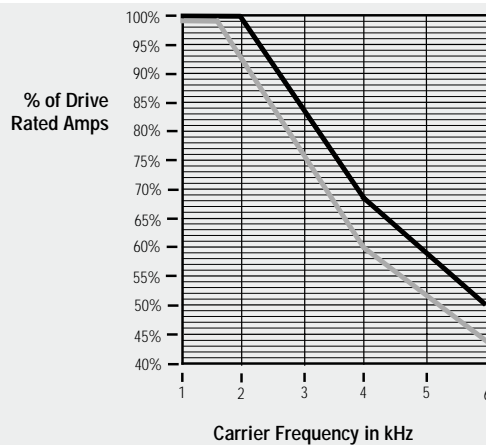

# 1336 IMPACT AC Drive Pre-Installation

## Derating Guidelines

— Standard Rating for Enclosed Drive in 40°C Ambient & Open Drive in 50°C Ambient.
 — Derating Factor for Enclosed Drive in Ambient between 41°C & 50°C.

**Figure 31**  
1336E-CP350

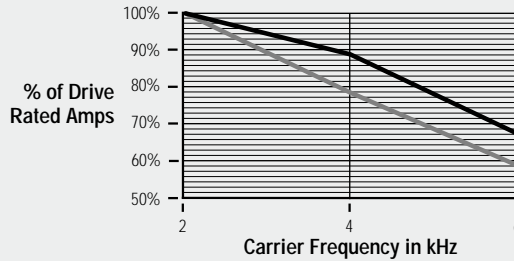

**Figure 32**  
1336E-C400

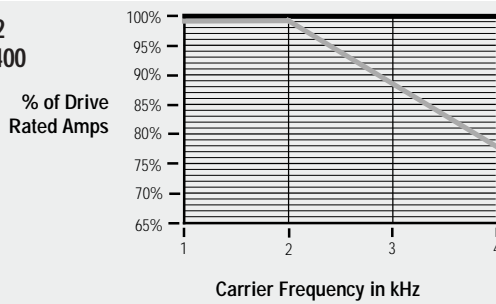

**Figure 33**  
1336E-CP400

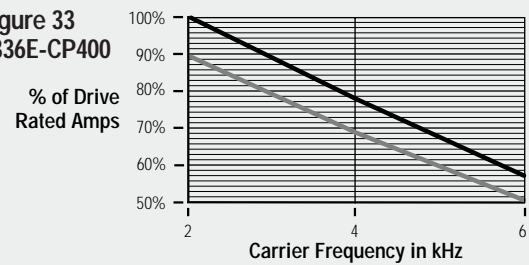

**Figure 34**  
1336E-C500

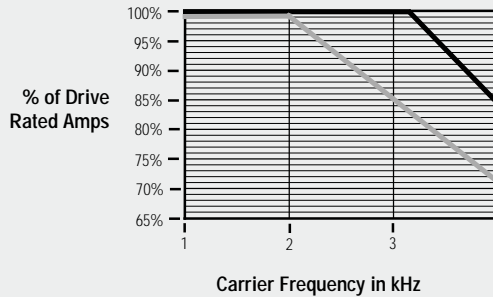

**Figure 35**  
1336E-C600

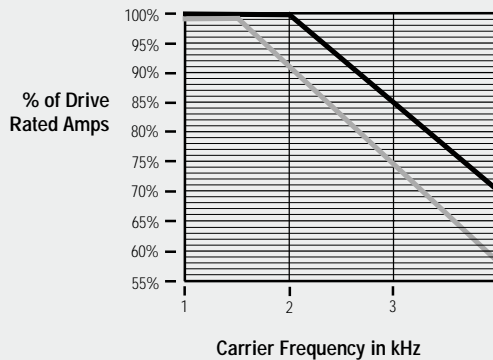

**Figure 36**  
1336E-C650

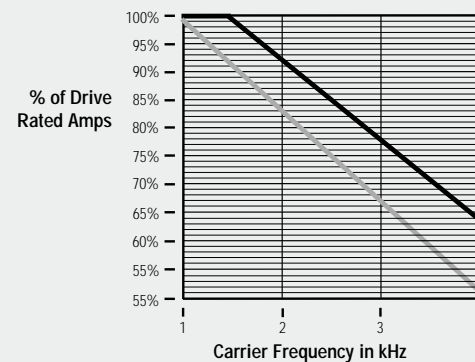

## Derating Guidelines

Standard Rating for Enclosed Drive in 40°C Ambient & Open Drive in 50°C Ambient.
  Derating Factor for Enclosed Drive in Ambient between 41°C & 50°C.

**Figure 37**  
1336E-B700C and B800C

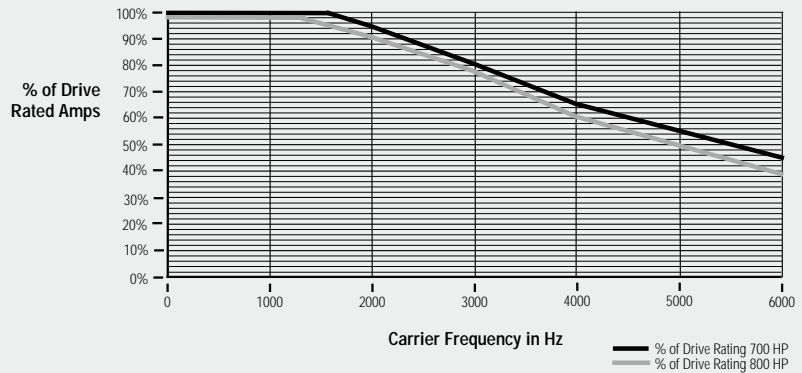

**Figure 38**  
1336E-C700C and C800C

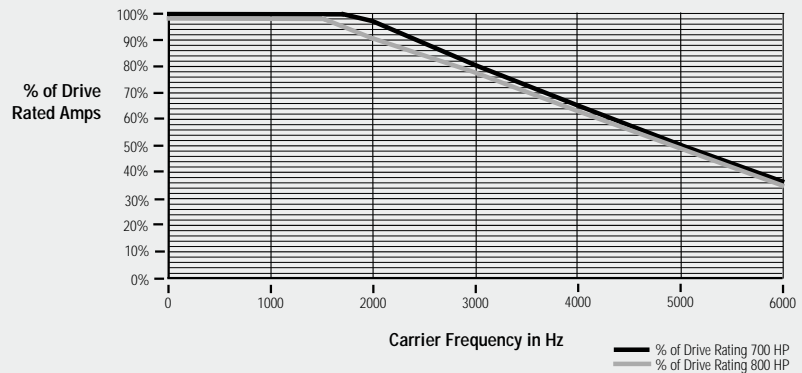
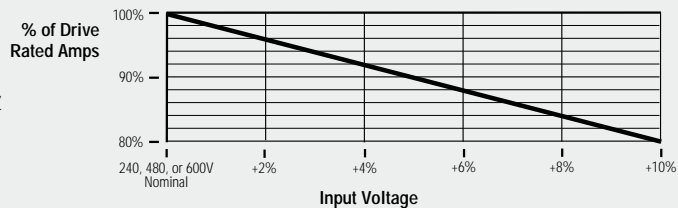

**Figure 39**  
All Drive Ratings



**Figure 40**  
Required Only for the following drives:

1336E-A/B/C-025 – 18.5 kW (25 HP) at 8 kHz  
 1336E-A/B/C – 22 kW (30HP) at 6-8 kHz  
 1336E-A/B/C – 45 kW (60 HP) at 6 kHz

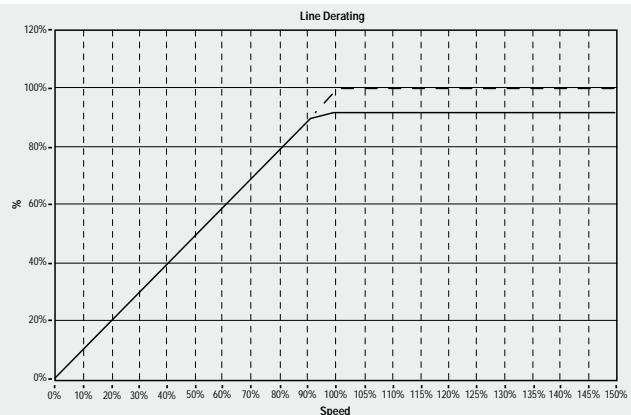

**Figure 41**  
Drive Ratings

Definitions:  
 Calculated HP – Available motor HP output based on full voltage/current

Actual HP – Measured HP based on DPI typical drive losses

Actual Motor HP  
 Calculated Motor HP



## 1336 IMPACT AC Drive Selection Guide

Notes

Features



Catalog Number Explanation

|              |                               |                                  |                                                        |                                                 |                                               |                                                  |
|--------------|-------------------------------|----------------------------------|--------------------------------------------------------|-------------------------------------------------|-----------------------------------------------|--------------------------------------------------|
| <b>1336E</b> | <b>B015</b>                   | <b>AA</b>                        | <b>EN</b>                                              | <b>L6</b>                                       | <b>HA1</b>                                    | <b>GM1</b>                                       |
| BULLETIN NO. | RATING<br>(MUST BE SPECIFIED) | ENCLOSURE<br>(MUST BE SPECIFIED) | LANGUAGE<br>MODULE<br>(MUST BE SPECIFIED) <sup>1</sup> | CONTROL<br>INTERFACE<br>(OPTIONAL) <sup>2</sup> | HUMAN<br>INTERFACE<br>(OPTIONAL) <sup>2</sup> | COMMUNICATION<br>CARD<br>(OPTIONAL) <sup>2</sup> |

<sup>1</sup> A Language Module must be specified with each drive.

<sup>2</sup> At least one of either a Control Interface, Human Interface or Communication Card Option will be required to make the drive functional. The chosen option(s) may be ordered factory installed or as add-on kits.

# 1336 IMPACT AC Drive Selection Guide

## Drive Codes and Enclosures

### 200-240V

| Frame Designation <sup>1</sup> | Drive Rating <sup>2</sup> |            |          | Open IP00<br>No Enclosure | NEMA Type 1 IP20<br>General Purpose <sup>3</sup> | NEMA Type 4 IP65<br>Resist Water, Dust | NEMA Type 12 IP54<br>Industrial Use |
|--------------------------------|---------------------------|------------|----------|---------------------------|--------------------------------------------------|----------------------------------------|-------------------------------------|
|                                | Output Amps               | Nominal HP | Rated kW |                           |                                                  |                                        |                                     |
| A1                             | 2.3                       | 1/2        | 0.37     | 1336E-AQF05-AN            | 1336E-AQF05-AA/AE                                | 1336E-AQF05-AF                         | 1336E-AQF05-AJ                      |
|                                | 3.0                       | 3/4        | 0.56     | 1336E-AQF07-AN            | 1336E-AQF07-AA/AE                                | 1336E-AQF07-AF                         | 1336E-AQF07-AJ                      |
|                                | 4.5                       | 1          | 0.75     | 1336E-AQF10-AN            | 1336E-AQF10-AA/AE                                | 1336E-AQF10-AF                         | 1336E-AQF10-AJ                      |
| A2                             | 6.0                       | 1-1/2      | 1.2      | 1336E-AQF15-AN            | 1336E-AQF15-AA/AE                                | 1336E-AQF15-AF                         | 1336E-AQF15-AJ                      |
|                                | 8.0                       | 2          | 1.5      | 1336E-AQF20-AN            | 1336E-AQF20-AA/AE                                | 1336E-AQF20-AF                         | 1336E-AQF20-AJ                      |
| A3                             | 12.0                      | 3          | 2.2      | 1336E-AQF30-AN            | 1336E-AQF30-AA/AE                                | 1336E-AQF30-AF                         | 1336E-AQF30-AJ                      |
|                                | 18.0                      | 5          | 3.7      | 1336E-AQF50-AN            | 1336E-AQF50-AA/AE                                | 1336E-AQF50-AF                         | 1336E-AQF50-AJ                      |
| B1                             | 27.2                      | 7.5        | 5.5      | 1336E-A007-AN             | 1336E-A007-AA/AE                                 | 1336E-A007-AF                          | 1336E-A007-AJ                       |
| B2                             | 33.7                      | 10         | 7.5      | 1336E-A010-AN             | 1336E-A010-AA/AE                                 | 1336E-A010-AF                          | 1336E-A010-AJ                       |
|                                | 48.2                      | 15         | 11       | 1336E-A015-AN             | 1336E-A015-AA/AE                                 | 1336E-A015-AF                          | 1336E-A015-AJ                       |
| C                              | 64.5                      | 20         | 15       | 1336E-A020-AN             | 1336E-A020-AA/AE                                 | 1336E-A020-AF                          | 1336E-A020-AJ                       |
|                                | 78.2                      | 25         | 18.5     | 1336E-A025-AN             | 1336E-A025-AA/AE                                 | 1336E-A025-AF                          | 1336E-A025-AJ                       |
|                                | 80.0                      | 30         | 22       | 1336E-A030-AN             | 1336E-A030-AA/AE                                 | 1336E-A030-AF                          | 1336E-A030-AJ                       |
| D                              | 120.3                     | 40         | 30       | 1336E-A040-AN             | 1336E-A040-AA/AE                                 | 4                                      | 1336E-A040C-AJ                      |
|                                | 149.2                     | 50         | 37       | 1336E-A050-AN             | 1336E-A050-AA/AE                                 | 4                                      | 1336E-A050C-AJ                      |
|                                | 180.4                     | 60         | 45       | 1336E-A060-AN             | 1336E-A060 AA/AE                                 | 4                                      | 1336E-A060C-AJ                      |
| E                              | 240.0                     | 75         | 56       | 1336E-A075-AN             | 1336E-A075-AA/AE                                 | 4                                      | 1336E-A075C-AJ                      |
|                                | 291.4                     | 100        | 75       | 1336E-A100-AN             | 1336E-A100-AA/AE                                 | 4                                      | 1336E-A100C-AJ                      |
|                                | 327.4                     | 125        | 93       | 1336E-A125-AN             | 1336E-A125-AA/AE                                 | 4                                      | 1336E-A125C-AJ                      |

### 380-460V

| Frame Designation <sup>1</sup> | Drive Rating <sup>2</sup> |            |          | Open IP00<br>No Enclosure   | NEMA Type 1 IP20<br>General Purpose | NEMA Type 1 IP20<br>CE Conformance | NEMA Type 4 IP65<br>Resist Water, Dust | NEMA Type 12 IP54<br>Industrial Use |
|--------------------------------|---------------------------|------------|----------|-----------------------------|-------------------------------------|------------------------------------|----------------------------------------|-------------------------------------|
|                                | Output Amps               | Nominal HP | Rated kW |                             |                                     |                                    |                                        |                                     |
| A1                             | 1.2                       | 1/2        | 0.37     | 1336E-BRF05-AN              | 1336E-BRF05-AA                      | 1336E-BRF05-AE                     | 1336E-BRF05-AF                         | 1336E-BRF05-AJ                      |
|                                | 1.7                       | 3/4        | 0.56     | 1336E-BRF07-AN              | 1336E-BRF07-AA                      | 1336E-BRF07-AE                     | 1336E-BRF07-AF                         | 1336E-BRF07-AJ                      |
|                                | 2.3                       | 1          | 0.75     | 1336E-BRF10-AN              | 1336E-BRF10-AA                      | 1336E-BRF10-AE                     | 1336E-BRF10-AF                         | 1336E-BRF10-AJ                      |
|                                | 3.0                       | 1-1/2      | 1.2      | 1336E-BRF15-AN              | 1336E-BRF15-AA                      | 1336E-BRF15-AE                     | 1336E-BRF15-AF                         | 1336E-BRF15-AJ                      |
| A2                             | 4.0                       | 2          | 1.5      | 1336E-BRF20-AN              | 1336E-BRF20-AA                      | 1336E-BRF20-AE                     | 1336E-BRF20-AF                         | 1336E-BRF20-AJ                      |
|                                | 6.0                       | 3          | 2.2      | 1336E-BRF30-AN              | 1336E-BRF30-AA                      | 1336E-BRF30-AE                     | 1336E-BRF30-AF                         | 1336E-BRF30-AJ                      |
| A3                             | 9.0                       | 5          | 3.7      | 1336E-BRF50-AN              | 1336E-BRF50-AA                      | 1336E-BRF50-AE                     | 1336E-BRF50-AF                         | 1336E-BRF50-AJ                      |
| A4                             | 13.9                      | 7.5        | 5.5      | 1336E-BRF75-AN              | 1336E-BRF75-AA                      | 1336E-BRF75-AE                     | 1336E-BRF75-AF                         | 1336E-BRF75-AJ                      |
|                                | 24                        | 10         | 7.5      | 1336E-BRF100-AN             | 1336E-BRF100-AA                     | 1336E-BRF100-AE                    | 1336E-BRF100-AF                        | 1336E-BRF100-AJ                     |
| B1                             | 27.2                      | 15         | 11       | 1336E-B015-AN               | 1336E-B015-AA                       | 1336E-B015-AE                      | 1336E-B015-AF                          | 1336E-B015-AJ                       |
| B2                             | 33.7                      | 20         | 15       | 1336E-B020-AN               | 1336E-B020-AA                       | 1336E-B020-AE                      | 1336E-B020-AF                          | 1336E-B020-AJ                       |
|                                | 41.8                      | 25         | 18.5     | 1336E-B025-AN               | 1336E-B025-AA                       | 1336E-B025-AE                      | 1336E-B025-AF                          | 1336E-B025-AJ                       |
|                                | 48.2                      | 30         | 22       | 1336E-B030-AN               | 1336E-B030-AA                       | 1336E-B030-AE                      | 1336E-B030-AF                          | 1336E-B030-AJ                       |
| C                              | 58.7                      | 40         | 30       | 1336E-BX040-AN              | 1336E-BX040-AA                      | 1336E-BX040-AE                     | 1336E-BX040-AF                         | 1336E-BX040-AJ                      |
|                                | 64.5                      | 40         | 30       | 1336E-B040-AN               | 1336E-B040-AA                       | 1336E-B040-AE                      | 1336E-B040-AF                          | 1336E-B040-AJ                       |
|                                | 78.2                      | 50         | 37       | 1336E-B050-AN               | 1336E-B050-AA                       | 1336E-B050-AE                      | 1336E-B050-AF                          | 1336E-B050-AJ                       |
|                                | 78.2                      | 60         | 45       | 1336E-BX060-AN <sup>5</sup> | 1336E-BX060-AA                      | 1336E-BX060-AE                     | 1336E-BX060-AF <sup>5</sup>            | 1336E-BX060-AJ <sup>5</sup>         |
| D                              | 96.9                      | 60         | 45       | 1336E-B060-AN               | 1336E-B060-AA                       | 1336E-B060-AE                      | 4                                      | 1336E-B060C-AJ                      |
|                                | 120.3                     | 75         | 56       | 1336E-B075-AN               | 1336E-B075-AA                       | 1336E-B075-AE                      | 4                                      | 1336E-B075C-AJ                      |
|                                | 149.2                     | 100        | 75       | 1336E-B100-AN               | 1336E-B100-AA                       | 1336E-B100-AE                      | 4                                      | 1336E-B100C-AJ                      |
|                                | 180.4                     | 125        | 93       | 1336E-B125-AN               | 1336E-B125-AA                       | 1336E-B125-AE                      | 4                                      | 1336E-B125C-AJ                      |
|                                | 180.4                     | 150        | 112      | 1336E-BX150-AN              | 1336E-BX150-AA                      | 1336E-BX150-AE                     | 4                                      | 1336E-BX150C-AJ                     |

<sup>1</sup> Refer to **Pages 15-22** for frame dimensions.

<sup>2</sup> Drive rating is based on nominal voltage and carrier frequency at altitudes of 1000 meters or less. Refer to Derating Guidelines on **Pages 43 to 51** for derating information.

<sup>3</sup> Conformance to CE also requires an EMC Filter and installation per the 1336 IMPACT User Manual, publication 1336 IMPACT-5.0.

<sup>4</sup> Not available in this rating.

<sup>5</sup> 480 volts only.

# 1336 IMPACT AC Drive Selection Guide

## Drive Codes and Enclosures

| 380-460V                       |                           |            |                 |                 |                  |                             |                    |                   |
|--------------------------------|---------------------------|------------|-----------------|-----------------|------------------|-----------------------------|--------------------|-------------------|
| Frame Designation <sup>1</sup> | Drive Rating <sup>2</sup> |            |                 | Open IP00       | NEMA Type 1 IP20 | NEMA Type 1 IP20            | NEMA Type 4 IP65   | NEMA Type 12 IP54 |
|                                | Output Amps               | Nominal HP | Rated kW        | No Enclosure    | General Purpose  | CE Conformance <sup>3</sup> | Resist Water, Dust | Industrial Use    |
| <b>E</b>                       | 240.0                     | 150        | 112             | 1336E-B150-AN   | 1336E-B150-AA    | 1336E-B150-AE               | 4                  | 1336E-B150C-AJ    |
|                                | 291.4                     | 200        | 149             | 1336E-B200-AN   | 1336E-B200-AA    | 1336E-B200-AE               | 4                  | 1336E-B200C-AJ    |
|                                | 327.4                     | 250        | 187             | 1336E-B250-AN   | 1336E-B250-AA    | 1336E-B250-AE               | 4                  | 1336E-B250C-AJ    |
| <b>F<sup>5</sup></b>           | 406.4                     | 300        | 224             | 1336E-BP300-AN  | 1336E-BP300-AA   | –                           | 4                  | 4                 |
|                                |                           |            |                 | 1336E-BPR300-AN | –                | 1336E-BPR300A-AE            |                    |                   |
|                                | 459.2                     | 350        | 261             | 1336E-BP350-AN  | 1336E-BP350-AA   | –                           | 4                  | 4                 |
|                                |                           |            |                 | 1336E-BPR350-AN | –                | 1336E-BPR350-A-AE           |                    |                   |
|                                | 481.0                     | 400        | 298             | 1336E-BP400-AN  | 1336E-BP400-AA   | –                           | 4                  | 4                 |
|                                |                           |            |                 | 1336E-BPR400-AN | –                | 1336E-BPR400A-AE            |                    |                   |
|                                | 450                       | 336        | 1336E-BP450-AN  | 1336E-BP450-AA  | –                | 4                           | 4                  |                   |
|                                |                           |            | 1336E-BPR450-AN | –               | 1336E-BPR450A-AE |                             |                    |                   |
| <b>G</b>                       | 406.4                     | 300        | 224             | 1336E-B300-AN   | 1336E-B300-AA    | 1336E-B300-AE               | 4                  | 1336E-B300C-AJ    |
|                                | 459.2                     | 350        | 261             | 1336E-B350-AN   | 1336E-B350-AA    | 1336E-B350-AE               | 4                  | 1336E-B350C-AJ    |
|                                | 505.1                     | 400        | 298             | 1336E-B400-AN   | 1336E-B400-AA    | 1336E-B400-AE               | 4                  | 1336E-B400C-AJ    |
|                                | 570.2                     | 450        | 336             | 1336E-B450-AN   | 1336E-B450-AA    | 1336E-B450-AE               | 4                  | 4                 |
|                                | 599.2                     | 500        | 373             | 1336E-B500-AN   | 1336E-B500-AA    | 1336E-B500-AE               | 4                  | 4                 |
|                                | 673.4                     | 600        | 448             | 1336E-B600-AN   | 1336E-B600-AA    | 1336E-B600-AE               | 4                  | 4                 |
| <b>H1</b><br>(6 pulse)         | 850.0                     | 700        | 522             | 4               | 1336E-B700C-AA   | 4                           | 4                  | 4                 |
|                                | 983.0                     | 800        | 597             | 4               | 1336E-B800C-AA   | 4                           | 4                  | 4                 |

| 500-600V                       |                           |            |               |                 |                  |                    |                   |  |
|--------------------------------|---------------------------|------------|---------------|-----------------|------------------|--------------------|-------------------|--|
| Frame Designation <sup>1</sup> | Drive Rating <sup>2</sup> |            |               | Open IP00       | NEMA Type 1 IP20 | NEMA Type 4 IP65   | NEMA Type 12 IP54 |  |
|                                | Output Amps               | Nominal HP | Rated kW      | No Enclosure    | General Purpose  | Resist Water, Dust | Industrial Use    |  |
| <b>A4</b>                      | 2.5                       | 1          | 0.75          | 1336E-CWF10-AN  | 1336E-CWF10-AA   | 1336E-CWF10-AF     | 1336E-CWF10-AJ    |  |
|                                | 4.2                       | 2          | 1.5           | 1336E-CWF20-AN  | 1336E-CWF20-AA   | 1336E-CWF20-AF     | 1336E-CWF20-AJ    |  |
|                                | 6.0                       | 3          | 2.2           | 1336E-CWF30-AN  | 1336E-CWF30-AA   | 1336E-CWF30-AF     | 1336E-CWF30-AJ    |  |
|                                | 7.9                       | 5          | 3.7           | 1336E-CWF50-AN  | 1336E-CWF50-AA   | 1336E-CWF50-AF     | 1336E-CWF50-AJ    |  |
|                                | 9.9                       | 7.5        | 5.5           | 1336E-CWF75-AN  | 1336E-CWF75-AA   | 1336E-CWF75-AF     | 1336E-CWF75-AJ    |  |
|                                | 12.0                      | 10         | 7.5           | 1336E-CWF100-AN | 1336E-CWF100-AA  | 1336E-CWF100-AF    | 1336E-CWF100-AJ   |  |
| <b>B</b>                       | 18.9                      | 15         | 11            | 1336E-C015-AN   | 1336E-C015-AA    | 1336E-C015-AF      | 1336E-C015-AJ     |  |
|                                | 23.6                      | 20         | 15            | 1336E-C020-AN   | 1336E-C020-AA    | 1336E-C020-AF      | 1336E-C020-AJ     |  |
| <b>C</b>                       | 30.0                      | 25         | 18.5          | 1336E-C025-AN   | 1336E-C025-AA    | 1336E-C025-AF      | 1336E-C025-AJ     |  |
|                                | 34.6                      | 30         | 22            | 1336E-C030-AN   | 1336E-C030-AA    | 1336E-C030-AF      | 1336E-C030-AJ     |  |
|                                | 45.1                      | 40         | 30            | 1336E-C040-AN   | 1336E-C040-AA    | 1336E-C040-AF      | 1336E-C040-AJ     |  |
|                                | 57.2                      | 50         | 37            | 1336E-C050-AN   | 1336E-C050-AA    | 1336E-C050-AF      | 1336E-C050-AJ     |  |
|                                | 61.6                      | 60         | 45            | 1336E-C060-AN   | 1336E-C060-AA    | 1336E-C060-AF      | 1336E-C060-AJ     |  |
| <b>D</b>                       | 85.8                      | 75         | 56            | 1336E-C075-AN   | 1336E-C075-AA    | 4                  | 1336E-C075C-AJ    |  |
|                                | 109.1                     | 100        | 75            | 1336E-C100-AN   | 1336E-C100-AA    | 4                  | 1336E-C100C-AJ    |  |
|                                | 138.6                     | 125        | 93            | 1336E-C125-AN   | 1336E-C125-AA    | 4                  | 1336E-C125C-AJ    |  |
| <b>E</b>                       | 159.7                     | 150        | 112           | 1336E-C150-AN   | 1336E-C150-AA    | 4                  | 1336E-C150C-AJ    |  |
|                                | 252.5                     | 200        | 149           | 1336E-C200-AN   | 1336E-C200-AA    | 4                  | 1336E-C200C-AJ    |  |
|                                | 283.6                     | 250        | 187           | 1336E-C250-AN   | 1336E-C250-AA    | 4                  | 1336E-C250C-AJ    |  |
| <b>F</b>                       | 350.0                     | 350        | 261           | 1336E-CP350-AN  | 1336E-CP350-AA   | 4                  | 4                 |  |
|                                |                           |            |               | 1336E-CPR350-AN | –                | 4                  | 4                 |  |
|                                | 400.0                     | 400        | 298           | 1336E-CP400-AN  | 1336E-CP400-AA   | 4                  | 4                 |  |
|                                |                           |            |               | 1336E-CPR400-AN | –                | 4                  | 4                 |  |
| <b>G</b>                       | 298.0                     | 300        | 224           | 1336E-C300-AN   | 1336E-C300-AA    | 4                  | 1336E-C300C-AJ    |  |
|                                | 353.6                     | 350        | 261           | 1336E-C350-AN   | 1336E-C350-AA    | 4                  | 1336E-C350C-AJ    |  |
|                                | 406.4                     | 400        | 298           | 1336E-C400-AN   | 1336E-C400-AA    | 4                  | 1336E-C400C-AJ    |  |
|                                | 459.2                     | 450        | 336           | 1336E-C450-AN   | 1336E-C450-AA    | 4                  | 4                 |  |
|                                | 505.1                     | 500        | 373           | 1336E-C500-AN   | 1336E-C500-AA    | 4                  | 4                 |  |
|                                | 599.2                     | 600        | 448           | 1336E-C600-AN   | 1336E-C600-AA    | 4                  | 4                 |  |
| 673.4                          | 650                       | 485        | 1336E-C650-AN | 1336E-C650-AA   | 4                | 4                  |                   |  |
| <b>H1</b><br>(6 pulse)         | 770.0                     | 700        | 522           | 4               | 1336E-C700C-AA   | 4                  | 4                 |  |
|                                | 800.0                     | 800        | 597           | 4               | 1336E-C800C-AA   | 4                  | 4                 |  |

<sup>1</sup> Refer to **Pages 15-22** for frame dimensions.

<sup>2</sup> Drive rating is based on nominal voltage and carrier frequency at altitudes of 1000 meters or less. Refer to Derating Guidelines on **Pages 43 to 51** for derating information.

<sup>3</sup> Conformance to CE also requires an EMC Filter and installation per the 1336 IMPACT User Manual, publication 1336 IMPACT-5.0.

<sup>4</sup> Not available in this rating.

<sup>5</sup> Option -CM (common mode choke) or Option -NCM (no common mode choke) must be specified with each F frame drive.

# 1336 IMPACT AC Drive Selection Guide

## Control Interface Kits (Factory Installed)

| Description                             | Used With . . .  | Option Code (Installed) |
|-----------------------------------------|------------------|-------------------------|
| Control Interface                       | ALL 1336E Drives |                         |
| Contact Closure                         |                  | - L4                    |
| +24V AC/DC                              |                  | - L5                    |
| 115V AC                                 |                  | - L6                    |
| Control Interface with Encoder Feedback | All 1336E Drives |                         |
| Contact Closure                         |                  | - L7E                   |
| +24V AC/DC                              |                  | - L8E                   |
| 115V AC                                 |                  | - L9E                   |

## Human Interface Module Kits (Factory Installed)

| Description                            | Used With . . .                           | Option Code (Installed) |
|----------------------------------------|-------------------------------------------|-------------------------|
| Human Interface Module, NEMA Type 1    | IP00 (Open) and IP20 (NEMA Type 1) Drives |                         |
| Blank - No Functionality               |                                           | -HAB                    |
| Programmer Only                        |                                           | -HAP                    |
| Programmer/Controller with Analog Pot  |                                           | -HA1                    |
| Programmer/Controller with Digital Pot |                                           | -HA2                    |
| Human Interface Module, NEMA Type 12   | IP66 or IP54 (NEMA Type 12) Drives        |                         |
| Programmer Only                        |                                           | -HJP <sup>1</sup>       |
| Programmer/Controller with Digital Pot |                                           | -HJ2 <sup>1</sup>       |

## Communications Options (Factory Installed)

| Description                         | Used With . . .            | Option Code       |
|-------------------------------------|----------------------------|-------------------|
| Single Point RIO                    | Frame B, C, D, E, F, G & H | -GM1 <sup>2</sup> |
| RS232/422/485, DF1 & DH485 Protocol |                            | -GM2 <sup>2</sup> |
| DeviceNet                           |                            | -GM5 <sup>2</sup> |
| Enhanced DeviceNet                  |                            | -GM6 <sup>2</sup> |

## Common Mode Choke for F Frame Drives Only (Factory Installed — Select One)

| Description                            | Used With . . .    | Option Code |
|----------------------------------------|--------------------|-------------|
| No Common Mode Choke                   | All F Frame Drives | -NCM        |
| Internal Common Mode Choke – Installed |                    | -CM         |
| Internal Common Mode Choke – Installed | All G Frame Drives | -CM         |

## Control Interface Kits (For Customer Installation)

| Description                             | Used With . . .  | Option Code (Installed) |
|-----------------------------------------|------------------|-------------------------|
| Control Interface                       | All 1336E Drives |                         |
| Contact Closure                         |                  | 1336-L4                 |
| 24V AC/DC                               |                  | 1336-L5                 |
| 115V AC                                 |                  | 1336-L6                 |
| Control Interface with Encoder Feedback | All 1336E Drives |                         |
| Contact Closure                         |                  | 1336-L7E                |
| 24V AC/DC                               |                  | 1336-L8E                |
| 115V AC                                 |                  | 1336-L9E                |

## Gasket and Enclosure Kits (For Customer Installation)

| Description <sup>3</sup>                                                                                  | Used with Frame Designation <sup>3</sup> | Catalog Number (Loose Kit) |             |                        |
|-----------------------------------------------------------------------------------------------------------|------------------------------------------|----------------------------|-------------|------------------------|
|                                                                                                           |                                          | 200-240V                   | 380-480V    | 500-600V               |
| Gasket Kits<br>For mounting 1336E Drives<br>in User Supplied IP54 or 65<br>(NEMA Type 12 or 4) Enclosures | A1, A2, A3                               | 1336-RF3                   | 1336-RF3    | –                      |
|                                                                                                           | A4                                       | –                          | 1336-RF2    | 1336-RF2               |
|                                                                                                           | B                                        | 1336-RF4                   | 1336-RF4    | 1336-RF4               |
|                                                                                                           | C                                        | 1336-RF5                   | 1336-RF5    | 1336-RF5               |
| Gasket Kits<br>For mounting 1336E Drives<br>in User Supplied IP54<br>(NEMA Type 12) Enclosures            | D                                        | 1336-RF6                   | 1336-RF6    | 1336-RF6               |
|                                                                                                           | E                                        | 1336-RF7                   | 1336-RF7    | 1336-RF7               |
| Enclosure Kits<br>IP20 (NEMA Type 1)                                                                      | A1, A2, A3                               | 1336E-AA3                  | 1336E-AA3   | –                      |
|                                                                                                           | A4                                       | –                          | 1336E-AA2   | 1336E-AA2              |
|                                                                                                           | B                                        | 1336E-AA4                  | 1336E-AA4   | 1336E-AA4              |
|                                                                                                           | C                                        | 1336E-AA5                  | 1336E-AA5   | 1336E-AA5              |
|                                                                                                           | D                                        | 1336E-AA6                  | 1336E-AA6   | 1336E-AA6              |
|                                                                                                           | E                                        | 1336E-AA7                  | 1336E-AA7   | 1336E-AA7              |
| Enclosure Kits<br>IP20 (NEMA Type 1)<br>for CE Conformance                                                | A1, A2, A3                               | 1336E-AE3                  | 1336E-AE3   | –                      |
|                                                                                                           | A4                                       | 1336E-AE2                  | 1336E-AE2   | –                      |
|                                                                                                           | B                                        | 1336E-AE4                  | 1336E-AE4   | 1336E-AE4 <sup>5</sup> |
|                                                                                                           | C                                        | 1336E-AE5                  | 1336E-AE5   | 1336E-AE5 <sup>5</sup> |
|                                                                                                           | D                                        | 1336E-AE6                  | 1336E-AE6   | 1336E-AE6 <sup>5</sup> |
|                                                                                                           | E                                        | 1336E-AE7                  | 1336E-AE7   | 1336E-AE7 <sup>5</sup> |
| Enclosure Kits<br>IP54 (NEMA Type 12)                                                                     | A1, A2, A3                               | 1336E-AJA3                 | 1336E-AJA3  | –                      |
|                                                                                                           | A4                                       | –                          | 1336E-AJA4B | 1336E-AJA4C            |
|                                                                                                           | B1                                       | 1336E-AJB1A                | 1336E-AJB1B | 1336E-AJB1C            |
|                                                                                                           | B2                                       | 1336E-AJB2A                | 1336E-AJB2B | 1336E-AJB2C            |
|                                                                                                           | C                                        | 1336E-AJCA                 | 1336E-AJCB  | 1336E-AJCC             |
| Enclosure Kits <sup>4</sup><br>IP65 (NEMA Type 4)                                                         | A1, A2, A3                               | 1336E-AFA3                 | 1336E-AFA3  | –                      |
|                                                                                                           | A4                                       | –                          | 1336E-AFA4B | 1336E-AFA4C            |
|                                                                                                           | B1                                       | 1336E-AFB1A                | 1336E-AFB1B | 1336E-AFB1C            |
|                                                                                                           | B2                                       | 1336E-AFB2A                | 1336E-AFB2B | 1336E-AFB2C            |
|                                                                                                           | C                                        | 1336E-AFCA                 | 1336E-AFCB  | 1336E-AFCC             |

<sup>1</sup> This option may be used on an IP65 or IP66 rated enclosure to meet watertight indoor applications.

<sup>2</sup> Requires a Communication Option Cable (1202-C03/C10/C30/C90) to be functional. These units are not acceptable for NEMA Type 4 door mounting or UL Type 4x outdoor duty.

<sup>3</sup> Refer to Page 14 for frame designations.

<sup>4</sup> Use of a door mounted Human Interface Module on these enclosures will void the NEMA Type 4 rating.

# 1336 IMPACT AC Drive Selection Guide

## Language Group (Factory Installed)

| Description | Used With . . .  | Option Code |
|-------------|------------------|-------------|
| English     | All 1336E Drives | -EN         |
| French      |                  | -FR         |
| German      |                  | -DE         |
| Italian     |                  | -IT         |
| Portuguese  |                  | -PT         |
| Spanish     |                  | -ES         |

## Language Group (User Installed)

| Description        | Used With . . .    | Option Code |
|--------------------|--------------------|-------------|
| English/English    | All 1336E Drives   | 1336E-EN31  |
| English/French     | with 3.xx firmware | 1336E-FR31  |
| English/German     |                    | 1336E-DE31  |
| English/Italian    |                    | 1336E-IT31  |
| English/Portuguese |                    | 1336E-PT31  |
| English/Spanish    |                    | 1336E-ES31  |

## Dynamic Brake Kits (For Customer Installation)

| Description <sup>1</sup> | Used With . . .        | Catalog Number Complete Brake | Catalog Number Brake Chopper |
|--------------------------|------------------------|-------------------------------|------------------------------|
| for 200-240V AC Drives   | 0.37-3.7 kW (0.5-5 HP) | 1336-MOD-KA005                | 1336-WA018                   |
|                          | 5.5-7.5 kW (7.5-10 HP) | 1336-MOD-KA010                | 1336-WA018                   |
|                          | 11-22 kW (15-30 HP)    | NA                            | 1336-WA070                   |
|                          | 30-56 kW (40-75 HP)    | NA                            | 1336-WA115                   |
| for 380-480V AC Drives   | 0.37-3.7 kW (0.5-5 HP) | 1336-MOD-KB005                | 1336-WB009                   |
|                          | 5.5-7.5 kW (7.5-10 HP) | 1336-MOD-KB010                | 1336-WB009                   |
|                          | 11-37 kW (15-50 HP)    | 1336-MOD-KB050                | 1336-WB035                   |
|                          | 45-149 kW (60-200 HP)  | NA                            | 1336-WB110                   |
| for 500-600V AC Drives   | 0.37-3.7 kW (0.5-5 HP) | 1336-MOD-KC005                | 1336-WC009                   |
|                          | 5.5-7.5 kW (7.5-10 HP) | 1336-MOD-KC010                | 1336-WC009                   |
|                          | 11-30 kW (15-40 HP)    | 1336-MOD-KC050                | 1336-WC035                   |
|                          | 37-149 kW (50-200 HP)  | NA                            | 1336-WC085                   |

## Terminator Kits (For Customer Installation)

| Description <sup>1</sup>                         | Used With . . .                             | Catalog Number         |
|--------------------------------------------------|---------------------------------------------|------------------------|
| IP65 (NEMA Type 4x)<br>Connection Cable Included | 0.75-3.7 KW (1-5 HP),<br>460V Drives        | 1204-TFA1 <sup>4</sup> |
|                                                  | 2.2-448 KW (3-600 HP),<br>460 & 575V Drives | 1204-TFB2              |

## Communication Option Kits (For Customer Installation)

| Description                                                                                                                | Used With . . .                                 | Catalog Number (Loose Kit) |
|----------------------------------------------------------------------------------------------------------------------------|-------------------------------------------------|----------------------------|
| Remote Mounted With Integral 115V AC Power Supply<br>Single Point RIO<br>RS232/422/485, DF1 and DH485 Protocol             | All 1336E Drive Ratings                         | 1203-GD1 <sup>2</sup>      |
|                                                                                                                            |                                                 | 1203-GD2 <sup>2</sup>      |
| Remote Mounted, For Use With 24V DC Power Supply<br>Single Point RIO<br>RS232/422/485, DF1 and DH485 Protocol<br>DeviceNet | All 1336E Drive Ratings                         | 1203-GK1 <sup>2</sup>      |
|                                                                                                                            |                                                 | 1203-GK2 <sup>2</sup>      |
|                                                                                                                            |                                                 | 1203-GK5 <sup>2</sup>      |
| Communication Option Cable Kits                                                                                            | All Communications Options Listed Above         | 1202-C03                   |
|                                                                                                                            |                                                 | 1202-C10                   |
|                                                                                                                            |                                                 | 1202-C30                   |
|                                                                                                                            |                                                 | 1202-C90                   |
| SCANport Expander Module<br>One to Two<br>One to Four                                                                      | All Drive Ratings                               | 1203-SG2                   |
|                                                                                                                            |                                                 | 1203-SG4                   |
| Drive Mounted and Drive Powered<br>Single Point RIO<br>RS232/422/485, DF1 and DH485 Protocol<br>DeviceNet                  | 1336E Drives –<br>Frames B, C, D, E,<br>F and G | 1336-GM1                   |
|                                                                                                                            |                                                 | 1336-GM2                   |
|                                                                                                                            |                                                 | 1336-GM5                   |
| Flex I/O Terminal<br>Flex I/O Terminal Base<br>Flex I/O Module                                                             | All Drive Ratings                               | 1203-FB1 <sup>3</sup>      |
|                                                                                                                            | All Drive Ratings                               | 1203-FM1 <sup>2, 3</sup>   |
| SLC Communication Module                                                                                                   | All Drive Ratings                               | 1203-SM1                   |

<sup>1</sup> Multiple kits may be utilized together to obtain higher HP ratings. Refer to Publication 1336-5.64 or 1336-5.65 for guidance.

<sup>2</sup> Requires a Communication Option Cable (1202-C03/C10/C30/C90) to be functional.

<sup>3</sup> Each Flex I/O SCANport requires (1)1203-FB1 and (1)1203-FM1.

<sup>4</sup> Limited to motor cable lengths of 61 meters (200 feet).

# 1336 IMPACT AC Drive Selection Guide

## Human Interface Module Kits (For Customer Installation)

| Description                            | Used With<br>(Loose Kit)                                                          | Catalog Number        |
|----------------------------------------|-----------------------------------------------------------------------------------|-----------------------|
| NEMA Type 1 (Normal)                   | All Open Chassis and<br>NEMA Type 1 1336E Drives                                  |                       |
| Blank-No Functionality                 |                                                                                   | 1201-HAB              |
| Programmer Only                        |                                                                                   | 1201-HAP              |
| Programmer/Controller with Analog Pot  |                                                                                   | 1201-HA1              |
| Programmer/Controller with Digital Pot |                                                                                   | 1201-HA2              |
| NEMA Type 4                            | All NEMA Type 4 & 12 1336E Drives                                                 |                       |
| Programmer Only                        |                                                                                   | 1201-HFP <sup>1</sup> |
| Programmer/Controller with Digital Pot |                                                                                   | 1201-HF2 <sup>1</sup> |
| Door Mount Bezel Kit, NEMA Type 1      | Customer Supplied<br>NEMA Type 1 Enclosures and<br>Normal NEMA Type 1 HIM Modules | 1201-DMA              |
| Option Cable Kits                      | All Human Interface Modules Not<br>Mounted on the Drive Chassis                   |                       |
| (Connects to HIM Cradle Port)          |                                                                                   |                       |
| One-Third Meter Length                 |                                                                                   | 1202-H03              |
| One Meter Length                       |                                                                                   | 1202-H10              |
| Three Meter Length                     |                                                                                   | 1202-H30              |
| Nine Meter Length                      |                                                                                   | 1202-H90              |
| (Connects to Communication Port)       |                                                                                   |                       |
| One-Third Meter Length                 |                                                                                   | 1202-C03              |
| One Meter Length                       |                                                                                   | 1202-C10              |
| Three Meter Length                     |                                                                                   | 1202-C30              |
| Nine Meter Length                      |                                                                                   | 1202-C90              |

<sup>1</sup> Requires a Communication Option Cable (1202-C03/C10/C30/C90) to be functional.

# 1336 IMPACT AC Drive Selection Guide

## Lug Kits (For Customer Installation)

| Description        | Voltage          | Horsepower | Frame Designation | Catalog Number (Loose Kit) |
|--------------------|------------------|------------|-------------------|----------------------------|
| Lug Kit, Includes: |                  |            |                   |                            |
| (3) Input Lugs     | 240V AC/310 V DC | 40 HP      | D                 | 1336-LUG-AQ040             |
| (3) Output Lugs    |                  | 50 HP      | D                 | 1336-LUG-AQ050             |
| (2) DC Bus Lugs    |                  | 60 HP      | D                 | 1336-LUG-AQ060             |
| (2) TE Ground Lugs |                  | 75 HP      | E                 | 1336-LUG-AQ075             |
| (1) PE Ground Lug  |                  | 100 HP     | E                 | 1336-LUG-AQ100             |
| <hr/>              |                  |            |                   |                            |
| 480V AC/620V DC    |                  |            |                   |                            |
|                    |                  | 60 HP      | D                 | 1336-LUG-BR060             |
|                    |                  | 75 HP      | D                 | 1336-LUG-BR075             |
|                    |                  | 100 HP     | D                 | 1336-LUG-BR100             |
|                    |                  | 125 HP     | D                 | 1336-LUG-BR125             |
|                    |                  | X150 HP    | D                 | 1336-LUG-BRX150            |
|                    |                  | 150 HP     | D                 | 1336-LUG-BR150             |
|                    |                  | 200 HP     | E                 | 1336-LUG-BR200             |
|                    |                  | 250 HP     | E                 | 1336-LUG-BR250             |
| <hr/>              |                  |            |                   |                            |
| 600V AC/775V DC    |                  |            |                   |                            |
|                    |                  | 60 HP      | D                 | 1336-LUG-CW060             |
|                    |                  | 75 HP      | D                 | 1336-LUG-CW075             |
|                    |                  | 100 HP     | D                 | 1336-LUG-CW100             |
|                    |                  | 125 HP     | D                 | 1336-LUG-CW125             |
|                    |                  | 150 HP     | E                 | 1336-LUG-CW150             |
|                    |                  | 200 HP     | E                 | 1336-LUG-CW200             |
|                    |                  | 250 HP     | E                 | 1336-LUG-CW250             |

## Common Mode Choke Kits (For Customer Installation)

| Description <sup>1</sup>                | Used With . . .                                                                                                   | Catalog Number |
|-----------------------------------------|-------------------------------------------------------------------------------------------------------------------|----------------|
| Open Style, 1A                          | Communication and Signal Type Cables                                                                              | 1321-M001      |
| Open Style, 9A<br>(with Terminal Block) | All Drives Rated:<br>230V, 0.37-1.5 kW (0.5-2 HP)<br>480V, 0.37-3.7 kW (0.5-5 HP)                                 | 1321-M009      |
| Open Style, 48A                         | All Drives Rated:<br>230V, 2.2-11 kW (3-15 HP)<br>480V, 5.5-22 kW (7.5-30 HP)<br>600V, 0.75-30 kW (1-40 HP)       | 1321-M048      |
| Open Style, 180A                        | All Drives Rated:<br>230V, 15-45 kW (20-60 HP)<br>480V, 30-112 kW (40-X150 HP)<br>600V, 37-112 kW (50-150 HP)     | 1321-M180      |
| Open Style, 670A                        | All Drives Rated:<br>230V, 56-93 kW (75-125 HP)<br>480V, 112-448 kW (150-600 HP)<br>600V, 149-448 kW (200-600 HP) | 1321-M670      |

## Line Reactor Kits (For Customer Installation)

### LINE REACTORS and ISOLATION TRANSFORMERS (FOR REMOTE CUSTOMER INSTALLATION)

#### SPECIFICATIONS:

LINE REACTORS – Iron core, 3% impedance, 600V, Class H insulation, 115°C rise, copper wound, 50.60 Hz., terminal blocks (80A and below), copper box lugs (160A and above), UL, CSA.

#### ISOLATION TRANSFORMERS:

230V/230V or 460V/460V Delta primary/Wye secondary. Class H insulation, 150°C rise, aluminum wound, 60 Hz ±5% taps, (1) NC thermostat per coil, UL, CSA.

### Line reactors 200-230V AC Input

| Drive Ratings kW (HP) | Input or Output Line Reactor – 3% Impedance |                           |                          |                           | Input or Output Line Reactor – 5% Impedance |                |                    |  |
|-----------------------|---------------------------------------------|---------------------------|--------------------------|---------------------------|---------------------------------------------|----------------|--------------------|--|
|                       | IP00 (Open Style)                           |                           | IP11 (NEMA Type 1)       |                           | IP00 (Open Style)                           |                | IP11 (NEMA Type 1) |  |
|                       | Catalog Number                              | Catalog Number            | Catalog Number           | Catalog Number            | Catalog Number                              | Catalog Number | Catalog Number     |  |
| 0.37 (0.50)           | 1321-3R2-D                                  | 1321-3RA2-D               | 1321-3R2-A               | 1321-3RA2-A               |                                             |                |                    |  |
| 0.56 (0.75)           | 1321-3R4-A                                  | 1321-3RA4-A               | 1321-3R4-B               | 1321-3RA4-B               |                                             |                |                    |  |
| 0.75 (1)              | 1321-3R4-A                                  | 1321-3RA4-A               | 1321-3R4-B               | 1321-3RA4-B               |                                             |                |                    |  |
| 1.2 (1.5)             | 1321-3R8-A                                  | 1321-3RA8-A               | 1321-3R8-B               | 1321-3RA8-B               |                                             |                |                    |  |
| 1.5 (2)               | 1321-3R8-A                                  | 1321-3RA8-A               | 1321-3R8-B               | 1321-3RA8-B               |                                             |                |                    |  |
| 2.2 (3)               | 1321-3R12-A                                 | 1321-3RA12-A              | 1321-3R12-B              | 1321-3RA12-B              |                                             |                |                    |  |
| 3.7 (5)               | 1321-3R18-A                                 | 1321-3RA18-A              | 1321-3R18-B              | 1321-3RA18-B              |                                             |                |                    |  |
| 5.5 (7.5)             | 1321-3R25-A                                 | 1321-3RA25-A              | 1321-3R25-B              | 1321-3RA25-B              |                                             |                |                    |  |
| 7.5 (10)              | 1321-3R35-A                                 | 1321-3RA35-A              | 1321-3R35-B              | 1321-3RA35-B              |                                             |                |                    |  |
| 11 (15)               | 1321-3R45-A                                 | 1321-3RA45-A              | 1321-3R45-B              | 1321-3RA45-B              |                                             |                |                    |  |
| 15 (20) <sup>1</sup>  | 1321-3R55-A <sup>1</sup>                    | 1321-3RA55-A <sup>1</sup> | 1321-3R55-B <sup>1</sup> | 1321-3RA55-B <sup>1</sup> |                                             |                |                    |  |
| 15 (20)               | 1321-3R80-A                                 | 1321-3RA80-A              | 1321-3R80-B              | 1321-3RA80-B              |                                             |                |                    |  |
| 18.5 (25)             | 1321-3R80-A                                 | 1321-3RA80-A              | 1321-3R80-B              | 1321-3RA80-B              |                                             |                |                    |  |
| 22 (30)               | 1321-3R80-A                                 | 1321-3RA80-A              | 1321-3R80-B              | 1321-3RA80-B              |                                             |                |                    |  |
| 30 (40)               | 1321-3R130-A                                | 1321-3RA130-A             | 1321-3R130-B             | 1321-3RA130-B             |                                             |                |                    |  |
| 37 (50)               | 1321-3R160-A                                | 1321-3RA160-A             | 1321-3R160-B             | 1321-3RA160-B             |                                             |                |                    |  |
| 45 (60)               | 1321-3R200-A                                | 1321-3RA200-A             | 1321-3R200-B             | 1321-3RA200-B             |                                             |                |                    |  |
| 56 (75)               | 1321-3RB250-A                               | 1321-3RA250-A             | 1321-3RB250-B            | 1321-3RA250-B             |                                             |                |                    |  |
| 75 (100)              | 1321-3RB320-A                               | 1321-3RA320-A             | 1321-3RB320-B            | 1321-3RA320-B             |                                             |                |                    |  |
| 93 (125)              | 1321-3RB320-A                               | 1321-3RA320-A             | 1321-3RB320-B            | 1321-3RA320-B             |                                             |                |                    |  |

<sup>1</sup> Input Reactor Only.

# 1336 IMPACT AC Drive Selection Guide

## Line Reactor Kits (For Remote Customer Installation)

### LINE REACTORS and ISOLATION TRANSFORMERS (FOR REMOTE CUSTOMER INSTALLATION)

#### SPECIFICATIONS:

LINE REACTORS – Iron core, 3% impedance, 600V, Class H insulation, 115°C rise, copper wound, 50.60 Hz, terminal blocks (80A and below), copper box lugs (160A and above), UL, CSA.

#### ISOLATION TRANSFORMERS:

230V/230V or 460V/460V Delta primary/Wye secondary. Class H insulation, 150°C rise, aluminum wound, 60 Hz ±5% taps, (1) NC thermostat per coil, UL, CSA.

### LINE REACTORS 380-480V AC INPUT

| Drive Ratings kW (HP)  | Input or Output Line Reactor – 3% Impedance |                    | Input or Output Line Reactor – 5% Impedance |                    |
|------------------------|---------------------------------------------|--------------------|---------------------------------------------|--------------------|
|                        | IP00 (Open Style)                           | IP10 (NEMA Type 1) | IP00 (Open Style)                           | IP10 (NEMA Type 1) |
| 0.37 (0.50)            | 1321-3R2-B                                  | 1321-3RA2-B        | 1321-3R2-B                                  | 1321-3RA2-B        |
| 0.56 (0.75)            | 1321-3R2-B                                  | 1321-3RA2-B        | 1321-3R2-B                                  | 1321-3RA2-B        |
| 0.75 (1)               | 1321-3R2-A                                  | 1321-3RA2-A        | 1321-3R2-B                                  | 1321-3RA2-B        |
| 1.2 (1.5)              | 1321-3R4-B                                  | 1321-3RA4-B        | 1321-3R4-C                                  | 1321-3RA4-C        |
| 1.5 (2)                | 1321-3R4-B                                  | 1321-3RA4-B        | 1321-3R4-C                                  | 1321-3RA4-C        |
| 2.2 (3)                | 1321-3R8-B                                  | 1321-3RA8-B        | 1321-3R8-C                                  | 1321-3RA8-C        |
| 3.7 (5)                | 1321-3R8-B                                  | 1321-3RA8-B        | 1321-3R8-C                                  | 1321-3RA8-C        |
| 5.5 (7.5)              | 1321-3R12-B                                 | 1321-3RA12-B       | 1321-3R12-C                                 | 1321-3RA12-C       |
| 7.5 (10)               | 1321-3R18-B                                 | 1321-3RA18-B       | 1321-3R18-C                                 | 1321-3RA18-C       |
| 11 (15)                | 1321-3R25-B                                 | 1321-3RA25-B       | 1321-3R25-C                                 | 1321-3RA25-C       |
| 15 (20)                | 1321-3R35-B                                 | 1321-3RA35-B       | 1321-3R35-C                                 | 1321-3RA35-C       |
| 18.5 (25)              | 1321-3R35-B                                 | 1321-3RA35-B       | 1321-3R35-C                                 | 1321-3RA35-C       |
| 22 (30)                | 1321-3R45-B                                 | 1321-3RA45-B       | 1321-3R45-C                                 | 1321-3RA45-C       |
| 30 (40)                | 1321-3R55-B                                 | 1321-3RA55-B       | 1321-3R55-C                                 | 1321-3RA55-C       |
| 37 (50)                | 1321-3R80-B                                 | 1321-3RA80-B       | 1321-3R80-C                                 | 1321-3RA80-C       |
| 45 (60)                | 1321-3R80-B                                 | 1321-3RA80-B       | 1321-3R80-C                                 | 1321-3RA80-C       |
| 56 (75)                | 1321-3R100-B                                | 1321-3RA100-B      | 1321-3R100-C                                | 1321-3RA100-C      |
| 75 (100)               | 1321-3R130-B                                | 1321-3RA130-B      | 1321-3R130-C                                | 1321-3RA130-C      |
| 95 (125)               | 1321-3R160-B                                | 1321-3RA160-B      | 1321-3R160-C                                | 1321-3RA160-C      |
| 112 (150)              | 1321-3R200-B                                | 1321-3RA200-B      | 1321-3R200-C                                | 1321-3RA200-C      |
| 149 (200)              | 1321-3RB250-B                               | 1321-3RA250-B      | 1321-3RB250-C                               | 1321-3RA250-C      |
| 187 (250)              | 1321-3RB320-B                               | 1321-3RA320-B      | 1321-3RB320-C                               | 1321-3RA320-C      |
| 224 (300)              | 1321-3RB400-B                               | 1321-3RA400-B      | 1321-3RB400-C                               | 1321-3RA400-C      |
| 261 (350) <sup>1</sup> | 1321-3RB400-B                               | 1321-3RA400-B      | 1321-3RB400-C                               | 1321-3RA400-C      |
| 261 (350)              | 1321-3R500-B                                | 1321-3RA500-B      | 1321-3R500-C                                | 1321-3RA500-C      |
| 298 (400)              | 1321-3R500-B                                | 1321-3RA500-B      | 1321-3R500-C                                | 1321-3RA500-C      |
| 336 (450) <sup>1</sup> | 1321-3R500-B                                | 1321-3RA500-B      | 1321-3R500-C                                | 1321-3RA500-C      |
| 336 (450)              | 1321-3R600-B                                | 1321-3RA600-B      | 1321-3R600-C                                | 1321-3RA600-C      |
| 373 (500)              | 1321-3R600-B                                | 1321-3RA600-B      | 1321-3R600-C                                | 1321-3RA600-C      |
| 448 (600)              | 1321-3R750-B                                | 1321-3RA750-B      | 1321-3R750-C                                | 1321-3RA750-C      |
| 522 (700)              | 1321-3R850-B                                | 1321-3RA850-B      | 1321-3R850-C                                | 1321-3RA850-C      |
| 597 (800)              | 1321-3R1000-B                               | 1321-3RA1000-B     | 1321-3R1000-C                               | 1321-3RA1000-C     |

<sup>1</sup> Input Reactor on G Frame Drives Only.

### LINE REACTORS 500-600V AC INPUT

| Drive Ratings kW (HP) | Input or Output Line Reactor – 3% Impedance |                    | Input or Output Line Reactor – 5% Impedance |                    |
|-----------------------|---------------------------------------------|--------------------|---------------------------------------------|--------------------|
|                       | IP00 (Open Style)                           | IP11 (NEMA Type 1) | IP00 (Open Style)                           | IP11 (NEMA Type 1) |
| 0.75 (1)              | 1321-3R4-C                                  | 1321-3RA4-C        | 1321-3R4-D                                  | 1321-3RA4-D        |
| 1.5 (2)               | 1321-3R4-C                                  | 1321-3RA4-C        | 1321-3R4-D                                  | 1321-3RA4-D        |
| 2.2 (3)               | 1321-3R8-C                                  | 1321-3RA8-C        | 1321-3R8-D                                  | 1321-3RA8-D        |
| 3.7 (5)               | 1321-3R8-B                                  | 1321-3RA8-B        | 1321-3R8-C                                  | 1321-3RA8-C        |
| 5.5 (7.5)             | 1321-3R8-B                                  | 1321-3RA8-B        | 1321-3R8-C                                  | 1321-3RA8-C        |
| 7.5 (10)              | 1321-3R12-B                                 | 1321-3RA12-B       | 1321-3R12-C                                 | 1321-3RA12-C       |
| 11 (15)               | 1321-3R18-B                                 | 1321-3RA18-B       | 1321-3R18-C                                 | 1321-3RA18-C       |
| 15 (20)               | 1321-3R25-B                                 | 1321-3RA25-B       | 1321-3R25-C                                 | 1321-3RA25-C       |
| 18.5 (25)             | 1321-3R25-B                                 | 1321-3RA25-B       | 1321-3R25-C                                 | 1321-3RA25-C       |
| 22 (30)               | 1321-3R35-B                                 | 1321-3RA35-B       | 1321-3R35-C                                 | 1321-3RA35-C       |
| 30 (40)               | 1321-3R45-B                                 | 1321-3RA45-B       | 1321-3R45-C                                 | 1321-3RA45-C       |
| 37 (50)               | 1321-3R55-B                                 | 1321-3RA55-B       | 1321-3R55-C                                 | 1321-3RA55-C       |
| 45 (60)               | 1321-3R80-B                                 | 1321-3RA80-B       | 1321-3R80-C                                 | 1321-3RA80-C       |
| 56 (75)               | 1321-3R80-B                                 | 1321-3RA80-B       | 1321-3R80-C                                 | 1321-3RA80-C       |
| 75 (100)              | 1321-3R100-B                                | 1321-3RA100-B      | 1321-3R100-C                                | 1321-3RA100-C      |
| 95 (125)              | 1321-3R130-B                                | 1321-3RA130-B      | 1321-3R130-C                                | 1321-3RA130-C      |
| 112 (150)             | 1321-3R160-B                                | 1321-3RA160-B      | 1321-3R160-C                                | 1321-3RA160-C      |
| 149 (200)             | 1321-3R200-B                                | 1321-3RA200-B      | 1321-3R200-C                                | 1321-3RA200-C      |
| 187 (250)             | 1321-3RB250-B                               | 1321-3RA250-B      | 1321-3RB250-C                               | 1321-3RA250-C      |
| 224 (300)             | 1321-3RB320-B                               | 1321-3RA320-B      | 1321-3RB320-C                               | 1321-3RA320-C      |
| 261 (350)             | 1321-3RB400-B                               | 1321-3RA400-B      | 1321-3RB400-C                               | 1321-3RA400-C      |
| 298 (400)             | 1321-3RB400-B                               | 1321-3RA400-B      | 1321-3RB400-C                               | 1321-3RA400-C      |
| 336 (450)             | 1321-3R500-B                                | 1321-3RA500-B      | 1321-3R500-C                                | 1321-3RA500-C      |
| 373 (500)             | 1321-3R500-B                                | 1321-3RA500-B      | 1321-3R500-C                                | 1321-3RA500-C      |
| 448 (600)             | 1321-3R600-B                                | 1321-3RA600-B      | 1321-3R600-C                                | 1321-3RA600-C      |
| 485 (650)             | 1321-3R750-B                                | 1321-3RA750-B      | 1321-3R750-C                                | 1321-3RA750-C      |
| 522 (700)             | 1321-3R850-B                                | 1321-3RA850-B      | 1321-3R850-C                                | 1321-3RA850-C      |
| 597 (800)             | 1321-3R850-B                                | 1321-3RA850-B      | 1321-3R850-C                                | 1321-3RA850-C      |

### ISOLATION TRANSFORMERS

| Drive Ratings kW (HP) | 230V Primary & Secondary | 460V Primary & Secondary | 575V Primary & Secondary |
|-----------------------|--------------------------|--------------------------|--------------------------|
|                       | IP20 (NEMA Type 1)       | IP20 (NEMA Type 1)       | IP20 (NEMA Type 1)       |
| 0.37 (0.50)           | 1321-3TH005-AA           | 1321-3TH005-BB           | –                        |
| 0.56 (0.75)           | 1321-3TH005-AA           | 1321-3TH005-BB           | –                        |
| 0.75 (1)              | 1321-3TH005-AA           | 1321-3TH005-BB           | 1321-3TH005-CC           |
| 1.2 (1.5)             | 1321-3TH005-AA           | 1321-3TH005-BB           | –                        |
| 1.5 (2)               | 1321-3TH005-AA           | 1321-3TH005-BB           | 1321-3TH005-CC           |
| 2.2 (3)               | 1321-3TH005-AA           | 1321-3TH005-BB           | 1321-3TH005-CC           |
| 3.7 (5)               | 1321-3TH007-AA           | 1321-3TH007-BB           | 1321-3TH007-CC           |
| 5.5 (7.5)             | 1321-3TH011-AA           | 1321-3TH011-BB           | 1321-3TH011-CC           |
| 7.5 (10)              | 1321-3TH014-AA           | 1321-3TH014-BB           | 1321-3TH014-CC           |
| 11 (15)               | 1321-3TH020-AA           | 1321-3TH020-BB           | 1321-3TH020-CC           |
| 15 (20)               | 1321-3TH027-AA           | 1321-3TH027-BB           | 1321-3TH027-CC           |
| 18.5 (25)             | 1321-3TH034-AA           | 1321-3TH034-BB           | 1321-3TH034-CC           |
| 22 (30)               | 1321-3TH040-AA           | 1321-3TH040-BB           | 1321-3TH040-CC           |
| 30 (40)               | 1321-3TH051-AA           | 1321-3TH051-BB           | 1321-3TH051-CC           |
| 37 (50)               | 1321-3TH063-AA           | 1321-3TH063-BB           | 1321-3TH063-CC           |
| 45 (60)               | 1321-3TH075-AA           | 1321-3TH075-BB           | 1321-3TH075-CC           |
| 56 (75)               | 1321-3TH093-AA           | 1321-3TH093-BB           | 1321-3TH093-CC           |
| 75 (100)              | 1321-3TH118-AA           | 1321-3TH118-BB           | 1321-3TH118-CC           |
| 93 (125)              | 1321-3TH145-AA           | 1321-3TH145-BB           | 1321-3TH145-CC           |
| 112 (150)             | –                        | 1321-3TH175-BB           | 1321-3TH175-CC           |
| 149 (200)             | –                        | –                        | 1321-3TH220-CC           |
| 187 (250)             | –                        | –                        | 1321-3TH275-CC           |
| 224 (300)             | –                        | –                        | 1321-3TH330-CC           |
| 261 (350)             | –                        | –                        | 1321-3TH440-CC           |
| 298 (400)             | –                        | –                        | 1321-3TH440-CC           |
| 336 (450)             | –                        | –                        | 1321-3TH550-CC           |
| 373 (500)             | –                        | –                        | 1321-3TH550-CC           |
| 448 (600)             | –                        | –                        | 1321-3TH660-CC           |
| 485 (650)             | –                        | –                        | 1321-3TH770-CC           |
| 522 (700)             | –                        | –                        | 1321-3TH770-CC           |
| 597 (800)             | –                        | –                        | 1321-3TH880-CC           |



## 1336 IMPACT AC Drive Selection Guide

Notes

## Small in Size – Not in Applications or Performance

The Allen-Bradley 1336 family of AC drives offers advanced electronic technology. From the IGBT-based power structure to the advanced microprocessors, the 1336 variable frequency drives offer opportunities for increased productivity and energy savings.

### Material Handling

The 1336 IMPACT drive with Force Technology is well suited for some of the toughest material handling applications, such as sorting, diverting and load sharing conveyors. Varying load requirements, full torque at zero speed, and precise speed control are easily handled with the 1336 IMPACT drive. Features such as speed/torque selection, preset speeds, speed profiling, droop control, process trim, and linking capabilities provide application flexibility. Force Technology torque control offers virtually triplex operation by protecting against overcurrent trips due to shock loads often seen in conveyor applications. Also, the 1336 IMPACT drive has the high bandwidth and fast response required for cut-to-length applications.



### Extruders and Mixers

The 1336 IMPACT drive is designed to meet the most demanding requirements of extruders and similar applications. Constant torque from zero to full speed, more than rated torque at start-up, and virtually triplex operation are some of the specifications needed. The 1336 IMPACT drive provides overload capability of 150% current for 1 minute, with a programmable motor current limit up to 400%. With the optional encoder interface, the 1336 IMPACT drive provides speed regulation of 0.001%. This helps provide the precise speed control required for some mixing and metering applications. In addition, PI control and programmable process display give the drive flexibility to meet many critical process control needs.



### Special Applications

With flexible parameters and options, the 1336 IMPACT drive can be applied to a broad range of specialized applications, such as winders, machine tools and rapid-traverse. Programmable I/O function blocks, optional encoder feedback, speed control, torque control and communication options allow this drive to handle most specialized applications. In addition to the standard drive products, the OEM (Original Equipment Manufacturer) drives program allows OEM's to engineer the 1336 IMPACT drives into packages to handle special applications, such as crane/hoist, test stands and others.

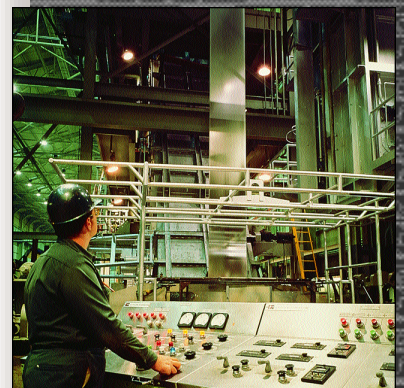

### Packaging and Design Flexibility

Additional options in the Configured Drives Program are available to help meet your application requirements. Most of the available options are completely pre-defined and manufacturing begins immediately after order entry. More complex option choices will require varying amounts of engineering and special handling, with delivery time varying by complexity. These offerings vary by country, contact your local Rockwell Automation office for availability.

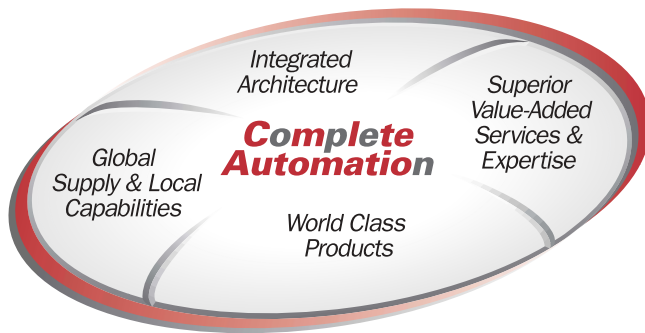

The 1336 IMPACT™ AC drive is a world class product that will help to provide you with a single solution for virtually all of your speed control requirements. Its common design and control interface functions will help save you time and money in set-up, integration, and maintenance of your automation system.

For Allen-Bradley Drives support, there are specialists at local sales offices and distributor locations across North America and around the world. We also offer Global Technical Services, specializing in a full spectrum of value-added services and expertise to help simplify maintenance and enhance productivity.

Rockwell Automation is committed to helping you meet ever-changing customer demands for more, less expensive product in less time. Our capabilities enable us to become your "Complete Automation™" partner.

*1336 FORCE, 1336 IMPACT, DriveExecutive, DriveTools32, Flex, Force Technology, PLC, SLC 500, SCANport, Complete Automation and the Complete Automation graphic are trademarks of Rockwell Automation.*

*DeviceNet is a trademark of the Open DeviceNet Vendor Association.  
ControlNet is a trademark of ControlNet International, Ltd.*

For technical information refer to our web site: [www.ab.com/drives](http://www.ab.com/drives)

[www.rockwellautomation.com](http://www.rockwellautomation.com)

#### Power, Control and Information Solutions Headquarters

Americas: Rockwell Automation, 1201 South Second Street, Milwaukee, WI 53204-2496 USA, Tel: (1) 414.382.2000, Fax: (1) 414.382.4444  
Europe/Middle East/Africa: Rockwell Automation, Vorstlaan/Boulevard du Souverain 36, 1170 Brussels, Belgium, Tel: (32) 2 663 0600, Fax: (32) 2 663 0640  
Asia Pacific: Rockwell Automation, Level 14, Core F, Cyberport 3, 100 Cyberport Road, Hong Kong, Tel: (852) 2887 4788, Fax: (852) 2508 1846