



Allen-Bradley

**1336 FORCE™
ControlNet™**

*Firmware Rev 1.02
Compatible with
ControlNet Version 1.5*

efesotomasyon.com

User Manual

efesotomasyon.com

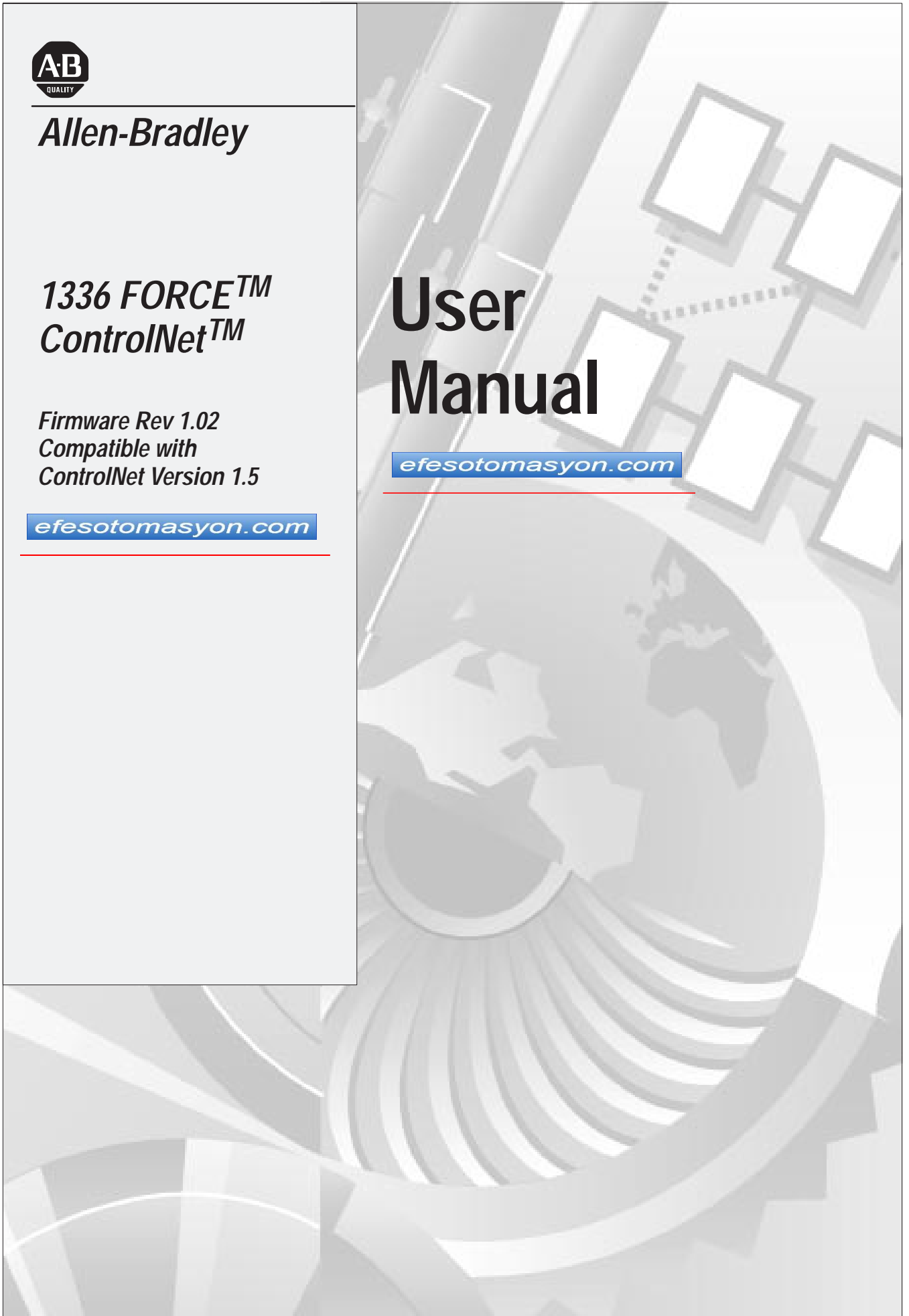

Important User Information

Solid state equipment has operational characteristics differing from those of electromechanical equipment. “Safety Guidelines for the Application, Installation and Maintenance of Solid State Controls” (Publication SGI-1.1) describes some important differences between solid state equipment and hard-wired electromechanical devices. Because of this difference, and also because of the wide variety of uses for solid state equipment, all persons responsible for applying this equipment must satisfy themselves that each intended application of this equipment is acceptable.

In no event will the Allen-Bradley Company be responsible or liable for indirect or consequential damages resulting from the use or application of this equipment.

The examples and diagrams in this manual are included solely for illustrative purposes. Because of the many variables and requirements associated with any particular installation, the Allen-Bradley Company cannot assume responsibility or liability for actual use based on the examples and diagrams.

No patent liability is assumed by Allen-Bradley Company with respect to use of information, circuits, equipment, or software described in this manual.

Reproduction of the contents of this manual, in whole or in part, without written permission of the Allen-Bradley Company is prohibited.

Throughout this manual we use notes to make you aware of safety considerations.



ATTENTION: Identifies information about practices or circumstances that can lead to personal injury or death, property damage, or economic loss.

Attentions help you:

- identify a hazard
- avoid the hazard
- recognize the consequences

Important: Identifies information that is especially important for successful application and understanding of the product.

Preface

Who Should Use this Manual	P-1
What Is the ControlNet Adapter Board	P-1
Purpose of this Manual	P-2
Contents of this Manual	P-2
Related Documentation	P-3
Terms and Abbreviations	P-4
Common Techniques Used in this Manual	P-6
Allen-Bradley Support	P-7
Local Product Support	P-7
Technical Product Assistance	P-7
Catalog Number Description	P-7

Installation and Wiring

Chapter 1

Chapter Objectives	1-1
Mounting the ControlNet Adapter Board	1-2
Setting Your Input Voltage	1-3
Writing to BRAM	1-3
Terminal Block Locations	1-3
Discrete I/O	1-4
Discrete Outputs	1-4
Discrete Inputs	1-4
Analog I/O Connections	1-6
Analog Inputs	1-6
Analog Outputs	1-7
Determining Your Communications Configuration	1-8
Fiber Optic Cable Installation	1-8
Cable Types	1-9
Associated Hardware	1-9

Starting Up

Chapter 2

Chapter Objectives	2-1
Setting the DIP Switches	2-1
Switch settings for Node Address	2-2
Setting Up the Analog I/O	2-4
Understanding the Scale and Offset Parameters for Input	2-6
Understanding the Scale and Offset Parameters for Output	2-7
Using the SCANport Capabilities	2-9
Pre-Configured Links	2-9

Scheduled Data Transfer**Chapter 3**

Chapter Objectives	3-1
Understanding ControlNet Communications	3-1
Transferring Data Using Discrete Data Transfer	3-1
Discrete PLC Programming	3-3
Scaling	3-4
Discrete I/O Program Example	3-4

Unscheduled Messaging**Chapter 4**

Chapter Objectives	4-1
ControlNet Features	4-1
Message Instruction	4-2
ControlNet Command Set	4-3
Emulated Block Transfer	4-7
Block Transfer Status Word	4-7
Message Summary	4-8
Parameter Value Read	4-9
Continuous Parameter Value Read	4-11
Scattered Parameter Value Read	4-13
Parameter Read Full	4-15
Parameter Value Write	4-18
Continuous Parameter Value Write	4-19
Scattered Parameter Value Write	4-21
Fault Clear/Reset	4-23
Trip Fault Queue Number	4-25
Fault Entry Read Full	4-26
Warning Clear	4-28
Warning Queue Read Full	4-30
Save/Recall/Initialize	4-32
Link Parameter Read	4-34
Continuous Parameter Link Read	4-35
Scattered Parameter Link Read	4-37
Link Parameter Write	4-39
Continuous Parameter Link Write	4-40
Scattered Parameter Link Write	4-42
Parameter Link Clear	4-44
User Text String Read	4-45
User Text String Write	4-47
Real Time Clock Data Read	4-49
Real Time Clock Data Write	4-51
Run Time Accumulator Data Read	4-53
Clear Run Time Accumulator	4-55
Reference Time Stamp Data Read	4-56
Reference Time Stamp Data Write	4-58
Load Clock Info Reference Stamp	4-60

	Number of Trends Available	4-61
	Maximum Trend Size Available	4-62
	Trend Command	4-63
	Trend Status	4-65
	Setup Data Full	4-67
	All Info	4-70
	Trigger Time	4-73
	Run File Data	4-75
	Stored File Data	4-78
	Trend Parameter Definition	4-80
	Trend Triggered Setup Parameter Values	4-82
Drive Resources		
	Chapter 5	
	Chapter Objectives	5-1
	Using the SCANport Capabilities	5-1
	Understanding the Logic Command Parameter	5-1
	Configuring the SCANport Controls	5-5
	Determining Function Ownership	5-6
	Masking Control Functions	5-7
	Setting the Loss of Communications Fault	5-8
	Viewing the SCANport Fault Status	5-9
	Using the SCANport Image	5-9
	Setting Up the Analog I/O Parameters	5-10
	Understanding Function Blocks	5-11
	Using System Resources	5-14
	Chapter 6	
	Chapter Objectives	6-1
	BRAM Functions	6-1
	Parameter Listing	6-2
	Parameter Files and Groups	6-4
	File 1 – Startup	6-5
	File 2 – Communications I/O	6-6
	File 3 – Velocity Torque	6-7
	File 4 – Diagnostics	6-9
	Parameter Conventions	6-11
	Parameter Descriptions	6-12
	Chapter 7	
	Chapter Objectives	7-1
	Fault and Status LEDs	7-1
	Application Processor (AP) Status D1 and D2	7-2
	Domino Processor (DP) Status D3 and D6	7-3
	ControlNet Adapter Status D4, D5, D7, D9, and D11	7-3
Troubleshooting		

	Primary Channel Status D8, D10, and D12	
	Redundant Channel Status D13, D14, and D15	7-5
	Fault Queues	7-5
	Faults	7-5
	Communication Fault Reporting and Handling	7-6
	Fault Code Descriptions	7-9
	Fault Displays	7-9
Using the Trend Features	Chapter 8	
	Setting Up Trending	8-1
	Selecting the Parameter to Sample	8-1
	Setting the Trigger Condition	8-2
	Setting the Sample Rate	8-4
	Setting the Number of Post Samples	8-5
	Setting the Trend Mode and Selection	8-6
	Trending Status	8-7
	Looking at the Output	8-8
Specifications	Chapter 9	
	Chapter Objectives	9-1
	Specifications	9-1
	Software Block Diagram	9-3

This Page Intentionally Blank

Preface

efesotomasyon.com

Read this preface to familiarize yourself with this manual. This preface covers the following topics:

- who should use this manual
- an overview of the ControlNet™ Adapter Board
- the purpose of this manual
- terms and abbreviations
- conventions used in this manual
- Allen-Bradley support

Who Should Use this Manual

Use this manual if you are responsible for installing, wiring, starting up, programming, or troubleshooting control systems that use the ControlNet Adapter Board.

To use this product, you should be able to program and operate an Allen-Bradley PLC and/or DriveTools. In particular, you need to be familiar with ControlNet concepts and configurations, and be able to program messaging instructions.

The ControlNet board contains primarily the same functionality of the PLC Comm Board except as shown in the following matrix:

Function:	PLC Comm Board:	ControlNet Adapter Board:
Messaging	Via Data Highway Plus	Via ControlNet
Discrete Data Transfer	1/4, 1/2, full rack via RIO	Full rack via ControlNet
Communication Channels	2 independently configurable	1 channel with redundancy

What Is the ControlNet Adapter Board

You can add a ControlNet Adapter Board to your 1336 FORCE system to expand the communications capabilities. The following are the major features of the CNA Board:

- Direct Connection to ControlNet V 1.5 Network providing Discrete I/O transfer and message blocks.
- support for up to five SCANport™ devices that allow you to connect to a wide range of Allen-Bradley devices
- four analog inputs and four analog outputs
- function block programming to help you customize the way your drive operates

- trending capabilities as a diagnostic tool to allow you to capture data values for a parameter
- a 32-event fault and warning queue

Purpose of this Manual

This manual:

- provides planning, installation, and wiring information for the ControlNet Adapter Board
- explains the procedures you need to mount and configure your CNA Board
- describes the available parameters and block messaging instructions
- provides information to help you troubleshoot your CNA Board

Contents of this Manual

This manual contains the following information:

Chapter:	Title:	Contents:
	Preface	Describes the purpose, background, and scope of this manual as well as an overview of this product.
1	Installing and Wiring Your ControlNet Adapter Board	Provides procedures for installing and wiring your CNA Board.
2	Starting Up	Provides information for starting up your system.
3	Using Scheduled Discrete Data Transfer	Provides information about using ControlNet communications to transfer scheduled discrete data.
4	Using Unscheduled Messaging	Provides information on emulated block transfer messaging.
5	Understanding the Resources of Your Drive.	Provides an overview of the function block software and the available system resources.
6	Parameters	Provides information about the parameters that are specific to the ControlNet Adapter Board.
7	Troubleshooting	Explains how to interpret and correct problems with your ControlNet Adapter Board.
8	Using the Trending Features	Provides step-by-step instructions for using trending for diagnostic purposes.
9	Specifications and Supplemental Information	Provides specifications and supplemental information including a parameter cross reference by number.



ATTENTION: This board contains ESD (electrostatic discharge) sensitive parts and assemblies. Static control precautions are required when installing, testing, servicing, or repairing this assembly. Component damage may result if you do not follow ESD control precautions. If you are not familiar with static control procedures, refer to *Guarding Against Electrostatic Damage*, Allen-Bradley Publication 8000-4.5.2, or any other applicable ESD protection handbook.

ATTENTION: Only personnel familiar with SCANport devices and associated machinery should plan or implement the installation, start-up, or subsequent troubleshooting of this board. Failure to comply may result in personnel injury and/or equipment damage.

Related Documentation

The following documents contain additional information concerning related Allen-Bradley products. To obtain a copy, contact your local Allen-Bradley office or distributor.



For:	Read this document:	Document number:
A description of function blocks and function block programming	1336 FORCE™ PLC Communications Adapter Function Block Programming Manual	1336 FORCE-5.9
Information to help you install, program, start up, and maintain the 1336 FORCE digital AC drive	1336 FORCE™ Field Oriented Control User Manual	1336 FORCE-5.12
In-depth information on grounding and wiring Allen-Bradley programmable controllers	Allen-Bradley Programmable Controller Grounding and Wiring Guidelines	1770-4.1*
A description on how to install a PLC-5® system	PLC-5 Family Programmable Controllers Hardware Installation Manual	1785-6.6.1*
A description of important differences between solid-state programmable controller products and hard-wired electromechanical devices	Application Considerations for Solid-State Controls	SIG-1.1
An article on wire sizes and types for grounding electrical equipment	National Electrical Code	Published by the National Fire Protection Association
A complete listing of current Allen-Bradley documentation, including ordering instructions. Also indicates whether the documents are available on CD-ROM or in multi-languages.	Allen-Bradley Publication Index	SD499
A glossary of industrial automation terms and abbreviations	Allen-Bradley Industrial Automation Glossary	AG-7.1
A glossary of ControlNet terms and abbreviations	ControlNet Network System Overview	1786-2.9*
PLC-5 Programmable Controllers	ControlNet PLC-5 User Manual 1.5	1785-6.5.22

Terms and Abbreviations

The following terms and abbreviations are specific to this product. For a complete listing of Allen-Bradley terminology, refer to the *Allen-Bradley Industrial Automation Glossary*.

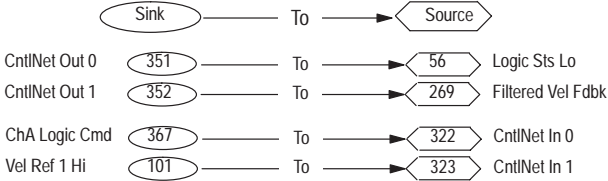
This term:	Has the following definition:
CNA Board	ControlNet Adapter Board
BRAM	See Non-volatile memory.
Configuration parameter	A configuration parameter is a sink parameter whose value may be changed while the drive is in operation. Configuration parameters are used to input reference and feedback information to the drive and to provide monitoring points for control signals. Refer to the 1336 FORCE user manual for a description of source and sink parameters.
Drive units	Drive units are the actual values of the parameters as stored within the drive parameter table. The drive units may be converted to engineering units or to hexadecimal for display, or may be displayed directly in drive units. All internal values in the drive are in terms of per unit numbering.
Emulated Block Transfer	The ControlNet network emulates the “block transfer” functions of the 1336 FORCE drive via messaging. The 1336 FORCE drive does not support CI/O (the newest method of ControlNet block transfer).
Engineering units	Engineering units is a label given to parameter data that specifies what units are to be used to display the parameter value.
Function blocks	A function block is a firmware subroutine that is stored in memory within the ControlNet Adapter Board. The ControlNet Adapter Board provides 28 different function block types. By combining function blocks, you can customize the way your drive operates. Refer to the 1336 FORCE function block programming manual for more information about function blocks.
NUI (Network Update Interval)	Actual update time, which is a user specified interval which is a power of two multiple of the NUT (Network Update Time).
NUT (Network Update Time)	Repetitive time interval in which data can be sent on the ControlNet network.
PCCC	Programmable Controller Communications Commands. An application-level command set that Allen-Bradley programmable controllers use to communicate across networks.
Scheduled transfers	Deterministic and repeatable transfers that are continuous and asynchronous to the ladder-logic program scan.
Unscheduled transfers	Non-deterministic data transfers through ladder-initiated communication or programming devices.
Class 1 Data Connection	See “Scheduled transfers”.
Class 3 Data Connection	See “Unscheduled transfers”.

This term:	Has the following definition:
Links	<p>A link is a software connection between a linkable sink parameter and a source parameter. You can use links to transfer data from the source parameter to a linkable sink parameter. Your 1336 FORCE user manual provides a list of linkable sink parameters.</p> <p>The ControlNet Adapter Board allows up to 50 links in addition to 4 analog output links. You can only program links when the drive is not running. Links are stored in BRAM and established at power up, BRAM recall, and/or system reset.</p> <p>There are two types of links:</p> <ul style="list-style-type: none"> •User Link — A user link is a software connection that you establish. You can change these links as needed. •Default Link — A default link is a software connection between two parameters that is made when the drive is initialized. <p style="text-align: center;">Default Links</p>  <pre> graph LR Sink([Sink]) -- To --> Source{{Source}} CntlNetOut0([CntlNet Out 0 351]) -- To --> LogicSlsLo{{Logic Sls Lo 56}} CntlNetOut1([CntlNet Out 1 352]) -- To --> FilteredVelFdbk{{Filtered Vel Fdbk 269}} ChALogicCmd([ChA Logic Cmd 367]) -- To --> CntlNetIn0{{CntlNet In 0 322}} VelRef1Hi([Vel Ref 1 Hi 101]) -- To --> CntlNetIn1{{CntlNet In 1 323}} </pre>
Mask parameters	<p>Through the SCANport interface, up to five different SCANport adapters can control the 1336 FORCE. With this flexibility, conflicts are inherent. The ControlNet Adapter Board allows you to make functional masks. At each port, you can selectively lock out functions such as start, jog, and drive direction as well as many fault interlocks by using mask parameters to select the allowable functions for each port.</p>
Non-volatile memory	<p>Non-volatile memory is data memory in the drive that retains the values of all data even when power is disconnected from the drive. BRAM (Battery backed Random Access Memory) chips are used for the non-volatile memory to store some of the drive parameters, links, and user text.</p>
Owner parameters	<p>The ControlNet Adapter Board allows one or more control devices or adapters to own start, jog, direction, and other control functions. To avoid conflict, some owners are exclusive. For example, only one device can issue a forward direction speed command. Others have multiple control. For example, all devices can jog the drive in the forward direction, but only at a set speed. Devices can, for example, jog the drive in the forward direction only if the jog mask parameter allows for it.</p>
Parameter entry	<p>A parameter entry refers to the information stored in the drive that contains the parameter number, parameter data, and all other information related to the specific parameter.</p>
Parameter table	<p>A parameter table is a table of parameter entries for all configuration sink and source parameters in the drive.</p>

This term:	Has the following definition:
Per-unit numbering	Per-unit numbering is a numbering system that defines a specific numeric value as representing 100% of a particular quantity being measured. The number 4096 is used in many places in the drive to represent one per unit.
Sink parameters (Read and Write parameters)	Sink parameters accept data from other parameters. The drive then uses this data to perform the desired functions. An example of a sink parameter is the external velocity reference parameter that accepts a speed reference from a device such as a PLC. Throughout this manual, the following symbol indicates a sink parameter: 
Source parameters (Read-only parameters)	Source parameters provide real-time information that is available for other devices to use. These devices can include PLC controllers, operator interface devices, programming terminals, etc. Throughout this manual, the following symbol indicates a source parameter: 
Trending	Trending is a diagnostic tool used to capture and retain an input parameter data value (such as velocity feedback) until a trigger condition (drive fault or malfunction condition) halts or suspends sampling.

Common Techniques Used in this Manual

The following conventions are used throughout this manual:

- Bulleted lists provide information, not procedural steps.
- Numbered lists provide sequential steps or hierarchical information.

Allen-Bradley Support

Allen-Bradley offers support services worldwide, with over 75 Sales/Support Offices, 512 authorized Distributors and 260 authorized Systems Integrators located throughout the United States alone, plus Allen-Bradley representatives in every major country in the world.

Local Product Support

Contact your local Allen-Bradley representative for:

- sales and order support
- product technical training
- warranty support
- support service agreements

Technical Product Assistance

If you need to contact Allen-Bradley for technical assistance, please review the information in the *Troubleshooting* chapter first. If you are still having problems, then call your local Allen-Bradley representative.

Catalog Number Description

A language module is located on each ControlNet Adapter Board. Catalog numbers identifying the language modules are as follows:

1336T

1336T = Field Installed
(Blank) = Factory Installed

GT3EN

GT3EN = English Version
GT3EN = English Version

This Page Intentionally Blank

Installing and Wiring Your ControlNet Adapter Board

Chapter Objectives

Chapter 1 provides information so that you can:

- mount the ControlNet Adapter Board
- configure and connect the communications
- configure and set up the discrete inputs and analog I/O

Important: The installation and wiring information in this manual is specific to the ControlNet Adapter Board. For information about mounting the drive, connecting the motor leads, or connecting the power, refer to the 1336 FORCE user manual.

The following illustration shows the ControlNet Adapter Board.

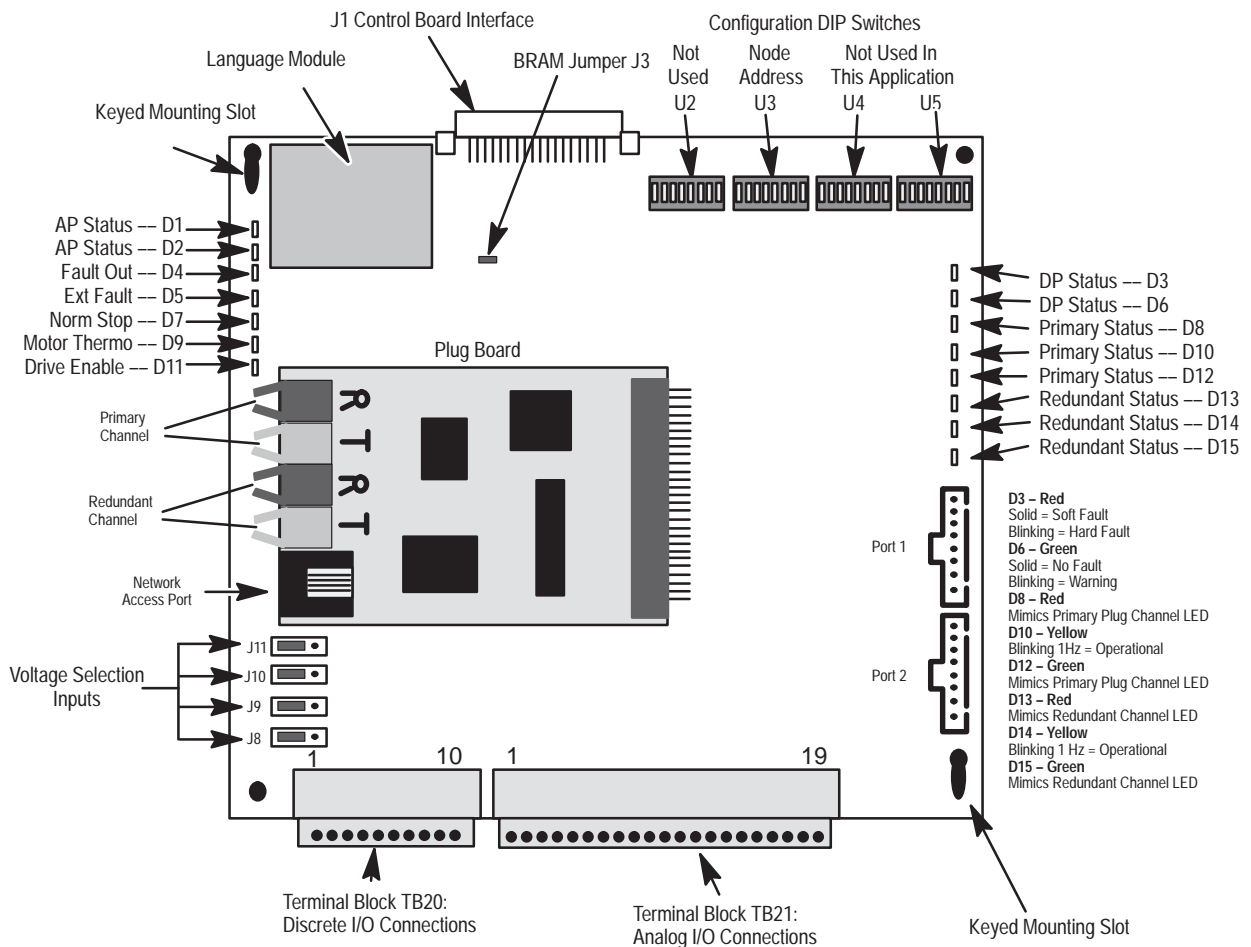

Mounting the ControlNet Adapter Board

To mount your ControlNet Adapter Board on to your 1336 FORCE, you need to:



ATTENTION: To avoid a shock hazard, assure that all power to the drive has been removed before proceeding.

1. Place the CNA Board over the keyed mounting slots.
2. Slide the board up into the main control board connector J1.
3. Secure the board to the 1336 FORCE mounting plate using the two Phillips-head screws that are provided with the kit.
4. Connect primary and redundant ControlNet channels at the fiber optic connector. You must maintain a minimum bend radius on the fiber optic cable of 1 inch at all times. If you cannot maintain this bend radius, remove the plastic strain relief following the instructions for Frame D drives detailed on page 1-8. Using the ControlNet Adapter Board on a Frame D drive, always requires the removal of the cable strain relief. See page 1-8 for special cable instructions for D Frame drives.

Setting Your Input Voltage

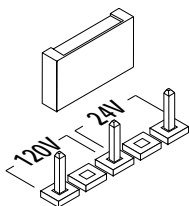

To select your input voltage, you need to set the discrete I/O jumpers.



ATTENTION: To avoid damaging the CNA Board, you must set all discrete I/O jumpers to the same input voltage applied to the ControlNet Adapter Board. The voltage must be either 24V DC or 120V AC.

Set this discrete I/O jumper:	To set this input:	To either:
DR EN	Drive Enable	24V dc or 120V ac
M THERM	Motor Thermoguard	24V dc or 120V ac
N STOP	Normal Stop	24V dc or 120V ac
X FLT	External Fault	24V dc or 120V ac

Writing to BRAM

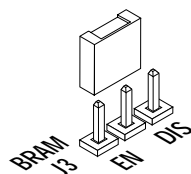

You can use jumper J3 on the ControlNet Adapter Board to either allow (enable) or not allow (disable) writes to Battery backed Random Access Memory (BRAM).

Choose:	To:
EN (Enabled)	Allow writes to BRAM.
DIS (Disabled)	Not allow writes to BRAM.

Terminal Block Locations

Two terminal blocks, TB20 and TB21, are provided at the bottom of the ControlNet Adapter Board for discrete and analog I/O wiring.



To make the connections more easily, you can pull apart the terminal blocks when connecting the cables.

Both terminal blocks accept a maximum wire size of 3.3 mm² (12 AWG) and a minimum wire size of 0.60 mm² (30 AWG). Maximum torque is 0.79 N-m (7 lb-in). Recommended control signal wire is:

Belden number:	Description for equivalent:
8760	0.750 mm ² (18 AWG), twisted pair, shielded
8770	0.750 mm ² (18 AWG), 3-conductor, shielded
9460	0.750 mm ² (18 AWG), twisted pair, shielded

Discrete I/O

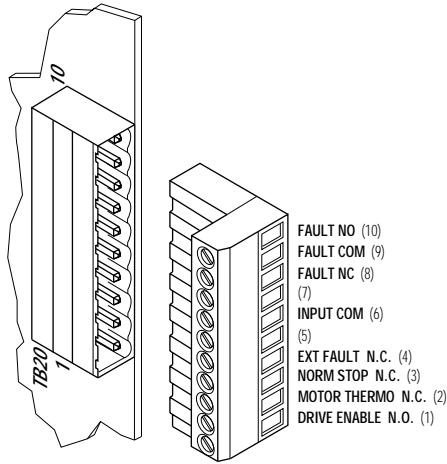

Terminal block TB20 provides the discrete I/O capabilities.

Discrete Outputs

Fault outputs from the 1336 FORCE are supplied at terminal block TB20 on the ControlNet Adapter Board. Fault outputs provide warning or fault signals based on drive status.

The Fault NC, Fault Com, and Fault NO outputs are relay contacts that provide fault signals. If a contact is closed (energized), then there is no fault. If a contact is open, there is a fault.

The following values are the contact ratings for the Fault NC, Fault Com, and Fault NO relays:

- 2A at 115V AC
- 2A at 30V DC

The typical digital output connections can be shown as follows:

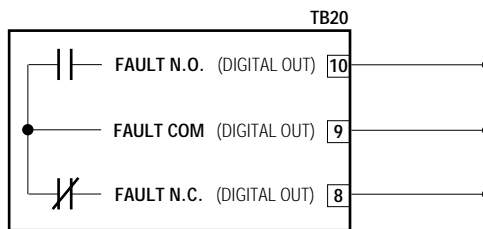

Discrete Inputs

Discrete inputs to the 1336 FORCE are supplied through the ControlNet Adapter Board at terminal block TB20. Discrete inputs enable and stop the drive as well as providing checks on drive and motor operation.

The typical digital input connections when using an external power source can be shown as follows:

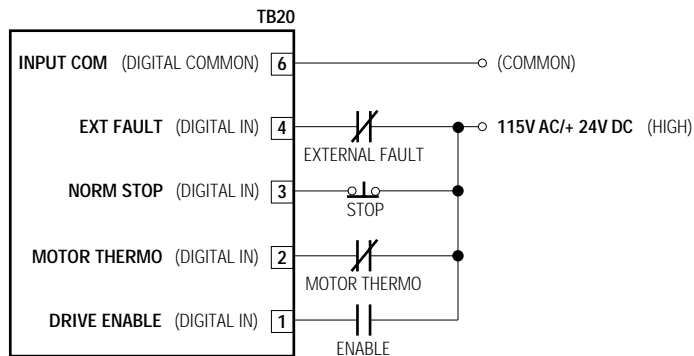

The following are the signals that may be used:

This signal:	Has the following meaning:
DRIVE ENABLE	A drive enable signal must be present before the drive will acknowledge a start command. If LED D11 drive enable on the CNA Board is illuminated, the drive has received an enable signal allowing drive logic to accept a start command.
MOTOR THERMO	<p>A motor thermo signal allows you to connect an NC motor thermal switch to the 1336 FORCE. Motor Thermo LED D9 on the CNA Board illuminates if a motor over-temperature condition occurs. The drive issues a fault or warning based on the fault configuration defined by VP Fault Select (parameter 88) and VP Warn Select (parameter 89).</p> <hr/> <p> ATTENTION: The drive start/stop control circuitry includes solid-state components. If hazards due to accidental contact with moving machinery or unintentional flow of liquid, gas, or solids exist, an additional hardwired stop circuit is required to remove ac line power to the drive. When you remove ac input power, there is loss of inherent regenerative braking effect and the motor coasts to a stop. An auxiliary braking method may be required.</p>
NORM STOP	A normal stop signal specifies an NC maintained stop input that stops the drive according to the stop mode you specified using parameter 59. The drive responds the same way it would if the stop bit were set in any logic command. When a stop signal is present, the Norm Stop LED D7 on the CNA Board is illuminated, and the drive cannot run until the stop signal is removed.
EXT FAULT	An Ext Fault signal allows you to wire an external signal into an AC input 1336 FORCE. If external fault input voltage is removed, the External Fault LED D5 on the CNA Board is illuminated. The drive then issues a fault or warning based on the fault configuration defined by parameters 88 and 89. (Ext Fault is not available on common DC bus input drives.)

Analog I/O Connections

You can access the analog I/O connections at terminal block TB21. There are four analog inputs and four analog outputs. Each of the analog I/O parameter have scale and offset parameters. The analog inputs can be linked to any linkable sink parameter, and the analog outputs can receive information from any parameter in the drive. The drive increments the analog I/O every two milliseconds.

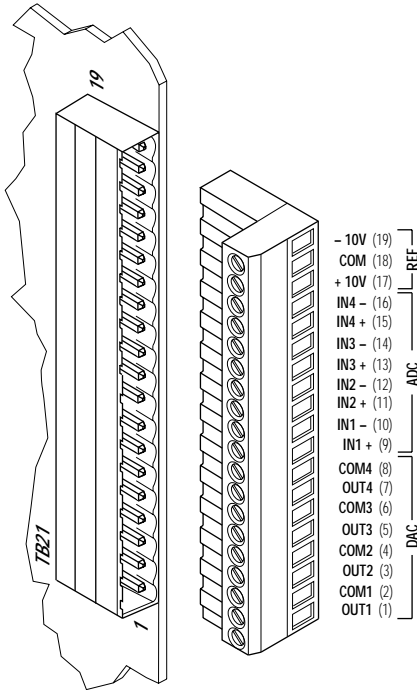

Analog Inputs

The ControlNet Adapter Board has 4 analog inputs that have a range of $\pm 10V$ and a digital resolution of 12 bits. These inputs are differential inputs with noise rejection filtering. Each input has a gain and offset adjustment.

The A/D converter is a 12-bit device where an input value of +10V results in a digital value of 2048. Likewise, an input value of -10V results in a digital output value of -2048.

Chapter 2, *Starting Up*, describes the parameters associated with scaling analog values.

For an analog input to control a function, you need to:

1. Link the analog input parameter(s) to a parameter such as velocity reference.
2. Set up the scale and offset parameters associated with that analog input parameter.

The typical analog input connections for unidirectional operation are shown as follows:

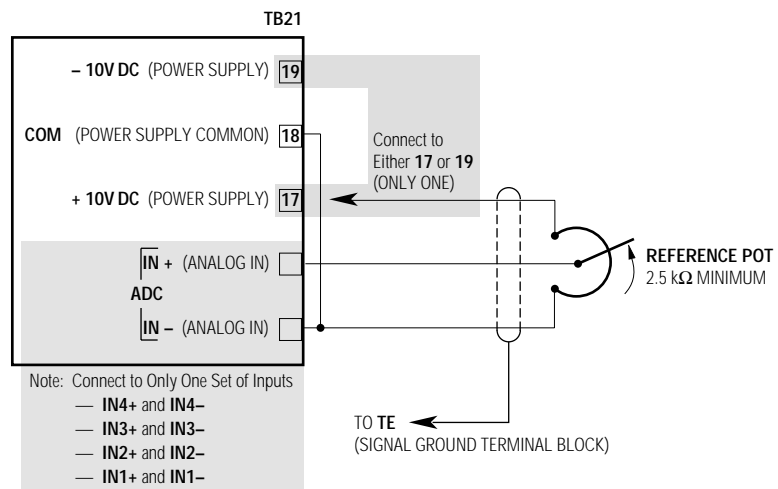

The typical analog input connections for bidirectional operation can be shown as follows:

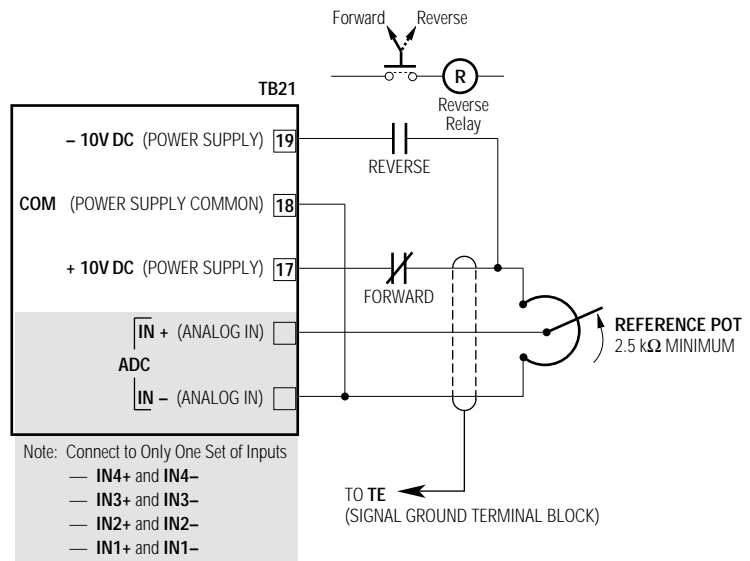

The following table shows the analog input specifications:

Specifications:	Value:
Differential impedance	Greater than 1 Ohm
Single ended impedance	20K Ohm
Maximum voltage	±10V

Analog Outputs

The ControlNet Adapter Board has 4 analog outputs that have a range of ±10V and a digital resolution of 12 bits. Chapter 2, *Starting Up*, describes the parameters associated with scaling analog values.

The typical analog output connections can be shown as follows:

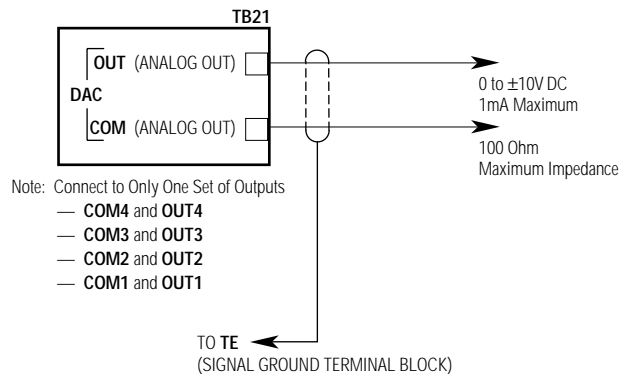

Determining Your Communications Configuration

The CNA Board provides a single ControlNet channel with a redundant connection available.

You can use the DIP switch U3 to configure the primary and redundant channel node address.



Chapter 2, *Starting Up*, provides information for setting the ControlNet Node Address using DIP switch U3.

Fiber Optic Cable Installation

If you are installing the fiber optic cable for ControlNet for the first time, or are removing and reinstalling the cable, special note should be taken of the following:

1. You must maintain a minimum cable bend radius of 1 inch at all times. If it is impossible to maintain this bend radius due to cabinet constraints, you must remove the cable strain relief to maintain bend radius as detailed in step 2. Follow step 3 in determining cable orientation with the strain relief removed.
2. If you are installing a new cable, it will be necessary to remove the strain relief/latching cover (as shown in the following figure) before attempting to plug the cable into the ControlNet board. The cover can be removed by squeezing the two latches inward and lifting the upper half off from the cable end (bottom) of the cover assembly.

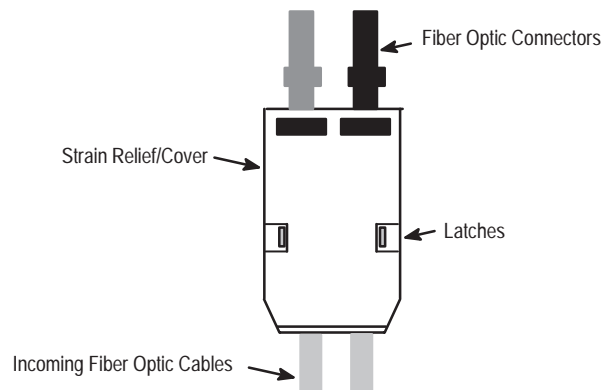

3. When installing (or reinstalling) the loose fiber optic cables, it will be necessary to determine the correct orientation of the cable connectors to establish ControlNet communication. The blue connector must be plugged into the dark grey connection on the board. The black connector plugs into the light grey connection on the board. The cable with the black connector is the transmit cable (TX) and the cable with the blue connector is the receive (RX) cable. Reset the drive and the ControlNet system should be ready to operate.

4. On some applications, it may be necessary to provide some form of cable support after removing the strain relief. If your application involves a long cable droop, or a heavy unsupported wire bundle, it is recommended you zip tie the fiber optic cable at a point that will prevent the weight of the cable from being solely supported by the plug in connectors.
5. If the cable is kinked or nicked during installation, it **MUST** be replaced. A kinked or damaged cable greatly reduces signal strength and could cause the drive to fault.

Cable Type – Recommended cables are shown in the following table. These cables are available in precut, popular lengths for ease of use.

Micron Fiber Optic Cable Selection

Description	Catalog Number
200 Micron Cable Assembly 10 meters	1786 – FS10
200 Micron Cable Assembly 20 meters	1786 – FS20
200 Micron Cable Assembly 60 meters	1786 – FS60
200 Micron Cable Assembly 100 meters	1786 – FS100
200 Micron Cable Assembly 200 meters	1786 – FS200
200 Micron Cable Assembly 300 meters	1786 – FS300

IMPORTANT: Only use cables that are approved for ControlNet Applications. Refer to Bulletin 1786 ControlNet documentation for details.

Associated Hardware – The 1786-RPA module converts the coax cable through a CNet coax tap to up to four of the 1786-RPFS modules. The 1786 RPFS X has two connectors to receive the 200 Micron cable. The Drive ControlNet adapter board also has two connectors to receive the 200 Micron cable.

Module Selection

Description	Catalog Number
ControlNet Modular Repeater Adapter	1786 – RPA
Short Distance Fiber Module – 300 meters	1786 – RPFS

Note: The 1786-RPA must be powered from a 24 volt power supply

For additional information on repeater modules refer to the following publications:

1786-2.12 ControlNet Network System Overview

1786-5.12 ControlNet Modular Repeater Short-Distance Fiber Modular Installation Instructions.

1786-5.13 ControlNet Modular Repeater Adapter Installation Instructions.

This Page Intentionally Blank

Starting Up

Chapter Objectives

Chapter 2 provides the following information:

- setting the DIP switch to configure the Primary and Redundant channels
- setting up the analog I/O
- a description of the SCANport capabilities
- a description of the pre-configured links

Setting the DIP Switches

The ControlNet Adapter Board contains four address switches . Only switch U3 is used on the CNA board to set the Node Address. Switches U2, U4 and U5 are NOT used in this application. Changes to switch settings will not take effect until power is re-applied.



ATTENTION: Use a blunt, pointed instrument (such as a ball point pen) to set DIP switches. Do not use a pencil. Pencil lead (graphite) may damage switch assemblies.



ATTENTION: The CNA Board uses both input and output image table words for drive control. The CNA Board is not compatible with complementary I/O configurations. Failure to check connections and switch settings for application compatibility when configuring the CNA Board could result in personal injury and /or equipment damage due to unintended or undesirable drive or process equipment operation.



If you encounter any operating faults once switch settings have been applied, refer to Chapter 7, *Troubleshooting*.

NOTE: DIP Switch orientation on the CNA board is as follows:

CLOSED = “ON” = “1”

OPEN = “OFF” = “0”



Switch settings for Node Address (switch U6):

Switch positions 2-8 determine the node address of the CNA adapter. Refer to Table 2.A for details. Node Address position 1 is reserved for the PLC.

Table 2.A Switch settings for Node Address (U3)

ControlNet Address	Switch positions							
	1	2	3	4	5	6	7	8
1*	Off	Off	Off	Off	Off	Off	Off	On
2	Off	Off	Off	Off	Off	Off	On	Off
3	Off	Off	Off	Off	Off	Off	On	On
4	Off	Off	Off	Off	Off	On	Off	Off
5	Off	Off	Off	Off	Off	On	Off	On
6	Off	Off	Off	Off	Off	On	On	Off
7	Off	Off	Off	Off	Off	On	On	On
8	Off	Off	Off	Off	On	Off	Off	Off
9	Off	Off	Off	Off	On	Off	Off	On
10	Off	Off	Off	Off	On	Off	On	Off
11	Off	Off	Off	Off	On	Off	On	On
12	Off	Off	Off	Off	On	On	Off	Off
13	Off	Off	Off	Off	On	On	Off	On
14	Off	Off	Off	Off	On	On	On	Off
15	Off	Off	Off	Off	On	On	On	On
16	Off	Off	Off	On	Off	Off	Off	Off
17	Off	Off	Off	On	Off	Off	Off	On
18	Off	Off	Off	On	Off	Off	On	Off
19	Off	Off	Off	On	Off	Off	On	On
20	Off	Off	Off	On	Off	On	Off	Off
21	Off	Off	Off	On	Off	On	Off	On
22	Off	Off	Off	On	Off	On	On	Off
23	Off	Off	Off	On	Off	On	On	On
24	Off	Off	Off	On	On	Off	Off	Off
25	Off	Off	Off	On	On	Off	Off	On
26	Off	Off	Off	On	On	Off	On	Off
27	Off	Off	Off	On	On	Off	On	On
28	Off	Off	Off	On	On	On	Off	Off
29	Off	Off	Off	On	On	On	Off	On
30	Off	Off	Off	On	On	On	On	Off
31	Off	Off	Off	On	On	On	On	On
32	Off	Off	On	Off	Off	Off	Off	Off
33	Off	Off	On	Off	Off	Off	Off	On
34	Off	Off	On	Off	Off	Off	On	Off
35	Off	Off	On	Off	Off	Off	On	On
36	Off	Off	On	Off	Off	On	Off	Off
37	Off	Off	On	Off	Off	On	Off	On
38	Off	Off	On	Off	Off	On	On	Off
39	Off	Off	On	Off	Off	On	On	On
40	Off	Off	On	Off	On	Off	Off	Off
41	Off	Off	On	Off	On	Off	Off	On
42	Off	Off	On	Off	On	Off	On	Off
43	Off	Off	On	Off	On	Off	On	On
44	Off	Off	On	Off	On	On	Off	Off
45	Off	Off	On	Off	On	On	Off	On
46	Off	Off	On	Off	On	On	On	Off

*Reserved

Table 2.A Switch settings for Node Address (U3) cont.

ControlNet Address	Switch positions							
	1	2	3	4	5	6	7	8
47	Off	Off	On	Off	On	On	On	On
48	Off	Off	On	On	Off	Off	Off	Off
49	Off	Off	On	On	Off	Off	Off	On
50	Off	Off	On	On	Off	Off	On	Off
51	Off	Off	On	On	Off	Off	On	On
52	Off	Off	On	On	Off	On	Off	Off
53	Off	Off	On	On	Off	On	Off	On
54	Off	Off	On	On	Off	On	On	Off
55	Off	Off	On	On	Off	On	On	On
56	Off	Off	On	On	On	Off	Off	Off
57	Off	Off	On	On	On	Off	Off	On
58	Off	Off	On	On	On	Off	On	Off
59	Off	Off	On	On	On	Off	On	On
60	Off	Off	On	On	On	On	Off	Off
61	Off	Off	On	On	On	On	Off	On
62	Off	Off	On	On	On	On	On	Off
63	Off	Off	On	On	On	Off	On	On
64	Off	On	Off	Off	Off	On	Off	Off
65	Off	On	Off	Off	Off	Off	Off	On
66	Off	On	Off	Off	Off	Off	On	Off
67	Off	On	Off	Off	Off	Off	On	On
68	Off	On	Off	Off	Off	On	Off	Off
69	Off	On	Off	Off	Off	On	Off	On
70	Off	On	Off	Off	Off	On	On	Off
71	Off	On	Off	Off	Off	On	On	On
72	Off	On	Off	Off	On	Off	Off	Off
73	Off	On	Off	Off	On	Off	Off	On
74	Off	On	Off	Off	On	Off	On	Off
75	Off	On	Off	Off	On	Off	On	On
76	Off	On	Off	Off	On	On	Off	Off
77	Off	On	Off	Off	On	On	Off	On
78	Off	On	Off	Off	On	On	On	Off
79	Off	On	Off	Off	On	On	On	On
80	Off	On	Off	On	Off	Off	Off	Off
81	Off	On	Off	On	Off	Off	Off	On
82	Off	On	Off	On	Off	Off	On	Off
83	Off	On	Off	On	Off	Off	On	On
84	Off	On	Off	On	Off	On	Off	Off
85	Off	On	Off	On	Off	On	Off	On
86	Off	On	Off	On	Off	On	On	Off
87	Off	On	Off	On	Off	On	On	On
88	Off	On	Off	On	On	Off	Off	Off
89	Off	On	Off	On	On	Off	Off	On
90	Off	On	Off	On	On	Off	On	Off
91	Off	On	Off	On	On	Off	On	On
92	Off	On	Off	On	On	On	Off	Off
93	Off	On	Off	On	On	On	Off	On
94	Off	On	Off	On	On	On	On	Off
95	Off	On	Off	On	On	On	On	On
96	Off	On	On	Off	Off	Off	Off	Off
97	Off	On	On	Off	Off	Off	Off	On
98	Off	On	On	Off	Off	Off	On	Off
99	Off	On	On	Off	Off	Off	On	On

Setting Up the Analog I/O

Before you can transfer data between the ControlNet Adapter Board and the analog I/O, you need to do the following:

1. Hard wire the analog I/O to the CNA Board terminals.
2. Set up the analog input and output configuration parameters in the drive.
3. Create any user links, if appropriate.



Note: The ControlNet Adapter Board has been pre-configured for your convenience. The pre-configured links are listed later in Figure 2.4.

Each terminal has parameters associated with it as shown here in the analog I/O block diagram.

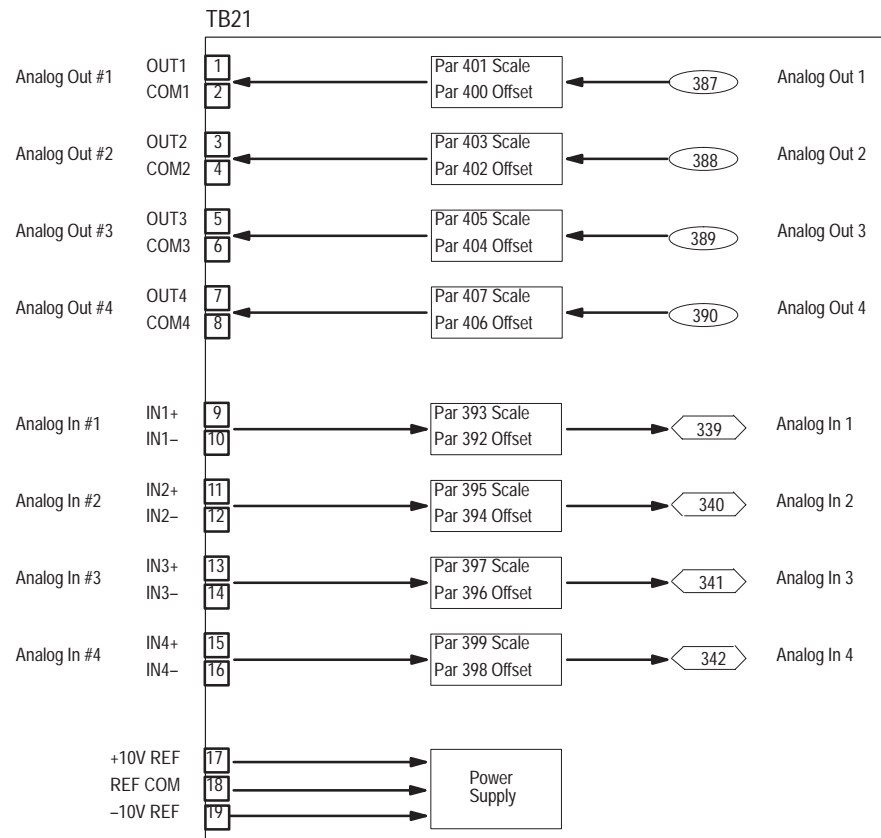

efesotomasyon.com

Use the set up parameters to program the ControlNet Adapter Board functions. The following parameters are used for set up:

Parameter number:	Parameter name:	These parameters determine the:
392, 394, 396, 398	Analog Input Offset	Offset applied to the raw Analog Input values before the scale factor is applied.
393, 395, 397, 399	Analog Input Scale	Scale factor or gain for Analog Input values.
400, 402, 404, 406	Analog Output Offset	Offset applied to the Analog Output values after the scale factor is applied.
401, 403, 405, 407	Analog Output Scale	Scale factor or gain for Analog Input values.

Configuration parameters allow the ControlNet Adapter Board to communicate with the drive. You need to link the configuration parameters to parameters in the drive. The following are the analog input and output configuration parameters:

Parameter number:	Parameter name:	These parameters are the:
339 – 342	Analog Input	Source parameters that are the result of converting a +10V signal to a +32767 value using the associated scale and offset parameters.
387 – 390	Analog Output	Sink parameters used to convert +32767 values to a +10V signal.

Each analog input and output is associated with a scaling and offset set up parameter. You must adjust these parameters for each analog device.

The drive works with internal drive units. Each parameter is a 16-bit word that allows a range of ± 32767 internal units. The drive is scaled so that 4096 is equal to one unit or 100% of the quantity being regulated. A $\pm 10V$ DC signal applied to an analog input is converted to a digital value of ± 2048 , providing a total range of 4096. When calibrating analog inputs, a scale factor is applied to this value to provide an effective range of ± 32767 (16×2048). The offset parameter determines the offset in volts, applied to the raw analog value before the scale factor is applied. This allows you to shift the range of the analog input by ± 4096 drive units (± 20 volts).

Understanding the Scale and Offset Parameters for Input

Analog Input 1 and Analog Input 2 are used in explaining the scale and offset parameters. At Analog Input 1, between TB21 terminals 9 and 10, a potentiometer with a range of $\pm 10\text{V}$ DC has been connected. Analog Input 1 has been linked to Velocity Reference (parameter 101) in the drive, which gives the potentiometer control of the external velocity reference.

To calibrate the pot to control 100% base speed in both directions, you need to adjust the scale parameter. The default value of the scale parameters allows a total range of 4096, -2048 to $+2048$. This allows only 50% base speed in each direction. By setting a scale factor of 2 in Analog Input 1 Scale, the digital input is multiplied by 2. This provides a range of ± 4096 , or 100% base speed in both directions.

If you want a range of ± 2 times base speed, the scale factor would be 4 (base speed is 4096, 2 times base speed is 8192, 2048 times 4 is 8192). Analog Input 1 Offset remains at the default value of zero, allowing the input range to be $\pm 10\text{V}$. The range of the offset parameter is $\pm 20\text{V}$ DC as shown in Figure 2.1.

Figure 2.1
Potentiometer with +10V Range to Control 0 to +100% Base Speed

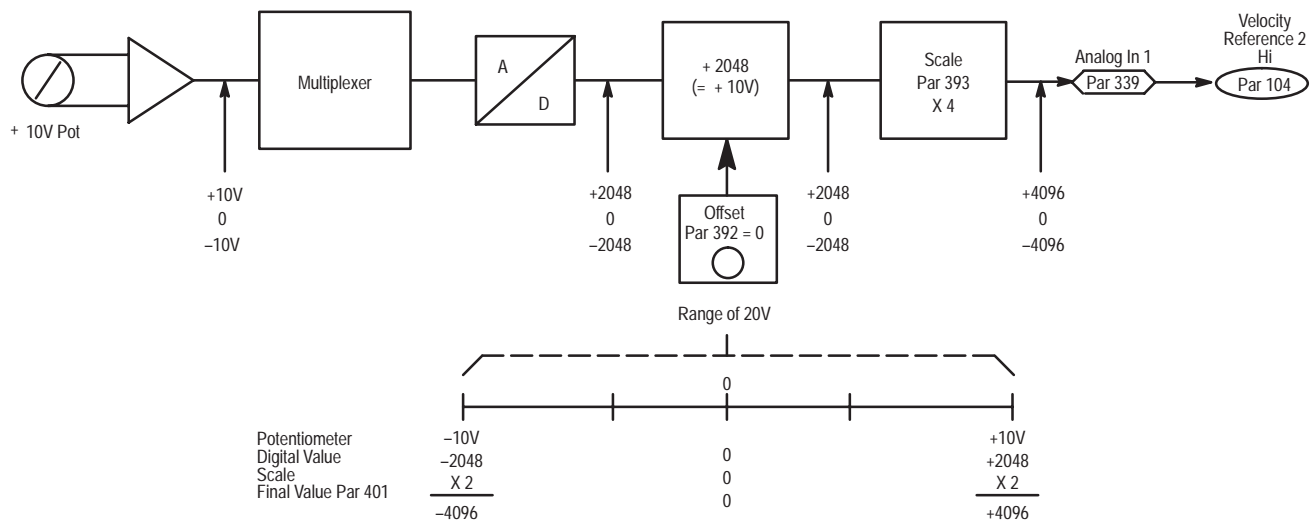

For Analog Input 2, a 0 to 10 volt potentiometer is used to adjust the Torque Reference from -100% to $+100\%$. To do this, you need to adjust both the scale and offset parameters. By linking Analog Input 2 to Torque Reference (parameter 162), the potentiometer connected to Analog Input 2 becomes the Torque Reference Signal. This signal must be scaled and offset to get the entire $\pm 100\%$ in the 0 through 10 volt range. A digital range of 8192 (± 4096) must now be scaled for an analog range of 10 volts, and must be offset so 5 volts on the potentiometer indicates 0% Torque.

As shown in Figure 2.2, the offset voltage adds the corresponding digital value to the range. In this case, an offset of -5 volts adds a digital value of -1024 to the range. This causes 0 volts on the potentiometer to register as -1024 digital internal to the drive and 10 volts on the potentiometer will be $+1024$ to the drive. This can then be scaled by a factor of 4 (8192 drive units) so that 0 volts sends a digital value of -4096 for -100% torque, and 10 volts sends a digital value of $+4096$ for $+100\%$ torque.

Figure 2.2
Potentiometer 0–10V Range to Control +100% Torque Reference

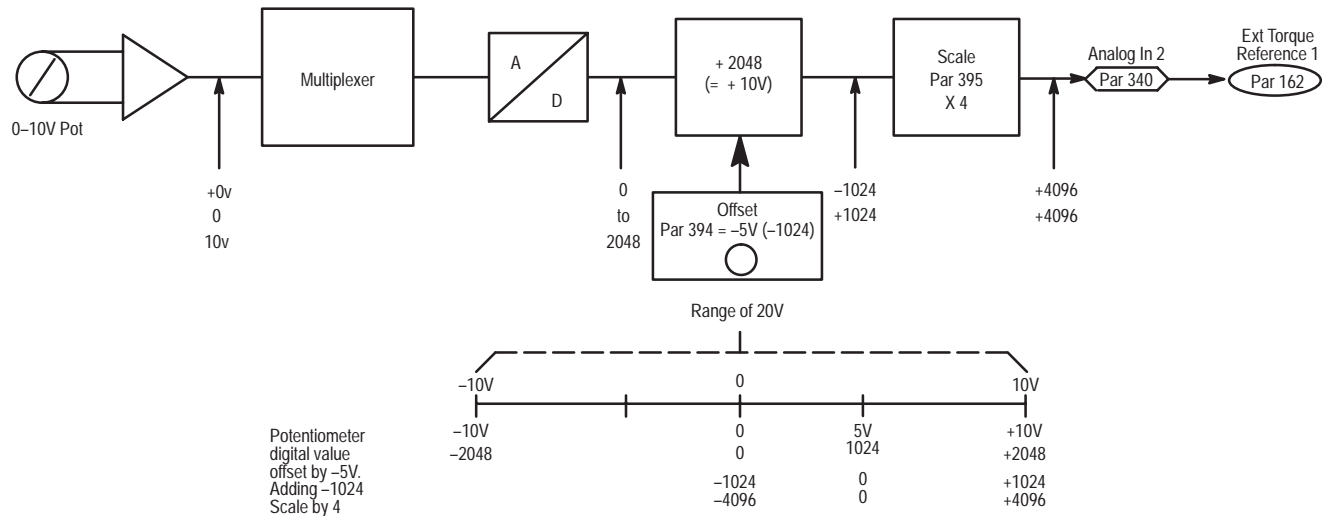

Understanding the Scale and Offset Parameters for Output

Analog outputs are similar to analog inputs. Each output has a scale and offset parameter, along with a specific variable parameter used for linking. Differences occur because of the direction of information flow. The drive sends a digital value in drive units, which must be matched to the voltage of the monitoring device. Similar to analog inputs, the analog output converts a ± 2048 value to $\pm 10V$ DC. Thus, when the drive sends $\pm 100\%$ base speed (equal to ± 4096), it must be scaled by 0.5 to be in the proper range ($\pm 4096 \times 0.5 = \pm 2048$). The offset can be $\pm 20V$ DC, even though the physical limit is $\pm 10V$ dc. This allows you to offset the signal anywhere within the entire range.

In Figure 2.3, Analog Output 1 is used as an example to show the scale and offset parameters. At Analog Output 1, a meter with a range of 0 through $10V$ DC has been connected. Analog Output 1 has been linked to Velocity Feedback (parameter 269).

For the meter to indicate speed in both directions, you need to adjust the scale and offset parameters as shown in Figure 2.3. Working in the opposite direction as the analog inputs, apply the scale factor first. The drive sends a ± 4096 digital value to indicate $\pm 100\%$ velocity feedback for a total digital range of 8192. The meter, having an analog range of 0 through 10V DC, requires a digital range of 2048. This is done by applying a scale factor of 0.25 ($8192 \times 0.25 = 2048$).

To have the 0 through 10V DC meter indicate $\pm 100\%$ feedback, you need to apply an offset. Offset parameters for analog outputs will again add the corresponding digital value to the range. In this case, an offset of 5 volts adds a digital value of 1024 to the range. This allows full range deflection on the 0 to 10 volt meter, with 5 volts indicating zero speed.

Figure 2.3
Analog Output 1 +100% Speed Indication

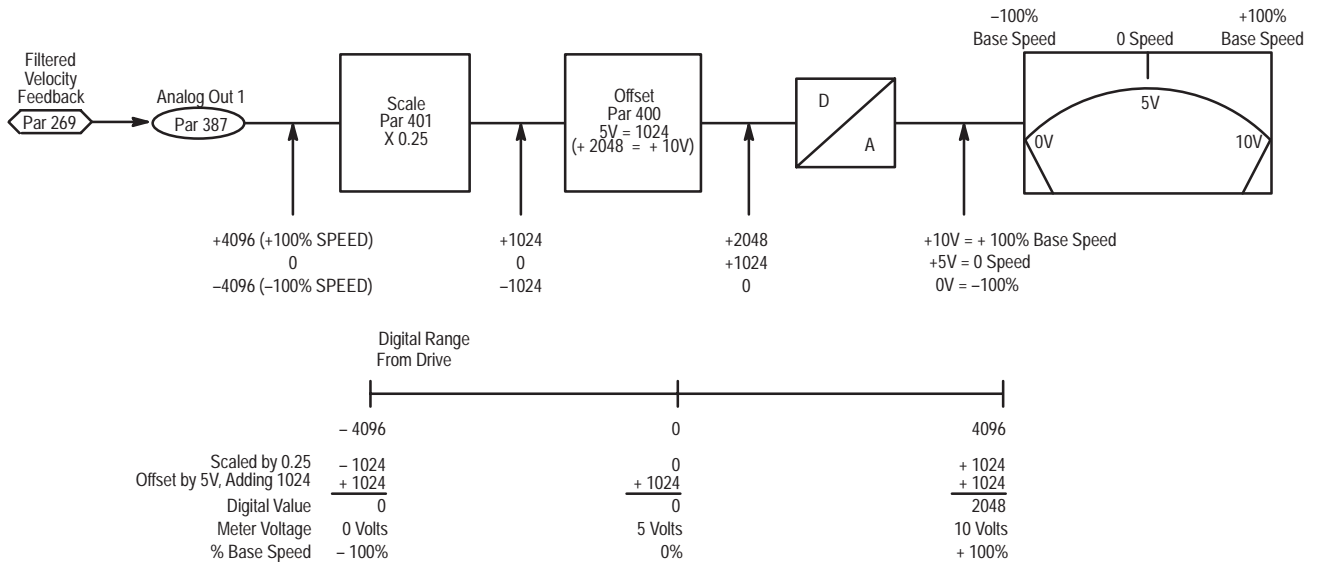

Using the SCANport Capabilities

To communicate with external devices such as terminals, the ControlNet Adapter Board uses the SCANport communications protocol. You can access the SCANport capabilities without doing any special configuration. However, if you plan to use SCANport, you can make some changes to the default configuration to customize the way SCANport works for you. Chapter 5, *Understanding the Resources of Your Drive*, contains information about SCANport and how you can change the default configuration.

Pre-Configured Links

The ControlNet Adapter Board is shipped pre-configured. Some of the inputs and outputs to the board are linked to a pre-defined signal. Figure 2.4 shows the 1336 FORCE standard configuration for the ControlNet Adapter Board. You can change this and re-configure the drive on a per-application basis.



Note: When a link is set up, the data is transferred from the configured source to a sink every millisecond.

Figure 2.4
ControlNet Adapter Board Configuration Example--Factory Default Links:

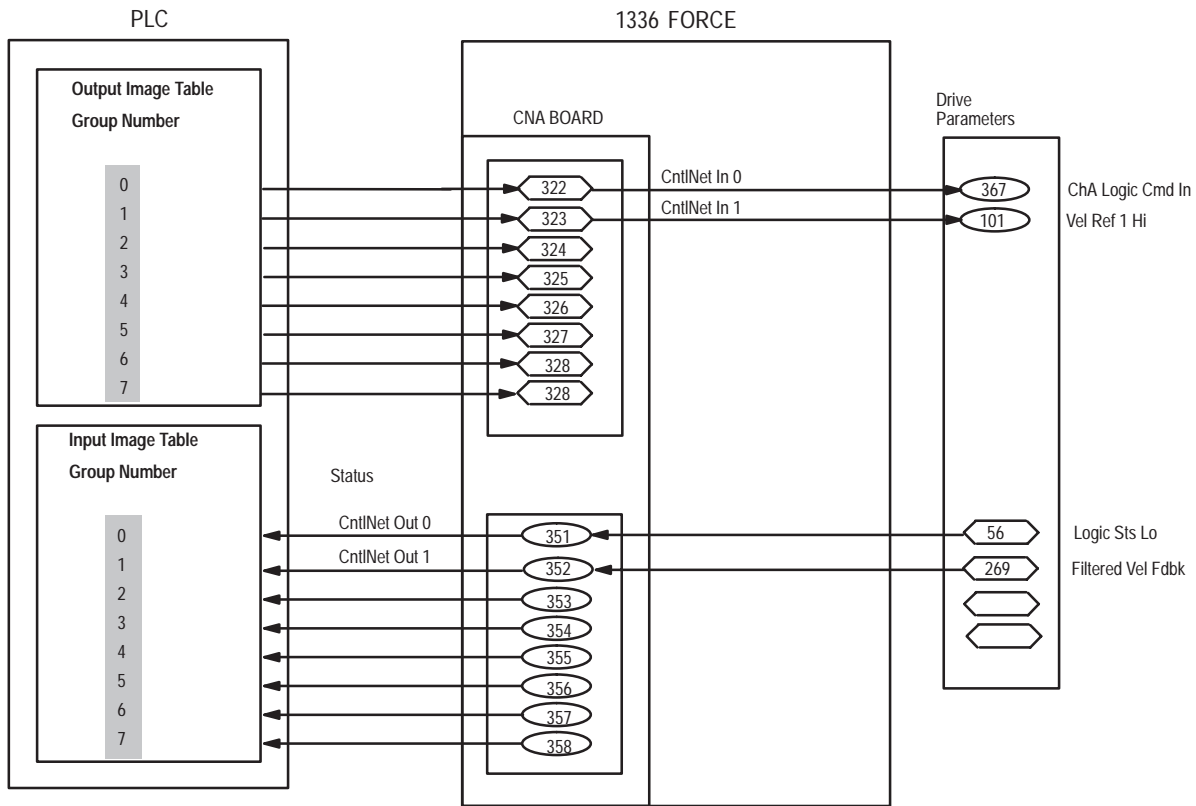

Using Scheduled Discrete Data Transfer

Chapter Objectives

This chapter provides information that can help you understand and use ControlNet communications. This chapter covers the following topics:

- understanding communications
- transferring data using scheduled discrete data transfer

Understanding ControlNet Communications

When you use the ControlNet Adapter Board for ControlNet communications, the drive looks like a remote I/O chassis to a PLC. This allows you to use discrete message transfer.

With discrete message transfer, the PLC's I/O image table is used to transfer the data that the drive needs to have continuously updated.

ATTENTION: When configuring this drive on a ControlNet network, you must request a NUT (Network Update Time) of 5ms or greater. A NUT less than 5ms may cause data transfers to (and from) the drive to become non-deterministic.

ControlNet has the option for redundancy. Redundancy for the entire network is determined by the configuration tool (RS Networx™).

Transferring Data Using Discrete Data Transfer

The drive requires that some data be continuously updated. This data is transferred using the PLC's I/O image table. This data is transferred between the drive and the PLC every Network Update Interval (NUI).

Each group number reserves a single 16-bit word in both the input and output image table of the PLC for the assigned rack number. In the drive, these words are directly linked to internal drive parameters using source and sink parameters.



In the following descriptions, each module group appears to have a 16-bit input and output module installed.

The following figure shows the ControlNet full rack configuration.

Module Group

0	1	2	3	4	5	6	7
---	---	---	---	---	---	---	---

The following figure shows an example of the ControlNet Adapter Board communications. Notice that you can use the first module group number.

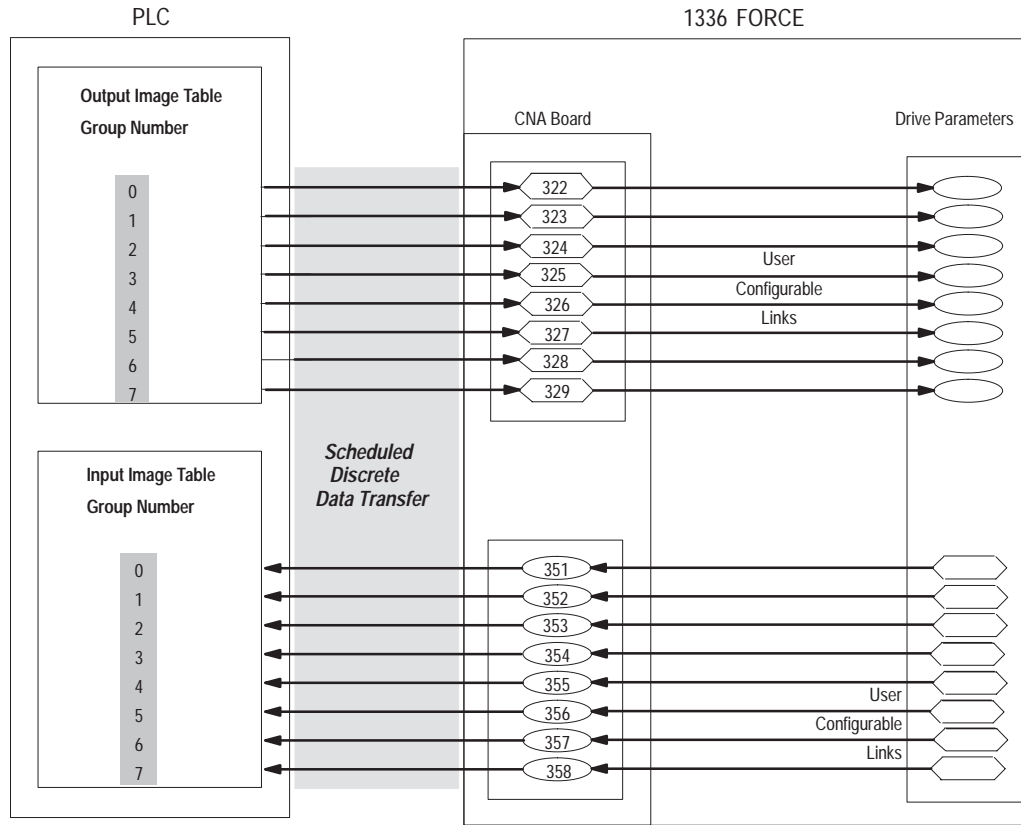

Discrete PLC Programming

The following figure shows an application where the ControlNet Adapter Board has been set up for rack 2 and the PLC program is using the 16-bit words for groups 0 and 1 for data transfer with the 1336 FORCE. You should refer to this figure to help understand the following description.

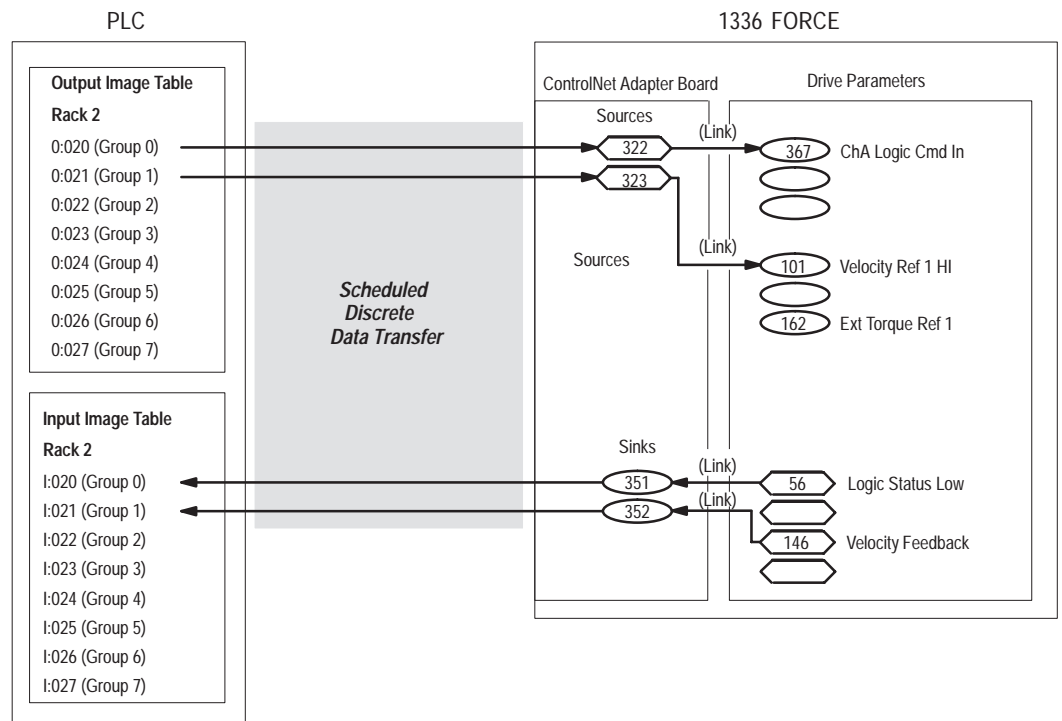

In this example, the drive has been configured so that the data coming into source parameter 322 is linked to parameter 367, ChA Logic Cmd In. Information linked to the 1336 FORCE using the 16-bit output word for group 0 of rack 2 must be a 16-bit word where the bits are defined by the description of parameter 367.

Parameter 101, Velocity Ref 1 HI, has been linked to source parameter 323. The 16-bit output word for group 1 of rack 2 must be a 16-bit signed integer whose value is within the allowable range of values in drive units for parameter 101.

Information from the 1336 FORCE consists of parameter 56, Logic Status LOW, and parameter 146, Velocity Feedback. Based on the links shown, the 16-bit input word for group 0, rack 2 in the PLC controller is a 16-bit logic status word. The description for parameter 56 defines the bits in this 16-bit word. In addition, the 16-bit input for group 1, rack 2 in the PLC is a 16-bit signed integer whose value corresponds to the allowable values in drive units for parameter 146.

Scaling

If the PLC is to manipulate the data transferred between the 1336 FORCE and the PLC in units other than drive units, the data must be appropriately scaled when it is transferred to a drive parameter. You can do the scaling either at the PLC or by using drive function blocks. The scaled information must be based on drive unit definitions for parameters in the 1336 FORCE.

Parameter 101, Velocity Reference 1 HI, shown in the previous figure, is in drive units, where 4096 is defined as base speed. If the PLC controller program is written in terms of feet-per-minute (fpm), then you need to convert fpm to drive units before sending it to parameter 101.

Discrete I/O Program Example

A PLC controller program is shown on the next page. You could use this example to control the 1336 FORCE. Based on the configuration shown in the previous figure, the PLC program transfers information to parameters 367 and 101 in the 1336 FORCE. Logic bits in File B3 of the PLC are used to set the drive logic control bits, and integer file N10 word 01 is used to store the drive speed reference.

To control the logic operation of the drive, the PLC program must control the bits in the output image table that correspond to the desired operation. Because parameter 322 in the previous figure has been linked to parameter 367 and parameter 322 is associated with group 0 in the output image table, the PLC program is controlling bits in word 0:20.

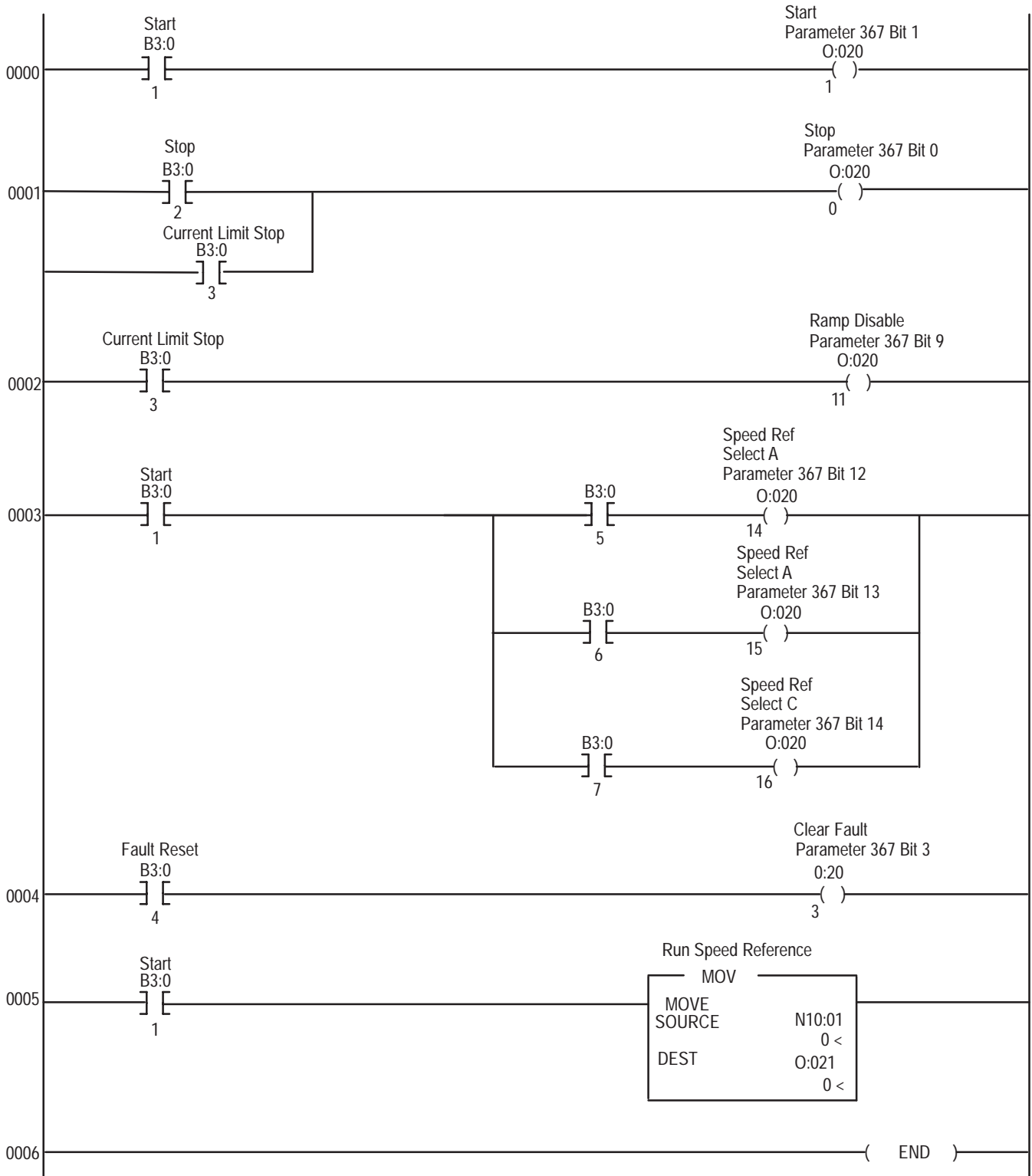

In this example, word 1 of integer file N10 stores the speed reference for the drive. The MOV block in rung 6 of the example PLC program transfers the 16 bit word N10:01 to word 2 of the output image table. Because word 2 of the output image table is sent to parameter 324, which in turn is linked to parameter 101, the 16-bit word N10:01 is the speed reference input to drive parameter 101.

Information transferred back to the PLC from the drive is handled much as it was in the previous example, with the exception that data is transferred into the input image table of the PLC. Again, note that bit coded words such as parameter 56, Logic Status LOW, are bit numbered in octal in the PLC, while the drive is in decimal.

Using Unscheduled Messaging

Chapter Objectives

Chapter 4 provides the following information:

- ControlNet features
- Emulated block transfer message structures
- ControlNet command set
- Emulated Block Transfer Message Structures

ControlNet Features

You can configure either one or both channels for ControlNet communications. Configuration as a ControlNet device allows the drive to look like a station on the ControlNet link. ControlNet features include:

- 5 megabit baud rate
- Parameter read and write messages for a block of parameters

Message Instruction

The message instruction is used to read and write a block of data to another station on the ControlNet link. The following is a description of the message instruction field data. Refer to the example program at the end of this chapter for a message instruction example.

This function:	Specifies:
Communication Command	Whether the MSG instruction performs a PLC5 TYPED READ to read data from the drive or a PLC 5 TYPED WRITE to write data to the drive.
PLC5 Data Table Address	The data file address where data is stored. <ul style="list-style-type: none"> •If the MSG operation is a write, this address is the starting word of the source file for data sent to the PLC Communications Adapter Board. •If the MSG operation is a read, this address is the starting word of the destination file for data returned from the PLC Communications Adapter Board.
Size In Elements	The number of elements to be transferred. Note that: <ul style="list-style-type: none"> •For a Read Parameter function, each element is one word. Therefore, when reading 10 parameter values, the field needs to be a length of 10 elements. •For a Read Parameter Full, each element is 20 words long. Therefore, a Read Full function of 6 parameters requires an entry of 120 elements. •For N40, the size must be 64 words.
Local/Remote	Local indicates the message is sent to a device on the local CN link. For this application, this field is always local.
Local Node Address	The local station address on the CN link. This is defined through the DIP switch (U3) on the PLC Communications Adapter Board.
Destination Data Table Address	The starting address represents the type of service requested at the PLC Communications Adapter Board destination file. Refer to the CN Command Set section for more information.

ControlNet Command Set

The specific memory area emulated by the drive determines the specific request or action to be taken by the CNA board. These memory areas resemble PLC addresses.

The following commands are supported:

Command:	Description:
WHO ACTIVE	The station number of the ControlNet Adapter Board as defined by its DIP switch settings is displayed on the WHO ACTIVE screen of the PLC software. It will read DRIV0 1336T next to the selected station number.
PLC 5 TYPED READ (N10:1-493)	Memory area N10:1-493 translates into a read parameter value from the 1336 FORCE. Any attempt to read outside of this range results in an error response. The 1336 FORCE interprets the values 1 through 493 as parameter numbers. For example, to read the value of parameter 133, the MSG instruction would request N10:133 with a size of one element. A size of 10 would read parameters 133 through 142.
PLC 5 TYPED WRITE (N10:1-493)	Memory area N10:1-493 translates into one or more write parameter values to the 1336 FORCE. If you try to write outside of this range, you will get an error. The 1336 FORCE interprets the values 1 through 493 as parameter numbers. For example, to write a value to parameter 119 (Preset Speed 1), the MSG instruction would specify N10:119 with a size of one element. A size of 10 will write to parameters 119 through 128.
PLC TYPED READ (N20:0-493)	This request reads the status of the previous parameter writes (N10:1-493). If a TYPED READ is specified with a PLC address of N20:0, the write status of all parameters from the last TYPED WRITE request (N10:X-XXX) are OR'ed together. If one error has occurred during the last write operation, this address contains the parameter number where the error occurred. If multiple errors occurred, the value is -1, and the PLC controller can request a TYPED READ of N20:1-493 to determine which parameters have had errors.

Command:	Description:
PLC TYPED READ (N30:0-493)	This request translates into a read parameter full message in the 1336 FORCE. Each parameter specified results in 20 words of data (actual value, minimum value, maximum value, descriptor, and parameter text). You can read a maximum of 50 parameters with this service if your PLC uses a file size of 1000 words. If your PLC uses a different file size, this service may take a different number of parameters.
PLC 5 TYPED READ (N40:0-63)	This message emulates the block transfer functions with the exception of the multiple parameter read. Refer to the emulated message structure section later in this chapter, for details on the available messages and their use.
PLC 5 TYPED WRITE (N40:0-63)	This message emulates the block transfer functions. Refer to the emulated message structure section in later in this chapter for details on the available messages and their use.
PLC 5 TYPED READ (N50:0-499) for Trend 1 (N51:0-499) for Trend 2 (N52:0-499) for Trend 3 (N53:0-499) for Trend 4	This message reads real time trend sample data. Refer to the emulated message structure section in later in this chapter for details on the available messages and their use.
PLC 5 TYPED READ (N70:0-499) for Trend 1 (N71:0-499) for Trend 2 (N72:0-499) for Trend 3 (N73:0-499) for Trend 4	This message reads the trend sampled data, which is the data retained when a trigger condition occurs. A file of 70 corresponds to trend 1, 71 to trend 2, 72 to trend 3, and 73 to trend 4.

The following examples show two rungs from a sample program for a PLC 5/40C15.

Example 1

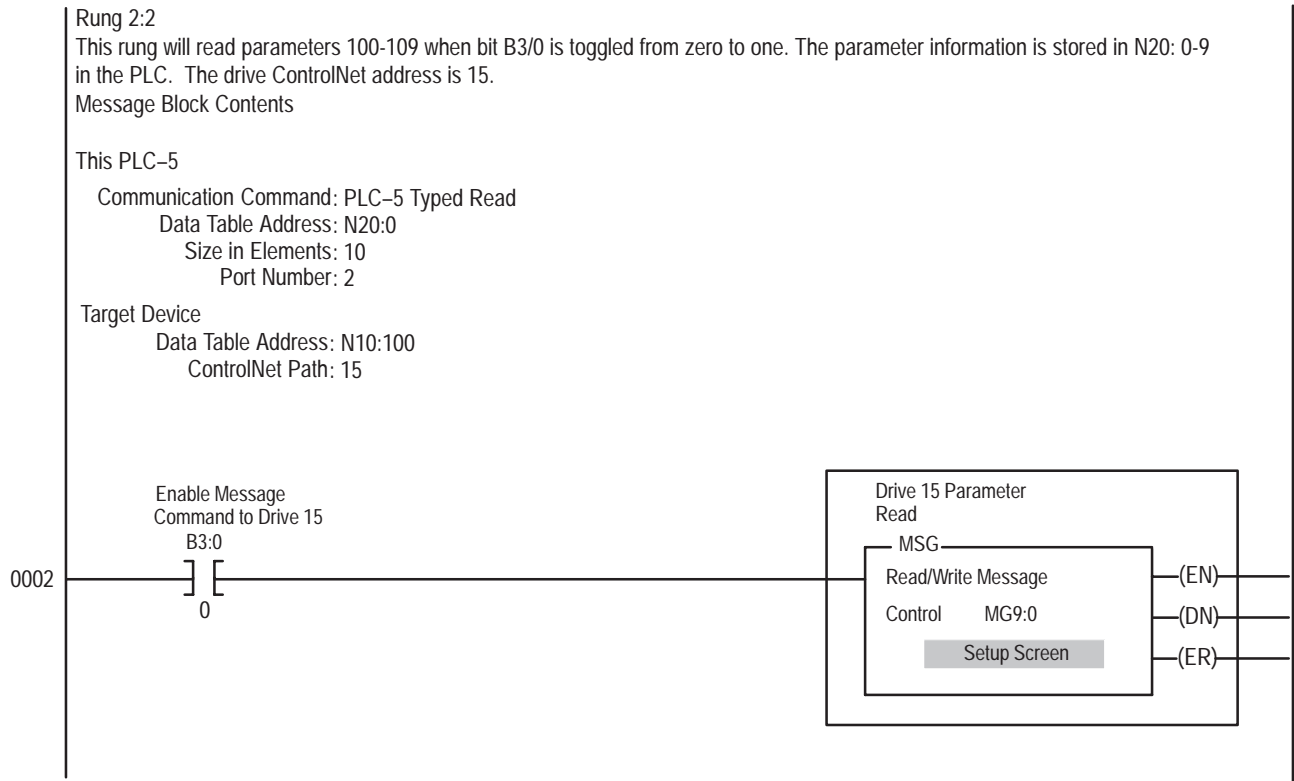

MSG MG9:0

This PLC-5
 Communication Command:
 Data Table Address:
 Size in Elements:
 Port Number:

Target Device
 Data Table Address:
 ControlNet Path:

Control Bits
 Ignore if timed out (TO):
 To be retired(NR):
 Awaiting Execution(EW):
 Continuous Run(EW):
 Error(ER):
 Message done(DN):
 Message enabled(EN):

Enable
 Error Code (Hex): 0

EXAMPLE 2

Rung 2:2

This rung will read parameters 100-109 on a continuous basis by using the Message Block enable bit to toggle the next message.
 The parameter information is stored in N20:0-9 in the PLC.
 The drive ControlNet address is 15.

Message Block Contents

This PLC-5

Communication Command: PLC-5 Typed Read
 Data Table Address: N20:0
 Size in Elements: 10
 Port Number: 2

Target Device

Data Table Address : N10:100
 ControlNet Path : 15



MSG MG9:1

<p>This PLC-5</p> <p>Communication Command: <input type="text" value="PLC-5 Typed Read"/></p> <p>Data Table Address: <input type="text" value="N20:0"/></p> <p>Size in Elements: <input type="text" value="10"/></p> <p>Port Number: <input type="text" value="2"/></p>		<p>Control Bits</p> <p>Ignore if timed out (TO): <input type="checkbox" value="0"/></p> <p>To be retired(NR): <input type="checkbox" value="0"/></p> <p>Awaiting Execution(EW): <input type="checkbox" value="0"/></p> <p>Continuous Run(EW): <input type="checkbox" value="0"/></p> <p>Error(ER): <input type="checkbox" value="0"/></p> <p>Message done(DN): <input type="checkbox" value="0"/></p> <p>Message enabled(EN): <input type="checkbox" value="0"/></p>
<p>Target Device</p> <p>Data Table Address: <input type="text" value="N10:100"/></p> <p>ControlNet Path: <input type="text" value="15"/></p>		
<p>Enable</p> <p>Error Code (Hex): 0</p>		

Emulated Block Transfer

PLCs use discrete transfer to transfer data to and from the ControlNet Adapter Board during every rack scan. The ControlNet Adapter Board transfers this data to and from the SCANport device.

The PLC's use message blocks to perform emulated block transfer.

The descriptions provided in this chapter contain the configurations necessary to set up the data files in the message transfer instructions. Header and data values depend on the operation to be performed. Also included is a description of the status word that is returned from the drive and appears in the message transfer read header information.

Message Summary

The following table summarizes the valid command code that is displayed in word 2 of the message transfer write header message. A complete description of the message transfer write header message is provided on the specified page.

Class:	Function:	PLC Decimal Value:	Page:
Parameter Read	Parameter Value Read	769	4-9
	Continuous Parameter Value Read	1	4-11
	Scattered Parameter Value Read	3	4-13
	Parameter Read Full	768	4-15
Parameter Write	Parameter Value Write	-31999	4-18
	Continuous Parameter Value Write	-32767	4-19
	Scattered Parameter Value Write	-32765	4-21
Fault Queue	Fault Clear/Reset	-30976	4-23
	Trip Fault Queue Number	1793	4-25
	Fault Entry Read Full	1792	4-26
Warning Queue	Warning Clear	-30720	4-28
	Warning Queue Read Full	2048	4-30
EE Memory Request	Save/Recall/Initialize	-31988	4-32
Link Read	Link Parameter Read	2304	4-34
	Continuous Parameter Link Read	4	4-35
	Scattered Parameter Link Read	5	4-37
Link Write	Link Parameter Write	-30464	4-39
	Continuous Parameter Link Write	-32764	4-40
	Scattered Parameter Link Write	-32763	4-42
	Parameter Link Clear	-30464	4-44
User Text String	User Text String Read	261	4-45
	User Text String Write	-32507	4-47
Clock Data	Real Time Clock Data Read	2816	4-49
	Real Time Clock Data Write	2816	4-51
Run Time Accumulator	Run Time Accumulator Data Read	2817	4-53
	Clear Run Time Accumulator	-29950	4-55
Time Stamp	Reference Time Stamp Data Read	2816	4-56
	Reference Time Stamp Data Write	-29952	4-58
	Load Clock Info Reference Stamp	0	4-60
Trend File	Number of Trends Available	4096	4-61
	Maximum Trend Size Available	4097	4-62
	Trend Command	-28672	4-63
	Trend Status	4097	4-65
	Setup Data Full	-28670	4-67
	All Info	4098	4-70
	Trigger Time	4099	4-73
	Run File Data	4100	4-75
	Stored File Data	4101	4-78
	Trend Parameter Definition	4102	4-80
	Trend Triggered Setup Parameter Values	4103	4-82

Parameter Read

Parameter Value Read

This message is sent by the ControlNet Adapter Board and reads the 16-bit parameter data value for the parameter number selected.

PLC Block Transfer Instruction Data

PLC MSG Write instruction length: 3 words
 PLC MSG Read instruction length: 4 words

Message Structure

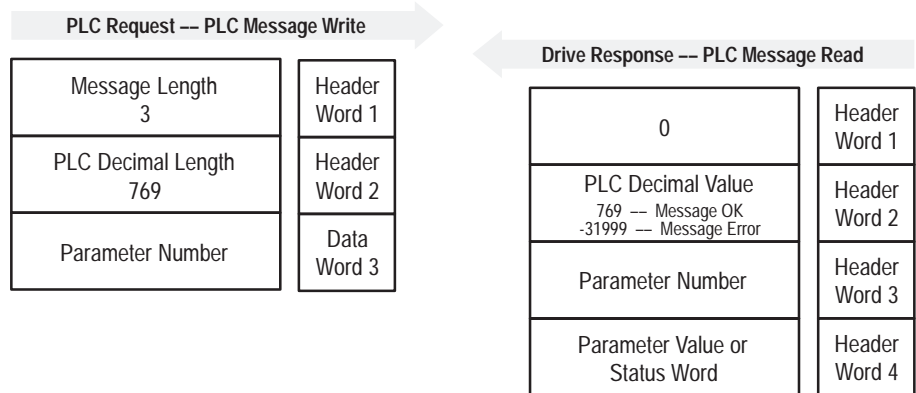

Message Operation

The Parameter Value Read function specified in the PMW (PLC MSG Write) reads a parameter value from the drive and places that value (or an error code) in word 4 of the PMR (PLC MSG Read) data file. The value shown is in device units.

If an error has occurred:

- Word 2 of the PMR returns a value of -31999.
- Word 4 contains the status code.

Parameter Value Read
(continued)

Example

In this example, the value of parameter 20 was requested from a 1336 FORCE and a value of 4096 was returned. 4096 is the internal drive unit value for the Maximum Rated Voltage Parameter. This corresponds to a value of 100% drive rated volts in display units.

Data Format

		0	1	2	3	4	5	6	7	8	9
PLC MSG Write File	N7:10	3	769	① 20							
PLC MSG Read File	N7:90	0	769	① 20	① 4096						

① These values vary depending on parameters and products.

Parameter Read

Continuous Parameter Value Read

The Continuous Parameter Value Read function reads a continuous list of parameters beginning with the starting parameter number. You define the number of parameters to be read.

PLC Block Transfer Instruction Data

PLC MSG Write instruction length: 4 words
 PLC MSG Read instruction length: 5-64 words

Message Structure

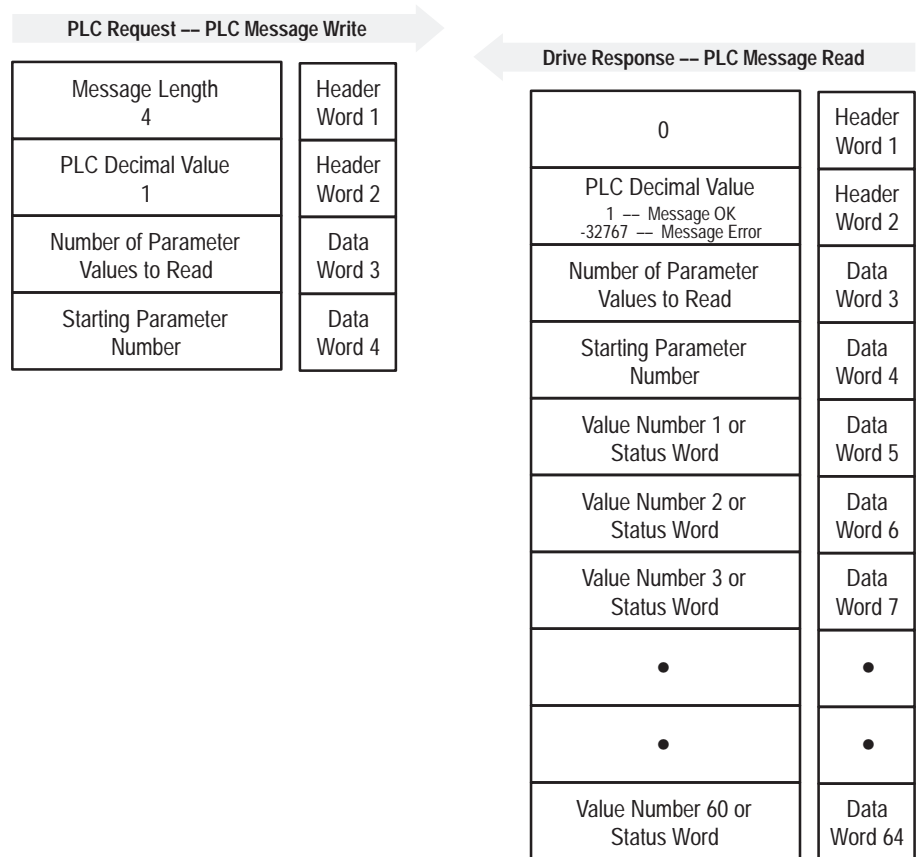

Message Operation

The Continuous Parameter Value Read function specified in the PMW reads a consecutive group of parameter values from the device, beginning with the starting parameter number defined in word 4 of the PMW message. Word 3 of the PMW message defines the number of parameters to be read. The values return in the PMR response, beginning with word 5 of the message.

If an error has occurred in reading any of the values, the PMR returns a status word with a negative value instead of the parameter value.

Continuous Parameter Value
Read
(continued)

Example

In this example, 60 parameters were read from a 1336 FORCE, beginning with parameter 10. The values of these parameters are returned in the PMR data file, beginning at N7:94. The values are in drive units.

Data Format		0	1	2	3	4	5	6	7	8	9
PLC MSG Write File	N7:10	4	1	① 60	① 10						
PLC MSG Read File	N7:90	0	1	① 60	① 10	① 0	① 0	① 0	① 0	① 0	① 100
	N7:100	① 0	① 50	① 4096	① 60	① 4096	① 1	① 6	① 0	① 1000	① 0
	N7:110	① 0	① 0	① 0	① 0	① 1000	① 1000	① 400	① 400	① 400	① 0
	N7:120	① 6144	① 2	① 4710	① 1	① 1	① 0	① 0	① 0	① 0	① 2
	N7:130	① 64	① 0	① 0	① 15	① 1024	① 0	① 0	① 5811	① 0	① 18
	N7:140	① 0	① 0	① 0	① 3597	① 0	① 12808	① 6	① 0	① 0	① 17952
	N7:150	① 0	① 0	① 0	① 0	① 0					

① These values vary depending on parameters and products.

Parameter Read

Scattered Parameter Value Read

The Scattered Parameter Value Read function reads a scattered list of parameters with each parameter you define. You must also define the number of parameters to be read.

PLC Block Transfer Instruction Data

PLC MSG Write instruction length: 5-63 words
 PLC MSG Read instruction length: 5-63 words

Message Structure

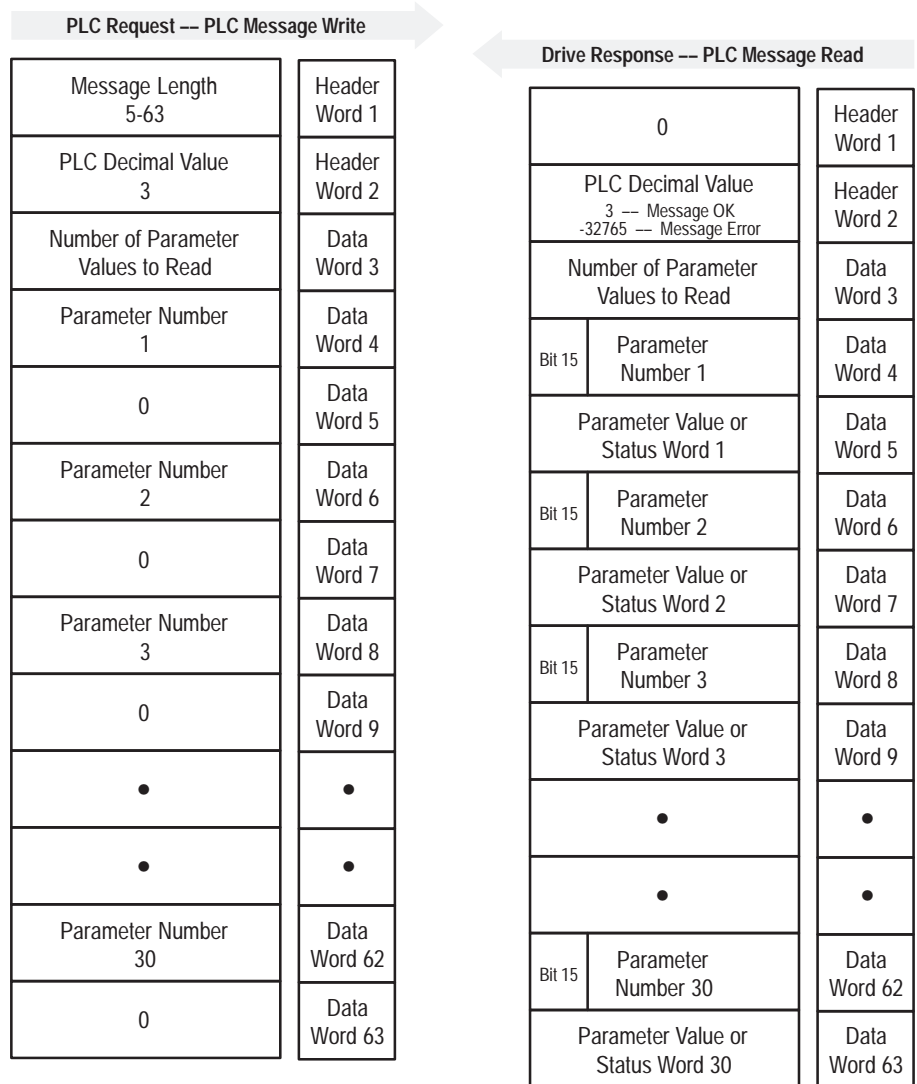

Scattered Parameter Value Read (continued)

Message Operation

The Scattered Parameter Value Read function specified in the PMW reads a pre-defined group of parameter values, in any order, from the device. Word 3 of the PMW data file defines the number of parameters to be read. The parameters to be read and their order is defined starting with word 4. An unused word is left between each parameter request, so the PMR can respond with the parameter value as shown.

If an error has occurred in reading any of the parameters:

- Word 2 of the PMR returns a value of -32765.
- Bit 15 of the PMR word for the number of that parameter is set.
- The PMR word for the value of that parameter returns a status word instead of the parameter value.

Example

In this example, eight parameters were read from a 1336 FORCE, as defined in word 3 of the PMW data file. The requested parameter numbers were 5, 7, 8, 20, 18, 17, 19, and 36. The PMR response returned the values of these parameters into the PMR data file. These values are in drive units.

Data Format		0	1	2	3	4	5	6	7	8	9
PLC MSG Write File	N7:10	19	3	① 8	① 5	0	① 7	0	① 8	0	① 20
	N7:20	0	① 18	① 0	① 17	0	① 19	0	① 36	0	
PLC MSG Read File	N7:90	0	3	① 8	① 5	① 6	① 7	① 1000	① 8	① 1000	① 20
	N7:100	① 4096	① 18	① 4096	① 17	① 51	① 19	① 60	① 36	① 6144	

① These values vary depending on parameters and products.

Parameter Read

Parameter Read Full

The Parameter Read Full function provides the requesting remote I/O source with all known attributes for the parameters requested. This information includes the parameter's current value; descriptor; multiply and divide value; base value; offset value; text string; file, group, and element reference; minimum value; maximum value; default value; and unit text string.

PLC Block Transfer Instruction Data

PLC MSG Write instruction length: 3 words
 PLC MSG Read instruction length: 23 words

Message Structure

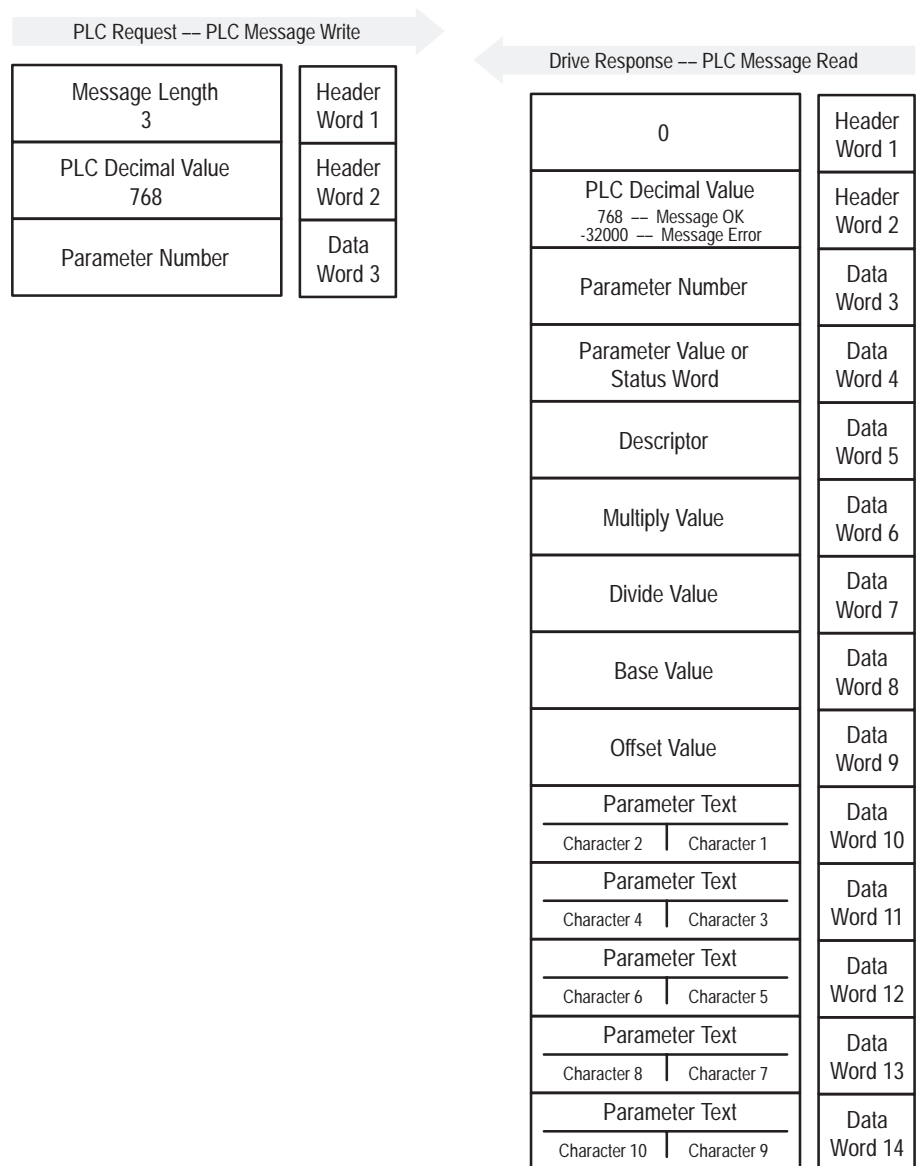

Parameter Read Full (continued)

← Drive Response -- PLC Message Read

Parameter Text Character 12 Character 11	Data Word 15
Parameter Text Character 14 Character 13	Data Word 16
Parameter Text Character 16 Character 15	Data Word 17
File, Group, Element	Data Word 18
Minimum Value	Data Word 19
Maximum Value	Data Word 20
Default Value	Data Word 21
Unit Text Character 2 Character 1	Data Word 22
Unit Text Character 4 Character 3	Data Word 23

Message Operation

The Parameter Read Full function specified in the PMW retrieves the attributes of the requested parameter. The attributes for each parameter include the data, minimum and maximum values, and the parameter text. The response message returns this information, beginning with data word 4. The parameter text is returned with each data word containing two ASCII characters per word. This data returns with the first and second characters in opposite order as shown in the following example.

If an error has occurred in the block transfer, word 2 of the PMR returns a value of -32000.

Example

In this example, a Parameter Read Full was performed through block transfer on a 1336 FORCE. N7:10 shows the header message for the PMW. The data is returned in the PMR data file, starting with word 4, for parameter 101. Word 4 shows the present value in drive units. Words 5 through 9 provide scaling information, used to convert drive units to engineering units. Words 10 through 17 provide the parameter name.

Parameter Read Full
(continued)

This example shows the response message N7:90 through N7:112 in both binary and ASCII. Note the ASCII information beginning with N7:99. The parameter name characters return in reverse order for each word. N7:99 has the ASCII value of *eV*. To read this, invert the word to read *Ve*. The next word (*space*)*l*, inverted gives you *l(space)*. These words, along with the following two words, form the word “Vel_” The parameter name *Vel ReflHi* can be seen in words 10 through 17 of the response message. In addition, word 23 is also returned in this format. This word provides the units the parameter is defined in, which in this example is “RPM”.

Word 18 contains the file, group, and element which are used to reference the parameter.

Words 19 through 21 contain the minimum, maximum, and default values of this parameter.

Data Format		0	1	2	3	4	5	6	7	8	9
PLC MSG Write File	N7:10	3	768	① 101							
PLC MSG Read File	N7:90	0	768	① 101	① 2801	① 4364	① 1755	① 4096	① 10	① 0	① 25942
	N7:100	① 8300	① 25938	① 8294	① 8241	① 26952	① 8224	① 8224	① 548	① -32767	① 32767
	N7:110	① 0	① 2562	① 8269							
	N7:90	\00\00	\05\00	\00\0E	\0A\F1	\11\0E	\06\03	\10\00	\00\0A	\00\00	eV
	N7:100	(sp)l	eR	1f	iH		\025	C\01	\7F\FF	04 00	\13 0
	N7:110	\00\00	PR	(sp)M							

ASCII Display Values

① These values vary depending on parameters and products.

Parameter Write Parameter Value Write

This message sent by the PLC Communications Adapter Board reads the 16-bit parameter data value for the parameter number selected.

PLC Block Transfer Instruction Data

PLC MSG Write instruction length: 4 words
 PLC MSG Read instruction length: 4 words

Message Structure

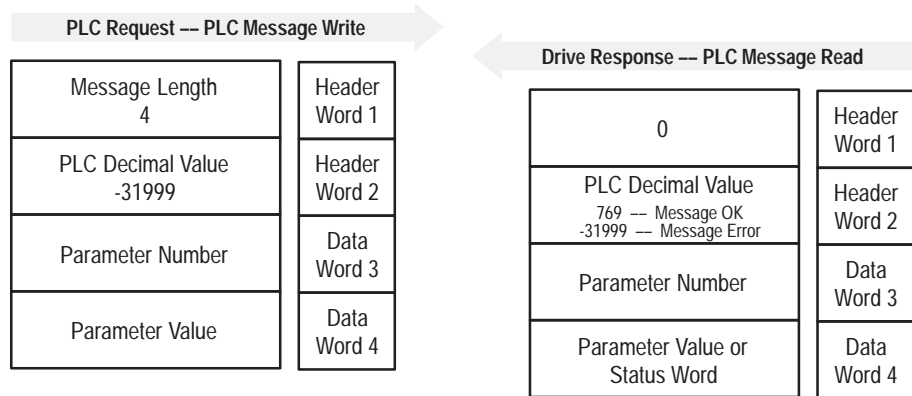

Message Operation

The Parameter Value Write function specified in the PMW sends a new value (specified in word 4 of the PMW header message) to the parameter specified in the PMW header word 3. The value must be in device units.

If an error has occurred:

- Word 2 of the response returns a value of -31999.
- Word 4 contains a status code.

Example

In this example, a value of 4096 was sent to parameter 20. 4096 is in drive units and indicates a value of 100% of rated drive volts as defined by parameter 147, Drive Rated Volts.

Data Format

		0	1	2	3	4	5	6	7	8	9
PLC MSG Write File	N7:10	4	-31999	① 20	① 4096						
PLC MSG Read File	N7:90	0	769	① 20	① 4096						

① These values vary depending on parameters and products.

Parameter Write

Continuous Parameter Value Write

The Continuous Parameter Value Write function writes to a continuous list of parameters beginning with the starting parameter number.

PLC Block Transfer Instruction Data

PLC MSG Write instruction length: 5-64 words
 PLC MSG Read instruction length: 5-64 words

Message Structure

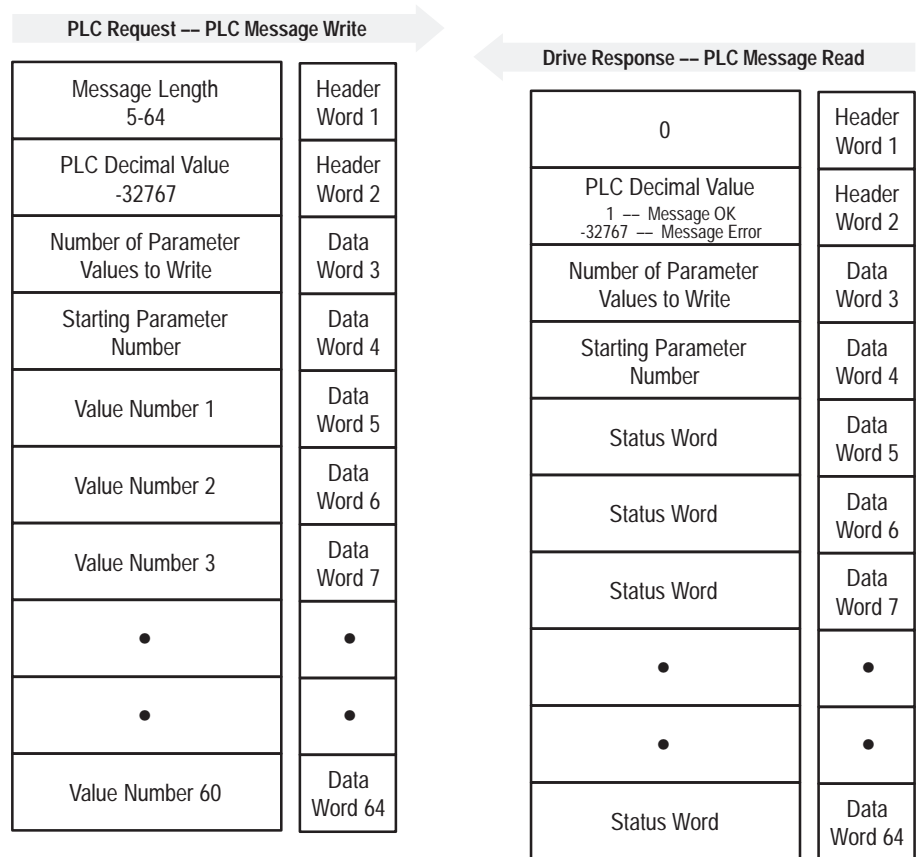

Message Operation

The Continuous Parameter Value Write function specified in the PMW writes data values to a consecutive group of parameters, beginning with the starting parameter number defined in word 4 of the PMW message. The number of parameters to be written to is defined in word 3 of the PMW message.

If an error has occurred in writing to any of the values, the PMR data file status word contains an error code. If no error has occurred, it returns a value of 0.

Continuous Parameter Value
Write
(continued)

Example

In this example, eight 1336 FORCE parameter values were written to, starting with parameter 10. The eight parameter values are in device units. Because all of the parameter values were accepted, values of 0 were returned in the PMR status words.

Data Format

		0	1	2	3	4	5	6	7	8	9
PLC MSG Write File	N7:10	12	-32767	① 6	① 10	① 1	① 1	① 1	① 1	① 1	① 101
	N7:20	① 1	① 51								
PLC MSG Read File	N7:90	0	1	① 8	① 10	① 0	① 0	① 0	① 0	① 0	① 0
	N7:100	① 0	① 0								

① These values vary depending on parameters and products.

Parameter Write

Scattered Parameter Value Write

The Scattered Parameter Value Write function writes to a list of parameters and returns the status of each parameter in its value location. Parameter numbers do not need to be in consecutive order.

PLC Block Transfer Instruction Data

PLC MSG Write instruction length: 5-63 words
 PLC MSG Read instruction length: 5-63 words

Message Structure

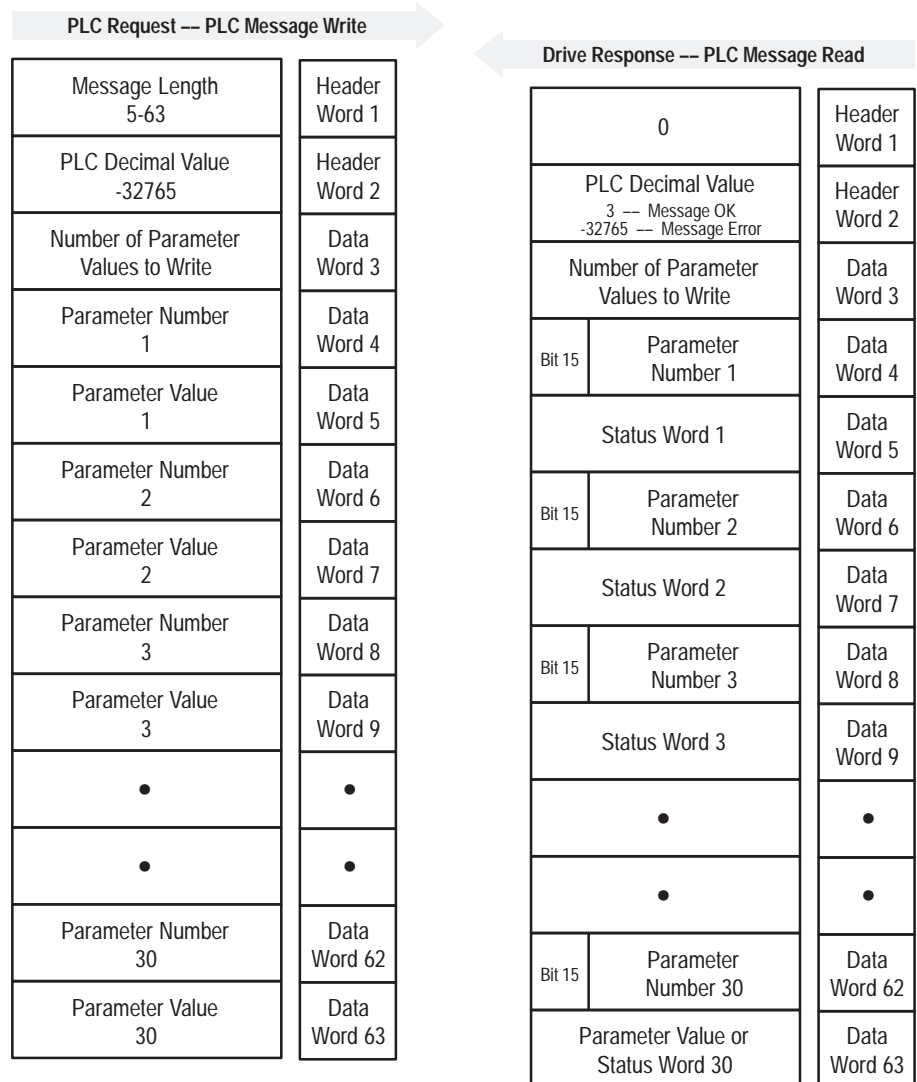

Scattered Parameter Value Write (continued)

Message Operation

The Scattered Parameter Value Write function specified in the PMW writes data values to a defined group of parameters in any order. Word 3 of the PMW data file defines the number of parameters to be written to. The parameters to be written to, and their order is defined starting with word 4. The PMR response message returns a status word for each value written to, indicating whether the parameter write was successful.

If a transfer is not successful for a given parameter, the value in the parameter number location is negative (bit 15 is set to 1).

If an error occurs, the response returns a status code for the error.

Example

In this example, six parameters were written to in a 1336 FORCE. Word 3 of the PMW message (N7:12) defines the number of parameter values that are transferred. Each parameter number followed by its value is listed in the message beginning with Word 4. The values are entered in drive units. The PMR response (N7:90) returns the status of each parameter write.

Note that a value of 600 was sent to parameter 392 (words N7:7 and N7:8). Word N7:91 indicates the block transfer operation was not completely successful. If all parameter values had been successfully transferred, N7:91 would contain the value 3. Word N7:97 contains a negative value indicating the error occurred with parameter 392. Word N7:98 contains the status code indicating the parameter value is out of range.

Data Format

		0	1	2	3	4	5	6	7	8	9
PLC MSG Write File	N7:10	15	-32767	① 6	① 90	① 1	① 150	① 4	① 392	① 6000	① 31
	N7:20	① 10	① 10	① 2	① 12	① 5					
PLC MSG Read File	N7:90	0	-32765	① 6	① 90	① 0	① 150	① 0	① 392	① 6	① 31
	N7:100	① 0	① 10	① 0	① 12	① 0					

① These values vary depending on parameters and products.

Fault Queue

Fault Clear/Reset

The Fault Clear/Reset message activates one of several fault queue related functions shown in the message request.

PLC Block Transfer Instruction Data

PLC Message Write instruction length: 4 words

PLC Message Read instruction length: 4 words

Message Structure

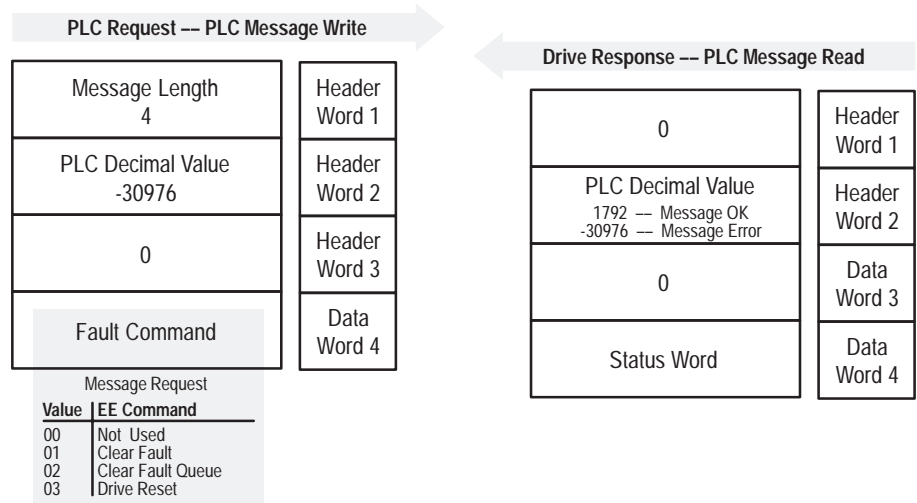

Message Operation

The Fault Clear/Reset function specified in the PMW sends a fault handling request to the drive.

- A Clear Fault Request clears the last fault that occurred and makes the drive available to run.
- A Clear Fault Queue clears the entire fault buffer.
- A Drive Reset resets the drive and clears any parameters or links not saved. Parameter information stored in EEPROM is written to RAM.

If an error has occurred in the block transfer, word 2 of the PMR returns a value of -30976.

Fault Clear/Reset (continued)

Example

In this example, a Fault Clear Request was sent to the drive through the block transfer. The PMR response indicated a successful clear by returning a value of 1792 in word 2, and a value of 0 in word 4.

Data Format

		0	1	2	3	4	5	6	7	8	9
PLC MSG Write File	N7:10	4	-30976	0	1						
PLC MSG Read File	N7:30	0	1792	0	① 0						

① This value varies depending on parameters and products.

Fault Queue

Trip Fault Queue Number

The Trip Fault Queue Number message provides the fault queue number of the fault that caused the drive to trip.

PLC Block Transfer Instruction Data

PLC MSG Write instruction length: 3 words

PLC MSG Read instruction length: 4 words

Message Structure

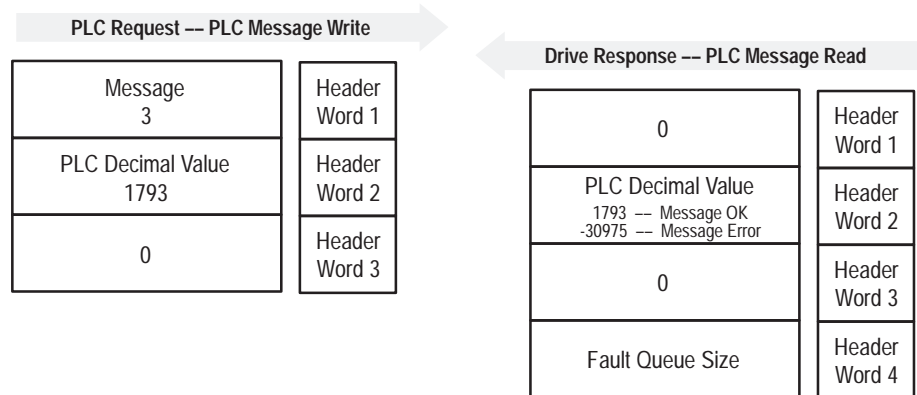

Message Operation

The Trip Fault Queue Number function provides the entry number of the fault in the fault queue that tripped the drive. The PMR response contains that number in word 4. The Fault Queue Number is 0 when the drive is not faulted.

If an error has occurred in the block transfer, word 2 of the response will be -30975.

Example

In this example, the first entry in the drive fault queue has caused the drive to trip. Word 4 of the PMR indicates the entry number.

Data Format

		0	1	2	3	4	5	6	7	8	9
PLC MSG Write File	N7:10	3	1794	0							
PLC MSG Read File	N7:90	0	1794	0	① 1						

① These values vary depending on parameters and products.

Fault Queue

Fault Entry Read Full

The Fault Entry Read Full function reads the contents of the fault queue entry number specified. A message is returned that includes the fault text and fault code associated with the specified fault queue entry and the time stamp associated with the fault.

PLC Block Transfer Instruction Data

PLC Message Write instruction length: 3 words
 PLC Message Read instruction length: 12 or 16 words

Message Structure

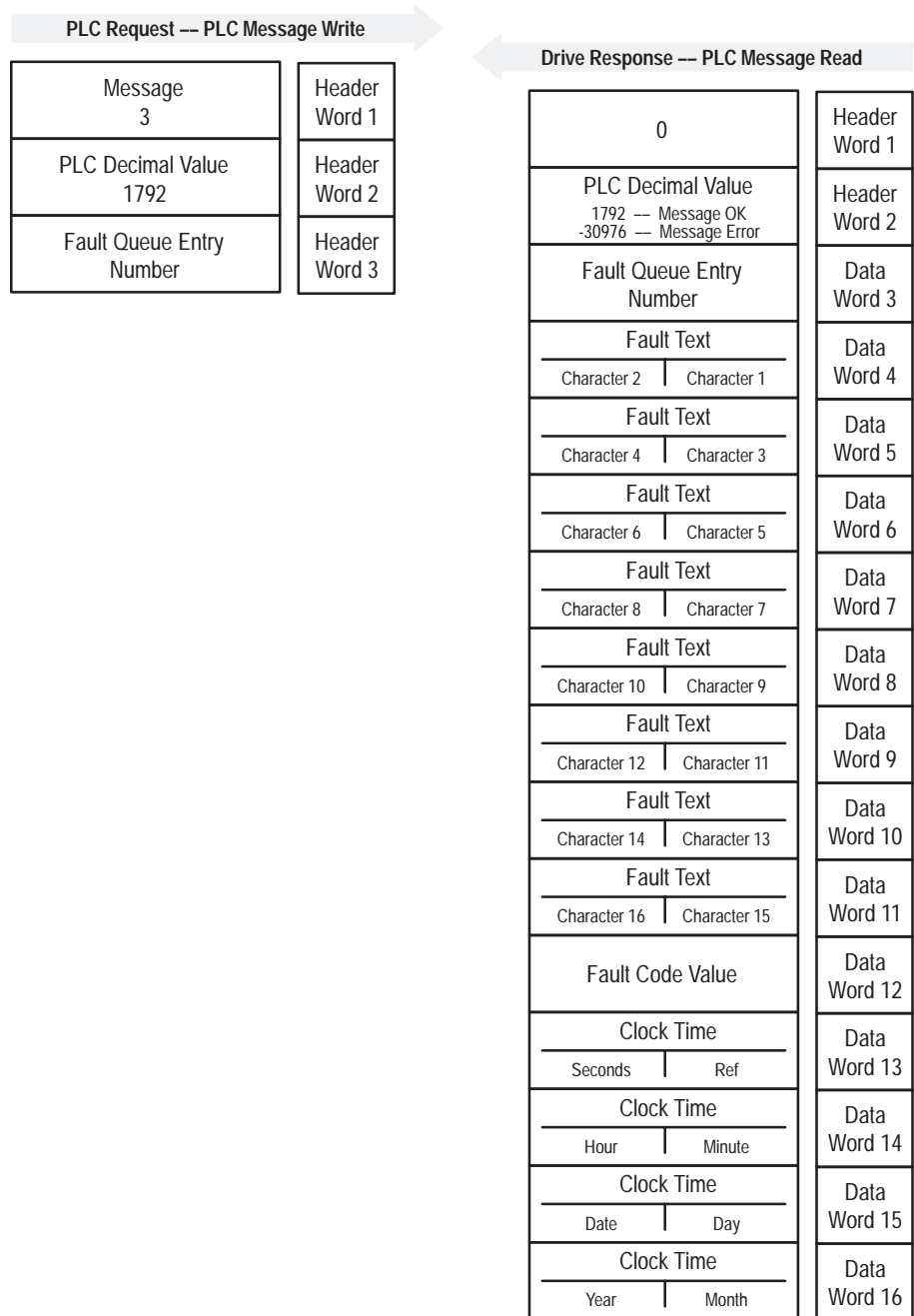

Fault Entry Read Full (continued)

Message Operation

The Fault Queue Entry Read Full function specified in the PMW reads the contents of the fault queue for the input entry number specified in word 3 of the PMW message. The response returns the fault text which you can view as ASCII text. The text will have every two characters in reverse order and return a time stamp, indicating the day and time the fault occurred. The Clock Time is returned in the order shown in the header message. You should view this information as ASCII text.

This field:	Indicates:
Reference	am or pm, where 0 is am and 1 is pm.
Date	The date of the month in ASCII.
Day	The day of the week, where 1 is Sunday and 7 is Saturday.
Year	The number of the year. 1990 is referenced as 0. Therefore, the year 1995 would return a value of 5.
Month	The month of the year, where 1 is January and 12 is December.

If an error has occurred, word 2 of the response returns a negative value.

Example

In this example, Fault Queue Entry #3 was retrieved from the drive. The PMR response returned the ASCII text Drive Reset Flt, with each two characters reversed. The Fault Code for this example is 22.

Data Format

		0	1	2	3	4	5	6	7	8	9
PLC MSG Write File	N7:10	3	1792	① 3							
PLC MSG Read File	N7:30	0	1792	① 3	① 29252	① 30313	① 8293	① 25938	① 25971	① 8308	① 27718
	N7:100	① 8308	① 22	7681	3594	5893	1282				
	N7:90	0	07\00	03\00	rD	Vi	e	eR	es	t	lF
	N7:100	t	00\16	1E\01	0E\0A	17\05	05\02				

ASCII Display Values

① These values vary depending on parameters and products.

Warning Queue

Warning Clear

The Warning Clear message issues either a Clear Fault/Warning command or a Clear Warning Queue command to the drive.

PLC Block Transfer Instruction Data

PLC Message Write instruction length: 4 words

PLC Message Read instruction length: 4 words

Message Structure

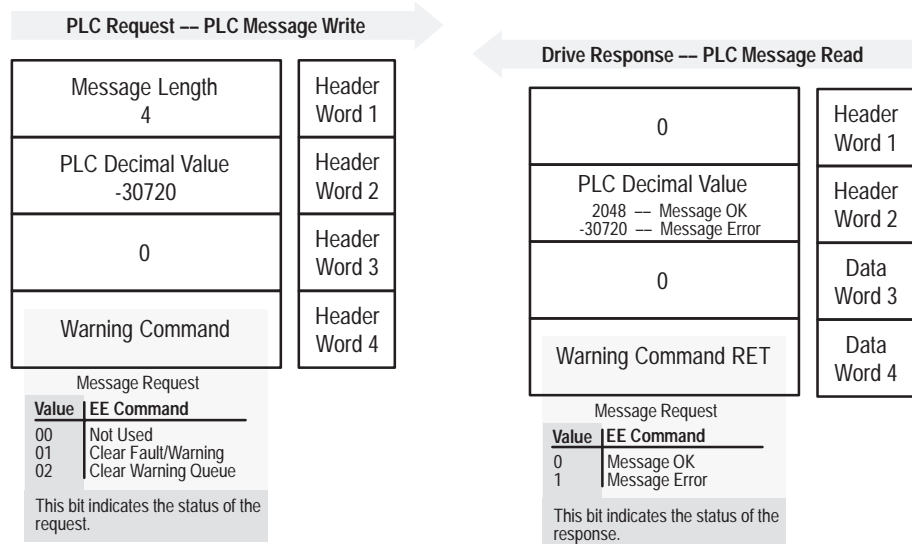

Message Operation

The Warning Clear function specified in the PMW sends a warning fault handling request to the drive. Word 4 of the PMW defines which handling option is requested:

- If word 4 has a value of 1, this message clears the last fault.
- If word 4 has a value of 2, this message clears the entire warning fault queue.

If an error has occurred in the request, word 2 of the PMR returns a value of -30975. Word 4 of the PMR responds to the request of PMW word 4.

Warning Clear
(continued)**Example**

In this example, a Clear Fault/Warning request was sent to the drive by putting a value of 1 in word 4 of the PMW. Word 2 of the PMR indicated a successful clear by returning a value of 2048.

Data Format

		0	1	2	3	4	5	6	7	8	9
PLC MSG Write File	N7:10	4	-30720	0	01						
PLC MSG Read File	N7:90	0	2048	0	1						

Warning Queue

Warning Queue Read Full

The Warning Queue Read Full function reads the contents of the specified warning queue entry number. A message is returned that includes the warning text and warning code associated with the specified warning queue entry and the time stamp associated with the fault.

PLC Block Transfer Instruction Data

PLC Message Write instruction length: 3 words
 PLC Message Read instruction length: 16 words

Message Structure

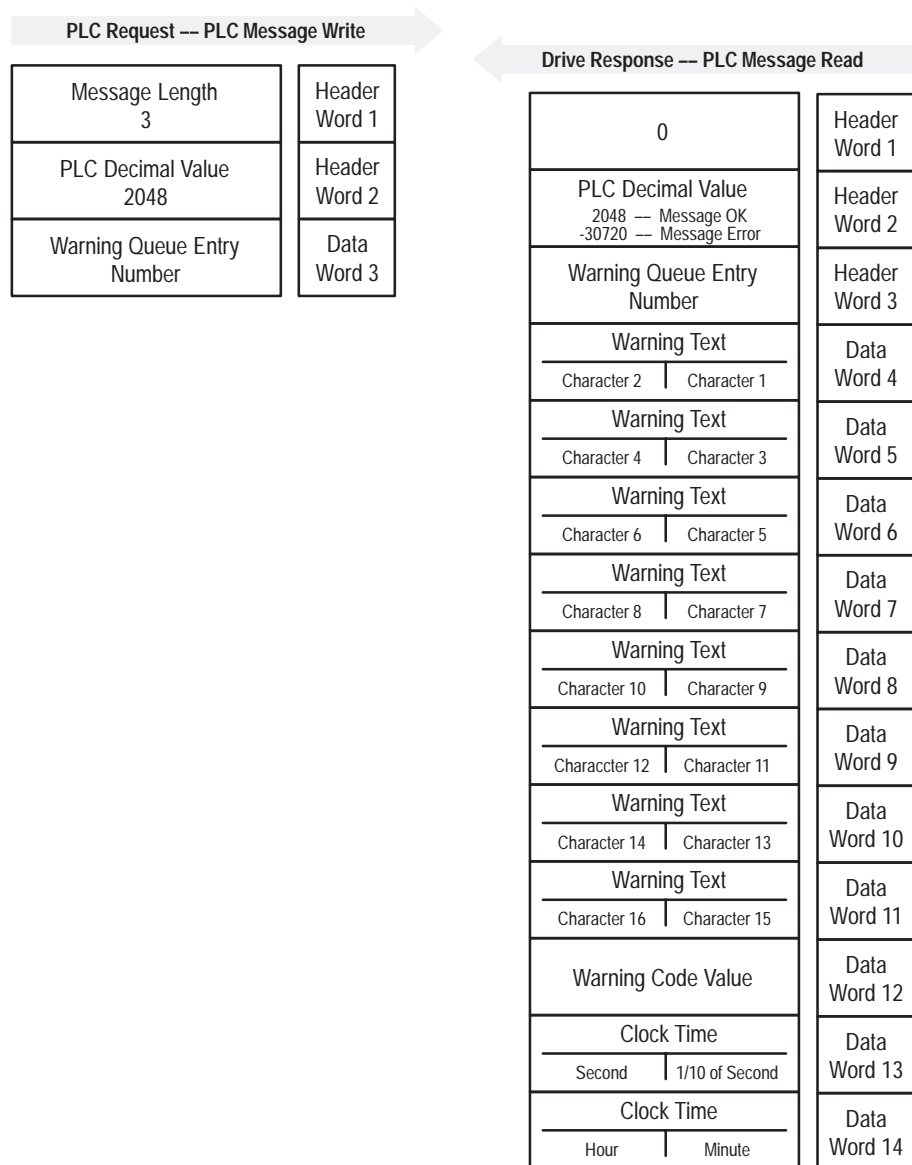

Warning Queue Read Full (continued)

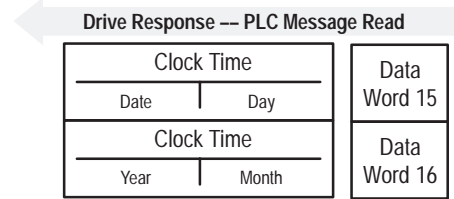

Message Operation

The Warning Queue Entry Read Full function specified in the PMW reads the contents of the warning queue specified in word 3 of the PMW message. The response returns the warning text which can be shown as ASCII text. The text will have every two characters in reverse order and return a time stamp indicating the day and time the warning occurred. The Clock Time is returned in the order shown in the header message. You should view this information as ASCII text.

This field:	Indicates:
Day	The day of the week, where 1 is Sunday and 7 is Saturday.
Year	The number of the year. 1990 is referenced as 0. Therefore, the year 1995 would return a value of 5.
Month	The month of the year, where 1 is January and 12 is December.

The Date and Time are in hexadecimal format.

Example

In this example, Warning Queue Entry #1 was retrieved from the drive. The PMR returned the ASCII text Vel Fdbk Loss, with each two characters reversed. The fault occurred at 10:14am on Thursday February 23, 1995.

Data Format

		0	1	2	3	4	5	6	7	8	9
PLC MSG Write File	N10:10	3	2048	1							
PLC MSG Read File	N10:90	0	2048	1	25942	8300	25670	27490	19488	29551	8307
	N10:100	8224	5048	7681	3594	5893	1282				
	N10:90	00\00	08\00	00\01	eV	l	df	kb	L	so	s
	N10:100	00\00	13\B8	1E\01	0E\0A	17\05	05\02				

ASCII Display Values

EE Memory Request

Save/Recall/Initialize

This message is sent by the PLC Communications Adapter Board to activate the BRAM functions detailed in the message request.

PLC Block Transfer Instruction Data

PLC Message Write instruction length: 4 words

PLC Message Read instruction length: 3 words

Message Structure

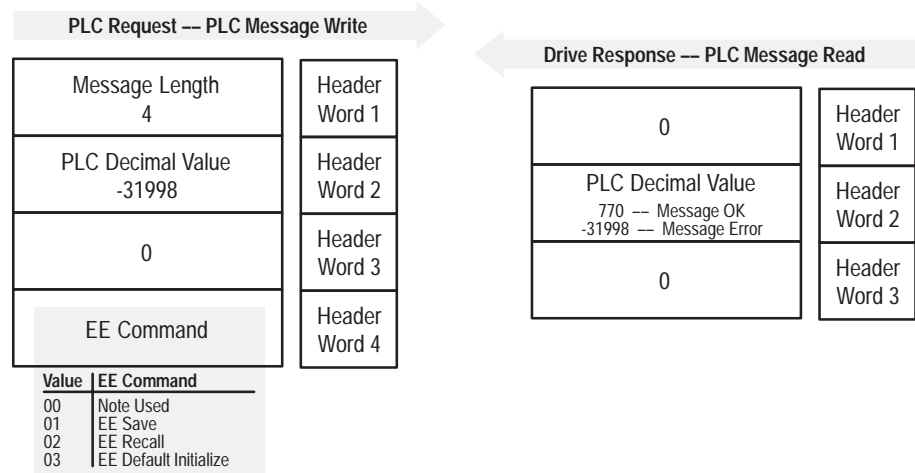

Message Operation

The BRAM memory function allows three different message requests:

- BRAM Save saves parameter and link information from working memory or RAM to BRAM.
- EE Recall retrieves the last saved data from BRAM and places it in working memory or RAM.
- EE Default Initialize sets all parameter values and links to default in RAM without altering contents in BRAM.

If an error has occurred, word 2 of the response returns a value of -31998.

Save/Recall/Initialize
(continued)

Example

This example is requesting an EEPROM save.

Data Format		0	1	2	3	4	5	6	7	8	9
PLC MSG Write File	N7:10	4	-31998	① 0	① 1						
PLC MSG Read File	N7:90	0	770	① 0							

① These values vary depending on parameters and products.

Link Read

Link Parameter Read

The Link Parameter Read message reads the source parameter number that is linked to the specified sink parameter.

PLC Block Transfer Instruction Data

PLC Message Write instruction length: 3 words

PLC Message Read instruction length: 4 words

Message Structure

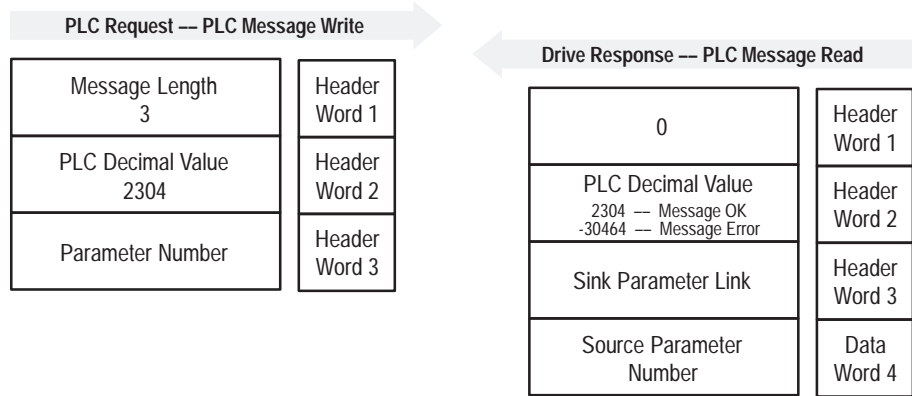

Message Operation

The Link Parameter Read function specified in the PMW reads the source parameter that is linked to the requested sink parameter, defined in word 3 of the header message. The source parameter is returned in word 4 of the PMR.

If an error has occurred, word 2 of the PMR returns a value of -30464.

Example

In this example, the link associated with parameter 101 was requested from the drive. The PMW header message word 4 defines the sink parameter of the requested link with a value of 101. The linked source parameter 330 is returned in word 4 of the PMR.

Data Format

		0	1	2	3	4	5	6	7	8	9
PLC MSG Write File	N7:0	3	2304	101	0						
PLC MSG Read File	N7:90	0	2304	101	330						

Link Read

Continuous Parameter Link Read

The Continuous Parameter Link Read message returns a list of up to 60 parameters that are linked to each drive parameter in a consecutive list.

PLC Block Transfer Instruction Data

PLC Message Write instruction length: 4 words

PLC Message Read instruction length: 5-64 words

Message Structure

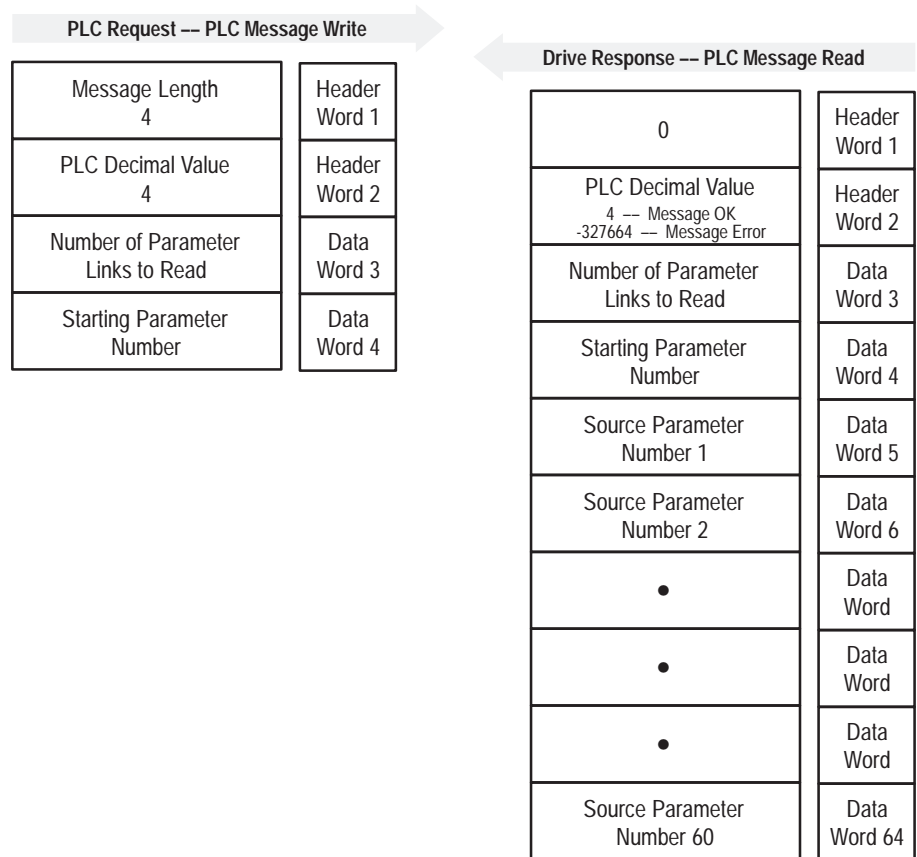

Message Operation

The request must specify the number of links to be read and the starting sink parameter number. The response returns the parameter number of the source that is linked to each sink parameter. The response returns links for a consecutive list of sink parameters (up to 60 links). If a parameter is not linked, a value of 0 is returned.

Continuous Parameter Link Read (continued)

Example

A Continuous Parameter Link Read is requested for nine parameter links (word N7:2) beginning with parameter 359. The block transfer response returns the source parameters that are linked to parameters 359 through 367. In this example:

- Parameter 359 is linked to parameter 56.
- Parameter 360 is linked to parameter 143.
- Parameter 367 is linked to parameter 380.
- Parameters 361 through 366 are not linked.

Data Format

		0	1	2	3	4	5	6	7	8	9
PLC MSG Write File	N7:0	4	4	9	359						
PLC MSG Read File	N7:90	0	4	9	359	56	143	0	0	0	0
	N7:100	0	0	380							

Link Read

Scattered Parameter Link Read

The Scattered Parameter Link Read message returns a list of up to 30 links in the source-to-sink order found in the drive. The links do not have to be in consecutive order.

PLC Block Transfer Instruction Data

PLC Message Write instruction length: 5-63 words
 PLC Message Read instruction length: 5-63 words

Message Structure

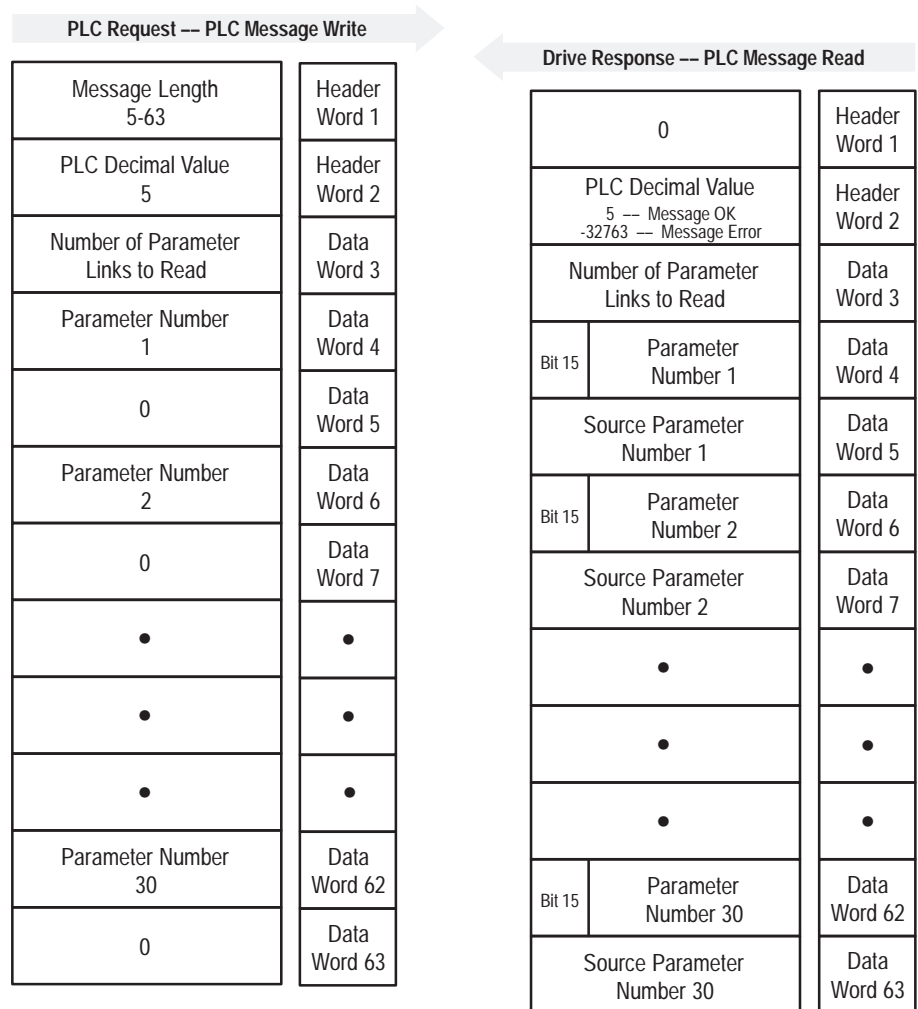

Message Operation

The Scattered Parameter Link Read function requested in the PMW reads up to 30 non-consecutive links made in the drive. You request the desired link information by defining the sink parameters in the PMW message.

Scattered Parameter Link Read (continued)

The corresponding source parameters are returned through the PMR response.

If an error has occurred in reading any of the links:

- Word 2 of the PMR returns a value of -32763.
- Bit 15 of the PMR word for the number of that link is set, making the value negative.

Example

In this example, a Scattered Parameter Link Read of four links was requested through the PMW. Sink parameters 119 through 367 and 401 were defined as the desired links to be read. The PMR returned the corresponding source parameter values in the words reserved for this information. If an error had occurred for a specific link, the value returned would be negative.

Data Format		0	1	2	3	4	5	6	7	8	9
PLC MSG Write File	N7:10	12	5	4	119	0	368	0	367	0	401
	N7:20	0									
PLC MSG Read File	N7:90	0	5	4	119 Sink	0 Source	368 Sink	331 Source	367	330	401
	N7:100	0									

Link Write

Link Parameter Write

The Link Parameter Write message writes the source parameter link to the linkable sink parameter. This function writes only one link.

PLC Block Transfer Instruction Data

PLC instruction length: 4 words

PLC instruction length: 4 words

Message Structure

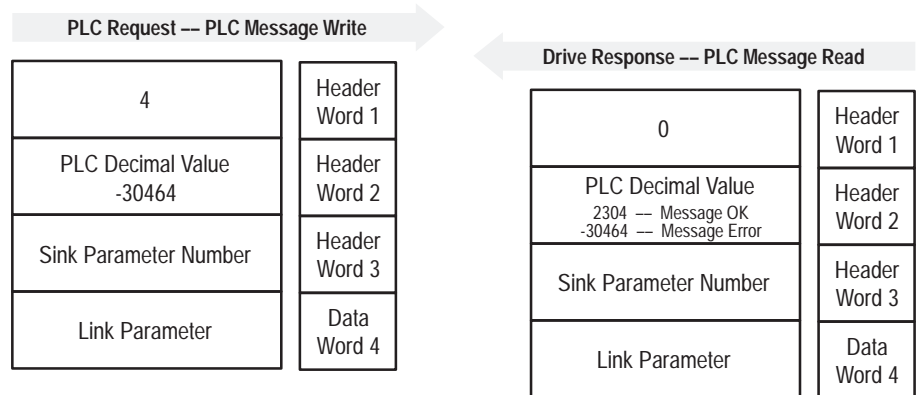

Message Operation

The Link Parameter Write function specified in the PMW writes the corresponding source parameter link to the defined linkable sink parameter. The sink parameter is defined in word 3 of the PMW data file with its linked source defined in word 4.

If an error has occurred in the link, word 2 of the PMR returns a value of -30464.

Example

In this example, a link was defined between the sink parameter defined in word 3 (parameter 101, External Velocity Reference), and the source parameter (parameter 340, Analog Input 2). The PMR header message confirmed the link by returning a value of 2034 in word 2, and the link in order of sink-to-source in words 3 and 4.

Data Format

		0	1	2	3	4	5	6	7	8	9
PLC MSG Write File	N7:0	4	-30464	101	340						
PLC MSG Read File	N7:0	0	2304	101	340						

Link Write

Continuous Parameter Link Write

The Continuous Parameter Link Write message writes a list of up to 60 consecutive links to the drive, starting at the defined sink parameter.

PLC Block Transfer Instruction Data

PLC Message Write instruction length: 5-64 words
 PLC Message Read instruction length: 5-64 words

Message Structure

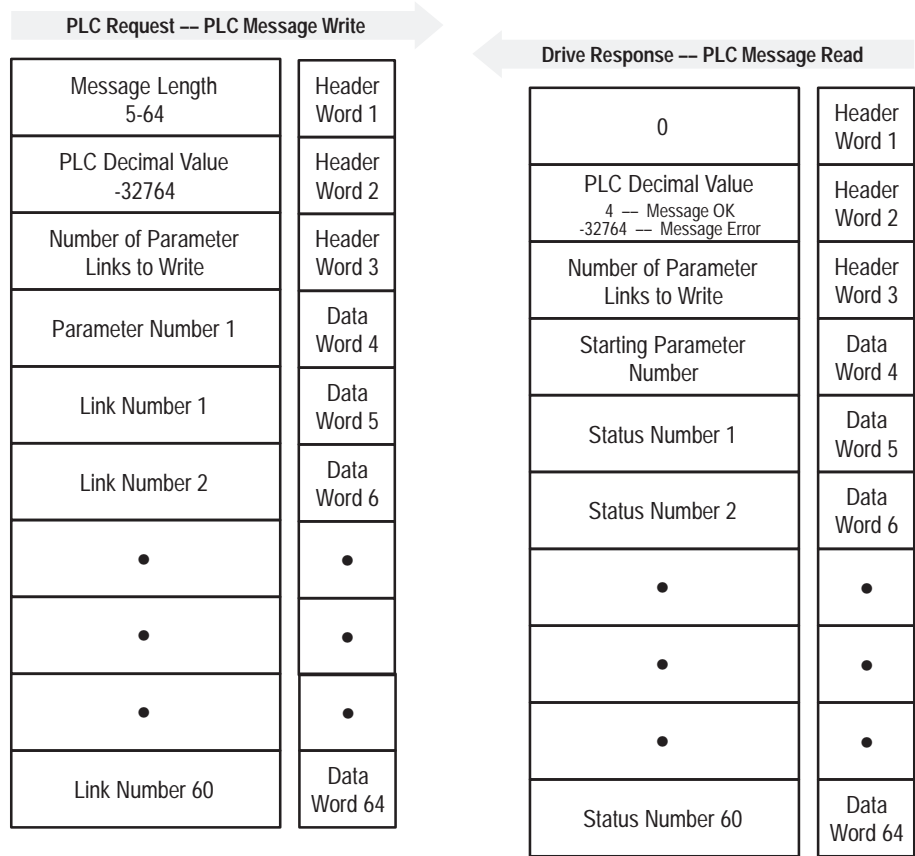

Message Operation

The Continuous Parameter Link Write function specified in the PMW writes a set of consecutive links to the drive. Word 3 of the PMW defines the number of links to be written. Word 4 defines the starting sink parameter. The consecutive link source parameters are then listed in the remaining header words. You can make up to 60 continuous links with this block transfer function.

Continuous Parameter Link Write
(continued)

Example

In this example, a group of four continuous links were sent to the drive, starting at parameter 119. Word 3 of the PMW header message defines a length of four links. Word 4 defines the starting link sink parameter 119. Words 5 through 8 list the source parameters that are linked to the four continuous sink parameters, parameters 119 through 122. The PMR message returns the status of the write request. Zeros returned in words 5 through 8 indicate that the write was successful.

Data Format

		0	1	2	3	4	5	6	7	8	9
PLC MSG Write File	N7:0	8	-32764	4	119	339	340	341	342		
PLC MSG Read File	N7:90	0	4	4	119	0	0	0	0		

Link Write

Scattered Parameter Link Write

The Scattered Parameter Link Write function writes a scattered group of links to the drive.

PLC Block Transfer Instruction Data

PLC Message Write instruction length: 5-63 words

PLC Message Read instruction length: 5-63 words

Message Structure

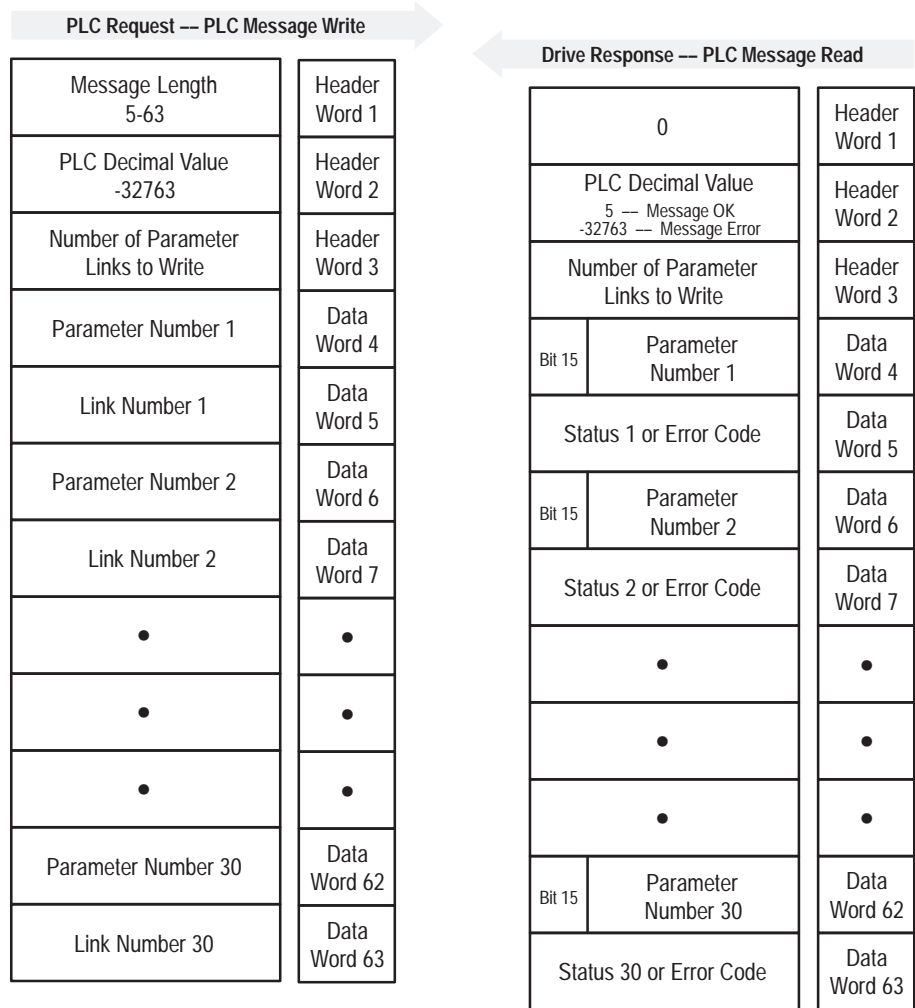

Message Operation

The Scattered Parameter Link Write function in this PMW writes up to 30 non-consecutive links in any order from the drive. Word 3 of the PMW defines the number of links to write.

Scattered Parameter Link Write (continued)

The links are then defined, followed by each sink's corresponding source in the remainder of the header message. You can define up to 30 scattered links with this function. If an incorrect link is defined, the PMR response returns a negative value for the sink parameter, followed by a status or error code.

If there is an error in the block transfer, word 2 of the PMR contains a value of -32763.

Example

In this example, four scattered links were written to the drive as defined in word 3 of the PMW. Words 4 and 5 (N7:3 and N7:4) contain the first link with word 4 defining the sink parameter, and word 5 the corresponding source. Words 6 and 7 (N7:5 and N7:6) contain the next link, in the order of sink-to-source. The remaining two links are contained in words 8 through 11 (N7:7-10). The PMR responds with 0 in place of the source parameter to indicate a successful link.

Data Format

		0	1	2	3	4	5	6	7	8	9
PLC MSG Write File	N7:0	11	-32763	4	387	146	388	168	367	330	368
	N7:20	331									
PLC MSG Read File	N7:90	0	5	4	387	0	388	0	367	0	368
	N7:100	0									

Link Write

Parameter Link Clear

The Parameter Link Clear message deletes all user-configured parameter links in the drive.

PLC Block Transfer Instruction Data

PLC Message Write instruction length: 4 words

PLC Message Read instruction length: 3 words

Message Structure

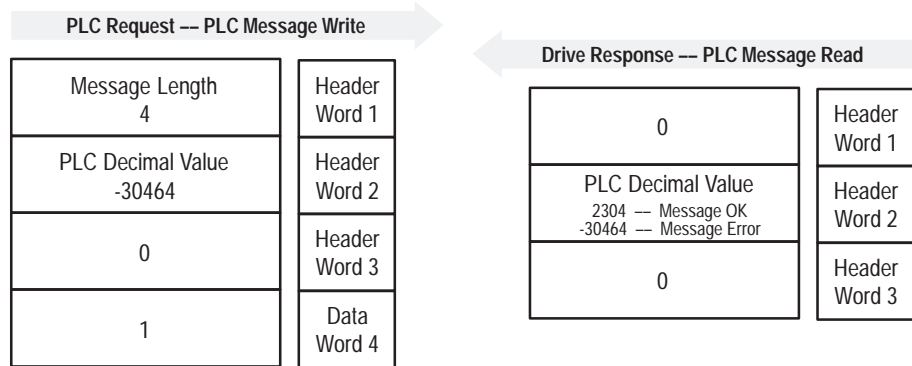

Message Operation

When this request is sent to the drive, all drive parameter links that you configured are deleted.

If an error has occurred, word 2 of the PMR returns -30464.

Example

In this example, a Parameter Link Clear request was sent through the PMW. The PMR was only required to check for an error.

Data Format

		0	1	2	3	4	5	6	7	8	9
PLC MSG Write File	N7:0	4	-30464	0	1						
PLC MSG Read File	N7:90	0	2304	0							

User Text String

User Text String Read

This read-only message retrieves from the drive the user custom product name/location test string which identifies the product. The text string is 16 characters long.

PLC Block Transfer Instruction Data

PLC Message Write instruction length: 3 words
 PLC Message Read instruction length: 11 words

Message Structure

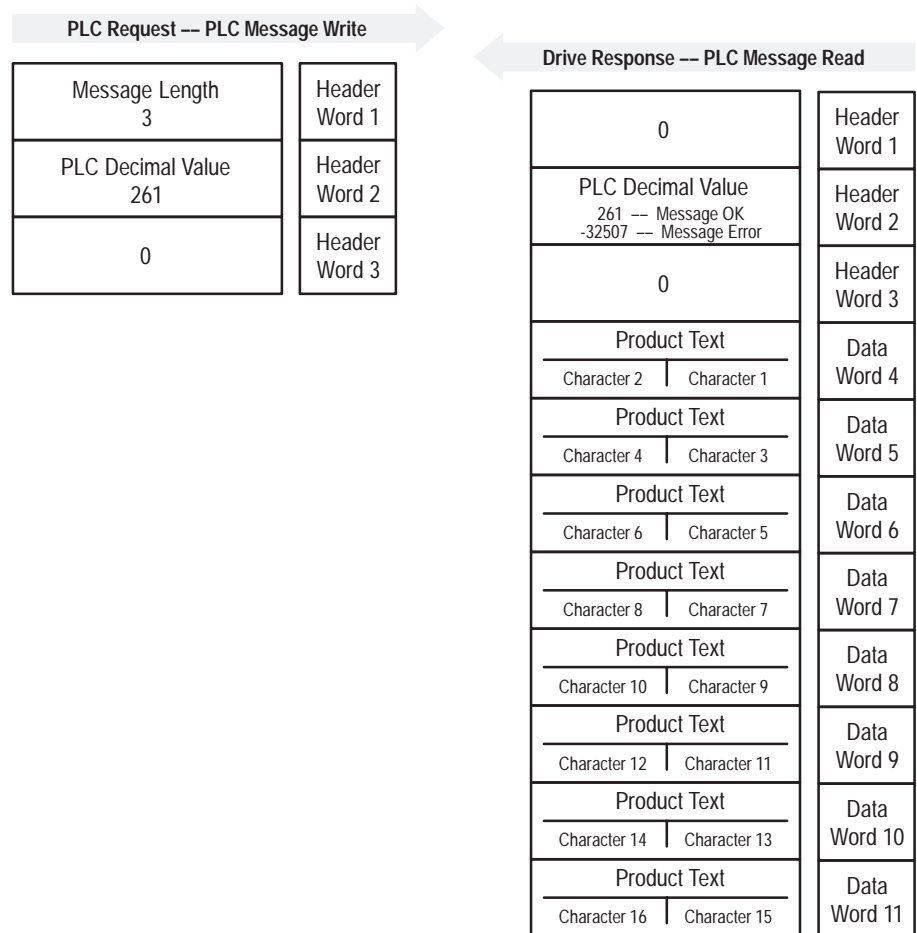

Message Operation

This operation reads your custom product test string stored in the drive. The response message returns this information beginning with data word 4. The text string is returned with each data word containing two ASCII characters per word. This data returns with the first and second characters in opposite order as shown in the example.

User Text String Read (continued)

If an error has occurred in the PMW, word 2 of the PMR returns a value of -32507.

Example

In this example, the PMW defined a User Text String Read request in word 2 of the PMW with a value of 261. The PMR responds by returning a value of 261 in word 2, indicating a successful read. In addition, it returned the user text string in data words 4 through 11 stored in the drive. The characters of each word are returned in reverse order. The user text string should read Press 8 Level 2.

Data Format

		0	1	2	3	4	5	6	7	8	9
PLC MSG Write File	N7:10	3	261	0							
	N7:20	\00\03	\01\05	\00\00							
PLC MSG Read File	N7:20	0	261	0	21072	21317	8275	8248	17740	17750	8268
	N7:100	12832									
	N7:90	00\00	01\05	00\00	rP	se	s	8	el	ev	L
	N7:100	2									

ASCII Display Values

User Text String

User Text String Write

This is a write message that stores in the drive your custom product name/location text string which identifies the product. The text string is 16 characters long.

PLC Block Transfer Instruction Data

PLC Message Write instruction length: 11 words
 PLC Message Read instruction length: 4 words

Message Structure

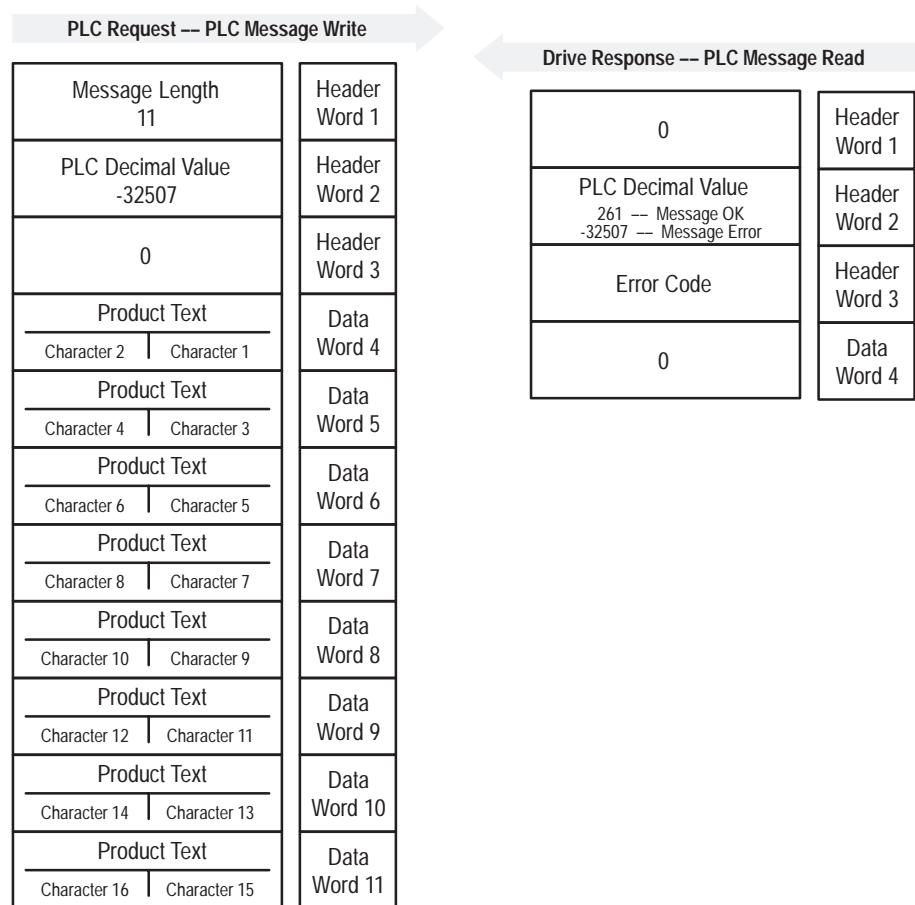

Message Operation

The User Text String Write allows you to write a custom product identification string to the drive. This string can be 16 ASCII characters long and is defined in the 8 words of the PMW. You must enter the characters in the order shown, with the first and second character of each word entered in opposite order as shown in the example.

User Text String Write (continued)

Example

In this example, the PMW defined a text string of Press 8 Level 2 to be written to the drive. This information was entered in ASCII text, with the two characters of each word entered in opposite order. The PMR returned a value of 261 in word 2, indicating a successful write. In addition, it returned the text string in words 4 through 11.

If an error had occurred in the PMW, the PMR would have returned an error code in word 3 of -32507.

Data Format

		0	1	2	3	4	5	6	7	8	9
PLC MSG Write File	N7:10	11	-32507	0	21072	21317	8275	8248	17740	17750	8268
	N7:20	12832									
	N7:10	00\0B	7E\VB	00\00	rP	se	s	8	el	ev	L
	N7:20	2									
PLC MSG Read File	N7:90	0	261	0	21072	21317	8275	8248	17740	17750	8268
	N7:100	12832									

ASCII Display Values

Clock Data

Real Time Clock Data Read

The Real Time Clock Data Read message is provided to allow the drive to read the specified real-time clock. The slave device can read the time in seconds, minutes, and hours as well as the day, date, month, and year.

PLC Block Transfer Instruction Data

PLC Message Write instruction length: 3 words

PLC Message Read instruction length: 7 words

Message Structure

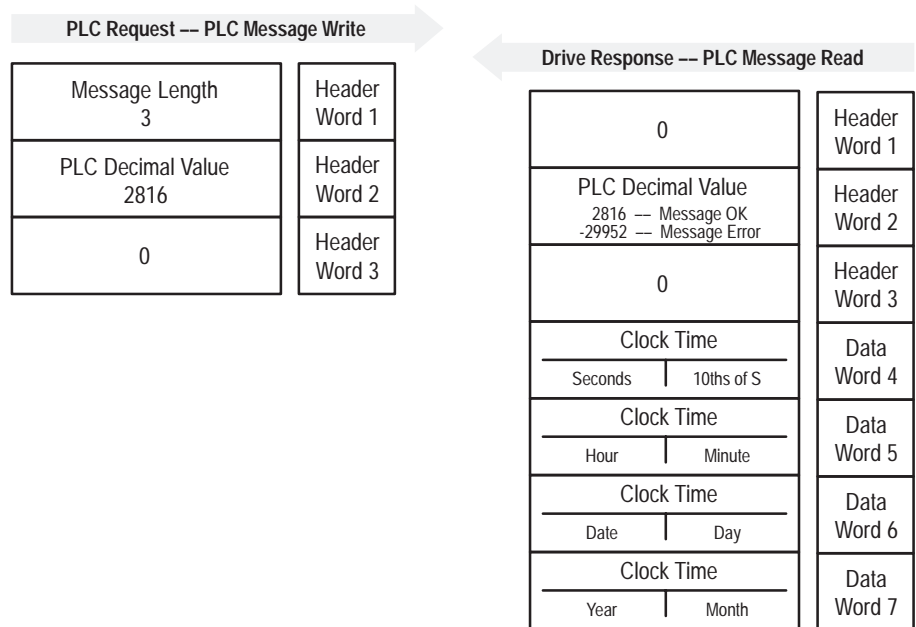

Message Operation

The Real Time Clock Data Read function reads the real-time clock data from the drive. The Clock Time is returned in the order shown in the header message. You should view this information as hex text.

The Time is based on a 24-hour clock.

Real Time Clock Data Read (continued)

This field:	Indicates:
Seconds	The seconds and hundredths of seconds.
Date	The date of the month in Hex.
Day	The day of the week, where 1 is Sunday and 7 is Saturday.
Year	The number of the year. 1990 is referenced as 0. Therefore, the year 1995 would return a value of 5.
Month	The month of the year, where 1 is January and 12 is December.

If an error occurs in the block transfer, a value of -29952 is returned in word 2 of the PMR response.

Example

In this example, the clock was read with a value of 2816 in word 2 of the PMW. The PMR response indicated a successful read with a value of 2816 in word 2.

- Word 4 indicated a changing value for seconds.
- The Hour value 0E indicates hour 14 of a 24 hour clock, or 2 pm. The minute value 0A indicates 10, or 2:10 pm.
- The Date of 17 in Hex is the 23rd and the 5th day of the week, or Thursday.
- The Year 05 is 1995.
- The Month of 02 is February.

Data Format

		0	1	2	3	4	5	6	7	8	9
PLC MSG Write File	N7:10	3	2816	0							
PLC MSG Read File	N7:90	0	2816	0	7681	3594	5893	1282			
	N7:90				0E\01 Sl..01S	0E\0A Hr\Min	17\05 Date\Day	05\02 Yr\Mth			

Clock Data

Real Time Clock Data Write

The Real Time Clock Data Write message is provided to allow the drive to write the specified real-time clock data. This allows you to write the new real-time clock seconds, minutes, and hours, as well as the day, date, month, and year.

PLC Block Transfer Instruction Data

PLC Message Write instruction length: 7 words

PLC Message Read instruction length: 3 words

Message Structure

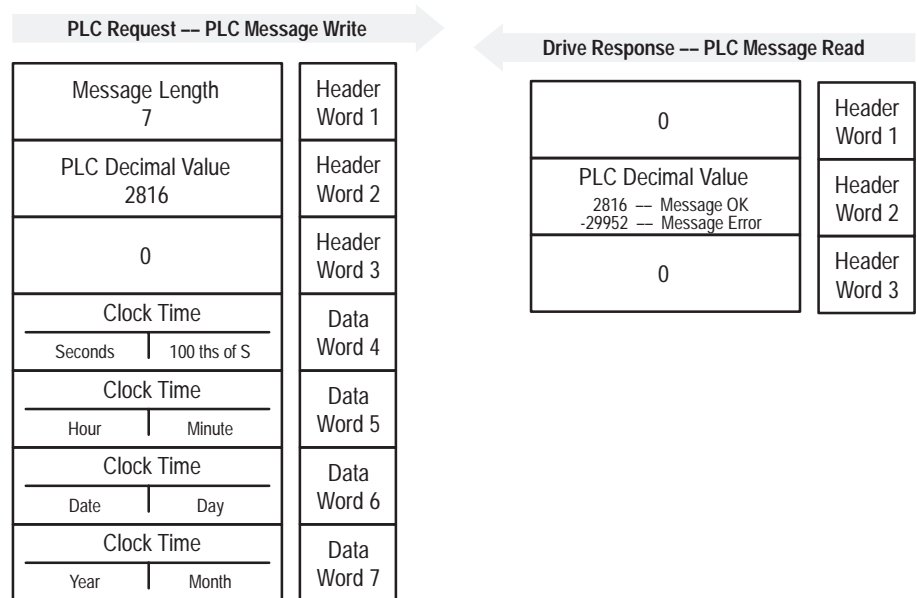

Message Operation

The Real Time Clock Data Write function allows you to define the clock data for the drive. The clock time is written in the order shown in the header message. This information should be sent as ASCII text.

The Time is based on a 24-hour clock.

Real Time Clock Data Write (continued)

This field:	Indicates:
Seconds	The seconds and tenths of milliseconds.
Date	The date of the month in ASCII.
Day	The day of the week, where 1 is Sunday and 7 is Saturday.
Year	The number of the year. 1990 is referenced as 0. Therefore, the year 1995 would return a value of 5.
Month	The month of the year, where 1 is January and 12 is December.

If an error occurs in the block transfer, a value of -29952 is returned in word 2 of the PMR response.

Example

In this example, a real-time clock data value of Friday, February 10, 1995 12:00 am was written to the drive. Word 2 defines the request with a value of 2817.

- Word 4 defines 0 seconds.
- Word 5 defines 12:00.
- Word 6 defines the sixth day (Friday) with a date of the tenth.
- Word 7 defines 1995 and the second month (February).

Data Format

		0	1	2	3	4	5	6	7	8	9
PLC MSG Write File	N7:10	7	2816	0	0000	0000	2566	1283			
	N7:10				00\01 Sl.1S	00\00 Hr\Min	0A\06 Date\Day	05\02 Yr\Mth			
PLC MSG Read File	N7:90	0	2816	0							

ASCII Display Values

Run Time Accumulator

Run Time Accumulator Data Read

The Run Time Accumulator Data Read message provides the drive with the accumulated time for running services. This information is in hours and is read only. This function is typically used as a maintenance feature.

PLC Block Transfer Instruction Data

PLC Message Write instruction length: 3 words
 PLC Message Read instruction length: 4 words

Message Structure

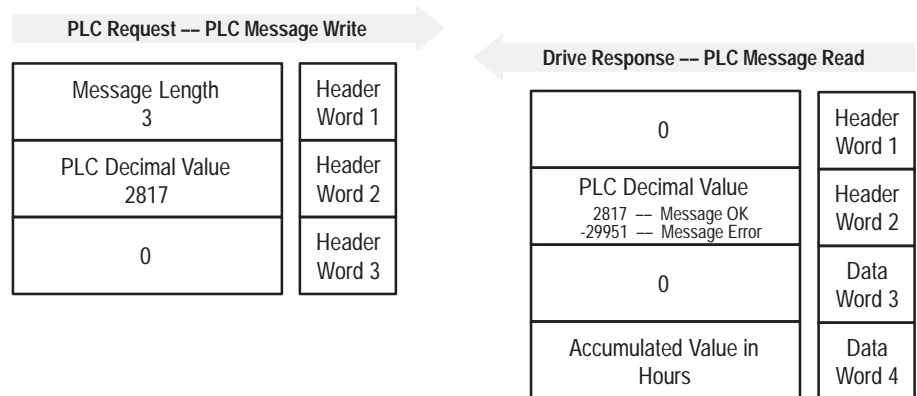

Message Operation

The Run Time Accumulator Data Read through PMR word 4, provides the running service time in hours. As a maintenance feature, you can use this information to help define a service schedule for the drive.

You can clear the accumulated time through a Clear Run Time Accumulator request. Information can then provide the accumulated run time between each scheduled service.

Run Time Accumulator Data
Read
(continued)

Example

In this example, the PMW requested the accumulated running time of the drive. The PMR response returned a value of 41 in word 4, indicating a running time of 41 hours. This value can be monitored, and when a specified running time has accumulated, a maintenance down time can be scheduled.

Data Format

		0	1	2	3	4	5	6	7	8	9
PLC MSG Write File	N7:10	0	2817	0							
PLC MSG Read File	N7:90	0	2817	0	41						

Run Time Accumulator

Clear Run Time Accumulator

The Clear Run Time Accumulator message provides a way of clearing the run time accumulator data stored in the drive.

PLC Block Transfer Instruction Data

PLC Message Write instruction length: 3 words

PLC Message Read instruction length: 3 words

Message Structure

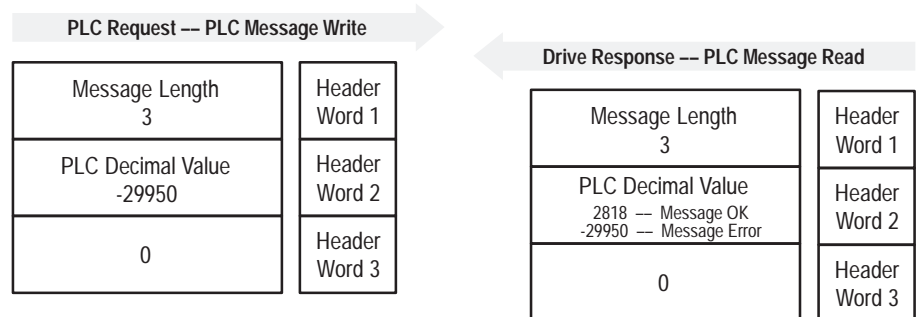

Message Operation

The Clear Run Time Accumulator defines a value of -29950 in the PMW. Word 2 can clear the accumulated run time stored in the drive. This allows you to monitor an accumulated time based on a specific event.

Example

This function was requested to clear the accumulated run time in the drive since the last scheduled maintenance downtime. In this example, the PMW requested a clear with a value of -29950 in word 2. The PMR response indicated a successful clear by returning a value of 2818 in word 20 of the PMR header message.

Data Format

		0	1	2	3	4	5	6	7	8	9
PLC MSG Write File	N10:10	3	-29950	0							
PLC MSG Read File	N10:90	3	2818	0							

Time Stamp

Reference Time Stamp Data Read

The Reference Time Stamp Data Read message reads the reference time stamp value from the drive.

PLC Block Transfer Instruction Data

PLC Message Write instruction length: 3 words

PLC Message Read instruction length: 7 words

Message Structure

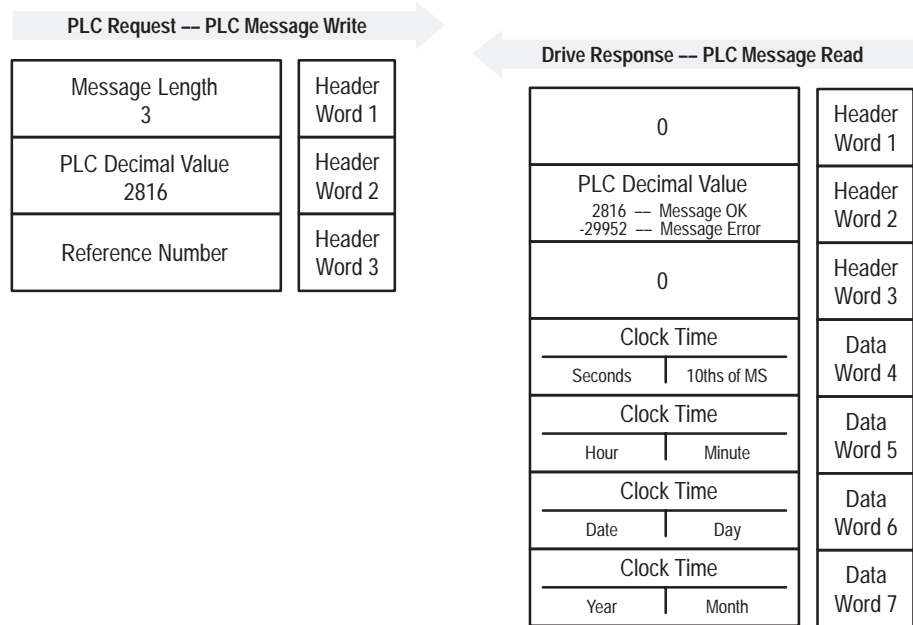

Message Operation

You can define the reference time stamp to monitor the time of a specific event. This function allows this time to be read from the device. The time stamp is returned in the order shown in the header message. This information should be viewed as ASCII text.

The Time is based on a 24-hour clock.

This field:	Indicates:
Seconds	The seconds and tenths of milliseconds.
Date	The date of the month in ASCII.
Day	The day of the week, where 1 is Sunday and 7 is Saturday.
Year	The number of the year. 1990 is referenced as 0. Therefore, the year 1995 would return a value of 5.
Month	The month of the year, where 1 is January and 12 is December.

Reference Time Stamp Data
Read
(continued)

If an error occurs in the PMW, a value of -29952 is returned in word 2 of the PMR response.

Example

In this example, a reference time stamp data read was requested through the PMW. Word 2 of the PMW defines this request with a decimal value of 2816 for the PLC command code. The PMR response indicates a successful request with a returned value of 2816 in PMR word 2. Words 4 through 7 then return the clock data. The clock data indicates a time stamp of February 1995, the fifth day of the week (Thursday), and a date of 23 (17 in ASCII). The hour, minutes, and seconds change according to the time.

Data Format

		0	1	2	3	4	5	6	7	8	9
PLC MSG Write File	N7:10	3	2816	0							
PLC MSG Read File	N7:10	0	2816	0	7681	3594	5893	1282			
	N7:90				0E\01 Sl..01S	0E\0A Hr\Min	17\05 Date\Day	05\02 Yr\Mth			

ASCII Display Values

Time Stamp

Reference Time Stamp Data Write

The Reference Time Stamp message is provided to allow the drive to write the specified real-time clock. This allows the drive to write a new reference stamp.

PLC Block Transfer Instruction Data

PLC Message Write instruction length: 7 words
 PLC Message Read instruction length: 3 words

Message Structure

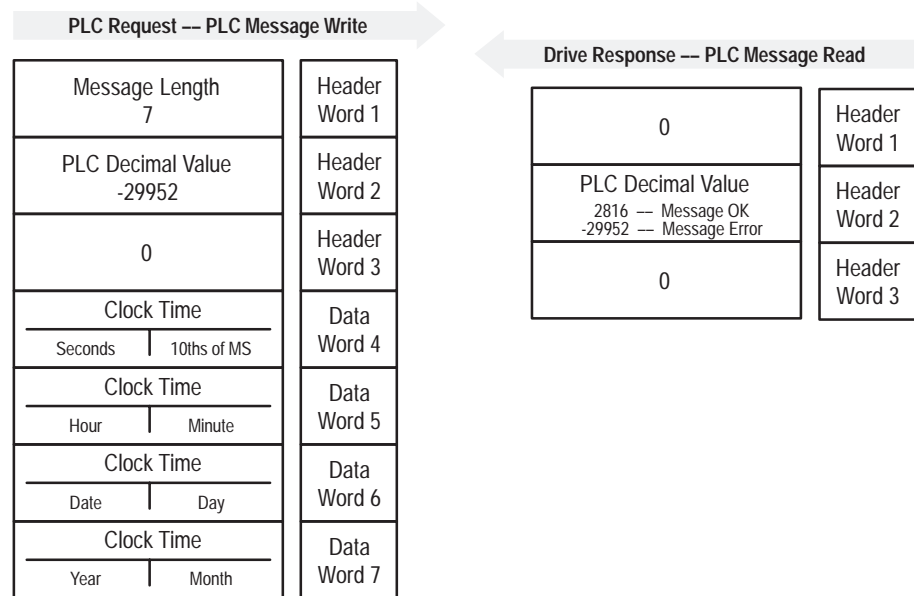

Message Operation

The Reference Time Stamp Data Write allows you to define a specific time stamp to be used in the drive.

The Time is based on a 24-hour clock.

This field:	Indicates:
Seconds	The seconds and tenths of milliseconds.
Date	The date of the month in ASCII.
Day	The day of the week, where 1 is Sunday and 7 is Saturday.
Year	The number of the year. 1990 is referenced as 0. Therefore, the year 1995 would return a value of 5.
Month	The month of the year, where 1 is January and 12 is December.

Reference Time Stamp Data
Write
(continued)

Example

This example has defined the Reference Time Stamp as Friday, February 10, 1995. The Hour of 0 indicates a starting time of 10:00 am. You can then use this information to track scheduled maintenance down times or other information as desired.

Data Format

		0	1	2	3	4	5	6	7	8	9
PLC MSG Write File	N7:10	7	-29952	0	0	0	2566	1283			
	N7:90				00\00	00\00	0A\06	05\02			
PLC MSG Read File	N7:90	0	2816	0							

ASCII Display Values

Time Stamp

Load Clock Info Reference Stamp

The Load Clock Info Reference Stamp message loads the real-time clock data into the reference stamp.

PLC Block Transfer Instruction Data

PLC Message Write instruction length: 3 words

PLC Message Read instruction length: 3 words

Message Structure

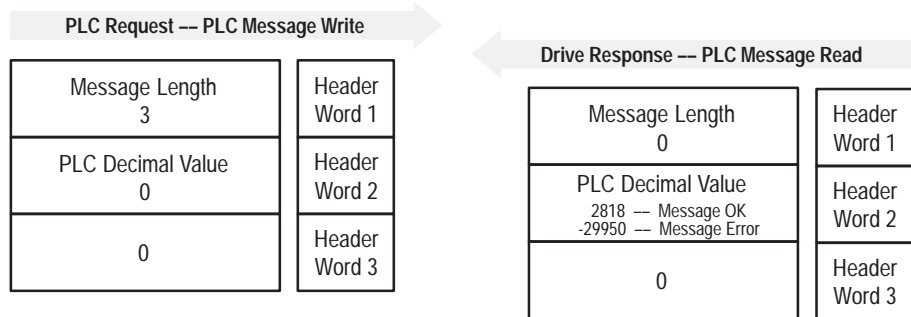

Message Operation

The Load Clock Info Reference Stamp function specified in the PMW sends the real-time clock data to the reference stamp. The reference stamp time then follows the real-time clock data.

Example

In this example, the request to load the real-time clock data into the reference stamp was sent through the PMW. The PMR responded with a message of OK.

Data Format

		0	1	2	3	4	5	6	7	8	9
PLC MSG Write File	N7:10	3	0	0							
PLC MSG Read File	N7:90	0	2818	0							

Trend File

Number of Trends Available

The Number of Trends Available function indicates how many trend files the drive supports.

PLC Block Transfer Instruction Data

PLC Message Write instruction length: 3 words

PLC Message Read instruction length: 3 words

Message Structure

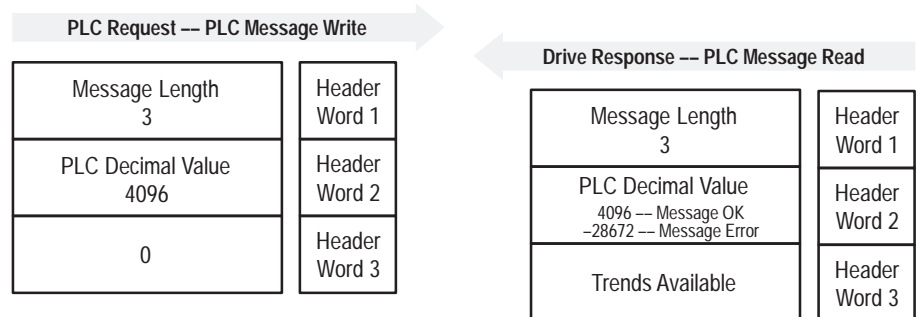

Message Operation

You can use the Number of Trends Available function to request the number of trends that the drive supports. This function always returns 4.

Example

In this example, a message was sent to the drive to request the number of trend files available. The drive response indicates that four trend files are available.

Data Format

		0	1	2	3	4	5	6	7	8	9
PLC MSG Write File	N7:10	3	4096	0							
PLC MSG Read File	N7:90	3	4096	4							

Trend File

Maximum Trend Size Available

The Maximum Trend Size Available function allows you to determine the size of the trend buffer. This function always returns 500.

PLC Block Transfer Instruction Data

PLC Message Write instruction length: 3 words
 PLC Message Read instruction length: 3 words

Message Structure

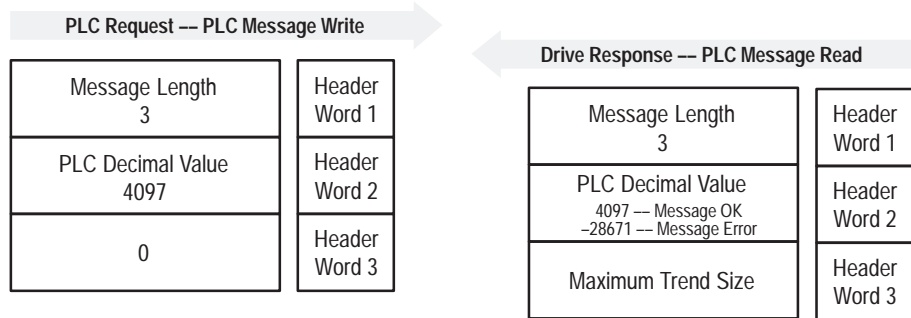

Message Operation

You can use the Maximum Trend Size Available function to determine the size of the trend buffer. This function always returns 500.

Example

In this example, a Maximum Trend Size Available request was sent to the drive. The drive returned a value of 500 in word 3.

Data Format

		0	1	2	3	4	5	6	7	8	9
PLC MSG Write File	N7:10	3	4097	0							
PLC MSG Read File	N7:90	3	4097	500							

Trend File

Trend Command

The Trend Command function allows you to send a disable trend, enable trend, or force trigger command to the drive for a specific trend operation.

PLC Block Transfer Instruction Data

PLC Message Write instruction length: 4 words
 PLC Message Read instruction length: 3 words

Message Structure

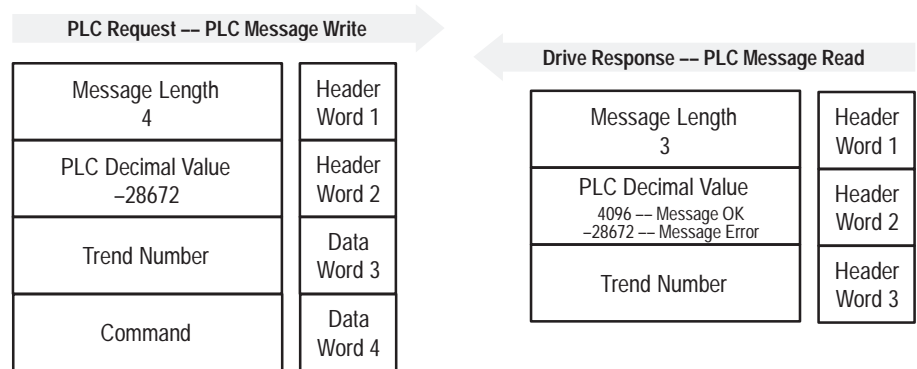

Message Operation

You can use the trend command to send one of the following commands to the drive: disable trend, enable trend, or force trigger. To send a Trend Command function, you need to specify both the trend number and the command number.

The following are the valid trend numbers:

This number:	Specifies that the command is to be sent for:
4096	Trend 1
8192	Trend 2
12228	Trend 3
16384	Trend 4

The following are the valid command numbers:

This number:	Sends a command to:
0	Disable the specified trend.
1	Enable the specified trend.
2	Force a trigger for the specified trend.

Trend Command
(continued)

Example

In this example, a disable trend command is sent for trend 4.

Data Format

		0	1	2	3	4	5	6	7	8	9
PLC MSG Write File	N7:10	4	-28672	16384	0						
PLC MSG Read File	N7:90	3	4096	0							

Trend File

Trend Status

The Trend Status function allows you to read the status of the specified trend file.

PLC Block Transfer Instruction Data

PLC Message Write instruction length: 3 words

PLC Message Read instruction length: 4 words

Message Structure

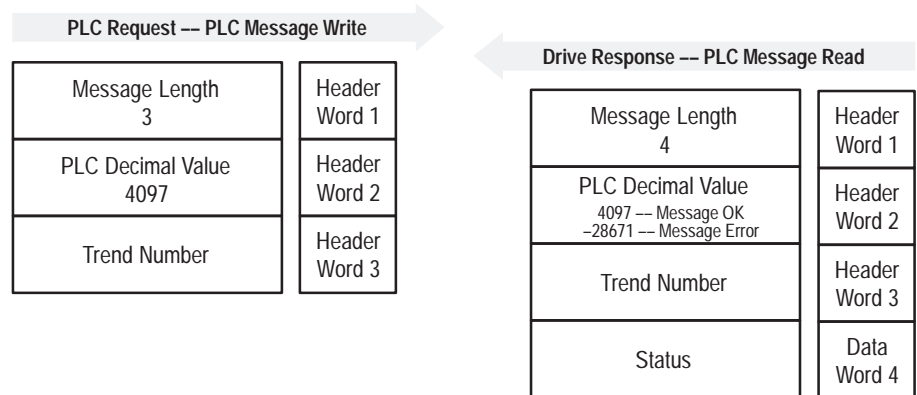

Message Operation

You can use the Trend Status function to read the status of the trend specified by Trend Number.

The following are the valid trend numbers:

This number:	Specifies that the command is to be sent for:
4096	Trend 1
8192	Trend 2
12228	Trend 3
16384	Trend 4

The following are the possible status values that can be returned in word 4:

This number:	Indicates that the trend is:
1	Stopped.
2	Running.
3	In the tripped trigger state. The condition has become true, and the post samples are being taken.
4	In the forced trigger state. The trigger condition was forced to be true so that the post samples could be taken.

Trend Status
(continued)

Example

In this example, a Trend Status message was requested for Trend 2.
The drive responded that Trend 2 is in the tripped trigger state.

Data Format

		0	1	2	3	4	5	6	7	8	9
PLC MSG Write File	N7:10	3	4097	8192							
PLC MSG Read File	N7:90	4	4097	8192	2						

Trend File

Setup Data Full

The Setup Data Full function allows you to write the trend set up information in a single message.

If the set up data write is successful, it will auto-start the trend.

PLC Block Transfer Instruction Data

PLC Message Write instruction length: 15 words

PLC Message Read instruction length: 3 words

Message Structure

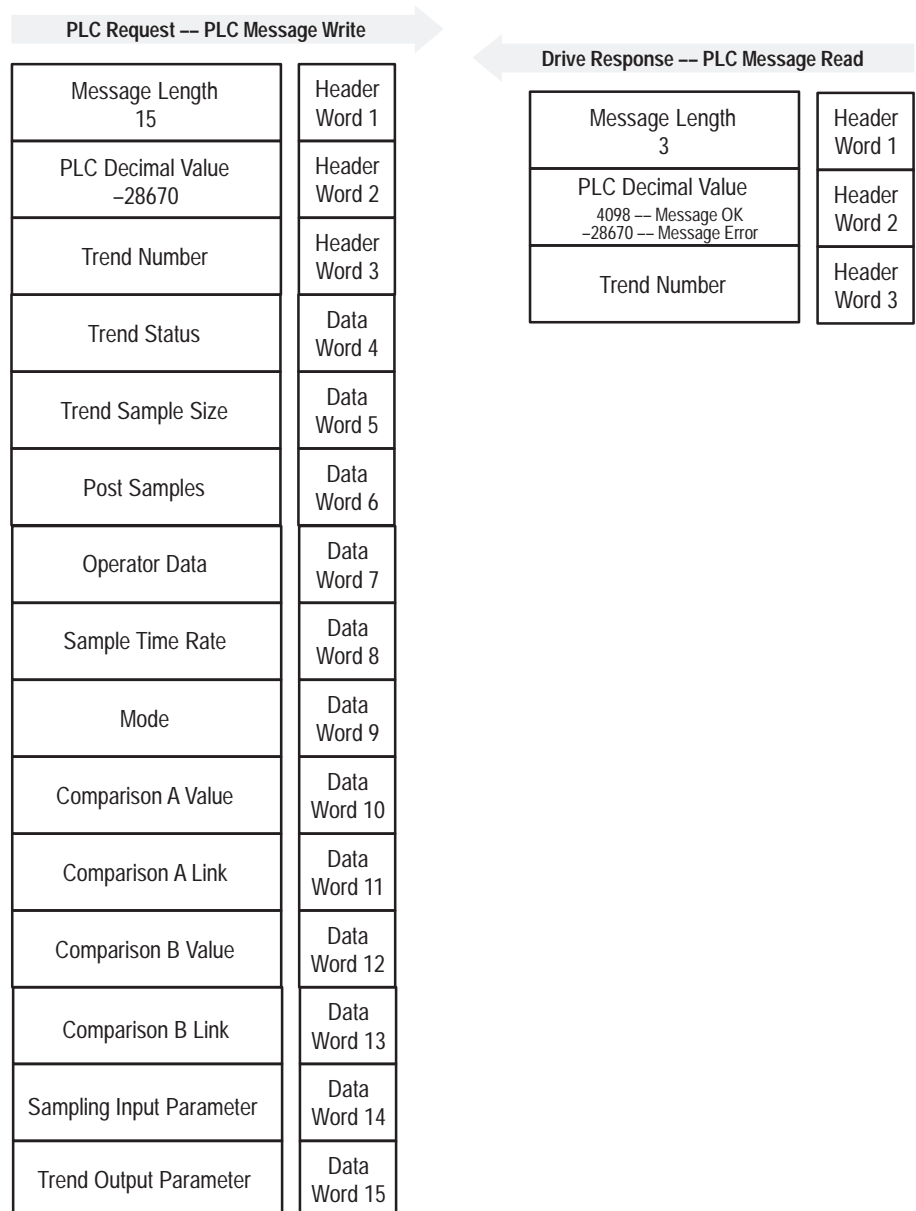

Setup Data Full (continued)

Message Operation

You can use the Setup Data Full function to load the set up information for a trend file in a single message, instead of loading the individual parameters within the drive.

The following are the valid trend numbers:

This number:	Specifies that the command is to be sent for:
4096	Trend 1
8192	Trend 2
12228	Trend 3
16384	Trend 4

Trend Status is ignored.

Trend Sample Size is ignored.

Post Samples specifies the number of samples that are taken once the trigger condition has been tripped or is forced. One sample is used for the instance when the trigger becomes true.

Operator data specifies how to compare the two data values for the trigger condition.

Sample Time Rate specifies the rate of sampling data value. An entry of 1 specifies 2 milliseconds.

Mode specifies whether a continuous trend or a one-shot trend is performed.

If Comparison A Value is non-zero, the value specifies a constant value to use as Operand X. You need to specify the Comparison A Value in internal drive units. If Comparison A Value is zero, Operand X is specified by Comparison A Link.

If Comparison A Link is non-zero, the value specifies the source parameter that is linked to the trend operand. If Comparison A Link is zero, Operand X is specified by Comparison A Value.

If Comparison B Value is non-zero, the value specifies a constant value to use as Operand Y. You need to specify the Comparison B Value in internal drive units. If Comparison B Value is zero, Operand Y is specified by Comparison B Link.

If Comparison B Link is non-zero, the value specifies the source parameter that is linked to the trend operand. If Comparison B Link is zero, Operand Y is specified by Comparison B Value.

Sampling Input Parameter specifies the source parameter number that is linked to the Trend Input parameter.

Setup Data Full
(continued)

Trend Output Parameter specifies the sink parameter number that the Trend Output parameter is linked to.

Example

In this example, a Trend 1 is set up to sample Velocity Feedback (parameter number 101). The trend triggers when Velocity Feedback is greater than 1750 rpm (an internal constant of 4096). When the trigger condition is true, 400 more samples are taken (at a rate of 12 milliseconds each) before the trend stops. The output data is then transferred to Analog Output 1 after the trend stops.

Data Format

		0	1	2	3	4	5	6	7	8	9
PLC MSG Write File	N7:10	15	-28670	4096	0	0	400	1	6	0	0
	N7:20	101	4096	0	101	387					
PLC MSG Read File	N7:90	3	4098	4096							

Trend File All Info

The All Info function allows you to read the set up information for a trend file in a single message instead of reading the individual parameters within the drive.

PLC Block Transfer Instruction Data

PLC Message Write instruction length: 3 words
 PLC Message Read instruction length: 15 words

Message Structure

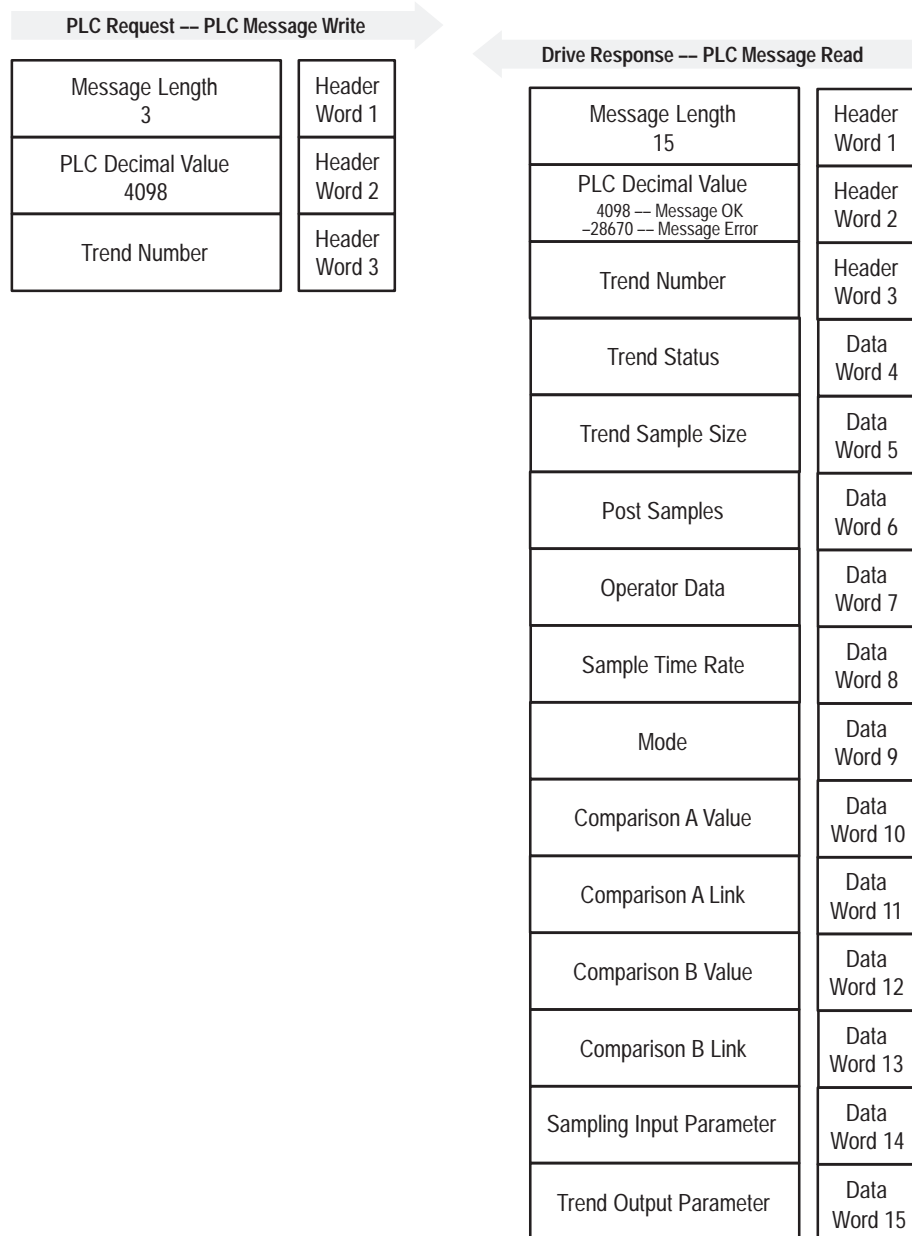

All Info
(continued)

Message Operation

You can use the All Info function to read the set up information for a trend file in one message as opposed to the individual parameters within the drive.

The following are the valid trend numbers:

This number:	Specifies that the command is to be sent for:
4096	Trend 1
8192	Trend 2
12228	Trend 3
16384	Trend 4

The following are the possible status values:

This number:	Indicates that the trend is:
1	Stopped.
2	Running.
3	In the tripped trigger state. The condition has become true, and the post samples are being taken.
4	In the forced trigger state. The trigger condition was forced to be true so that the post samples could be taken.

Trend Sample Size is always 500.

Post Samples specifies the number of samples that are taken once the trigger condition has been tripped or is forced. One sample is used for the instance when the trigger becomes true.

Operator data specifies how to compare the two data values for the trigger condition.

Sample Time Rate specifies the rate of sampling data value. An entry of 1 specifies 2 milliseconds.

Mode specifies whether a continuous trend or a one-shot trend is performed.

If Comparison A Value is non-zero, the value specifies a constant value to use as Operand X. You need to specify the Comparison A Value in internal drive units. If Comparison A Value is zero, Operand X is specified by Comparison A Link.

All Info
(continued)

If Comparison A Link is non-zero, the value specifies the source parameter that is linked to the trend operand. If Comparison A Link is zero, Operand X is specified by Comparison A Value.

If Comparison B Value is non-zero, the value specifies a constant value to use as Operand Y. You need to specify the Comparison B Value in internal drive units. If Comparison B Value is zero, Operand Y is specified by Comparison B Link.

If Comparison B Link is non-zero, the value specifies the source parameter that is linked to the trend operand. If Comparison B Link is zero, Operand Y is specified by Comparison B Value.

Sampling Input Parameter specifies the source parameter number that is linked to the Trend Input parameter.

Trend Output Parameter specifies the sink parameter number that the Trend Output parameter is linked to.

Example

In this example, the information for Trend 1 is read.

Data Format

		0	1	2	3	4	5	6	7	8	9
PLC MSG Write File	N7:10	3	4098	4096							
PLC MSG Read File	N7:90	15	4098	4096	0	500	400	1	6	0	0
	N7:100	101	4096	0	101	387					

Trend File Trigger Time

The Trigger Time function allows you to read the trigger time for the specified trend file from the drive.

PLC Block Transfer Instruction Data

PLC Message Write instruction length: 3 words

PLC Message Read instruction length: 7 words

Message Structure

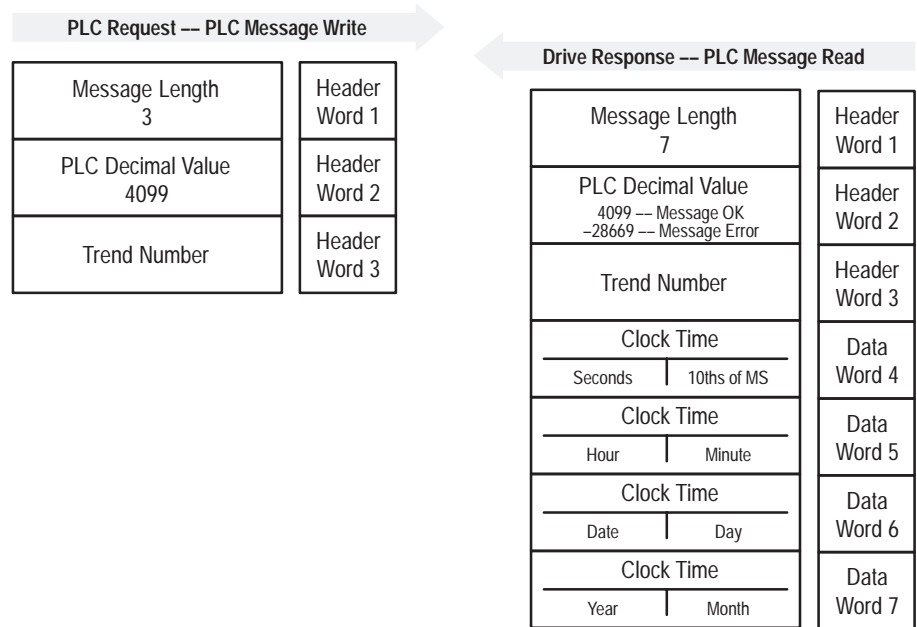

Message Operation

You can use the Trigger Time function to read the trigger time for the specified trend file from the drive.

The following are the valid trend numbers:

This number:	Specifies that the command is to be sent for:
4096	Trend 1
8192	Trend 2
12228	Trend 3
16384	Trend 4

Trigger Time
(continued)

The time is based on a 24-hour clock.

This field:	Indicates:
Seconds	The seconds (high byte) and tenths of milliseconds (low byte). The seconds can be 0 through 59, and the tenths of milliseconds can be 0 through 99.
Hour	The hour (high byte). Valid values are 0 through 23.
Minute	The number of minutes passed the hour (low byte). Valid values are 0 through 59.
Date	The date of the month (high byte). Valid values are 1 through 31.
Day	The day of the week (low byte), where 1 is Sunday and 7 is Saturday.
Year	The number of the year (high byte). 1990 is referenced as 0. Therefore, the year 1995 would return a value of 5. Valid values are 0 through 99.
Month	The month of the year (low byte), where 1 is January and 12 is December.

If the trend does not trigger and you send this request, the ControlNet Adapter Board returns the time when the drive first powered up.

Example

In this example, the trend triggered on Tuesday, October 17, 1995 at 10:49.22.74 am.

Data Format

		0	1	2	3	4	5	6	7	8	9	
PLC MSG Write File	N7:10	3	4099	4096								
PLC MSG Read File	N7:90	7	4099	4096	22	74	10	49	17	03	05	10

Trend File

Run File Data

The Run File Data function allows you to read the run-time data buffer within the drive for the specified trend file.

PLC Block Transfer Instruction Data

PLC Message Write instruction length: 3 words
 PLC Message Read instruction length: 35 words

Message Structure

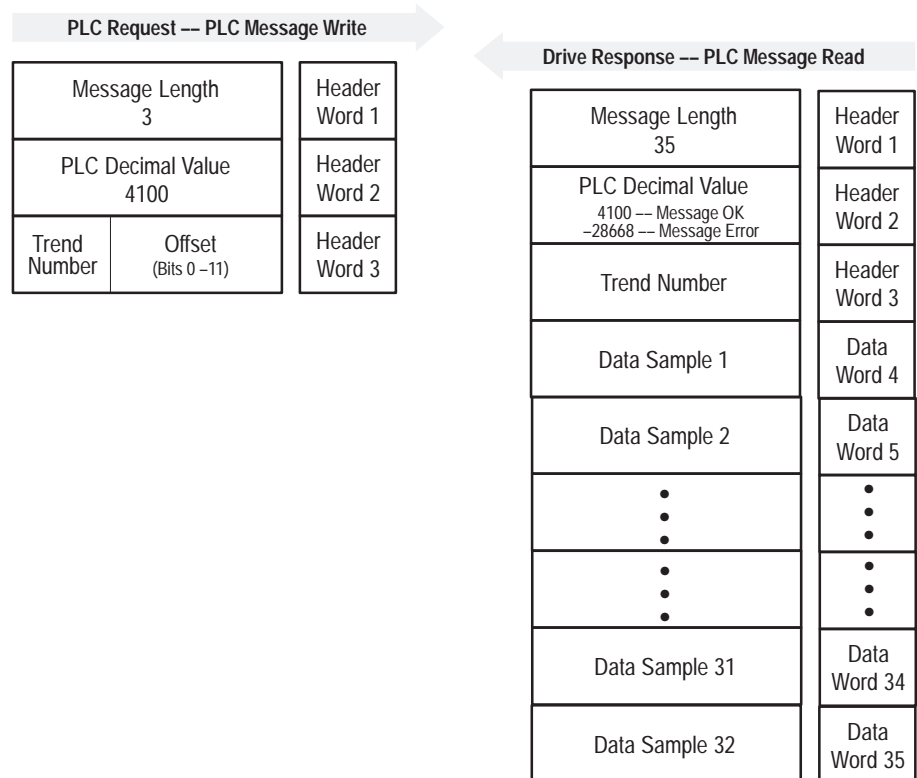

Message Operation

The Run File Data function reads the run-time buffer within the drive for the specified trend file. This buffer is continually being refreshed with new data when the trend is in the running state. Until the trend is triggered, the data is placed in the stored data file. You can use the Run File Data function to monitor data on-line. You can read 32 data samples from the data sample pointed to by the offset.

To use the Run File Data function, you need to specify the trend number in bits 12 through 15 and the offset into the buffer in bits 0 through 11 of the word 3 of the PMW. Therefore, you need to add the offset value to the trend number.

Run File Data (continued)

The following are the valid trend numbers:

This number:	Specifies that the command is to be sent for:
4096	Trend 1
8192	Trend 2
12228	Trend 3
16384	Trend 4

The offset specifies where in the buffer you want to start reading the 32 data points. For example, if you specify an offset of 64, the Run File Data function returns the 32 data samples starting from data sample 64.

If you specify an offset of zero, then the PMR message has the following format:



Run File Data
(continued)

Index indicates the index into the 500 word buffer where the last data point was written.

Timestamp is updated when the last (500th) data point is written. The time stamp has the following format:

This field:	Indicates:
Ticks	The number of ticks. One tick equals two milliseconds. Valid values are 0 through 499.
Seconds	The number of seconds. Valid values are 0 through 59.
Minute	The number of minutes past the hour. Valid values are 0 through 59.
Hour	The hour. Valid values are 0 through 23.

If you request less than 32 trend samples, then run-time data is padded with zeros. If you request data samples past the end of the buffer, then run-time data is padded with zeros.

Important: The data samples that you are reading are not being read from the trend file. Instead, the data samples are read from the running trend buffer. This buffer is continually changing at the rate specified by the sampling rate for that particular trend. You should use this function when you want to monitor the current trend sampling.

Example

In this example, Trend 1 is sampling the Velocity Feedback as it is hovering around 1750 rpm. The data is displayed in internal drive units.

Data Format

		0	1	2	3	4	5	6	7	8	9
PLC MSG Write File	N7:10	3	4100	4128							
PLC MSG Read File	N7:90	35	4100	4128	4093	4092	4093	4092	4091	4094	4093
	N7:100	4092	4091	4092	4091	4091	4092	4093	4094	4094	4093
	N7:110	4092	4091	4093	4094	4092					

Trend File Stored File Data

The Stored File Data function allows you to read the data values in the stored data file buffer when the trigger condition occurs.

PLC Block Transfer Instruction Data

PLC Message Write instruction length: 3 words
 PLC Message Read instruction length: 35 words

Message Structure

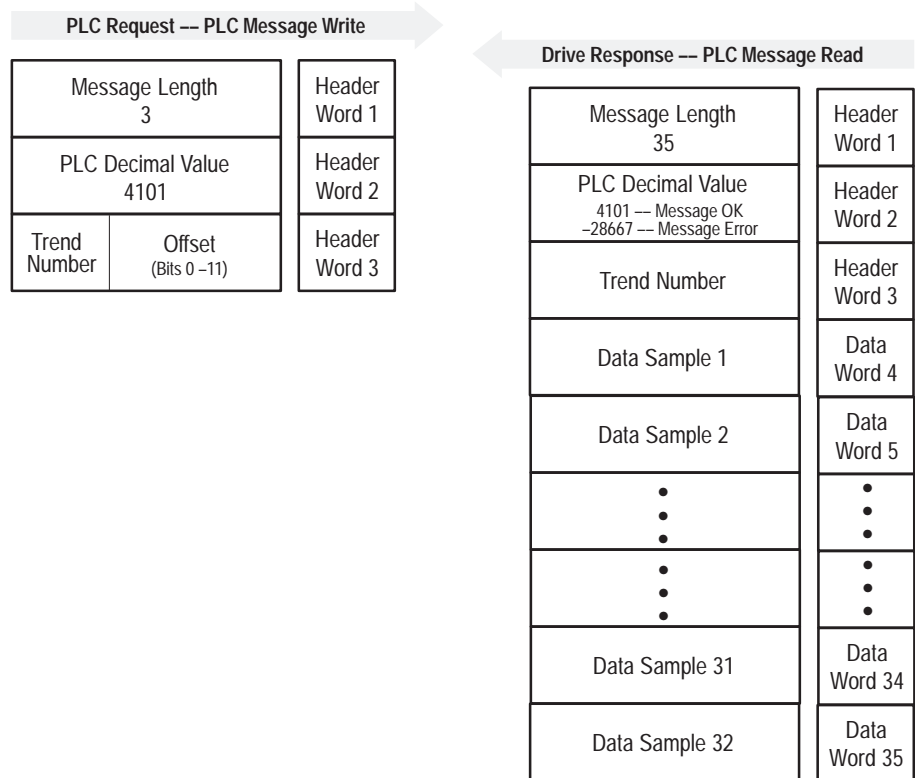

Message Operation

You can use the Stored File Data function to read the data points in the stored buffer within the drive for the specified trend file.

The following are the valid trend numbers:

This number:	Specifies that the command is to be sent for:
4096	Trend 1
8192	Trend 2
12228	Trend 3
16384	Trend 4

Stored File Data (continued)

The offset specifies where in the buffer you want to start reading the 32 data points. For example, if you specify an offset of 64, the Run File Data function returns the 32 data samples starting from data sample 64.

If you request less than 32 trend samples, then the file data is padded with zeros. If you request data samples past the end of the buffer, then the file data is padded with zeros.

This data is read from the triggered trend file. Once the buffer is filled based on the post sample number, no more data is stored and the file does not change.

Example

In this example, Trend 1 has tripped and the message request gets the data around the trigger condition.

Data Format

		0	1	2	3	4	5	6	7	8	9
PLC MSG Write File	N7:10	3	4101	4191							
PLC MSG Read File	N7:90	35	4101	4191	4092	4091	4094	4091	4097	4096	4098
	N7:100	4099	4100	4099	4101	4102	4100	4099	4098	4100	4101
	N7:100	4101	4102	4101	4099	4097	4095	4097	4100	4100	4099
	N7:110	4101	4102	4100	4099	4100					

Trend File

Trend Parameter Definition

The Trend Parameter Definition allows you to read the list of trend parameter numbers from the database.

PLC Block Transfer Instruction Data

PLC Message Write instruction length: 3 words
 PLC Message Read instruction length: 13 words

Message Structure

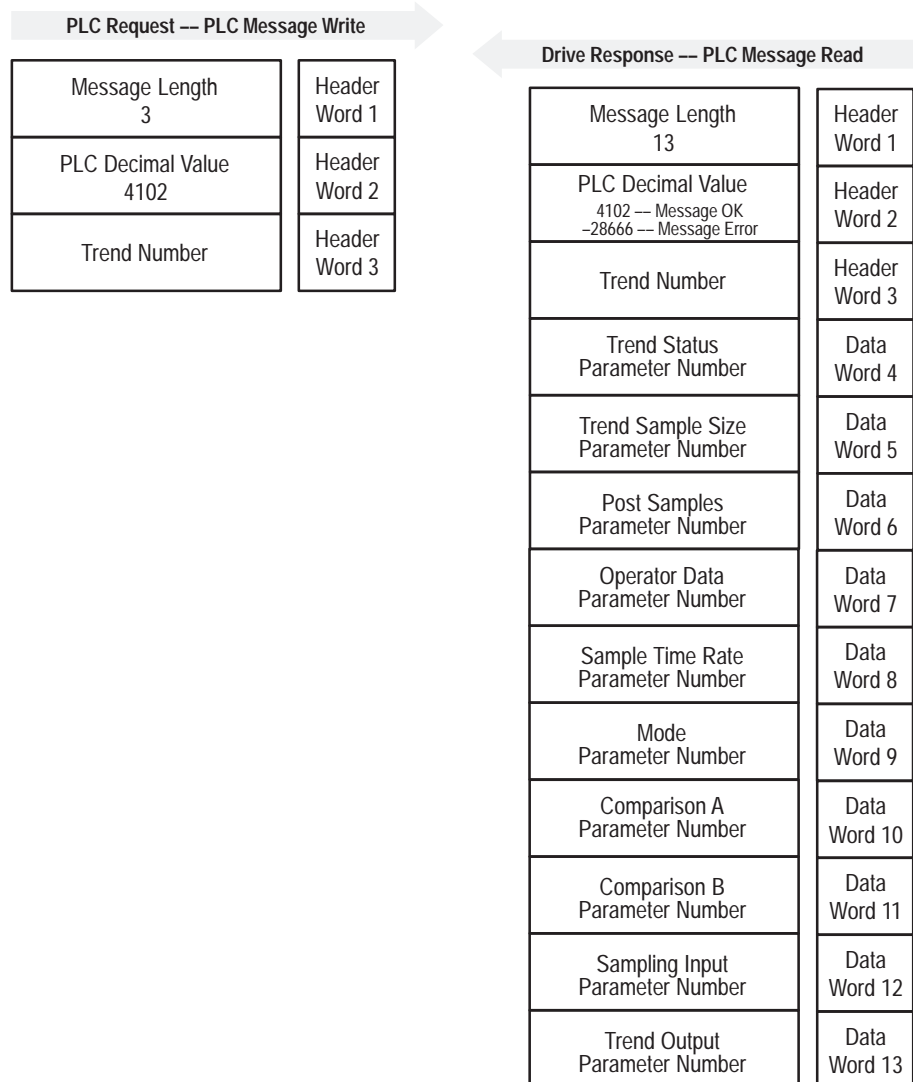

Trend Parameter Definition
(continued)

The following are the valid trend numbers:

This number:	Specifies that the command is to be sent for:
4096	Trend 1
8192	Trend 2
12228	Trend 3
16384	Trend 4

Example

In this example, the parameter numbers for Trend 3 are read.

Data Format

		0	1	2	3	4	5	6	7	8	9
PLC MSG Write File	N7:10	3	4102	12228							
PLC MSG Read File	N7:90	13	4102	12228	482	453	479	477	478	480	475
	N7:100	476	474	483							

Trend File

Trend Triggered Setup Parameter Values

The Trend Triggered Setup Parameter Values function allows you to read the trend set up data for the stored data file.

PLC Block Transfer Instruction Data

PLC Message Write instruction length: 3 words
 PLC Message Read instruction length: 16 words

Message Structure

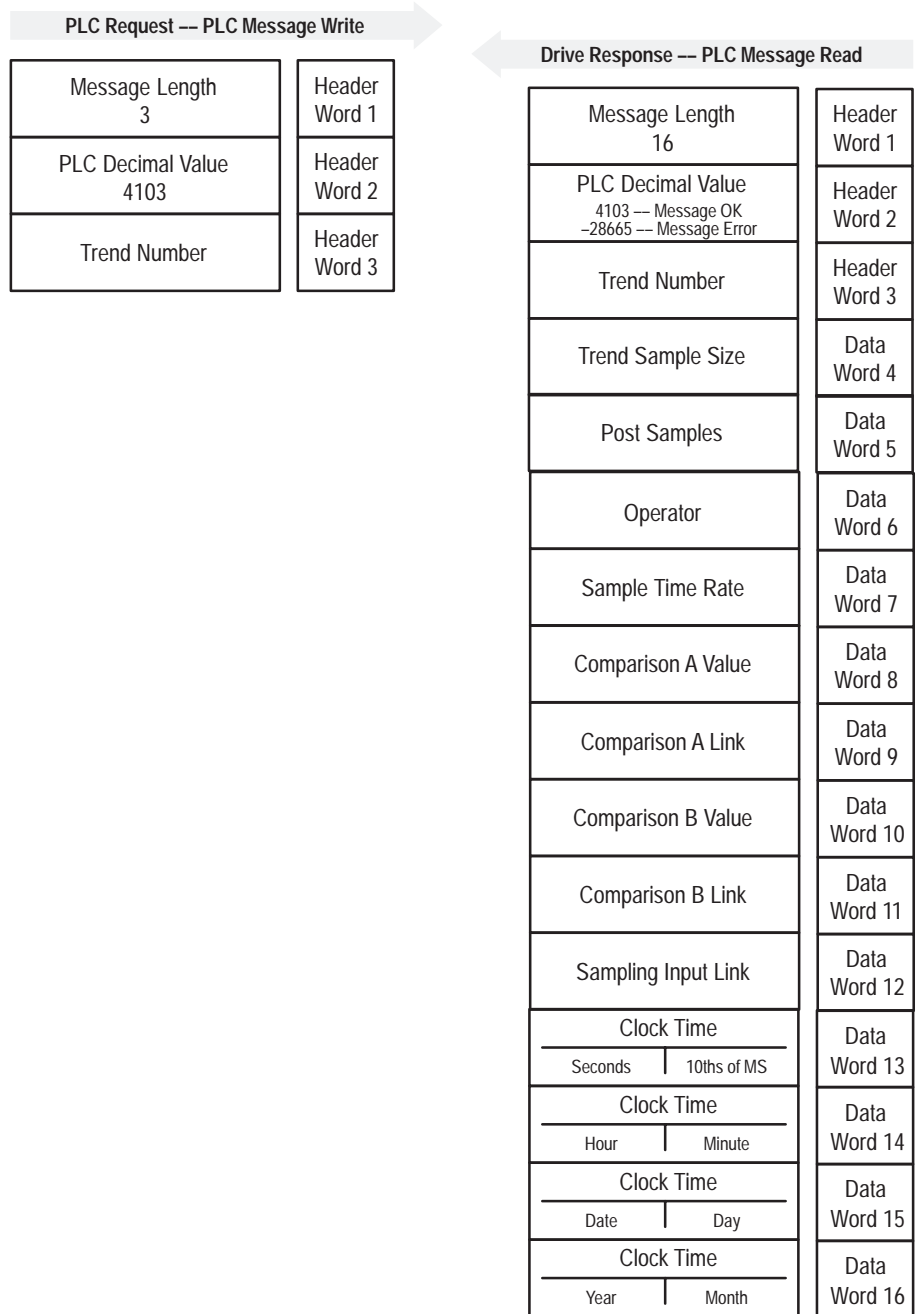

Trend Triggered Setup Parameter Values
(continued)

Message Operation

You can use the Trend Triggered Setup Parameter Values function to read the list of trend set up data for the stored data file.

The following are the valid trend numbers:

This number:	Specifies that the command is to be sent for:
4096	Trend 1
8192	Trend 2
12228	Trend 3
16384	Trend 4

The time is based on a 24-hour clock.

This field:	Indicates:
Seconds	The seconds (high byte) and tenths of milliseconds (low byte). The seconds can be between 0 and 59, and the milliseconds can be between 0 and 99.
Minute	The number of minutes past the hour (low byte). Valid values are 0 through 59.
Hour	The hour (high byte). Valid values are 0 through 23.
Date	The date of the month (high byte). Valid values are 1 through 31.
Day	The day of the week (low byte), where 1 is Sunday and 7 is Saturday.
Year	The number of the year (high byte). 1990 is referenced as 0. Therefore, the year 1995 would return a value of 5. Valid values are 0 through 99.
Month	The month of the year (low byte), where 1 is January and 12 is December.

Trend Triggered Setup Parameter Values
(continued)

Example

In this example, velocity feedback exceeds 1750 rpm (4096 in internal units) on October 17, 1995 at 2:28.33.17 pm.

Data Format

		0	1	2	3	4	5	6	7	8	9
PLC MSG Write File	N7:10	3	4103	4096							
PLC MSG Read File	N7:90	16	4103	4096	500	400	1	6	0	101	4096
	N7:100	0	101	33 17	28 14	03 17	10 05				

This Page Intentionally Blank

Understanding the Resources of Your Drive

Chapter Objectives

Chapter 5 provides information about using the resources that are available with your drive. The following topics are covered in this chapter:

- understanding the SCANport logic control and operation
- understanding function blocks
- using system resources

Using the SCANport Capabilities

You can make some changes to the default configuration to customize the way SCANport works for you. This section covers the following topics:

- understanding the logic command parameter
- configuring the SCANport controls
- setting the loss of communications fault
- viewing the SCANport faults and warnings
- using the SCANport image
- setting the analog I/O parameters

Understanding the Logic Command Parameter

The Logic Command parameter (parameter 52) on the 1336 FORCE is modified by receiving input from ChA Logic Cmd In, and SCANport devices 1 through 5 on the ControlNet Adapter Board. To use these parameters effectively, you need to understand how the Logic Command parameter works.

The Logic Command provides information about what functions are currently executing. You can access the individual bits of the Logic Command to find information about these functions:

This bit:	Identifies this function:	This bit:	Identifies this function:
0	Ramp Stop	8	Coast Stop
1	Start	9	Ramp Disable
2	Jog1	10	Flux Enable
3	Clear Fault	11	Process Trim Enable
4	Forward	12	Velocity Ref Select A
5	Reverse	13	Velocity Ref Select B
6	Jog2	14	Velocity Ref Select C
7	Current Limit Stop	15	Reset Drive

You cannot change the values shown in the Logic Command by directly accessing the parameter. Instead, the Logic Command receives information from the logic evaluation block.

The logic evaluation block can receive information from up to seven sources. The logic evaluation block takes this information and combines it to form a single logic command word:

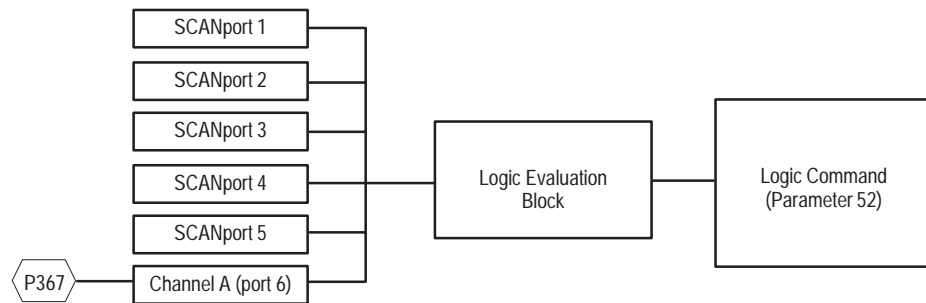

In this figure, notice that there are five SCANports and one channel that can provide information to the logic evaluation block. You can attach any combination of Human Interface Modules (HIMs), Graphic Programming Terminals (GPTs), and/or SCANport communications modules to any of the five SCANports.



Note: SCANports 1 and 2 are always available directly from the ControlNet Adapter Board. To access SCANports 3, 4, and 5, you need to attach a SCANport Expansion Board to your ControlNet Adapter Board.

The channel is accessed through parameter 367 (ChA Logic Cmd In). This parameter has the same bit definitions as the Logic Command.

Important: In the PLC controller, internal bit numbering is 0 through 15 decimal and I/O bit numbering is 0 through 17 octal. However, bit numbering in the drive parameters, including ChA Logic Cmd In, is 0 through 15 decimal. You should keep this in mind when working with the Logic Command.

For example, if you want to set the Ramp Disable bit in the Logic Command (bit 9 decimal), you would need to set bit 11 (octal) in your PLC program.

If you select the external speed reference, the PLC controller must send a 16-bit word to parameter 101, Velocity Reference 1 HI, in the drive. Because the speed reference is a complete 16-bit word, the PLC controller must send the data as a complete word rather than as individual bits as was the case for logic command bits.

The following figure shows the correlation between the output image table bits and the bits used by the Logic Command.

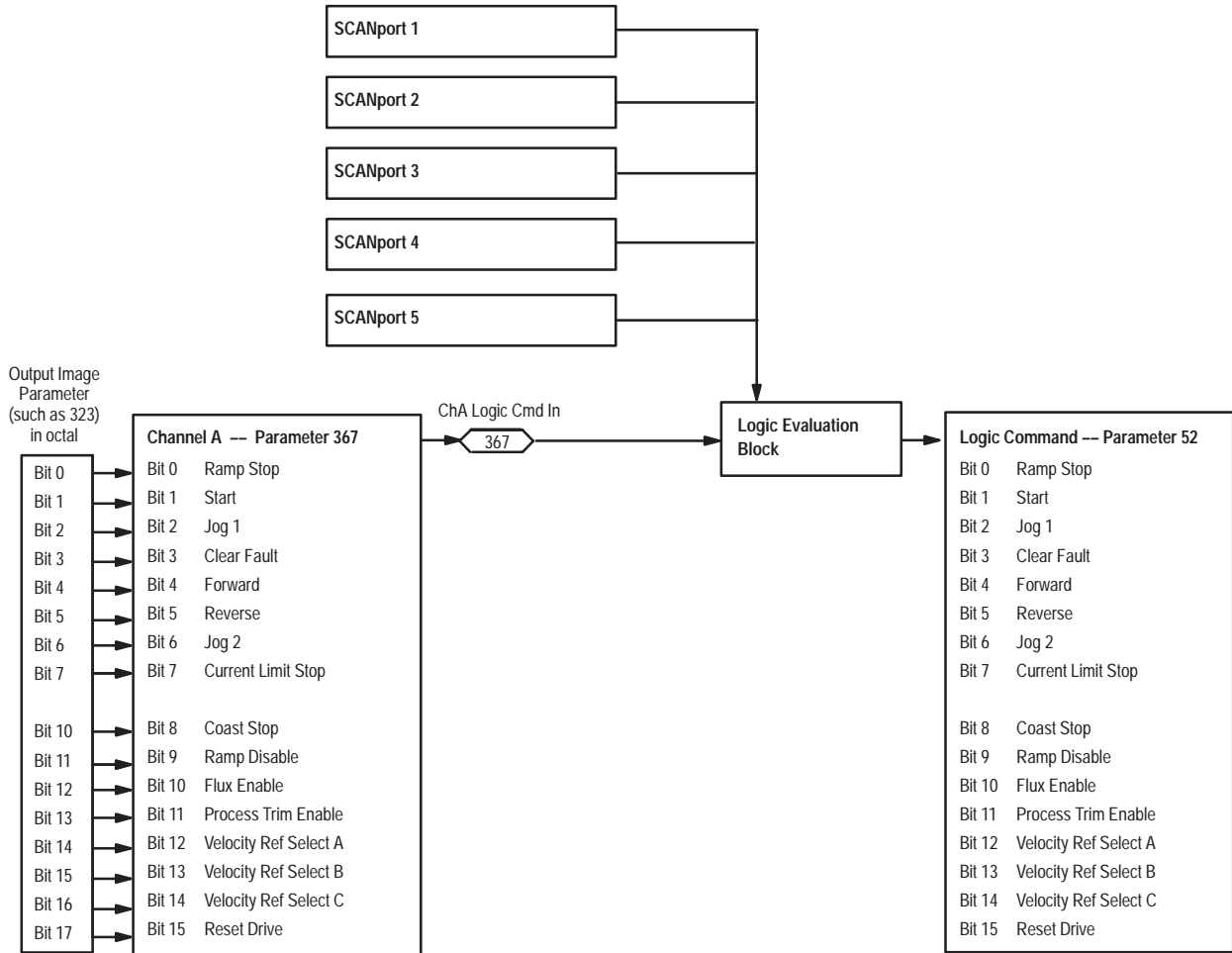

This next figure shows the parameter interactions involved with the Logic Command.

SCANport Logic Command Configuration Masks

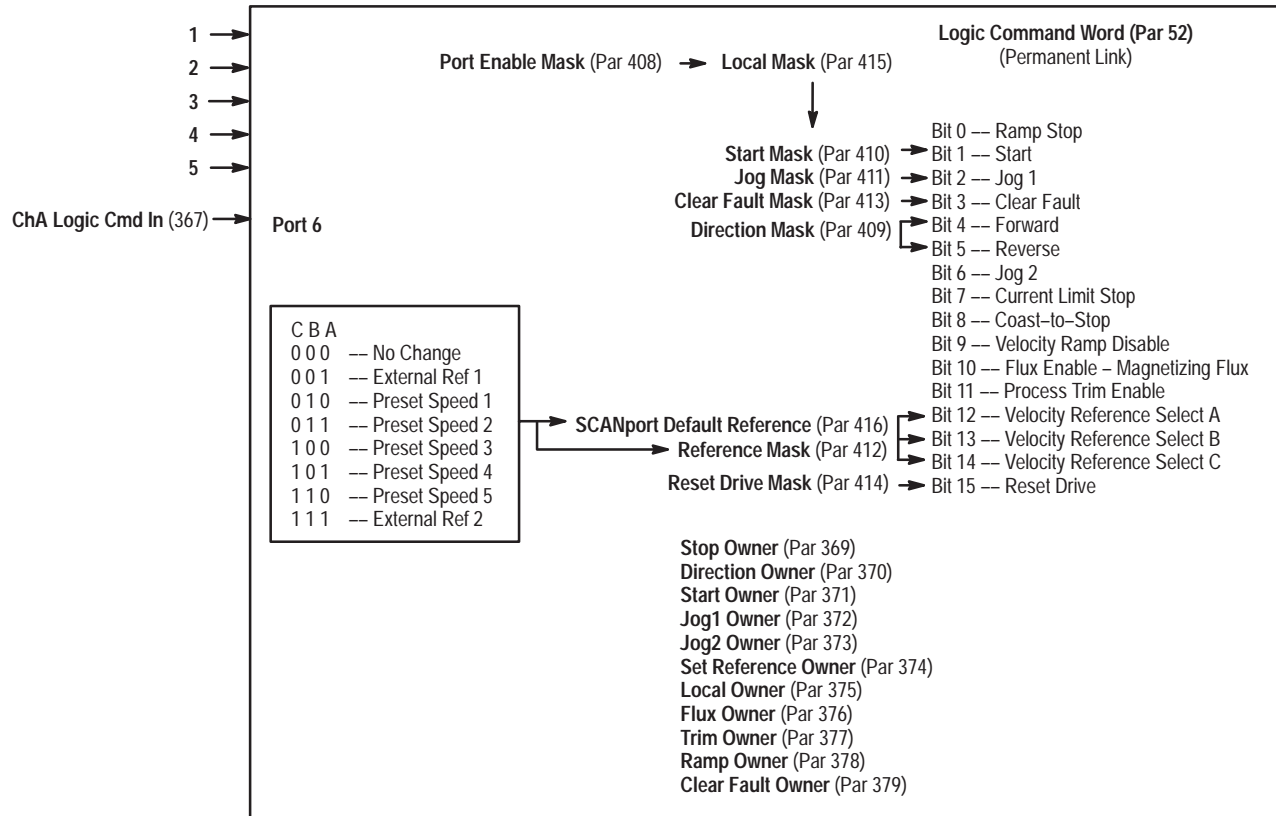

The owner parameters (369 through 379) are covered in the next section.

Configuring the SCANport Controls

The SCANport controls are the functions that control the motor, such as start, stop, and jog. The control can come from up to five SCANport devices and one parameter (367) at the same time. The control is based on an ownership mechanism that allows certain functions to only have one owner and other functions to have multiple owners. Speed reference, direction, and local functions are the only one owner functions. The other functions, such as start, stop, and jog, are considered multiple owner functions.

- **Note:** When you apply power to the system, the default input speed reference is specified in SP Default Ref (parameter 416). You can change the value of SP Default Ref at any time, but the change does not take effect until the power is cycled. SP Default Ref may be set to external reference 1 or 2 or preset speeds 1, 2, 3, 4, or 5.

To correctly cycle power, follow this sequence:

1. Remove power to the drive at the disconnect.
2. Let the bus voltage decay completely.
3. Restore power to drive.

Ownership is when a SCANport device commands a function. As long as that function is commanded, that device is the owner of that function. For example, if device 1 is commanding a forward direction, which is a one owner function, no other device can change the direction until device 1 stops commanding the forward direction. If device 1 is commanding a start, which is a multiple owner function, other devices can also command a start. If device 1 stops commanding the start, the drive does not stop running if another device is still commanding the start.

- **Note:** A rising edge is required for start and jog functions. If a jog or start is still commanded after the drive is stopped, start and jog functions will not operate from any device until the jog or start commands are removed.

Determining Function Ownership

To determine which device is issuing a specific command, you can use parameters 369 through 379:

To determine which device is issuing this command:	Check this parameter:
Stop	369
Direction control	370
Start	371
Jog1	372
Jog2	373
Velocity reference	374
Local control	375
Flux enable	376
Trim enable	377
Ramp	378
Clear fault	379

For each of these parameters, each bit represents a device:

If this bit is set:	Then, the owner is:
1	SCANport device 1
2	SCANport device 2
3	SCANport device 3
4	SCANport device 4
5	SCANport device 5
6	ChA Logic Cmd In



NOTE: Bit 0 is not used. Also, the SCANport device number is determined by the SCANport connection it is plugged into.

Masking Control Functions

You can also mask control functions. This allows you to enable or disable a control function for all or some of the devices.

Important: You cannot mask the stop command. Any device attached to the ControlNet Adapter Board can stop the drive at any time.

To set a mask for a control function, you can use the following parameters:

To set a mask to control this function:	Use this parameter:
Control which ports can accept the control functions	408
Issue forward/reverse commands	409
Issue a start command	410
Issue a jog command	411
Select an alternate reference or preset speed	412
Generate a clear fault command	413
Reset faults	414
Allow exclusive control of logic commands	415

For each of these parameters, each bit represents a device:

This bit:	Represents:
1	SCANport device 1
2	SCANport device 2
3	SCANport device 3
4	SCANport device 4
5	SCANport device 5
6	ChA Logic Cmd In



NOTE: Bit 0 is not used. Also, the SCANport device number is determined by the SCANport connection it is plugged into.

If a bit is set to 0 for a mask parameter, the control function is disabled. If a bit is set to 1, the control function is enabled.

There are three levels of masking control functions:



The Port Enable mask can enable or disable all of the device's control functions. If the Port Enable mask is set to enable the control functions, the control is passed to the Local Mask. The Local Mask can allow a device to take full control of a drive. If the device does not have full control, then the individual masks can take effect.

Setting the Loss of Communications Fault

You can specify how you want to be notified if SCANport loses the connection to a port.

If you want a communications loss to be:	Then:
Reported as a fault*	Set the appropriate bit in parameter 440 corresponding to the SCANport.
Reported as a warning*	Set the appropriate bit in parameter 441 and do not set (clear) the bit in parameter 440.
Ignored*	Do not set (clear) the appropriate bit in either parameter 440 or 441.

* By default communications loss is reported as both a fault and a warning.

The following table shows you which bits correspond to which ports:

This bit:	Represents:
1	SCANport device 1
2	SCANport device 2
3	SCANport device 3
4	SCANport device 4
5	SCANport device 5

For example, if you want a fault condition to be reported if communication is lost with device 3, you would set bit 3 of parameter 440.



ATTENTION: If you initiate a command to start motor rotation (command a start or jog) and then disconnect the programming device, the drive will not fault if you have the SCANport communications fault set to be ignored for that port.

Viewing the SCANport Fault Status

If a fault occurs while using SCANport, you can use parameters 442 and 443 to determine the port at which the fault was encountered. Use parameter 442, SP Fault Sts, to view the fault status and parameter 443, SP Warn Sts, to view the warning status. For either parameter, you can use the following table to determine where the problem was encountered:

This bit:	Represents:
1	SCANport device 1
2	SCANport device 2
3	SCANport device 3
4	SCANport device 4
5	SCANport device 5

Using the SCANport Image

The SCANport image is a mechanism for transferring data between SCANport devices and the drive. The SCANport image is used in transferring real-time data in the same way as the PLC image is used. The devices on SCANport allocate the SCANport image so multiple devices can use different parts of the image. The image can only be used in a full rack. This allows a maximum of four devices to access the drive at the same time.

You can view the values in the SCANport image table by using parameters 314 through 321 for input and 343 through 350 for output:

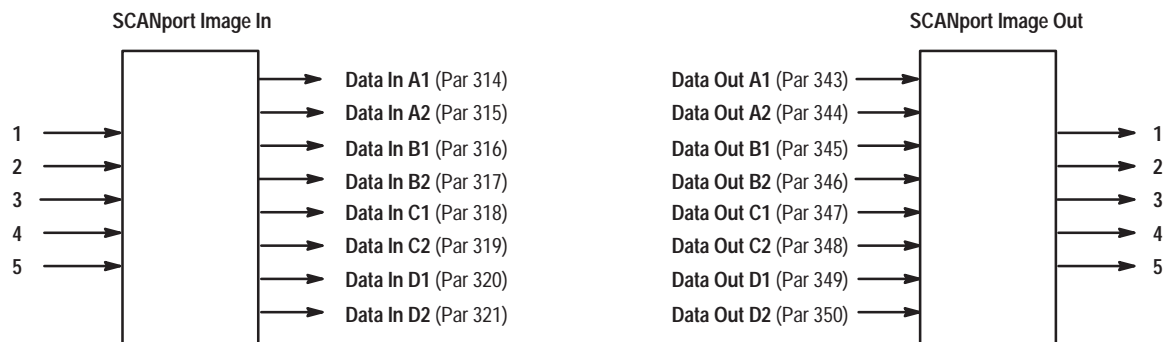

The RS232/485 to SCANport, and DeviceNet to SCANport gateways are some of the devices that use the image.



Refer to the appropriate manual for your gateway (Bulletin 1203 Serial Communications Module, or the DeviceNet Communications Module manual).

Setting Up the Analog I/O Parameters

The ControlNet Adapter Board can transfer analog information over SCANport.

The following figure shows the five SCANports that are available for use with the SCANport analog I/O and the ControlNet Adapter Board parameters that you can use to control this data.

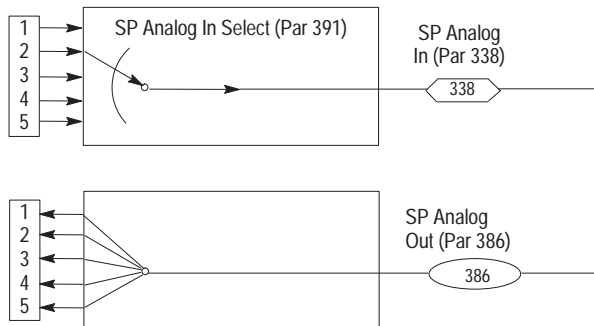

To receive analog input from a SCANport device, you need to:

1. Set the SCANport Analog Input Select parameter (parameter 391) to the SCANport device number.
2. Link a sink parameter to the SCANport Analog Input parameter (parameter 338).

For example, if you plug a HIM into port 1 to control the external velocity, you need to enter a value of 1 for SCANport Analog Input Select (parameter 391) and link External Velocity (parameter 101) to SCANport Analog Input (parameter 338). You may scale the velocity by using External Velocity Scale (parameter 102).

The drive sends SCANport Analog Output (parameter 386) to all devices connected to SCANport. To send data out to the SCANport devices, you must link SCANport Analog Output to a source parameter. For example, if the HIM is to receive Velocity Feedback, you would link SCANport Analog Output (parameter 386) to Velocity Feedback (parameter 269).

Understanding Function Blocks

At times, you may want to customize the way your drive operates. To help you with this task, function blocks have been included with the ControlNet Adapter Board. You can combine function blocks together to operate on almost any part of the drive functionality. The flexibility of the function block system allows blocks to be used with the drive's velocity or current control parameters, drive-to-drive parameters, as well as analog image parameters.

Important: This section is intended to be an overview of the function block system. For more in-depth information, refer to the Function Block Programming Manual.

The function block software provides the following advantages:

- On smaller stand-alone applications, control programming can be carried out completely within the drive.
- On larger system applications, the loading of the PLC control system can be reduced as control functions previously performed within a PLC can be performed within the drive.

At the base of the function block system are the function blocks themselves. A function block is a firmware subroutine that is stored in memory within the ControlNet Adapter Board. The ControlNet Adapter Board provides 28 different function block types.

These function blocks are as follows:

This function type:	Is:
ABS	An absolute value function block whose output is the positive value.
BIN2DEC	A binary to decimal function block that takes sixteen input words and produces one decimal output word.
COMPHYST	A compare with hysteresis function block that checks for input equals preset value with a hysteresis around the value.
DEC2BIN	A decimal to binary function block that takes one decimal input word and produces sixteen binary output words.
DELAY	A time delay function block that echoes a logic input after a delay.
DERIV	A derivative function block that calculates the change in input per second.
DIVIDE	A divide function block that divides two signed integers.
EXOR2	An exclusive OR function that takes two inputs and provides two output values, the XOR of those values and the NOT of the output value.
FILTER	A first order low pass algorithm filter, with a programmable bandwidth in tenths of radians per second.
4AND	An AND function that takes four inputs and performs a logical AND.
4OR	An OR function that takes the logical OR of four inputs.
FUNCTION	A function that takes a user approximation for a function and linearly interpolates between two of five possible points.
INTEGRATOR	An integrator function block that does trapezoidal integration.
LIMIT	A limiter function block that limits an input to programmed minimum and maximum values.
LNOT	A logical NOT function.
MINMAX	A minimum or maximum function block that you can program to take the minimum or maximum of two input values.
MONOSTABLE	A one shot monostable function block that elongates a rising edge signal for a specified time duration.
MULTIPLEXER	A select function block that multiplexes one of four inputs based on the state of the selector inputs.
MULTIPLY	A multiply function block that multiplies two signed integers.
NO-OP	A PLC space holder.
PI CTRL	A proportional/integral control function block that takes the difference between two inputs and performs a PI control with a proportional and integral gains.
PULSE CNTR	A pulse counter function block that counts rising edges of an input value.
RATE LIMITER	A ramp function block that limits the rate of change of an input value.
SCALE	A scale function block that uses the following formula: $IN1 \times (MULTI/DIV)$.
SR FF	A set-reset flip-flop.
SUB	A subtract function block that subtracts two signed numbers.
T-FF	A toggle flip flop function block that changes the state of the input.
2ADD	An add function block that adds two signed numbers.
UP/DWN CNTR	An up/down counter function block that increments or decrements to a specified value in a specified amount of time.

In addition, each function block type also has parameters that are called I/O nodes associated with them. When you use a function block, the I/O nodes are created within the system. These I/O nodes are removed from the system when that function block is no longer in use. In all, the function block software can allow a total of 799 new node parameters in addition to the 493 linear parameters. You can modify and manipulate the node parameters to meet the needs of your particular application.

Using the function block node parameters requires that you create a function block application. A function block application is a combination of the function blocks that you want the drive to execute in the order that you want them executed. Each function block within an application is called an event, and you may have up to 128 events in your application. To create your application, you need to use a PC with the DriveTools' DriveBlockEditor software, a Bulletin 1201 Graphic Programming Terminal (GPT), or a PLC.

Once you have created your function block application, you need to download it to the drive where it is compiled into a function block program. When you download and compile the application, the ControlNet Adapter Board creates the functionality and data sets within the drive. Once the application is running, each event is executed with a 20 millisecond task interval.



Note: You can only have one function block application executing in the drive at any given time.

Using System Resources

The following figure shows an example of a 1336 FORCE drive with a ControlNet Adapter Board. A function block control application is also used.

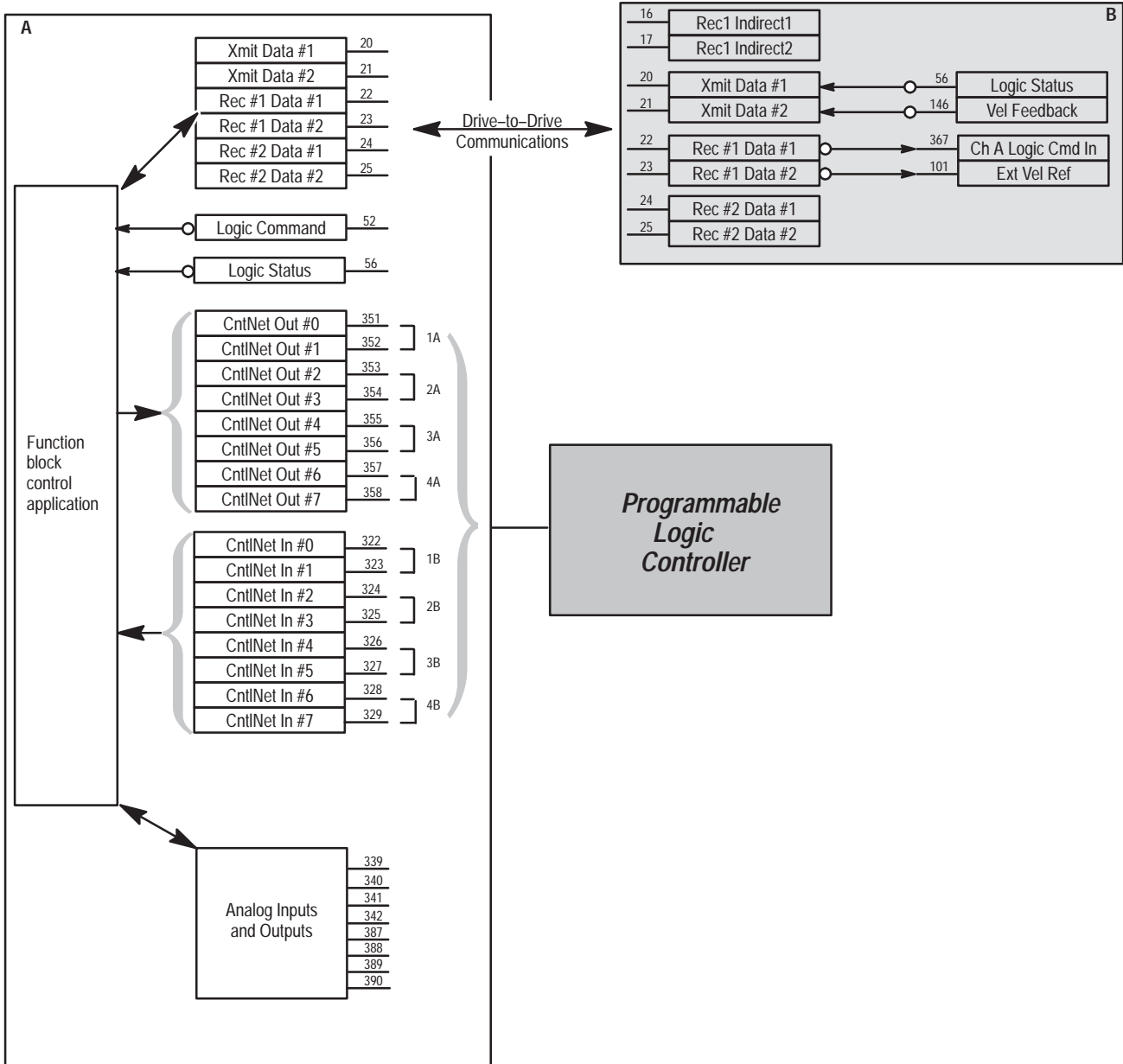

In the previous figure:

- Drive B is connected to Drive A using Drive-to-Drive communications via a DeviceNet cable. You can use Drive-to-Drive communications to connect any FORCE drive with a Standard Adapter, a PLC Comm Adapter Board or a ControlNet Adapter Board.

This Page Intentionally Blank

Parameters

Chapter Objectives

Chapter 6 provides information about the following:

- BRAM functions
- parameter definitions

BRAM Functions

BRAM, or Battery backed up Random Access Memory (also known as EEPROM), is memory that is retained when the power is removed from the system. User parameters, link fault information, reference stamp, process display information, and passwords are all stored in BRAM. The three available BRAM functions are:

- **BRAM Store**

Stores current parameter value and links to BRAM.



Note: BRAM Jumper J3 must have a jumper on EN (enable) to store data to BRAM.

- **BRAM Recall**

Updates the current values and links with parameter values and links stored in BRAM.

- **BRAM Initialize**

Writes the factory set default values and links to RAM.

Parameter Listing

The following table lists the parameters in numerical order.

No.	Name	Group	Page	No.	Name	Group	Page
300	Adapter ID	1 -- Adapter Info	6-12	344	Data Out A2	3 -- SCANport I/O	6-19
301	Adapter Version	1 -- Adapter Info	6-12	345	Data Out B1	3 -- SCANport I/O	6-19
302	SP Comm Retries	1 -- Adapter Info	6-12	346	Data Out B2	3 -- SCANport I/O	6-19
303	ChA DIP Switch	7 -- Channel A	6-12	347	Data Out C1	3 -- SCANport I/O	6-19
304	*			348	Data Out C2	3 -- SCANport I/O	6-19
305	ChA LED State	7 -- Channel A	6-12	349	Data Out D1	3 -- SCANport I/O	6-20
306	*			350	Data Out D2	3 -- SCANport I/O	6-20
307	ICN Status	1 -- Adapter Info	6-13	351	Cntl Net Out 0	7 -- Channel A	6-20
309	Language Sel	1 -- Adapter Info	6-13	352	Cntl Net Out 1	7 -- Channel A	6-20
314	Data In A1	3 -- SCANport I/O	6-13	353	Cntl Net Out 2	7 -- Channel A	6-21
315	Data In A2	3 -- SCANport I/O	6-13	354	Cntl Net Out 3	7 -- Channel A	6-21
316	Data In B1	3 -- SCANport I/O	6-13	355	Cntl Net Out 4	7 -- Channel A	6-21
317	Data In B2	3 -- SCANport I/O	6-14	356	Cntl Net Out 5	7 -- Channel A	6-22
318	Data In C1	3 -- SCANport I/O	6-14	357	Cntl Net Out 6	7 -- Channel A	6-22
319	Data In C2	3 -- SCANport I/O	6-14	358	Cntl Net Out 7	7 -- Channel A	6-22
320	Data In D1	3 -- SCANport I/O	6-14	359	*		
321	Data In D2	3 -- SCANport I/O	6-14	360	*		
322	Cntl Net In 0	7 -- Channel A	6-15	361	*		
323	Cntl Net In 1	7 -- Channel A	6-15	362	*		
324	Cntl Net In 2	7 -- Channel A	6-15	363	*		
325	Cntl Net In 3	7 -- Channel A	6-16	364	*		
326	Cntl Net In 4	7 -- Channel A	6-16	365	*		
327	Cntl Net In 5	7 -- Channel A	6-16	366	*		
328	Cntl Net In 6	7 -- Channel A	6-17	367	ChA Logic Cmd In	3 -- SCANport I/O	6-23
329	Cntl Net In 7	7 -- Channel A	6-17	368	*		
330	*			369	Stop Owner	5 -- Owners	6-23
331	*			370	Dir Owner	5 -- Owners	6-23
332	*			371	Start Owner	5 -- Owners	6-24
333	*			372	Jog 1 Owner	5 -- Owners	6-24
334	*			373	Jog 2 Owner	5 -- Owners	6-24
335	*			374	Set Ref Owner	5 -- Owners	6-25
336	*			375	Local Owner	5 -- Owners	6-25
337	*			376	Flux Owner	5 -- Owners	6-25
338	SP Analog In	3 -- SCANport I/O	6-17	377	Trim Owner	5 -- Owners	6-25
339	Analog In 1	6 -- Analog I/O	6-18	378	Ramp Owner	5 -- Owners	6-25
340	Analog In 2	6 -- Analog I/O	6-18	379	Clr Fault Owner	5 -- Owners	6-25
341	Analog In 3	6 -- Analog I/O	6-18	386	SP Analog Out	3 -- SCANport I/O	6-25
342	Analog In 4	6 -- Analog I/O	6-18	387	Analog Out 1	6 -- Analog I/O	6-26
343	Data Out A1	3 -- SCANport I/O	6-19	388	Analog Out 2	6 -- Analog I/O	6-26

* Not Used in this application

No.	Name	Group	Page	No.	Name	Group	Page
389	Analog Out 3	6 -- Analog I/O	6-26	443	SP Warn Sts	2 -- Adapter Diagnostics	6-36
390	Analog Out 4	6 -- Analog I/O	6-26	454	Trend In 1	9 -- Trend I/O	6-36
391	SP Analog Sel	3 -- SCANport I/O	6-26	455	Tr1 Opnd Parm X	9 -- Trend Setup	6-36
392	An In 1 Offset	6 -- Analog I/O	6-27	456	Tr1 Opnd Parm Y	9 -- Trend Setup	6-37
393	An In 1 Scale	6 -- Analog I/O	6-27	457	Tr1 Operator	9 -- Trend Setup	6-37
394	An In 2 Offset	6 -- Analog I/O	6-27	458	Tr1 Sample Rate	9 -- Trend Setup	6-37
395	An In 2 Scale	6 -- Analog I/O	6-27	459	Tr1 Post Samples	9 -- Trend Setup	6-37
396	An In 3 Offset	6 -- Analog I/O	6-28	460	Tr1 Cont Trigger	9 -- Trend Setup	6-38
397	An In 3 Scale	6 -- Analog I/O	6-28	461	Tr1 Select	9 -- Trend Setup	6-38
398	An In 4 Offset	6 -- Analog I/O	6-28	462	Tr1 Status	9 -- Trend I/O	6-38
399	An In 4 Scale	6 -- Analog I/O	6-28	463	Trend Out 1	9 -- Trend I/O	6-38
400	An Out 1 Offset	6 -- Analog I/O	6-29	464	Trend In 2	9 -- Trend I/O	6-39
401	An Out 1 Scale	6 -- Analog I/O	6-29	465	Tr2 Opnd Parm X	9 -- Trend Setup	6-39
402	An Out 2 Offset	6 -- Analog I/O	6-29	466	Tr2 Opnd Parm Y	9 -- Trend Setup	6-39
403	An Out 2 Scale	6 -- Analog I/O	6-29	467	Tr2 Operator	9 -- Trend Setup	6-39
404	An Out 3 Offset	6 -- Analog I/O	6-30	468	Tr2 Sample Rate	9 -- Trend Setup	6-40
405	An Out 3 Scale	6 -- Analog I/O	6-30	469	Tr2 Post Samples	9 -- Trend Setup	6-40
406	An Out 4 Offset	6 -- Analog I/O	6-30	470	Tr2 Cont Trigger	9 -- Trend Setup	6-40
407	An Out 4 Scale	6 -- Analog I/O	6-30	471	Tr2 Select	9 -- Trend Setup	6-40
408	Port Enable	4 -- Masks	6-31	472	Tr2 Status	9 -- Trend I/O	6-40
409	Dir Mask	4 -- Masks	6-31	473	Trend Out 2	9 -- Trend I/O	6-41
410	Start Mask	4 -- Masks	6-31	474	Trend In 3	9 -- Trend I/O	6-41
411	Jog Mask	4 -- Masks	6-31	475	Tr3 Opnd Parm X	9 -- Trend Setup	6-41
412	Ref Mask	4 -- Masks	6-31	476	Tr3 Opnd Parm Y	9 -- Trend Setup	6-41
413	Clr Fault Mask	4 -- Masks	6-32	477	Tr3 Operator	9 -- Trend Setup	6-42
414	Reset Drive Mask	4 -- Masks	6-32	478	Tr3 Sample Rate	9 -- Trend Setup	6-42
415	Local Mask	4 -- Masks	6-32	479	Tr3 Post Samples	9 -- Trend Setup	6-42
416	SP Default Ref	3 -- Velocity Ref	6-32	480	Tr3 Cont Trigger	9 -- Trend Setup	6-42
425	ICN Fault Sel	2 -- Adapter Diagnostics	6-33	481	Tr3 Select	9 -- Trend Setup	6-43
426	ICN Warn Sel	2 -- Adapter Diagnostics	6-34	482	Tr3 Status	9 -- Trend I/O	6-43
427	*			483	Trend Out 3	9 -- Trend I/O	6-43
430	*			484	Trend In 4	9 -- Trend I/O	6-44
431	*			485	Tr4 Opnd Parm X	9 -- Trend Setup	6-44
432	*			486	Tr4 Opnd Parm Y	9 -- Trend Setup	6-44
435	DIP Fault Setup	2 -- Adapter Diagnostics	6-35	487	Tr4 Operator	9 -- Trend Setup	6-44
436	*			488	Tr4 Sample Rate	9 -- Trend Setup	6-44
437	*			489	Tr4 Post Samples	9 -- Trend Setup	6-45
438	*			490	Tr4 Cont Trigger	9 -- Trend Setup	6-45
439	*			491	Tr4 Select	9 -- Trend Setup	6-45
440	SP Fault Sel	2 -- Adapter Diagnostics	6-35	492	Tr4 Status	9 -- Trend I/O	6-45
441	SP Warn Sel	2 -- Adapter Diagnostics	6-35	493	Trend Out 4	9 -- Trend I/O	6-46
442	SP Fault Sts	2 -- Adapter Diagnostics	6-36				

* Not Used in this application

Parameter Files and Groups

Parameters are divided into four files to help ease programming and operator access. The four files are:

- Startup file
- Communications I/O file
- Velocity Torque file
- Diagnostics file

These files are divided into groups, and each parameter is an element in a specific group. Parameters may be used as elements in more than one group.

You can also view the parameters in a linear mode. This allows you to view the entire parameter table in numerical order. For additional information on parameter viewing modes, refer to the 1336 FORCE User Manual.

The following tables list the parameters that are available in each file and group. Descriptions of the shaded parameters are located in the 1336 FORCE User Manual.

File 1 – Startup^①

Drive Data Group		Drive Tune Group		Limits Group	
Language Sel	309	Autotun Diag Sel	256	Accel Time	125
Encoder PPR	235	Vel Feedback	146	Decel Time	126
Base Motor Speed	229	Vel Desired BW	43	Logic Options	59
Base Motor HP	228	Auto Tune Status	44	Fwd Speed Limit	128
Base Motor Curr	230	Motor Inertia	234	Rev Speed Limit	127
Base Motor Volt	231	Total Inertia	46	Pos Mtr Cur Lmt	179
Base Motor Freq	232	Ki Velocity Loop	139	Neg Mtr Cur Lmt	180
Motor Poles	233	Kp Velocity Loop	140	Pos Mtr Tor Lmt	175
Torque Mode Sel	53	Kf Velocity Loop	141	Neg Mtr Tor Lmt	176
		Vel Damp Factor	45	Motor Power Lmt	177
		Auto Tune Speed	41	Regen Power Lmt	178
		Ph Rot Cur Ref	262	Di/Dt Limit	181
		Ph Rot Freq Ref	263	Min Flux Level	174

Fault Setup Group		Monitor Group	
CP Flt/Warn Cfg	86	Filt Vel Fdbk	269
CP Warn/None Cfg	88	Scaled Vel Fdbk	147
VP Flt/Warn Cfg	87	Int Torque Ref	167
VP Warn/None Cfg	89	Internal Iq Ref	168
Absolute Overspd	90	Computed Power	182
Stall Delay	91	DC Bus Voltage	268
Mtr Overload Lim	92	Motor Volt Fdbk	265
Mtr Overload Spd1	95	Motor Curr Fdbk	264
Mtr Overload Spd2	96	Freq Command	266
Min Overload Lmt	97	Inv Temp Fdbk	270
Service Factor	94	Torque Mode Stat	184
		Lim Motor Flux	271
		Enc Pos Fdbk Low	148
		Enc Pos Fdbk Hi	149
		MCB Counter	8

① Descriptions of the shaded parameters are located in the 1336 FORCE user manual.

File 2 – Communications I/O

Channel A Group		Logic Group		Analog Input Group		Analog Output Group	
CntrlNet In 0	322	ChA Logic Cmd In	367	Analog In 1	339	Analog Out 1	387
CntrlNet In 1	323	Logic Command	52	An In 1 Offset	392	An Out 1 Offset	400
CntrlNet In 2	324	Logic Status Low	56	An In 1 Scale	393	An Out 1 Scale	401
CntrlNet In 3	325	Logic Status Hi	57	Analog In 2	340	Analog Out 2	388
CntrlNet In 4	326	Logic Options	59	An In 2 Offset	394	An Out 2 Offset	402
CntrlNet In 5	327			An In 2 Scale	395	An Out 2 Scale	403
CntrlNet In 6	328			Analog In 3	341	Analog Out 3	389
CntrlNet In 7	329			An In 3 Offset	396	An Out 3 Offset	404
CntrlNet Out 0	351			An In 3 Scale	397	An Out 3 Scale	405
CntrlNet Out 1	352			Analog In 4	342	Analog Out 4	390
CntrlNet Out 2	353			An In 4 Offset	398	An Out 4 Offset	406
CntrlNet Out 3	354			An In 4 Scale	399	An Out 4 Scale	407
CntrlNet Out 4	355			SP Analog In	338	SP Analog Out	386
CntrlNet Out 5	356			SP Analog Sel	391		
CntrlNet Out 6	357						
CntrlNet Out 7	358						

Drv – Drv	Fault Sel/Sts	SCANport Owners	SCANport Masks	SCANport I/O					
D2D Tsk Interval	9	SP Fault Sts	442	Stop Owner	369	Port Enable Mask	408	Data In A1	314
D2D Baud Rate	10	SP Warn Sts	443	Start Owner	371	Start Mask	410	Data In A2	315
D2D Xmit Addr	11	SP Fault Sel	440	Jog1 Owner	372	Jog Mask	411	Data In B1	316
D2D Xmit Ind 1	14	SP Warn Sel	441	Jog2 Owner	373	Direction Mask	409	Data In B2	317
D2D Xmit Data 1	20	ICN Fault Sel	425	Direction Owner	370	Reference Mask	412	Data In C1	318
D2D Xmit Ind 2	15	ICN Warn Sel	426	Set Ref Owner	374	Local Mask	415	Data In C2	319
D2D Xmit Data 2	21	CP Flt Status	82	Local Owner	375	Clear Fault Mask	413	Data In D1	320
D2D Rcv 1 Addr	12	VP Flt Status	83	Flux Owner	376	Reset Drive Mask	414	Data In D2	321
D2D Rcv 1 Ind 1	16	CP Warn Status	84	Trim Owner	377			Data Out A1	343
D2D Rcv 1 Data 1	22	VP Warn Status	85	Ramp Owner	378			Data Out A2	344
D2D Rcv 1 Ind 2	17	CP Fault Select	86	Clr Fault Owner	379			Data Out B1	345
D2D Rcv 2 Data 2	23	CP Warn Select	87					Data Out B2	346
D2D Rcv 2 Addr	13	VP Fault Select	88					Data Out C1	347
D2D Rcv 2 Ind 1	18	VP Warn Select	89					Data Out C2	348
D2D Rcv 2 Data 1	24	Ncfg Flt Status	81					Data Out D1	349
D2D Rcv 2 Ind 2	19	PwrUp Flt Status	80					Data Out D2	350
D2D Rcv 2 Data 2	25	Max DB Power	77						
		Max DB Temp	78						
		DB Time Const	79						
		NOT USED	427						
		NOT USED	430						
		NOT USED	431						
		NOT USED	436						
		NOT USED	437						
		NOT USED	438						

① Descriptions of the shaded parameters are located in the 1336 FORCE user manual.

File 3 – Velocity Torque^①

Velocity Ref		Logic		Velocity Fdbk		Velocity Reg		Torque Ref	
Preset Speed 1	119	ChA Logic Cmd In	367	Filt Vel Fdbk	269	Vel Reg Output	134	Torque Mode Sel	53
Preset Speed 2	120	Logic Command	52	Vel Feedback	146	Ki Velocity Loop	139	Torq Mode Stat	184
Preset Speed 3	121	Torq Stop Confg	58	Scaled Vel Fdbk	147	Kp Velocity Loop	140	Pos Mtr Cur Lmt	179
Preset Speed 4	122	Logic Options	59	Enc Pos Fdbk Low	148	Kf Velocity Loop	141	Neg Mtr Cur Lmt	180
Preset Speed 5	123	Logic Status Low	56	Enc Pos Fdbk Hi	149	Velocity Error	138	Int Torque Ref	167
Jog Speed 1	117	Logic Status Hi	57	Fdbk Track Gain	151	Vel Reg TP Sel	137	Internal Iq Ref	168
Jog Speed 2	118	At Setpoint 1	60	Fdbk Filter Gain	153	Vel Reg TP Low	135	Computed Power	182
Vel Ref 1 Low	100	At Setpoint 2	61	Fdbk Filter BW	154	Vel Reg TP Hi	136	Torq Lmt Stat	183
Vel Ref 1 Hi	101	Over Setpoint 1	62	Fdbk Device Type	150			External Iq Ref	161
Vel Ref 2 Low	103	Over Setpoint 2	63	Fdbk Filter Sel	152			Ext Torq Ref 1	162
Vel Ref 2 Hi	104	Over Setpoint 3	64	Tach Velocity	155			Ext Torq Ref 2	164
Vel Scale Fctr 1	102	Over Setpoint 4	65	Error Filter BW	142			Slave Torque % 1	163
Vel Scale Fctr 2	105	Setpoint Select	66	Vel Fdbk TP Sel	145			Slave Torque % 2	165
Vel Trim Low	106	Speed Setpnt Tol	67	Vel Fdbk TP Low	143			Ext Torque Step	166
Vel Trim Hi	107	Cur Setpoint Tol	68	Vel Fdbk TP Hi	144			Notch Filter Freq	156
Vel Ref Out Low	132	Zero Speed Tol	69					Notch Filter Q	157
Vel Ref Out Hi	133	Local In Status	54					Min Flux Level	174
Accel Time	125	Stop Dwell	72					Pos Mtr Tor Lmt	175
Decel Time	126	Local Out Status	55					Neg Mtr Tor Lmt	176
Fwd Speed Limit	128	Logic Tstpt Sel	71					Motor Power Lmt	177
Rev Speed Limit	127							Regen Power Lmt	178
Max Rev Spd Trim	129							Di/Dt Limit	181
Max Fwd Spd Trim	130							Torq Ref TP Sel	173
Droop Percent	131							Torque Ref TP	172
Vel Ref TP Sel	110								
Vel Ref TP Low	108								
Vel Ref TP Hi	109								
SP Default Ref	416								

^① Descriptions of the shaded parameters are located in the 1336 FORCE user manual.

Torque Block ^①		Process Trim		Torque Autotune		Velocity Autotune	
PWM Frequency	222	Proc Trim Ref	27	Autotun Diag Sel	256	Autotun Diag Sel	256
Prech Rdthru Sel	223	Proc Trim Fdbk	28	Ph Rot Cur Ref	262	Auto Tune Torque	40
Under Volt Stpnt	224	Proc Trim Output	26	Auto Tune Torque	40	Auto Tune Speed	41
Prechg Timeout	225	Proc Trim Select	29	Auto Tune Speed	41	Total Inertia	46
Ridethru Timeout	226	Proc Trim Ki	32	Ph Rot Freq Ref	263	Motor Inertia	234
CP Options	227	Proc Trim Kp	33	Phs Test Rot Error	294	Auto Tune Status	44
Ki Freq Reg	287	Proc Trim Lo Lmt	34	Lo Test Error	295	Vel Desired BW	43
Kp Freq Reg	288	Proc Trim Hi Lmt	35	Rs Test Error	296	Vel Damp Factor	45
Kff Freq Reg	289	Proc Trim Fltr W	30	Id Test Error	297	Ki Velocity Loop	139
Ksel Freq Reg	290	Proc Trim Data	31	Torq Calc Error	298	Kp Velocity Loop	140
Freq Track Filt	291	Proc Trim Out K	36	Stator Res	236	Kf Velocity Loop	141
Track Filt Type	292	Proc Trim TP Sel	38	Leakage Ind	237	Auto Tune TP Sel	48
Freq Trim Filter	293	Proc Trim TP	37	Base Flux Cur	238	Auto Tune TP	47
				Base Torque Cur	240		
				Base Torque Volt	241		
				Base Flux Volt	242		
				Vde Max	243		
				Vqe Max	244		
				Vde Min	245		
				Base Slip Freq	246		
				Base Slip Fr Max	247		
				Base Slip Fr Min	248		
				Kp Slip	249		
				Ki Slip	250		
				Kp Flux	251		
				Ki Flux	252		
				Torq TP Sel 1	273		
				Torq TP Data 1	274		

^① Descriptions of the shaded parameters are located in the 1336 FORCE user manual.

File 4 – Diagnostics^①

Monitor		Testpoints		Fault Sel/Sts		Motor Overload	
Filt Vel Fdbk	269	Vel Fdbk TP Sel	145	SP Fault Sts	442	Mtr Overload Lim	92
Scaled Vel Fdbk	147	Vel Fdbk TP Low	143	SP Warn Sts	443	Mtr Overld Spd 1	95
Int Torque Ref	167	Vel Fdbk TP Hi	144	SP Fault Sel	440	Mtr Overld Spd 2	96
Internal Iq Ref	168	Vel Reg TP Sel	137	SP Warn Sel	441	Min Overload Lmt	97
Computed Power	182	Vel Reg TP Low	135	ICN Flt Sel	425	Service Factor	94
DC Bus Voltage	268	Vel Reg TP Hi	136	ICN Warn Sel	426		
Motor Volt Fdbk	265	Vel Ref TP Sel	110	CP Flt Status	82		
Motor Curr Fdbk	264	Vel Ref TP Low	108	VP Flt Status	83		
Freq Command	266	Vel Ref TP Hi	109	CP Warn Status	84		
Inv Temp Fdbk	270	Auto Tune TP Sel	48	VP Warn Status	85		
Torq Mode Stat	184	Auto Tune TP	47	CP Fault Select	86		
Lim Motor Flux	271	Logic Tstpt Sel	71	CP Warn Select	87		
Enc Pos Fdbk Low	148	Logic Tstpt Data	70	VP Fault Select	88		
Enc Pos Fdbk Hi	149	Fault TP Sel	99	VP Warn Select	89		
MCB Counter	8	Fault TP	98	Ncfig Flt Status	81		
		Torq Ref TP Sel	173	PwrUp Flt Status	80		
		Torque Ref TP	172	Max DB Power	77		
		Torq TP Sel 1	273	Max DB Temp	78		
		Torq TP Data 1	274	DB Time Const	79		
				NOT USED	427		
				NOT USED	430		
				NOT USED	431		
				NOT USED	436		
				NOT USED	437		
				NOT USED	439		

^① Descriptions of the shaded parameters are located in the 1336 FORCE user manual.

Transistor Diag ^①		Trend I/O		Trend Setup		Info	
Autotun Diag Sel	256	Tr1 Status	462	Tr1 Opnd Parm X	455	Drive SW Version	1
Logic Options	59	Tr2 Status	472	Tr1 Opnd Parm Y	456	Drive Type	5
Tran Diag Disabl	257	Tr3 Status	482	Tr1 Operator	457	Base Drive Curr	220
Inverter Diag 1	258	Tr4 Status	492	Tr1 Sample Rate	458	Base Line Volt	221
Inverter Diag 2	259	Trend In 1	454	Tr1 Post Samples	459	Adapter Version	301
Iq Offset	260	Trend In 2	464	Tr1 Cont Trigger	460	Adapter ID	300
Id Offset	261	Trend In 3	474	Tr1 Select	461	Language Sel	309
		Trend In 4	484	Tr2 Opnd Parm X	465	SP Comm Retries	302
		Trend Out 1	463	Tr2 Opnd Parm Y	466	ICN Status	307
		Trend Out 2	473	Tr2 Operator	467	ChA LED State	305
		Trend Out 3	483	Tr2 Sample Rate	468	DIP Switch ChA	303
		Trend Out 4	493	Tr2 Post Samples	469		
				Tr2 Cont Trigger	470		
				Tr2 Select	471		
				Tr3 Opnd Parm X	475		
				Tr3 Opnd Parm Y	476		
				Tr3 Operator	477		
				Tr3 Sample Rate	478		
				Tr3 Post Samples	479		
				Tr3 Cont Trigger	480		
				Tr3 Select	481		
				Tr4 Opnd Parm X	485		
				Tr4 Opnd Parm Y	486		
				Tr4 Operator	487		
				Tr4 Sample Rate	488		
				Tr4 Post Samples	489		
				Tr4 Cont Trigger	490		
				Tr4 Select	491		

^① Descriptions of the shaded parameters are located in the 1336 FORCE user manual.

Parameter Conventions

The remainder of this chapter describes the parameters associated with the ControlNet Adapter Board. For parameters not listed in this section, refer to the parameter descriptions in your 1336 FORCE user manual.

Parameter descriptions adhere to the following conventions.

Par #	[Parameter Name]	Parameter Number	①	#
	Parameter description.	Parameter Type	②	Read Only or Read/Write
		Display Units / Drive Units	④, ⑤	User Units / Internal Drive Units
		Factory Default	③	Drive Factory Setting
		Minimum Value	⑥	Minimum Value Acceptable
		Maximum Value	⑦	Maximum Value Acceptable
		File – Group	⑧	File and Group that Parameter Is In
		Enums	⑨	Values

- ① **Parameter Number** Each parameter is assigned a number. The number can be used for process display set up, fault buffer interpretation, or serial communications.
- ② **Parameter Type** Two types of parameters are available:
- Read Only* The value is changed only by the drive and is used to monitor values.
- Read/Write* The value is changed through programming. This type can also be used to monitor a value.
- ③ **Factory Default** This is the value assigned to each parameter at the factory.
- ④ **Display Units** These are the units that appear on the HIM display. Two types exist:
- ENUMS* A language statement pertaining to the selection made or language description of bit function.
- Engineering* Standard units such as: Hz, seconds, volts, etc.
- ⑤ **Drive Units** These are internal units used to communicate through the serial port and to scale values properly when reading or writing to the drive.
- ⑥ **Minimum Value** This is the lowest setting possible for the parameter.
- ⑦ **Maximum Value** This is the highest setting possible for the parameter.
- ⑧ **File – Group** This lists the File and Group where the parameter is located. A parameter may be listed in more than one File and Group.
- ⑨ **Enums** This lists the bit values that you can use and the associated meanings.

300 Adapter ID [Adapter ID] Adapter ID displays the identifier for the ControlNet Adapter Board.	<table border="0"> <tr><td>Parameter Number</td><td>300</td></tr> <tr><td>Parameter Type</td><td>Read Only, Source</td></tr> <tr><td>Display Units / Drive Units</td><td>None</td></tr> <tr><td>Factory Default</td><td>1</td></tr> <tr><td>Minimum Value</td><td>1</td></tr> <tr><td>Maximum Value</td><td>1</td></tr> <tr><td>File – Group</td><td>Diagnostics – Info</td></tr> </table>	Parameter Number	300	Parameter Type	Read Only, Source	Display Units / Drive Units	None	Factory Default	1	Minimum Value	1	Maximum Value	1	File – Group	Diagnostics – Info		
Parameter Number	300																
Parameter Type	Read Only, Source																
Display Units / Drive Units	None																
Factory Default	1																
Minimum Value	1																
Maximum Value	1																
File – Group	Diagnostics – Info																
301 Adapter Version [Adapter Version] Adapter Version displays the current firmware version of the ControlNet Adapter Board.	<table border="0"> <tr><td>Parameter Number</td><td>301</td></tr> <tr><td>Parameter Type</td><td>Read Only, Source</td></tr> <tr><td>Display Units / Drive Units</td><td>None</td></tr> <tr><td>Factory Default</td><td>5.xx</td></tr> <tr><td>Minimum Value</td><td>0.00</td></tr> <tr><td>Maximum Value</td><td>9.99</td></tr> <tr><td>File – Group</td><td>Diagnostics – Info</td></tr> </table>	Parameter Number	301	Parameter Type	Read Only, Source	Display Units / Drive Units	None	Factory Default	5.xx	Minimum Value	0.00	Maximum Value	9.99	File – Group	Diagnostics – Info		
Parameter Number	301																
Parameter Type	Read Only, Source																
Display Units / Drive Units	None																
Factory Default	5.xx																
Minimum Value	0.00																
Maximum Value	9.99																
File – Group	Diagnostics – Info																
302 SCANport Communications Retries [SP Comm Retries] SP Comm Retries counts the number of communication retries for all entries in the SCANport scan list.	<table border="0"> <tr><td>Parameter Number</td><td>302</td></tr> <tr><td>Parameter Type</td><td>Read, Source</td></tr> <tr><td>Display Units / Drive Units</td><td>None</td></tr> <tr><td>Factory Default</td><td>0</td></tr> <tr><td>Minimum Value</td><td>0</td></tr> <tr><td>Maximum Value</td><td>65535</td></tr> <tr><td>File – Group</td><td>Diagnostics – Info</td></tr> </table>	Parameter Number	302	Parameter Type	Read, Source	Display Units / Drive Units	None	Factory Default	0	Minimum Value	0	Maximum Value	65535	File – Group	Diagnostics – Info		
Parameter Number	302																
Parameter Type	Read, Source																
Display Units / Drive Units	None																
Factory Default	0																
Minimum Value	0																
Maximum Value	65535																
File – Group	Diagnostics – Info																
303 Channel A DIP Switch [DIP Switch ChA] ChA DIP Switch displays the current U3 dip switch settings in the lower byte. The upper byte (left) is constant.	<table border="0"> <tr><td>Parameter Number</td><td>303</td></tr> <tr><td>Parameter Type</td><td>Read Only, Source</td></tr> <tr><td>Display Units / Drive Units</td><td>Bits</td></tr> <tr><td>Factory Default</td><td>0100 1100 0000 0000</td></tr> <tr><td>Minimum Value</td><td>0100 1100 0000 0000</td></tr> <tr><td>Maximum Value</td><td>0100 1100 1111 1111</td></tr> <tr><td>File – Group</td><td>Diagnostics – Info</td></tr> </table>	Parameter Number	303	Parameter Type	Read Only, Source	Display Units / Drive Units	Bits	Factory Default	0100 1100 0000 0000	Minimum Value	0100 1100 0000 0000	Maximum Value	0100 1100 1111 1111	File – Group	Diagnostics – Info		
Parameter Number	303																
Parameter Type	Read Only, Source																
Display Units / Drive Units	Bits																
Factory Default	0100 1100 0000 0000																
Minimum Value	0100 1100 0000 0000																
Maximum Value	0100 1100 1111 1111																
File – Group	Diagnostics – Info																
305 Channel A LED State [ChA LED State] ChA LED State displays the current LED state for channel A. The LED states correspond to LEDs D8, D10, and D12 on the ControlNet Adapter Board.	<table border="0"> <tr><td>Parameter Number</td><td>305</td></tr> <tr><td>Parameter Type</td><td>Read Only, Source</td></tr> <tr><td>Display Units / Drive Units</td><td>None</td></tr> <tr><td>Factory Default</td><td>0</td></tr> <tr><td>Minimum Value</td><td>0</td></tr> <tr><td>Maximum Value</td><td>5</td></tr> <tr><td>File – Group</td><td>Diagnostics – Info</td></tr> <tr><td>Enums</td><td>0 = Off 1 = Red 2 = Green 3 = Yellow 4 = Flash Green 5 = Flash Red</td></tr> </table>	Parameter Number	305	Parameter Type	Read Only, Source	Display Units / Drive Units	None	Factory Default	0	Minimum Value	0	Maximum Value	5	File – Group	Diagnostics – Info	Enums	0 = Off 1 = Red 2 = Green 3 = Yellow 4 = Flash Green 5 = Flash Red
Parameter Number	305																
Parameter Type	Read Only, Source																
Display Units / Drive Units	None																
Factory Default	0																
Minimum Value	0																
Maximum Value	5																
File – Group	Diagnostics – Info																
Enums	0 = Off 1 = Red 2 = Green 3 = Yellow 4 = Flash Green 5 = Flash Red																

307 ICN Board Status [ICN Status]	Parameter Number	307
	Parameter Type	Read Only, Source
ICN Status displays the status of the ControlNet Adapter Board. You can use this parameter to determine if no fault occurred, or if a warning, soft fault, or hard fault occurred.	Display Units / Drive Units	None
	Factory Default	0
	Minimum Value	0
	Maximum Value	3
	File – Group	Diagnostics – Info
	Enums	0 = No Faults 1 = Drv Warning 2 = Drv Soft Flt 3 = Drv Hard Flt

309 Language Select [Language Sel]	Parameter Number	309
	Parameter Type	Read Only
You can use Language Sel to choose the language you want the ControlNet Adapter Board to use for parameter and fault display text. Currently, only English is available.	Display Units / Drive Units	None
	Factory Default	0
	Minimum Value	0
	Maximum Value	1
	File – Group	Startup – Drive Data Group Diagnostics – Info
	Enums	0 = English 1 = Alternate Language (not currently available)

314 Data Input A1 [Data In A1]	Parameter Number	314
	Parameter Type	Read Only, Source
Data In A1 contains the first image word from the SCANport output image table.	Display Units / Drive Units	None
	Factory Default	0
	Minimum Value	-32767
	Maximum Value	+32767
	File – Group	Communications I/O – SCANport I/O

315 Data Input A2 [Data In A2]	Parameter Number	315
	Parameter Type	Read Only, Source
Data In A2 contains the second image word from the SCANport output image table.	Display Units / Drive Units	None
	Factory Default	0
	Minimum Value	-32767
	Maximum Value	+32767
	File – Group	Communications I/O – SCANport I/O

316 Data Input B1 [Data In B1]	Parameter Number	316
	Parameter Type	Read Only, Source
Data In B1 contains the third image word from the SCANport output image table.	Display Units / Drive Units	None
	Factory Default	0
	Minimum Value	-32767
	Maximum Value	+32767
	File – Group	Communications I/O – SCANport I/O

317 Data Input B2 [Data In B2]	Parameter Number	317
	Parameter Type	Read Only, Source
Data In B2 contains the fourth image word from the SCANport output image table.	Display Units / Drive Units	None
	Factory Default	0
	Minimum Value	-32767
	Maximum Value	+32767
	File – Group	Communications I/O – SCANport I/O

<p>318 Data Input C1 [Data In C1]</p> <p>Data In C1 contains the fifth image word from the SCANport output image table.</p>	<table> <tr><td>Parameter Number</td><td>318</td></tr> <tr><td>Parameter Type</td><td>Read Only, Source</td></tr> <tr><td>Display Units / Drive Units</td><td>None</td></tr> <tr><td>Factory Default</td><td>0</td></tr> <tr><td>Minimum Value</td><td>-32767</td></tr> <tr><td>Maximum Value</td><td>+32767</td></tr> <tr><td>File - Group</td><td>Communications I/O - SCANport I/O</td></tr> </table>	Parameter Number	318	Parameter Type	Read Only, Source	Display Units / Drive Units	None	Factory Default	0	Minimum Value	-32767	Maximum Value	+32767	File - Group	Communications I/O - SCANport I/O
Parameter Number	318														
Parameter Type	Read Only, Source														
Display Units / Drive Units	None														
Factory Default	0														
Minimum Value	-32767														
Maximum Value	+32767														
File - Group	Communications I/O - SCANport I/O														
<p>319 Data Input C2 [Data In C2]</p> <p>Data In C2 contains the sixth image word from the SCANport output image table.</p>	<table> <tr><td>Parameter Number</td><td>319</td></tr> <tr><td>Parameter Type</td><td>Read Only, Source</td></tr> <tr><td>Display Units / Drive Units</td><td>None</td></tr> <tr><td>Factory Default</td><td>0</td></tr> <tr><td>Minimum Value</td><td>-32767</td></tr> <tr><td>Maximum Value</td><td>+32767</td></tr> <tr><td>File - Group</td><td>Communications I/O - SCANport I/O</td></tr> </table>	Parameter Number	319	Parameter Type	Read Only, Source	Display Units / Drive Units	None	Factory Default	0	Minimum Value	-32767	Maximum Value	+32767	File - Group	Communications I/O - SCANport I/O
Parameter Number	319														
Parameter Type	Read Only, Source														
Display Units / Drive Units	None														
Factory Default	0														
Minimum Value	-32767														
Maximum Value	+32767														
File - Group	Communications I/O - SCANport I/O														
<p>320 Data Input D1 [Data In D1]</p> <p>Data In D1 contains the seventh image word from the SCANport output image table.</p>	<table> <tr><td>Parameter Number</td><td>320</td></tr> <tr><td>Parameter Type</td><td>Read Only, Source</td></tr> <tr><td>Display Units / Drive Units</td><td>None</td></tr> <tr><td>Factory Default</td><td>0</td></tr> <tr><td>Minimum Value</td><td>-32767</td></tr> <tr><td>Maximum Value</td><td>+32767</td></tr> <tr><td>File - Group</td><td>Communications I/O - SCANport I/O</td></tr> </table>	Parameter Number	320	Parameter Type	Read Only, Source	Display Units / Drive Units	None	Factory Default	0	Minimum Value	-32767	Maximum Value	+32767	File - Group	Communications I/O - SCANport I/O
Parameter Number	320														
Parameter Type	Read Only, Source														
Display Units / Drive Units	None														
Factory Default	0														
Minimum Value	-32767														
Maximum Value	+32767														
File - Group	Communications I/O - SCANport I/O														
<p>321 Data Input D2 [Data In D2]</p> <p>Data In D2 contains the eighth image word from the SCANport output image table.</p>	<table> <tr><td>Parameter Number</td><td>321</td></tr> <tr><td>Parameter Type</td><td>Read Only, Source</td></tr> <tr><td>Display Units / Drive Units</td><td>None</td></tr> <tr><td>Factory Default</td><td>0</td></tr> <tr><td>Minimum Value</td><td>-32767</td></tr> <tr><td>Maximum Value</td><td>+32767</td></tr> <tr><td>File - Group</td><td>Communications I/O - SCANport I/O</td></tr> </table>	Parameter Number	321	Parameter Type	Read Only, Source	Display Units / Drive Units	None	Factory Default	0	Minimum Value	-32767	Maximum Value	+32767	File - Group	Communications I/O - SCANport I/O
Parameter Number	321														
Parameter Type	Read Only, Source														
Display Units / Drive Units	None														
Factory Default	0														
Minimum Value	-32767														
Maximum Value	+32767														
File - Group	Communications I/O - SCANport I/O														

322 CntlNet Input 0

[CntlNet In 0]

CntlNet In 0 contains the first word or data group from the PLC controller output image table. The ControlNet scanner transfers the data to the drive every rack scan. The ControlNet Adapter Board can use this value directly. Other drive functions can use this value through a configuration link.

Parameter Number	322
Parameter Type	Read Only, Source
Display Units / Drive Units	None
Factory Default	None
Minimum Value	-32767
Maximum Value	+32767
File – Group	Communications I/O – Channel A

323 CntlNet Input 1

[CntlNet In 1]

CntlNet In 1 contains the second word or data group from the PLC controller output image table. The ControlNet scanner transfers the data to the drive every rack scan. The ControlNet Adapter Board can use this value directly. Other drive functions can use this value through a configuration link.

Parameter Number	323
Parameter Type	Read Only, Source
Display Units / Drive Units	None
Factory Default	None
Minimum Value	-32767
Maximum Value	+32767
File – Group	Communications I/O – Channel A

324 CntlNet Input 2

[CntlNet In 2]

CntlNet In 2 contains the third word or data group from the PLC controller output image table. The ControlNet scanner transfers the data to the drive every rack scan. The ControlNet Adapter Board can use this value directly. Other drive functions can use this value through a configuration link.

Parameter Number	324
Parameter Type	Read Only, Source
Display Units / Drive Units	None
Factory Default	None
Minimum Value	-32767
Maximum Value	+32767
File – Group	Communications I/O – Channel A

325 CntlNet Input 3

[CntlNet In 3]

CntlNet In 3 contains the fourth word or data group from the PLC controller output image table. The ControlNet scanner transfers the data to the drive every rack scan. The ControlNet Adapter Board can use this value directly. Other drive functions can use this value through a configuration link.

Parameter Number	325
Parameter Type	Read Only, Source
Display Units / Drive Units	None
Factory Default	None
Minimum Value	-32767
Maximum Value	+32767
File – Group	Communications I/O – Channel A

326 CntlNet Input 4

[CntlNet In 4]

CntlNet In 4 contains the fifth word or data group from the PLC controller output image table. The ControlNet scanner transfers the data to the drive every rack scan. The ControlNet Adapter Board can use this value directly. Other drive functions can use this value through a configuration link.

Parameter Number	326
Parameter Type	Read Only, Source
Display Units / Drive Units	None
Factory Default	None
Minimum Value	-32767
Maximum Value	+32767
File – Group	Communications I/O – Channel A

327 CntlNet Input 5

[CntlNet In 5]

CntlNet In 5 contains the sixth word or data group from the PLC controller output image table. The ControlNet scanner transfers the data to the drive every rack scan. The ControlNet Adapter Board can use this value directly. Other drive functions can use this value through a configuration link.

Parameter Number	327
Parameter Type	Read Only, Source
Display Units / Drive Units	None
Factory Default	None
Minimum Value	-32767
Maximum Value	+32767
File – Group	Communications I/O – Channel A

328 CntlNet Input 6

[CntlNet In 6]

CntlNet In 6 contains the seventh word or data group from the PLC controller output image table. The ControlNet scanner transfers the data to the drive every rack scan. The ControlNet Adapter Board can use this value directly. Other drive functions can use this value through a configuration link.

Parameter Number	328
Parameter Type	Read Only, Source
Display Units / Drive Units	None
Factory Default	None
Minimum Value	-32767
Maximum Value	+32767
File – Group	Communications I/O – Channel A

329 CntlNet Input 7

[CntlNet In 7]

CntlNet In 7 contains the eighth word or data group from the PLC controller output image table. The ControlNet scanner transfers the data to the drive every rack scan. The ControlNet Adapter Board can use this value directly. Other drive functions can use this value through a configuration link.

Parameter Number	329
Parameter Type	Read Only, Source
Display Units / Drive Units	None
Factory Default	None
Minimum Value	-32767
Maximum Value	+32767
File – Group	Communications I/O – Channel A

338 SCANport Analog Input

[SP Analog In]

SP Analog In converts a +10V analog input value to a +32767 value. You can then link this digital value to one of the 1336 FORCE input parameters.

Parameter Number	338
Parameter Type	Read Only, Sink
Display Units / Drive Units	None
Factory Default	None
Minimum Value	-32767
Maximum Value	+32767
File – Group	Communications I/O – Analog Input

<p>339 Analog Input 1 [Analog In 1]</p> <p>Analog In 1 displays the result of converting a $\pm 10V$ signal to a ± 32767 value using Analog In 1 Scale (parameter 393) and Analog In 1 Offset (parameter 392). You can link this digital value to other 1336 FORCE parameters.</p>	<table> <tr><td>Parameter Number</td><td>339</td></tr> <tr><td>Parameter Type</td><td>Read Only, Source</td></tr> <tr><td>Display Units / Drive Units</td><td>None</td></tr> <tr><td>Factory Default</td><td>0</td></tr> <tr><td>Minimum Value</td><td>-32767</td></tr> <tr><td>Maximum Value</td><td>+32767</td></tr> <tr><td>File – Group</td><td>Communications I/O – Analog Input</td></tr> </table>	Parameter Number	339	Parameter Type	Read Only, Source	Display Units / Drive Units	None	Factory Default	0	Minimum Value	-32767	Maximum Value	+32767	File – Group	Communications I/O – Analog Input
Parameter Number	339														
Parameter Type	Read Only, Source														
Display Units / Drive Units	None														
Factory Default	0														
Minimum Value	-32767														
Maximum Value	+32767														
File – Group	Communications I/O – Analog Input														
<p>340 Analog Input 2 [Analog In 2]</p> <p>Analog In 2 displays the result of converting a $\pm 10V$ signal to a ± 32767 value using Analog In 2 Scale (parameter 395) and Analog In 2 Offset (parameter 394). You can link this digital value to other 1336 FORCE parameters.</p>	<table> <tr><td>Parameter Number</td><td>340</td></tr> <tr><td>Parameter Type</td><td>Read Only, Source</td></tr> <tr><td>Display Units / Drive Units</td><td>None</td></tr> <tr><td>Factory Default</td><td>0</td></tr> <tr><td>Minimum Value</td><td>-32767</td></tr> <tr><td>Maximum Value</td><td>+32767</td></tr> <tr><td>File – Group</td><td>Communications I/O – Analog Input</td></tr> </table>	Parameter Number	340	Parameter Type	Read Only, Source	Display Units / Drive Units	None	Factory Default	0	Minimum Value	-32767	Maximum Value	+32767	File – Group	Communications I/O – Analog Input
Parameter Number	340														
Parameter Type	Read Only, Source														
Display Units / Drive Units	None														
Factory Default	0														
Minimum Value	-32767														
Maximum Value	+32767														
File – Group	Communications I/O – Analog Input														
<p>341 Analog Input 3 [Analog In 3]</p> <p>Analog In 3 displays the result of converting a $\pm 10V$ signal to a ± 32767 value using Analog In 3 Scale (parameter 397) and Analog In 3 Offset (parameter 396). You can link this digital value to other 1336 FORCE parameters.</p>	<table> <tr><td>Parameter Number</td><td>341</td></tr> <tr><td>Parameter Type</td><td>Read Only, Source</td></tr> <tr><td>Display Units / Drive Units</td><td>None</td></tr> <tr><td>Factory Default</td><td>0</td></tr> <tr><td>Minimum Value</td><td>-32767</td></tr> <tr><td>Maximum Value</td><td>+32767</td></tr> <tr><td>File – Group</td><td>Communications I/O – Analog Input</td></tr> </table>	Parameter Number	341	Parameter Type	Read Only, Source	Display Units / Drive Units	None	Factory Default	0	Minimum Value	-32767	Maximum Value	+32767	File – Group	Communications I/O – Analog Input
Parameter Number	341														
Parameter Type	Read Only, Source														
Display Units / Drive Units	None														
Factory Default	0														
Minimum Value	-32767														
Maximum Value	+32767														
File – Group	Communications I/O – Analog Input														
<p>342 Analog Input 4 [Analog In 4]</p> <p>Analog In 4 displays the result of converting a $\pm 10V$ signal to a ± 32767 value using Analog In 4 Scale (parameter 399) and Analog In 4 Offset (parameter 398). You can link this digital value to other 1336 FORCE parameters.</p>	<table> <tr><td>Parameter Number</td><td>342</td></tr> <tr><td>Parameter Type</td><td>Read Only, Source</td></tr> <tr><td>Display Units / Drive Units</td><td>None</td></tr> <tr><td>Factory Default</td><td>0</td></tr> <tr><td>Minimum Value</td><td>-32767</td></tr> <tr><td>Maximum Value</td><td>+32767</td></tr> <tr><td>File – Group</td><td>Communications I/O – Analog Input</td></tr> </table>	Parameter Number	342	Parameter Type	Read Only, Source	Display Units / Drive Units	None	Factory Default	0	Minimum Value	-32767	Maximum Value	+32767	File – Group	Communications I/O – Analog Input
Parameter Number	342														
Parameter Type	Read Only, Source														
Display Units / Drive Units	None														
Factory Default	0														
Minimum Value	-32767														
Maximum Value	+32767														
File – Group	Communications I/O – Analog Input														

<p>343 Data Output A1 [Data Out A1]</p> <p>Data Out A1 contains the first image word from the SCANport input image table.</p>	<table> <tr><td>Parameter Number</td><td>343</td></tr> <tr><td>Parameter Type</td><td>Read/Write, Sink</td></tr> <tr><td>Display Units / Drive Units</td><td>None</td></tr> <tr><td>Factory Default</td><td>0</td></tr> <tr><td>Minimum Value</td><td>0 Hex</td></tr> <tr><td>Maximum Value</td><td>FFFF Hex</td></tr> <tr><td>File – Group</td><td>Communications I/O – SCANport I/O</td></tr> </table>	Parameter Number	343	Parameter Type	Read/Write, Sink	Display Units / Drive Units	None	Factory Default	0	Minimum Value	0 Hex	Maximum Value	FFFF Hex	File – Group	Communications I/O – SCANport I/O
Parameter Number	343														
Parameter Type	Read/Write, Sink														
Display Units / Drive Units	None														
Factory Default	0														
Minimum Value	0 Hex														
Maximum Value	FFFF Hex														
File – Group	Communications I/O – SCANport I/O														
<p>344 Data Output A2 [Data Out A2]</p> <p>Data Out A2 contains the second image word from the SCANport input image table.</p>	<table> <tr><td>Parameter Number</td><td>344</td></tr> <tr><td>Parameter Type</td><td>Read/Write, Sink</td></tr> <tr><td>Display Units / Drive Units</td><td>None</td></tr> <tr><td>Factory Default</td><td>0</td></tr> <tr><td>Minimum Value</td><td>0 Hex</td></tr> <tr><td>Maximum Value</td><td>FFFF Hex</td></tr> <tr><td>File – Group</td><td>Communications I/O – SCANport I/O</td></tr> </table>	Parameter Number	344	Parameter Type	Read/Write, Sink	Display Units / Drive Units	None	Factory Default	0	Minimum Value	0 Hex	Maximum Value	FFFF Hex	File – Group	Communications I/O – SCANport I/O
Parameter Number	344														
Parameter Type	Read/Write, Sink														
Display Units / Drive Units	None														
Factory Default	0														
Minimum Value	0 Hex														
Maximum Value	FFFF Hex														
File – Group	Communications I/O – SCANport I/O														
<p>345 Data Output B1 [Data Out B1]</p> <p>Data Out B1 contains the third image word from the SCANport input image table.</p>	<table> <tr><td>Parameter Number</td><td>345</td></tr> <tr><td>Parameter Type</td><td>Read/Write, Sink</td></tr> <tr><td>Display Units / Drive Units</td><td>None</td></tr> <tr><td>Factory Default</td><td>0</td></tr> <tr><td>Minimum Value</td><td>0 Hex</td></tr> <tr><td>Maximum Value</td><td>FFFF Hex</td></tr> <tr><td>File – Group</td><td>Communications I/O – SCANport I/O</td></tr> </table>	Parameter Number	345	Parameter Type	Read/Write, Sink	Display Units / Drive Units	None	Factory Default	0	Minimum Value	0 Hex	Maximum Value	FFFF Hex	File – Group	Communications I/O – SCANport I/O
Parameter Number	345														
Parameter Type	Read/Write, Sink														
Display Units / Drive Units	None														
Factory Default	0														
Minimum Value	0 Hex														
Maximum Value	FFFF Hex														
File – Group	Communications I/O – SCANport I/O														
<p>346 Data Output B2 [Data Out B2]</p> <p>Data Out B2 contains the fourth image word from the SCANport input image table.</p>	<table> <tr><td>Parameter Number</td><td>346</td></tr> <tr><td>Parameter Type</td><td>Read/Write, Sink</td></tr> <tr><td>Display Units / Drive Units</td><td>None</td></tr> <tr><td>Factory Default</td><td>0</td></tr> <tr><td>Minimum Value</td><td>0 Hex</td></tr> <tr><td>Maximum Value</td><td>FFFF Hex</td></tr> <tr><td>File – Group</td><td>Communications I/O – SCANport I/O</td></tr> </table>	Parameter Number	346	Parameter Type	Read/Write, Sink	Display Units / Drive Units	None	Factory Default	0	Minimum Value	0 Hex	Maximum Value	FFFF Hex	File – Group	Communications I/O – SCANport I/O
Parameter Number	346														
Parameter Type	Read/Write, Sink														
Display Units / Drive Units	None														
Factory Default	0														
Minimum Value	0 Hex														
Maximum Value	FFFF Hex														
File – Group	Communications I/O – SCANport I/O														
<p>347 Data Output C1 [Data Out C1]</p> <p>Data Out C1 contains the fifth image word from the SCANport input image table.</p>	<table> <tr><td>Parameter Number</td><td>347</td></tr> <tr><td>Parameter Type</td><td>Read/Write, Sink</td></tr> <tr><td>Display Units / Drive Units</td><td>None</td></tr> <tr><td>Factory Default</td><td>0</td></tr> <tr><td>Minimum Value</td><td>0 Hex</td></tr> <tr><td>Maximum Value</td><td>FFFF Hex</td></tr> <tr><td>File – Group</td><td>Communications I/O – SCANport I/O</td></tr> </table>	Parameter Number	347	Parameter Type	Read/Write, Sink	Display Units / Drive Units	None	Factory Default	0	Minimum Value	0 Hex	Maximum Value	FFFF Hex	File – Group	Communications I/O – SCANport I/O
Parameter Number	347														
Parameter Type	Read/Write, Sink														
Display Units / Drive Units	None														
Factory Default	0														
Minimum Value	0 Hex														
Maximum Value	FFFF Hex														
File – Group	Communications I/O – SCANport I/O														
<p>348 Data Output C2 [Data Out C2]</p> <p>Data Out C2 contains the sixth image word from the SCANport input image table.</p>	<table> <tr><td>Parameter Number</td><td>348</td></tr> <tr><td>Parameter Type</td><td>Read/Write, Sink</td></tr> <tr><td>Display Units / Drive Units</td><td>None</td></tr> <tr><td>Factory Default</td><td>0</td></tr> <tr><td>Minimum Value</td><td>0 Hex</td></tr> <tr><td>Maximum Value</td><td>FFFF Hex</td></tr> <tr><td>File – Group</td><td>Communications I/O – SCANport I/O</td></tr> </table>	Parameter Number	348	Parameter Type	Read/Write, Sink	Display Units / Drive Units	None	Factory Default	0	Minimum Value	0 Hex	Maximum Value	FFFF Hex	File – Group	Communications I/O – SCANport I/O
Parameter Number	348														
Parameter Type	Read/Write, Sink														
Display Units / Drive Units	None														
Factory Default	0														
Minimum Value	0 Hex														
Maximum Value	FFFF Hex														
File – Group	Communications I/O – SCANport I/O														

<p>349 Data Output D1 [Data Out D1]</p> <p>Data Out D1 contains the seventh image word from the SCANport input image table.</p>	<p>Parameter Number 349 Parameter Type Read/Write, Sink Display Units / Drive Units None Factory Default 0 Minimum Value 0 Hex Maximum Value FFFF Hex File – Group Communications I/O – SCANport I/O</p>
<p>350 Data Output D2 [Data Out D2]</p> <p>Data Out D2 contains the eighth image word from the SCANport input image table.</p>	<p>Parameter Number 350 Parameter Type Read/Write, Sink Display Units / Drive Units None Factory Default 0 Minimum Value 0 Hex Maximum Value FFFF Hex File – Group Communications I/O – SCANport I/O</p>
<p>351 CntlNet Out 0 [CntlNet Out 0]</p> <p>CntlNet Out 0 contains the first word or data group to the PLC controller input image table. The data is transferred to the PLC controller every rack scan. The ControlNet Adapter Board can provide this value directly. Other drive functions can provide this value through a configuration link.</p>	<p>Parameter Number 351 Parameter Type Read/Write, Sink Display Units / Drive Units None Factory Default None Minimum Value -32767 Maximum Value +32767 File – Group Communications I/O – Channel A</p>
<p>352 CntlNet Out 1 [CntlNet Out 1]</p> <p>CntlNet Out 1 contains the second word or data group to the PLC controller input image table. The data is transferred to the PLC controller every rack scan. The ControlNet Adapter Board can provide this value directly. Other drive functions can provide this value through a configuration link.</p>	<p>Parameter Number 352 Parameter Type Read/Write, Sink Display Units / Drive Units None Factory Default None Minimum Value -32767 Maximum Value +32767 File – Group Communications I/O – Channel A</p>

353 CntlNet Output 2

[CntlNet Out 2]

CntlNet Out 2 contains the third word or data group to the PLC controller input image table. The data is transferred to the PLC controller every rack scan. The ControlNet Adapter Board can provide this value directly. Other drive functions can provide this value through a configuration link.

Parameter Number	353
Parameter Type	Read/Write, Sink
Display Units / Drive Units	None
Factory Default	None
Minimum Value	-32767
Maximum Value	+32767
File – Group	Communications I/O – Channel A

354 CntlNet Output 3

[CntlNet Out 3]

CntlNet Out 3 contains the fourth word or data group to the PLC controller input image table. The data is transferred to the PLC controller every rack scan. The ControlNet Adapter Board can provide this value directly. Other drive functions can provide this value through a configuration link.

Parameter Number	354
Parameter Type	Read/Write, Sink
Display Units / Drive Units	None
Factory Default	None
Minimum Value	-32767
Maximum Value	+32767
File – Group	Communications I/O – Channel A

355 CntlNet Output 4

[CntlNet Out 4]

CntlNet Out 4 contains the fifth word or data group to the PLC controller input image table. The data is transferred to the PLC controller every rack scan. The ControlNet Adapter Board can provide this value directly. Other drive functions can provide this value through a configuration link.

Parameter Number	355
Parameter Type	Read/Write, Sink
Display Units / Drive Units	None
Factory Default	None
Minimum Value	-32767
Maximum Value	+32767
File – Group	Communications I/O – Channel A

356 CntlNet Output 5

[CntlNet Out 5]

CntlNet Out 5 contains the sixth word or data group to the PLC controller input image table. The data is transferred to the PLC controller every rack scan. The ControlNet Adapter Board can provide this value directly. Other drive functions can provide this value through a configuration link.

Parameter Number	356
Parameter Type	Read/Write, Sink
Display Units / Drive Units	None
Factory Default	None
Minimum Value	-32767
Maximum Value	+32767
File – Group	Communications I/O – Channel A

357 CntlNet Output 6

[CntlNet Out 6]

CntlNet Out 6 contains the seventh word or data group to the PLC controller input image table. The data is transferred to the PLC controller every rack scan. The ControlNet Adapter Board can provide this value directly. Other drive functions can provide this value through a configuration link.

Parameter Number	357
Parameter Type	Read/Write, Sink
Display Units / Drive Units	None
Factory Default	None
Minimum Value	-32767
Maximum Value	+32767
File – Group	Communications I/O – Channel A

358 CntlNet Output 7

[CntlNet Out 7]

CntlNet Out 7 contains the eighth word or data group to the PLC controller input image table. The data is transferred to the PLC controller every rack scan. The ControlNet Adapter Board can provide this value directly. Other drive functions can provide this value through a configuration link.

Parameter Number	358
Parameter Type	Read/Write, Sink
Display Units / Drive Units	None
Factory Default	None
Minimum Value	-32767
Maximum Value	+32767
File – Group	Communications I/O – Channel A

367 ChA Logic Command Input

[ChA Logic Cmd In]

This logic command parameter is for Channel A. ChA Logic Cmd In is permanently linked to parameter 52, logic command word.

Parameter Number	367
Parameter Type	Read/Write, Sink
Display Units / Drive Units	Bits
Factory Default	0 Hex
Minimum Value	0 Hex
Maximum Value	FFFF Hex
File – Group	Communications I/O – Logic Velocity Torque – Logic

Enums

Bit 0 = Normal Stop
 Bit 1 = Start
 Bit 2 = Jog 1
 Bit 3 = Clear Fault
 Bit 4 = Forward
 Bit 5 = Reverse
 Bit 6 = Jog 2
 Bit 7 = I Limit Stop

Bit 8 = Coast Stop
 Bit 9 = Vel Ramp Disable
 Bit 10 = Flux Enable
 Bit 11 = Process Trim
 Bit 12 = Vel Ref A
 Bit 13 = Vel Ref B
 Bit 14 = Vel Ref C
 Bit 15 = Reset Drive

C	B	A	
0	0	0	Zero
0	0	1	External Ref 1 (par 101, 100)
0	1	0	Preset Speed 1 (par 119)
0	1	1	Preset Speed 2 (par 120)
1	0	0	Preset Speed 3 (par 121)
1	0	1	Preset Speed 4 (par 122)
1	1	0	Preset Speed 5 (par 123)
1	1	1	External Ref 2 (par 104, 103)

369 Stop Owner

[Stop Owner]

Stop Owner displays which ports are presently issuing a valid Stop command.

Parameter Number	369
Parameter Type	Read Only, Source
Display Units / Drive Units	Bits
Factory Default	0
Minimum Value	0
Maximum Value	0FE Hex
File – Group	Communications I/O – SCANport Owners

Enums Bit 1 = Port 1 Bit 2 = Port 2 Bit 3 = Port 3 Bit 4 = Port 4
 Bit 5 = Port 5 Bit 6 = Channel A Bit 7 = Channel B

370 Direction Owner

[Dir Owner]

Dir Owner displays which port currently has exclusive control of direction changes.

Parameter Number	370
Parameter Type	Read Only, Source
Display Units / Drive Units	Bits
Factory Default	0
Minimum Value	0
Maximum Value	0FE Hex
File – Group	Communications I/O – SCANport Owners

Enums Bit 1 = Port 1 Bit 2 = Port 2 Bit 3 = Port 3 Bit 4 = Port 4
 Bit 5 = Port 5 Bit 6 = Channel A Bit 7 = Channel B

<p>371 Start Owner [Start Owner]</p> <p>Start Owner displays which ports are presently issuing a valid Start command.</p>	<p>Parameter Number 371 Parameter Type Read Only, Source Display Units / Drive Units Bits Factory Default 0 Minimum Value 0 Maximum Value 0FE Hex File – Group Communications I/O – SCANport Owners Enums Bit 1 = Port 1 Bit 2 = Port 2 Bit 3 = Port 3 Bit 4 = Port 4 Bit 5 = Port 5 Bit 6 = Channel A Bit 7 = Channel B</p>
<p>372 Jog1 Owner [Jog1 Owner]</p> <p>Jog1 Owner displays which ports are presently issuing a valid Jog1 command.</p>	<p>Parameter Number 372 Parameter Type Read Only, Source Display Units / Drive Units Bits Factory Default 0 Minimum Value 0 Maximum Value 0FE Hex File – Group Communications I/O – SCANport Owners Enums Bit 1 = Port 1 Bit 2 = Port 2 Bit 3 = Port 3 Bit 4 = Port 4 Bit 5 = Port 5 Bit 6 = Channel A Bit 7 = Channel B</p>
<p>373 Jog2 Owner [Jog2 Owner]</p> <p>Jog2 Owner displays which ports are presently issuing a valid Jog2 command.</p>	<p>Parameter Number 373 Parameter Type Read Only, Source Display Units / Drive Units Bits Factory Default 0 Minimum Value 0 Maximum Value 0FE Hex File – Group Communications I/O – SCANport Owners Enums Bit 1 = Port 1 Bit 2 = Port 2 Bit 3 = Port 3 Bit 4 = Port 4 Bit 5 = Port 5 Bit 6 = Channel A Bit 7 = Channel B</p>
<p>374 Set Reference Owner [Set Ref Owner]</p> <p>Set Ref Owner displays which port currently has exclusive control in selecting the command frequency source.</p>	<p>Parameter Number 374 Parameter Type Read Only, Source Display Units / Drive Units Bits Factory Default 0 Minimum Value 0 Maximum Value 0FE Hex File – Group Communications I/O – SCANport Owners Enums Bit 1 = Port 1 Bit 2 = Port 2 Bit 3 = Port 3 Bit 4 = Port 4 Bit 5 = Port 5 Bit 6 = Channel A Bit 7 = Channel B</p>
<p>375 Local Owner [Local Owner]</p> <p>Local Owner displays which port has requested exclusive control of all drive logic functions. If a port is in local lockout, all other functions (except stop) on all other ports are locked out and are non-functional.</p>	<p>Parameter Number 375 Parameter Type Read Only, Source Display Units / Drive Units Bits Factory Default 0 Minimum Value 0 Maximum Value 0FE Hex File – Group Communications I/O – SCANport Owners Enums Bit 1 = Port 1 Bit 2 = Port 2 Bit 3 = Port 3 Bit 4 = Port 4 Bit 5 = Port 5 Bit 6 = Channel A Bit 7 = Channel B</p>

<p>376 Flux Owner [Flux Owner]</p> <p>Flux Owner displays which ports are presently issuing a valid Flux Enable command.</p>	<p>Parameter Number 376</p> <p>Parameter Type Read Only, Source</p> <p>Display Units / Drive Units Bits</p> <p>Factory Default 0</p> <p>Minimum Value 0</p> <p>Maximum Value 0FE Hex</p> <p>File – Group Communications I/O – SCANport Owners</p> <p>Enums Bit 1 = Port 1 Bit 2 = Port 2 Bit 3 = Port 3 Bit 4 = Port 4 Bit 5 = Port 5 Bit 6 = Channel A Bit 7 = Channel B</p>
<p>377 Trim Owner [Trim Owner]</p> <p>Trim Owner displays which port is presently issuing a Trim Enable command.</p>	<p>Parameter Number 377</p> <p>Parameter Type Read Only, Source</p> <p>Display Units / Drive Units Bits</p> <p>Factory Default 0</p> <p>Minimum Value 0</p> <p>Maximum Value 0FE Hex</p> <p>File – Group Communications I/O – SCANport Owners</p> <p>Enums Bit 1 = Port 1 Bit 2 = Port 2 Bit 3 = Port 3 Bit 4 = Port 4 Bit 5 = Port 5 Bit 6 = Channel A Bit 7 = Channel B</p>
<p>378 Ramp Owner [Ramp Owner]</p> <p>Ramp Owner displays which port is presently issuing a Ramp command.</p>	<p>Parameter Number 378</p> <p>Parameter Type Read Only, Source</p> <p>Display Units / Drive Units Bits</p> <p>Factory Default 0</p> <p>Minimum Value 0</p> <p>Maximum Value 0FE Hex</p> <p>File – Group Communications I/O – SCANport Owners</p> <p>Enums Bit 1 = Port 1 Bit 2 = Port 2 Bit 3 = Port 3 Bit 4 = Port 4 Bit 5 = Port 5 Bit 6 = Channel A Bit 7 = Channel B</p>
<p>379 Clear Fault Owner [Clr Fault Owner]</p> <p>Clr Fault Owner displays which port is presently issuing a Clear Fault command.</p>	<p>Parameter Number 379</p> <p>Parameter Type Read Only, Source</p> <p>Display Units / Drive Units Bits</p> <p>Factory Default 0</p> <p>Minimum Value 0</p> <p>Maximum Value 0FE Hex</p> <p>File – Group Communications I/O – SCANport Owners</p> <p>Enums Bit 1 = Port 1 Bit 2 = Port 2 Bit 3 = Port 3 Bit 4 = Port 4 Bit 5 = Port 5 Bit 6 = Channel A Bit 7 = Channel B</p>
<p>386 SCANport Analog Output [SP Analog Out]</p> <p>SP Analog Out passes the value it contains to the attached SCANport devices. For example, you can link one of the output parameters to SP Analog Out and each of the five SCANport devices could read the value of the output parameter.</p>	<p>Parameter Number 386</p> <p>Parameter Type Read/Write, Sink</p> <p>Display Units / Drive Units ±32767</p> <p>Factory Default 0</p> <p>Minimum Value -32767</p> <p>Maximum Value +32767</p> <p>File – Group Communications I/O – Analog Output</p>

<p>387 Analog Output 1 [Analog Out 1]</p> <p>Analog Out 1 converts a ± 32767 value to a $\pm 10V$ signal. The digital value is linked to a 1336 FORCE source parameter which provides a value that is scaled and offset. The results are converted to a voltage signal, where ± 2048 results in a $\pm 10V$ output.</p>	<table border="0"> <tr><td>Parameter Number</td><td>387</td></tr> <tr><td>Parameter Type</td><td>Read/Write, Sink</td></tr> <tr><td>Display Units / Drive Units</td><td>± 32767</td></tr> <tr><td>Factory Default</td><td>0</td></tr> <tr><td>Minimum Value</td><td>-32767</td></tr> <tr><td>Maximum Value</td><td>+32767</td></tr> <tr><td>File – Group</td><td>Communication I/O – Analog Output</td></tr> </table>	Parameter Number	387	Parameter Type	Read/Write, Sink	Display Units / Drive Units	± 32767	Factory Default	0	Minimum Value	-32767	Maximum Value	+32767	File – Group	Communication I/O – Analog Output		
Parameter Number	387																
Parameter Type	Read/Write, Sink																
Display Units / Drive Units	± 32767																
Factory Default	0																
Minimum Value	-32767																
Maximum Value	+32767																
File – Group	Communication I/O – Analog Output																
<p>388 Analog Output 2 [Analog Out 2]</p> <p>Analog Out 2 converts a ± 32767 value to a $\pm 10V$ signal. The digital value is linked to a 1336 FORCE source parameter which provides a value that is scaled and offset. The results are converted to a voltage signal, where ± 2048 results in a $\pm 10V$ output.</p>	<table border="0"> <tr><td>Parameter Number</td><td>388</td></tr> <tr><td>Parameter Type</td><td>Read/Write, Sink</td></tr> <tr><td>Display Units / Drive Units</td><td>± 32767</td></tr> <tr><td>Factory Default</td><td>0</td></tr> <tr><td>Minimum Value</td><td>-32767</td></tr> <tr><td>Maximum Value</td><td>+32767</td></tr> <tr><td>File – Group</td><td>Communication I/O – Analog Output</td></tr> </table>	Parameter Number	388	Parameter Type	Read/Write, Sink	Display Units / Drive Units	± 32767	Factory Default	0	Minimum Value	-32767	Maximum Value	+32767	File – Group	Communication I/O – Analog Output		
Parameter Number	388																
Parameter Type	Read/Write, Sink																
Display Units / Drive Units	± 32767																
Factory Default	0																
Minimum Value	-32767																
Maximum Value	+32767																
File – Group	Communication I/O – Analog Output																
<p>389 Analog Output 3 [Analog Out 3]</p> <p>Analog Out 3 converts a ± 32767 value to a $\pm 10V$ signal. The digital value is linked to a 1336 FORCE source parameter which provides a value that is scaled and offset. The results are converted to a voltage signal, where ± 2048 results in a $\pm 10V$ output.</p>	<table border="0"> <tr><td>Parameter Number</td><td>389</td></tr> <tr><td>Parameter Type</td><td>Read/Write, Sink</td></tr> <tr><td>Display Units / Drive Units</td><td>± 32767</td></tr> <tr><td>Factory Default</td><td>0</td></tr> <tr><td>Minimum Value</td><td>-32767</td></tr> <tr><td>Maximum Value</td><td>+32767</td></tr> <tr><td>File – Group</td><td>Communication I/O – Analog Output</td></tr> </table>	Parameter Number	389	Parameter Type	Read/Write, Sink	Display Units / Drive Units	± 32767	Factory Default	0	Minimum Value	-32767	Maximum Value	+32767	File – Group	Communication I/O – Analog Output		
Parameter Number	389																
Parameter Type	Read/Write, Sink																
Display Units / Drive Units	± 32767																
Factory Default	0																
Minimum Value	-32767																
Maximum Value	+32767																
File – Group	Communication I/O – Analog Output																
<p>390 Analog Output 4 [Analog Out 4]</p> <p>Analog Out 4 converts a ± 32767 value to a $\pm 10V$ signal. The digital value is linked to a 1336 FORCE source parameter which provides a value that is scaled and offset. The results are converted to a voltage signal, where ± 2048 results in a $\pm 10V$ output.</p>	<table border="0"> <tr><td>Parameter Number</td><td>390</td></tr> <tr><td>Parameter Type</td><td>Read/Write, Sink</td></tr> <tr><td>Display Units / Drive Units</td><td>± 32767</td></tr> <tr><td>Factory Default</td><td>0</td></tr> <tr><td>Minimum Value</td><td>-32767</td></tr> <tr><td>Maximum Value</td><td>+32767</td></tr> <tr><td>File – Group</td><td>Communication I/O – Analog Output</td></tr> </table>	Parameter Number	390	Parameter Type	Read/Write, Sink	Display Units / Drive Units	± 32767	Factory Default	0	Minimum Value	-32767	Maximum Value	+32767	File – Group	Communication I/O – Analog Output		
Parameter Number	390																
Parameter Type	Read/Write, Sink																
Display Units / Drive Units	± 32767																
Factory Default	0																
Minimum Value	-32767																
Maximum Value	+32767																
File – Group	Communication I/O – Analog Output																
<p>391 SCANport Analog Select [SP Analog Sel]</p> <p>SP Analog Sel indicates which port (1 through 5) is to receive the SCANport analog input value that appears in parameter 338, SP Analog In.</p>	<table border="0"> <tr><td>Parameter Number</td><td>391</td></tr> <tr><td>Parameter Type</td><td>Read/Write, Sink</td></tr> <tr><td>Display Units / Drive Units</td><td>None</td></tr> <tr><td>Factory Default</td><td>1</td></tr> <tr><td>Minimum Value</td><td>1</td></tr> <tr><td>Maximum Value</td><td>5</td></tr> <tr><td>File – Group</td><td>Communications I/O – Analog Output</td></tr> <tr><td>Enums</td><td>1 = Port 1 2 = Port 2 3 = Port 3 4 = Port 4 5 = Port 5</td></tr> </table>	Parameter Number	391	Parameter Type	Read/Write, Sink	Display Units / Drive Units	None	Factory Default	1	Minimum Value	1	Maximum Value	5	File – Group	Communications I/O – Analog Output	Enums	1 = Port 1 2 = Port 2 3 = Port 3 4 = Port 4 5 = Port 5
Parameter Number	391																
Parameter Type	Read/Write, Sink																
Display Units / Drive Units	None																
Factory Default	1																
Minimum Value	1																
Maximum Value	5																
File – Group	Communications I/O – Analog Output																
Enums	1 = Port 1 2 = Port 2 3 = Port 3 4 = Port 4 5 = Port 5																

392 Analog Input 1 Offset

[Analog In 1 Offset]

Analog In 1 Offset determines the offset applied to the raw Analog In 1 values before the scale factor is applied. This allows you to shift the range of the analog input.

Parameter Number	392
Parameter Type	Read/Write, Non-Linkable Sink
Display Units / Drive Units	±4096
Factory Default	0
Minimum Value	-20 Volts
Maximum Value	+20 Volts
File - Group	Communications I/O - Analog Input

393 Analog Input 1 Scale

[Analog In 1 Scale]

Analog In 1 Scale determines the scale factor or gain for the Analog In 1 value. A +10V dc signal applied to Analog In 1 at TB21 is converted to a +2048 digital value used by the 1336 FORCE. Before the digital value is displayed or transferred to the drive, the scale factor is applied allowing an effective digital range of ±32767 (16 x 2048). The absolute digital value is clamped at 32767.

Scale Factor	Drive Units
1	2048
2	4096
4	8192
16	32767

Parameter Number	393
Parameter Type	Read/Write, Non-Linkable Sink
Display Units / Drive Units	±32767
Factory Default	+1
Minimum Value	-16
Maximum Value	+16
File - Group	Communications I/O - Analog Input

394 Analog Input 2 Offset

[Analog In 2 Offset]

Analog In 2 Offset determines the offset applied to the raw Analog In 2 values before the scale factor is applied. This allows you to shift the range of the analog input.

Parameter Number	394
Parameter Type	Read/Write, Non-Linkable Sink
Display Units / Drive Units	±4096
Factory Default	0
Minimum Value	-20 Volts
Maximum Value	+20 Volts
File - Group	Communications I/O - Analog Input

395 Analog Input 2 Scale

[Analog In 2 Scale]

Analog In 2 Scale determines the scale factor or gain for the Analog In 2 value. A +10V dc signal applied to Analog In 2 at TB21 is converted to a +2048 digital value used by the 1336 FORCE. Before the digital value is displayed or transferred to the drive, the scale factor is applied allowing an effective digital range of ±32767 (16 x 2048). The absolute digital value is clamped at 32767.

Scale Factor	Drive Units
1	2048
2	4096
4	8192
16	32767

Parameter Number	395
Parameter Type	Read/Write, Non-Linkable Sink
Display Units / Drive Units	±32767
Factory Default	+1
Minimum Value	-16
Maximum Value	+16
File - Group	Communications I/O - Analog Input

396 Analog Input 3 Offset

[Analog In 3 Offset]

Analog In 3 Offset determines the offset applied to the raw Analog In 3 values before the scale factor is applied. This allows you to shift the range of the analog input.

Parameter Number	396
Parameter Type	Read/Write, Non-Linkable Sink
Display Units / Drive Units	±4096
Factory Default	0
Minimum Value	-20 Volts
Maximum Value	+20 Volts
File - Group	Communications I/O - Analog Input

397 Analog Input 3 Scale

[Analog In 3 Scale]

Analog In 3 Scale determines the scale factor or gain for the Analog In 3 value. A +10V dc signal applied to Analog In 3 at TB21 is converted to a +2048 digital value used by the 1336 FORCE. Before the digital value is displayed or transferred to the drive, the scale factor is applied allowing an effective digital range of ±32767 (16 x 2048). The absolute digital value is clamped at 32767.

Scale Factor	Drive Units
1	2048
2	4096
4	8192
16	32767

Parameter Number	397
Parameter Type	Read/Write, Non-Linkable Sink
Display Units / Drive Units	±32767
Factory Default	+1
Minimum Value	-16
Maximum Value	+16
File - Group	Communications I/O - Analog Input

398 Analog Input 4 Offset

[Analog In 4 Offset]

Analog In 4 Offset determines the offset applied to the raw Analog In 4 values before the scale factor is applied. This allows you to shift the range of the analog input.

Parameter Number	398
Parameter Type	Read/Write, Non-Linkable Sink
Display Units / Drive Units	±4096
Factory Default	0
Minimum Value	-20 Volts
Maximum Value	+20 Volts
File - Group	Communications I/O - Analog Input

399 Analog Input 4 Scale

[Analog In 4 Scale]

Analog In 4 Scale determines the scale factor or gain for the Analog In 4 value. A +10V dc signal applied to Analog In 4 at TB21 is converted to a +2048 digital value used by the 1336 FORCE. Before the digital value is displayed or transferred to the drive, the scale factor is applied allowing an effective digital range of ±32767 (16 x 2048). The absolute digital value is clamped at 32767.

Scale Factor	Drive Units
1	2048
2	4096
4	8192
16	32767

Parameter Number	399
Parameter Type	Read/Write, Non-Linkable Sink
Display Units / Drive Units	±32767
Factory Default	+1
Minimum Value	-16
Maximum Value	+16
File - Group	Communications I/O - Analog Input

400 Analog Output 1 Offset

[Analog Out 1 Offset]

Analog Out 1 Offset determines the offset applied to the Analog Out 1 value after the scale factor is applied. This allows you to shift the range of the analog output.

Parameter Number	400
Parameter Type	Read/Write, Non-Linkable Sink
Display Units / Drive Units	±4096
Factory Default	0
Minimum Value	-20 Volts
Maximum Value	+20 Volts
File – Group	Communications I/O – Analog Output

401 Analog Output 1 Scale

[Analog Out 1 Scale]

Analog Out 1 Scale determines the scale factor or gain for the Analog In 1 value. A +2048 value corresponds to a +10V output signal at TB21. The value sent (linked) to Analog Out 1 is scaled by the corresponding scale parameter before it is offset and converted to an analog signal.

Scale Factor	Drive Units
1	32767
1/2	16383
1/4	8192
1/16	2048

Parameter Number	401
Parameter Type	Read/Write, Non-Linkable Sink
Display Units / Drive Units	±32767
Factory Default	+1
Minimum Value	-1
Maximum Value	+1
File – Group	Communication I/O – Analog Output

402 Analog Output 2 Offset

[Analog Out 2 Offset]

Analog Out 2 Offset determines the offset applied to the Analog Out 2 value after the scale factor is applied. This allows you to shift the range of the analog output.

Parameter Number	402
Parameter Type	Read/Write, Non-Linkable Sink
Display Units / Drive Units	±4096
Factory Default	0
Minimum Value	-20 Volts
Maximum Value	+20 Volts
File – Group	Communications I/O – Analog Output

403 Analog Output 2 Scale

[Analog Out 2 Scale]

Analog Out 2 Scale determines the scale factor or gain for the Analog In 2 value. A +2048 value corresponds to a +10V output signal at TB21. The value sent (linked) to Analog Out 2 is scaled by the corresponding scale parameter before it is offset and converted to an analog signal.

Scale Factor	Drive Units
1	32767
1/2	16383
1/4	8192
1/16	2048

Parameter Number	403
Parameter Type	Read/Write, Non-Linkable Sink
Display Units / Drive Units	±32767
Factory Default	+1
Minimum Value	-1
Maximum Value	+1
File – Group	Communication I/O – Analog Output

404 Analog Output 3 Offset

[Analog Out 3 Offset]

Analog Out 3 Offset determines the offset applied to the Analog Out 3 value after the scale factor is applied. This allows you to shift the range of the analog output.

Parameter Number	404
Parameter Type	Read/Write, Non-Linkable Sink
Display Units / Drive Units	±4096
Factory Default	0
Minimum Value	-20 Volts
Maximum Value	+20 Volts
File – Group	Communications I/O – Analog Output

405 Analog Output 3 Scale

[Analog Out 3 Scale]

Analog Out 3 Scale determines the scale factor or gain for the Analog In 3 value. A +2048 value corresponds to a +10V output signal at TB21. The value sent (linked) to Analog Out 3 is scaled by the corresponding scale parameter before it is offset and converted to an analog signal.

Scale Factor	Drive Units
1	32767
1/2	16383
1/4	8192
1/16	2048

Parameter Number	405
Parameter Type	Read/Write, Non-Linkable Sink
Display Units / Drive Units	±32767
Factory Default	+1
Minimum Value	-1
Maximum Value	+1
File – Group	Communication I/O – Analog Output

406 Analog Output 4 Offset

[Analog Out 4 Offset]

Analog Out 4 Offset determines the offset applied to the Analog Out 4 value after the scale factor is applied. This allows you to shift the range of the analog output.

Parameter Number	406
Parameter Type	Read/Write, Non-Linkable Sink
Display Units / Drive Units	±4096
Factory Default	0
Minimum Value	-20 Volts
Maximum Value	+20 Volts
File – Group	Communications I/O – Analog Output

407 Analog Output 4 Scale

[Analog Out 4 Scale]

Analog Out 4 Scale determines the scale factor or gain for the Analog In 4 value. A +2048 value corresponds to a +10V output signal at TB21. The value sent (linked) to Analog Out 4 is scaled by the corresponding scale parameter before it is offset and converted to an analog signal.

Scale Factor	Drive Units
1	32767
1/2	16383
1/4	8192
1/16	2048

Parameter Number	407
Parameter Type	Read/Write, Non-Linkable Sink
Display Units / Drive Units	±32767
Factory Default	+1
Minimum Value	-1
Maximum Value	+1
File – Group	Communication I/O – Analog Output

<p>408 Port Enable [Port Enable]</p> <p>Port Enable indicates which ports can accept commands listed in parameters 409 through 415.</p>	<p>Parameter Number 408 Parameter Type Read/Write, Non-Linkable Sink Display Units / Drive Units Bits Factory Default 0 Minimum Value 0 Maximum Value 0FE Hex File – Group Communications I/O – SCANport Masks Enums Bit 1 = Port 1 Bit 2 = Port 2 Bit 3 = Port 3 Bit 4 = Port 4 Bit 5 = Port 5 Bit 6 = Channel A Bit 7 = Channel B</p>
<p>409 Direction Mask [Dir Mask]</p> <p>Dir Mask controls which ports can issue forward/reverse commands.</p>	<p>Parameter Number 409 Parameter Type Read/Write, Non-Linkable Sink Display Units / Drive Units Bits Factory Default 0 Minimum Value 0 Maximum Value 0FE Hex File – Group Communications I/O – SCANport Masks Enums Bit 1 = Port 1 Bit 2 = Port 2 Bit 3 = Port 3 Bit 4 = Port 4 Bit 5 = Port 5 Bit 6 = Channel A Bit 7 = Channel B</p>
<p>410 Start Mask [Start Mask]</p> <p>Start Mask controls which ports can issue a start command.</p>	<p>Parameter Number 410 Parameter Type Read/Write, Non-Linkable Sink Display Units / Drive Units Bits Factory Default 0 Minimum Value 0 Maximum Value 0FE Hex File – Group Communications I/O – SCANport Masks Enums Bit 1 = Port 1 Bit 2 = Port 2 Bit 3 = Port 3 Bit 4 = Port 4 Bit 5 = Port 5 Bit 6 = Channel A Bit 7 = Channel B</p>
<p>411 Jog Mask [Jog Mask]</p> <p>Jog Mask controls which ports can issue a jog command.</p>	<p>Parameter Number 411 Parameter Type Read/Write, Non-Linkable Sink Display Units / Drive Units Bits Factory Default 0 Minimum Value 0 Maximum Value 0FE Hex File – Group Communications I/O – SCANport Masks Enums Bit 1 = Port 1 Bit 2 = Port 2 Bit 3 = Port 3 Bit 4 = Port 4 Bit 5 = Port 5 Bit 6 = Channel A Bit 7 = Channel B</p>
<p>412 Reference Mask [Ref Mask]</p> <p>Ref Mask controls which ports can select an alternate reference or preset speed.</p>	<p>Parameter Number 412 Parameter Type Read/Write, Non-Linkable Sink Display Units / Drive Units Bits Factory Default 0 Minimum Value 0 Maximum Value 0FE Hex File – Group Communication I/O – SCANport Masks Enums Bit 1 = Port 1 Bit 2 = Port 2 Bit 3 = Port 3 Bit 4 = Port 4 Bit 5 = Port 5 Bit 6 = Channel A Bit 7 = Channel B</p>

<p>413 Clear Fault Mask [Clr Fault Mask]</p> <p>Clr Fault Mask controls which ports can generate a clear fault command.</p>	<p>Parameter Number 413 Parameter Type Read/Write, Non-Linkable Sink Display Units / Drive Units Bits Factory Default 0 Minimum Value 0 Maximum Value 0FE Hex File – Group Communications I/O – SCANport Masks Enums Bit 1 = Port 1 Bit 2 = Port 2 Bit 3 = Port 3 Bit 4 = Port 4 Bit 5 = Port 5 Bit 6 = Channel A Bit 7 = Channel B</p>
<p>414 Reset Drive Mask [Reset Drive Mask]</p> <p>Reset Drive Mask controls which ports can reset a fault.</p>	<p>Parameter Number 414 Parameter Type Read/Write, Non-Linkable Sink Display Units / Drive Units Bits Factory Default 0 Minimum Value 0 Maximum Value 0FE Hex File – Group Communication I/O – SCANport Masks Enums Bit 1 = Port 1 Bit 2 = Port 2 Bit 3 = Port 3 Bit 4 = Port 4 Bit 5 = Port 5 Bit 6 = Channel A Bit 7 = Channel B</p>
<p>415 Local Mask [Local Mask]</p> <p>Local Mask controls which ports are allowed to take exclusive control of drive logic commands except Stop. (Stop is accepted from any device regardless of who has control.) You can only take exclusive local control while the drive is stopped.</p>	<p>Parameter Number 415 Parameter Type Read/Write, Non-Linkable Sink Display Units / Drive Units Bits Factory Default 0 Minimum Value 0 Maximum Value 0FE Hex File – Group Communications I/O – SCANport Owners Enums Bit 1 = Port 1 Bit 2 = Port 2 Bit 3 = Port 3 Bit 4 = Port 4 Bit 5 = Port 5 Bit 6 = Channel A Bit 7 = Channel B</p>
<p>416 SCANport Default Reference [SP Default Ref]</p> <p>SP Default Ref defines the default reference to be used when the drive is powered up. You can change the value of this parameter, but the change is only accessed when the drive is powered up.</p>	<p>Parameter Number 416 Parameter Type Read/Write, Non-Linkable Sink Display Units / Drive Units None Factory Default 2 Minimum Value 1 Maximum Value 7 File – Group Velocity Torque – Velocity Ref Enums Bit 1 = Xref1 Bit 2 = Preset1 Bit 3 = Preset2 Bit 4 = Preset3 Bit 5 = Preset4 Bit 6 = Preset5 Bit 7 = Xref2</p>

425 ICN Fault Select

[ICN Flt Sel]

ICN Flt Sel dictates whether the ControlNet Adapter Board will report a fault condition if a PLC controller communications fault occurs.

If bit is one, the condition is reported as a soft fault.
If a bit is zero, parameter 426 is checked to see whether a warning condition should be reported.

Parameter Number 425
Parameter Type Read/Write, Non-Linkable Sink
Display Units / Drive Units Bits
Factory Default 47 (2Fh)
Minimum Value 0
Maximum Value 127 (7Fh)
File - Group Diagnostics - Fault Select/Status
 Communication I/O - Fault Select/Status

When adapter is used:

Enums	Bits 7-4	Bit 3	Bit 2	Bit 1	Bit 0
					Res/Pgm/Test (Flt 36023) 0 = No drive soft fault 1 = Drive soft fault
					Last State 0 = Data zeroed 1 = Continue Operation Using Last State
					ICN Comm Loss (Flt 36021) 0 = No drive soft fault 1 = Drive soft fault
					Class 1 Close 0 = No drive soft fault 1 = Drive soft fault
					Bit 4: Class 3 Close 0 = No drive soft fault 1 = Drive soft fault
					Bit 5: Class 1 Timeout 0 = No drive soft fault 1 = Drive soft fault
					Bit 6: Class 3 Timeout 0 = No drive soft fault 1 = Drive soft fault
					Bit 7: Reserved

426 ICN WarningSelect

[ICN Warn Sel]

ICN Warn Sel dictates whether the ControlNet Adapter Board will report a warning condition if a PLC controller communications fault occurs.

If a bit is one and the corresponding bit in parameter 425 is zero, then the condition is reported as a warning.

If a bit is zero and the corresponding bit in parameter 425 is zero, then the condition is ignored.

Parameter Number 426
Parameter Type Read/Write, Non-Linkable Sink
Display Units / Drive Units Bits
Factory Default 47 (2Fh)
Minimum Value 0
Maximum Value 127 (7Fh)
File - Group Diagnostics - Fault Select/Status
 Communication I/O - Fault Select/Status

When adapter is used:

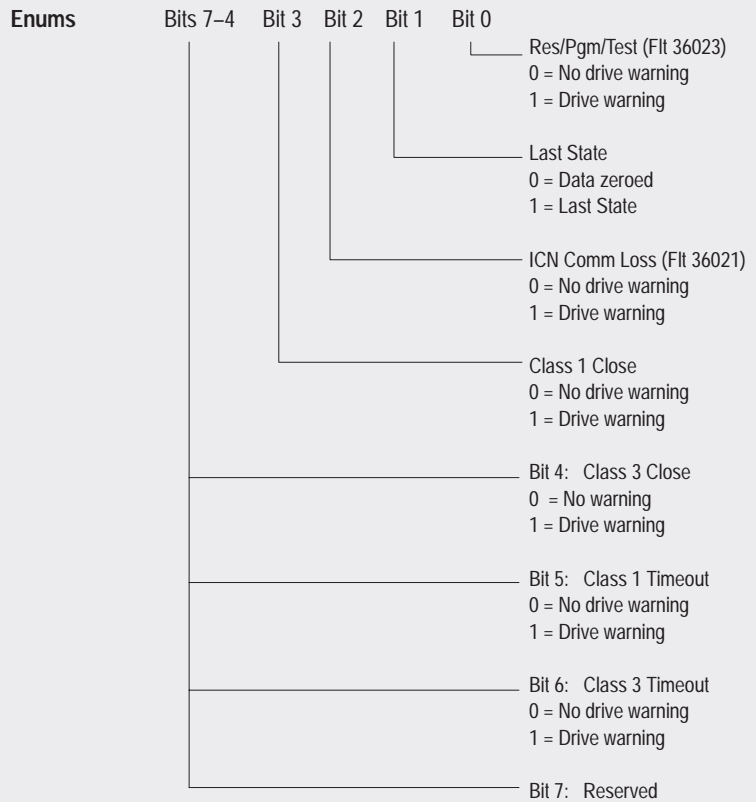

440 SCANport Fault Selection

[SP Fault Sel]

SP Fault Sel indicates which ports will cause a drive soft fault on loss of communications.

Parameter Number	440
Parameter Type	Read/Write, Sink
Display Units / Drive Units	Bits
Factory Default	0011 1110
Minimum Value	0000 0000
Maximum Value	0011 1110
File – Group	Diagnostics – Fault Select/Status Communications I/O – Fault Select/Status

Enums

Bit 7	Bit 5	Bit 4	Bit 3	Bit 2	Bit 1	Enums	Fault
						Port 1	SP P11 Timeout (Flt 26038)
						Port 2	SP P12 Timeout (Flt 26039)
						Port 3	SP P13 Timeout (Flt 26040)
						Port 4	SP P14 Timeout (Flt 26041)
						Port 5	SP P15 Timeout (Flt 26042)
							SP Offline

441 SCANport Warning Selection

[SP Warn Sel]

SP Warn Sel indicates which ports will cause a drive warning on loss of communications.

Parameter Number	441
Parameter Type	Read/Write Sink
Display Units / Drive Units	Bits
Factory Default	0011 1110
Minimum Value	0000 0000
Maximum Value	0011 1110
File – Group	Diagnostics – Fault Select/Status Communications I/O – Fault Select/Status

Enums

Bit 7	Bit 5	Bit 4	Bit 3	Bit 2	Bit 1	Enums	Warning
						Port 1	SP P11 Timeout (Flt 26038)
						Port 2	SP P12 Timeout (Flt 26039)
						Port 3	SP P13 Timeout (Flt 26040)
						Port 4	SP P14 Timeout (Flt 26041)
						Port 5	SP P15 Timeout (Flt 26042)
							SP Offline

442 SCANport Fault Status

[SP Fault Sts]

SP Fault Sts indicates which communications soft faults the drive has encountered at the ports.

Parameter Number	442
Parameter Type	Read Only, Source
Display Units / Drive Units	Bits
Factory Default	0011 1110
Minimum Value	0000 0000
Maximum Value	0011 1110
File – Group	Diagnostics – Fault Select/Status Communications I/O – Fault Select/Status

Enums

Bit 7	Bit 5	Bit 4	Bit 3	Bit 2	Bit 1	Enums	Fault
						Port 1	SP P11 Timeout (Flt 26038)
						Port 2	SP P12 Timeout (Flt 26039)
						Port 3	SP P13 Timeout (Flt 26040)
						Port 4	SP P14 Timeout (Flt 26041)
						Port 5	SP P15 Timeout (Flt 26042)
							SP Offline

443 SCANport Warning Status

[SP Warn Sts]

SP Warn Sts indicates which communications warnings the drive has encountered at the ports.

Parameter Number	443
Parameter Type	Read Only, Source
Display Units / Drive Units	Bits
Factory Default	0011 1110
Minimum Value	0000 0000
Maximum Value	0011 1110
File – Group	Diagnostics – Fault Select/Status Communications I/O – Fault Select/Status

Enums

Bit 7	Bit 5	Bit 4	Bit 3	Bit 2	Bit 1	Enums	Warning
						Port 1	SP P11 Timeout (Flt 26038)
						Port 2	SP P12 Timeout (Flt 26039)
						Port 3	SP P13 Timeout (Flt 26040)
						Port 4	SP P14 Timeout (Flt 26041)
						Port 5	SP P15 Timeout (Flt 26042)
							SP Offline

454 Trend Input 1

[Trend In 1]

Trend In 1 specifies the data value to sample at the specified trend sample rate. You should link Trend In 1 to a source parameter (such as velocity, torque, or current) for the trend to make sense.

Parameter Number	454
Parameter Type	Read/Write, Sink
Display Units / Drive Units	Dependent on Link ^①
Factory Default	0
Minimum Value	-32767 ^①
Maximum Value	+32767 ^①
File – Group	Diagnostics – Trend I/O

^① These values depend on the source parameter that this parameter is linked to. For example, if the source parameter's drive units are rpm, then Trend In 1's drive units will be displayed in rpm. The minimum and maximum values are also link dependent.

455 Trend 1 Operand Parameter X

[Tr1 Opnd Parm X]

Tr1 Opnd Parm X specifies the first of two parameter numbers for the trend trigger evaluation. The data value for the entered link parameter number is used in the trigger evaluation.

Parameter Number	455
Parameter Type	Read/Write, Sink
Display Units / Drive Units	Dependent on Link ^①
Factory Default	0
Minimum Value	-32767 ^①
Maximum Value	+32767 ^①
File – Group	Diagnostics – Trend Setup

^① These values depend on the source parameter that this parameter is linked to. For example, if the source parameter's drive units are rpm, then Tr1 Opnd Parm X's drive units will be displayed in rpm. The minimum and maximum values are also link dependent.

456 Trend 1 Operand Parameter Y [Tr1 Opnd Parm Y]	Parameter Number	456
	Parameter Type	Read/Write, Sink
Tr1 Opnd Parm Y specifies the second of two parameter numbers used for the trend trigger evaluation. The data value for the entered link parameter number is used in the trigger evaluation.	Display Units / Drive Units	Dependent on Link ^①
	Factory Default	0
	Minimum Value	-32767 ^①
	Maximum Value	+32767 ^①
	File – Group	Diagnostics – Trend Setup
	^① These values depend on the source parameter that this parameter is linked to. For example, if the source parameter's drive units are rpm, then Tr1 Opnd Parm Y's drive units will be displayed in rpm. The minimum and maximum values are also link dependent.	

457 Trend 1 Operator [Tr1 Operator]	Parameter Number	457	
	Parameter Type	Read/Write, Non-Linkable Sink	
Tr 1 Operator specifies the operator used for the trend trigger evaluation. The available operators are:	Display Units / Drive Units	None	
	Factory Default	5	
	Minimum Value	1	
	Maximum Value	8	
	File – Group	Diagnostics – Trend Setup	
	Value	Description	
	1	Greater Than (.GT.)	
2	Less Than (.LT.)		
3	Equals (.EQ.)		
4	Not Equals (.NE.)		
5	Logical AND (.AND.)		
6	Logical NAND (.NAND.)		
7	Logical OR (.OR.)		
8	Logical NOR (.NOR.)		

458 Trend 1 Sample Rate [Tr1 Sample Rate]	Parameter Number	458
	Parameter Type	Read/Write, Non-Linkable Sink
Tr1 Sample Rate specifies the interval at which the data in the Trend In 1 parameter is sampled. It is programmable in 2 millisecond increments. All values are rounded down to the nearest 2 millisecond interval.	Display Units / Drive Units	Seconds
	Factory Default	0.020 Seconds
	Minimum Value	0.002 Seconds
	Maximum Value	30 Seconds
	File – Group	Diagnostics – Trend Setup

459 Trend 1 Post Samples [Tr1 Post Samples]	Parameter Number	459
	Parameter Type	Read/Write, Non-Linkable Sink
Tr1 Post Samples specifies the number of data samples to be gathered once the trigger evaluation becomes true. There is always a sample reserved for the instance when the trigger condition becomes true.	Display Units / Drive Units	None
	Factory Default	15
	Minimum Value	0
	Maximum Value	499
	File – Group	Diagnostics – Trend Setup

<p>460 Trend 1 Continuous Trigger [Tr1 Cont Trigger]</p> <p>Tr1 Cont Trigger specifies the type of trend. You can choose either 0 for one-shot or 1 for continuous.</p> <p>With a one-shot trend, once the trigger condition is true and the number of samples after the trigger is taken are gathered, the trend stops.</p> <p>With a continuous trend, once the trigger condition is true and the number of samples after the trigger is taken are gathered, the trend continues looking for the next occurrence of a true trigger condition.</p>	<table border="0"> <tr><td>Parameter Number</td><td>460</td></tr> <tr><td>Parameter Type</td><td>Read/Write, Non-Linkable Sink</td></tr> <tr><td>Display Units / Drive Units</td><td>None</td></tr> <tr><td>Factory Default</td><td>0</td></tr> <tr><td>Minimum Value</td><td>0</td></tr> <tr><td>Maximum Value</td><td>1</td></tr> <tr><td>File - Group</td><td>Diagnostics - Trend Setup</td></tr> </table>	Parameter Number	460	Parameter Type	Read/Write, Non-Linkable Sink	Display Units / Drive Units	None	Factory Default	0	Minimum Value	0	Maximum Value	1	File - Group	Diagnostics - Trend Setup		
Parameter Number	460																
Parameter Type	Read/Write, Non-Linkable Sink																
Display Units / Drive Units	None																
Factory Default	0																
Minimum Value	0																
Maximum Value	1																
File - Group	Diagnostics - Trend Setup																
<p>461 Trend 1 Select [Tr1 Select]</p> <p>Tr1 Select specifies the trend mode. The states are as follows:</p> <ul style="list-style-type: none"> 0 Disable the trend. 1 Enable the trend. 2 Force a true trigger condition. 	<table border="0"> <tr><td>Parameter Number</td><td>461</td></tr> <tr><td>Parameter Type</td><td>Read/Write, Non-Linkable Sink</td></tr> <tr><td>Display Units / Drive Units</td><td>None</td></tr> <tr><td>Factory Default</td><td>0</td></tr> <tr><td>Minimum Value</td><td>0</td></tr> <tr><td>Maximum Value</td><td>2</td></tr> <tr><td>File - Group</td><td>Diagnostics - Trend Setup</td></tr> <tr><td>Enums</td><td>0 = Disable 1 = Enable 2 = Force Trig</td></tr> </table>	Parameter Number	461	Parameter Type	Read/Write, Non-Linkable Sink	Display Units / Drive Units	None	Factory Default	0	Minimum Value	0	Maximum Value	2	File - Group	Diagnostics - Trend Setup	Enums	0 = Disable 1 = Enable 2 = Force Trig
Parameter Number	461																
Parameter Type	Read/Write, Non-Linkable Sink																
Display Units / Drive Units	None																
Factory Default	0																
Minimum Value	0																
Maximum Value	2																
File - Group	Diagnostics - Trend Setup																
Enums	0 = Disable 1 = Enable 2 = Force Trig																
<p>462 Trend 1 Status [Tr1 Status]</p> <p>Tr1 Status identifies which state the trend is currently in. The following states are possible:</p> <ul style="list-style-type: none"> 1 Stopped Trending is not executing. 2 Running Trending is executing, but the trigger point has not yet been reached. 3 Tripped/Trigger Trending is executing, and the trigger point has been reached. 4 Tripped/Forced The trigger point was forced. 	<table border="0"> <tr><td>Parameter Number</td><td>462</td></tr> <tr><td>Parameter Type</td><td>Read Only, Non-Linkable Source</td></tr> <tr><td>Display Units / Drive Units</td><td>None</td></tr> <tr><td>Factory Default</td><td>1</td></tr> <tr><td>Minimum Value</td><td>1</td></tr> <tr><td>Maximum Value</td><td>4</td></tr> <tr><td>File - Group</td><td>Diagnostics - Trend I/O</td></tr> <tr><td>Enums</td><td>1 = Stopped 2 = Running 3 = Trip Trig 4 = Force Trip</td></tr> </table>	Parameter Number	462	Parameter Type	Read Only, Non-Linkable Source	Display Units / Drive Units	None	Factory Default	1	Minimum Value	1	Maximum Value	4	File - Group	Diagnostics - Trend I/O	Enums	1 = Stopped 2 = Running 3 = Trip Trig 4 = Force Trip
Parameter Number	462																
Parameter Type	Read Only, Non-Linkable Source																
Display Units / Drive Units	None																
Factory Default	1																
Minimum Value	1																
Maximum Value	4																
File - Group	Diagnostics - Trend I/O																
Enums	1 = Stopped 2 = Running 3 = Trip Trig 4 = Force Trip																
<p>463 Trend Output 1 [Trend Out 1]</p> <p>Trend Out 1 displays the latest 500 trend input data values once the trigger condition is true and all post samples are gathered. This parameter is updated at the same rate as the data was sampled. This parameter can be linked to Analog Output (for example) and a chart recorder connected to Analog Output to provide a hard copy of the trend data.</p>	<table border="0"> <tr><td>Parameter Number</td><td>463</td></tr> <tr><td>Parameter Type</td><td>Read Only, Source</td></tr> <tr><td>Display Units / Drive Units</td><td>None</td></tr> <tr><td>Factory Default</td><td>0</td></tr> <tr><td>Minimum Value</td><td>-32767</td></tr> <tr><td>Maximum Value</td><td>+32767</td></tr> <tr><td>File - Group</td><td>Diagnostics - Trend I/O</td></tr> </table>	Parameter Number	463	Parameter Type	Read Only, Source	Display Units / Drive Units	None	Factory Default	0	Minimum Value	-32767	Maximum Value	+32767	File - Group	Diagnostics - Trend I/O		
Parameter Number	463																
Parameter Type	Read Only, Source																
Display Units / Drive Units	None																
Factory Default	0																
Minimum Value	-32767																
Maximum Value	+32767																
File - Group	Diagnostics - Trend I/O																

<p>464 Trend Input 2 [Trend In 2]</p> <p>Trend In 2 specifies the data value to sample at the specified trend sample rate. You should link Trend In 2 to a source parameter (such as velocity, torque, or current) for the trend to make sense.</p>	<table border="0"> <tr><td>Parameter Number</td><td>464</td></tr> <tr><td>Parameter Type</td><td>Read/Write, Sink</td></tr> <tr><td>Display Units / Drive Units</td><td>Dependent on Link①</td></tr> <tr><td>Factory Default</td><td>0</td></tr> <tr><td>Minimum Value</td><td>-32767①</td></tr> <tr><td>Maximum Value</td><td>+32767①</td></tr> <tr><td>File – Group</td><td>Diagnostics – Trend I/O</td></tr> </table> <p>① These values depend on the source parameter that this parameter is linked to. For example, if the source parameter's drive units are rpm, then Trend In 2's drive units will be displayed in rpm. The minimum and maximum values are also link dependent.</p>	Parameter Number	464	Parameter Type	Read/Write, Sink	Display Units / Drive Units	Dependent on Link①	Factory Default	0	Minimum Value	-32767①	Maximum Value	+32767①	File – Group	Diagnostics – Trend I/O																		
Parameter Number	464																																
Parameter Type	Read/Write, Sink																																
Display Units / Drive Units	Dependent on Link①																																
Factory Default	0																																
Minimum Value	-32767①																																
Maximum Value	+32767①																																
File – Group	Diagnostics – Trend I/O																																
<p>465 Trend 2 Operand Parameter X [Tr2 Opnd Parm X]</p> <p>Tr2 Opnd Parm X specifies the first of two parameter numbers for the trend trigger evaluation. The data value for the entered link parameter number is used in the trigger evaluation.</p>	<table border="0"> <tr><td>Parameter Number</td><td>465</td></tr> <tr><td>Parameter Type</td><td>Read/Write, Sink</td></tr> <tr><td>Display Units / Drive Units</td><td>Dependent on Link①</td></tr> <tr><td>Factory Default</td><td>0</td></tr> <tr><td>Minimum Value</td><td>-32767①</td></tr> <tr><td>Maximum Value</td><td>+32767①</td></tr> <tr><td>File – Group</td><td>Diagnostics – Trend Setup</td></tr> </table> <p>① These values depend on the source parameter that this parameter is linked to. For example, if the source parameter's drive units are rpm, then Tr2 Opnd Parm X's drive units will be displayed in rpm. The minimum and maximum values are also link dependent.</p>	Parameter Number	465	Parameter Type	Read/Write, Sink	Display Units / Drive Units	Dependent on Link①	Factory Default	0	Minimum Value	-32767①	Maximum Value	+32767①	File – Group	Diagnostics – Trend Setup																		
Parameter Number	465																																
Parameter Type	Read/Write, Sink																																
Display Units / Drive Units	Dependent on Link①																																
Factory Default	0																																
Minimum Value	-32767①																																
Maximum Value	+32767①																																
File – Group	Diagnostics – Trend Setup																																
<p>466 Trend 2 Operand Parameter Y [Tr2 Opnd Parm Y]</p> <p>Tr2 Opnd Parm Y specifies the second of two parameter numbers used for the trend trigger evaluation. The data value for the entered link parameter number is used in the trigger evaluation.</p>	<table border="0"> <tr><td>Parameter Number</td><td>466</td></tr> <tr><td>Parameter Type</td><td>Read/Write, Sink</td></tr> <tr><td>Display Units / Drive Units</td><td>Dependent on Link①</td></tr> <tr><td>Factory Default</td><td>0</td></tr> <tr><td>Minimum Value</td><td>-32767①</td></tr> <tr><td>Maximum Value</td><td>+32767①</td></tr> <tr><td>File – Group</td><td>Diagnostics – Trend Setup</td></tr> </table> <p>① These values depend on the source parameter that this parameter is linked to. For example, if the source parameter's drive units are rpm, then Tr2 Opnd Parm Y's drive units will be displayed in rpm. The minimum and maximum values are also link dependent.</p>	Parameter Number	466	Parameter Type	Read/Write, Sink	Display Units / Drive Units	Dependent on Link①	Factory Default	0	Minimum Value	-32767①	Maximum Value	+32767①	File – Group	Diagnostics – Trend Setup																		
Parameter Number	466																																
Parameter Type	Read/Write, Sink																																
Display Units / Drive Units	Dependent on Link①																																
Factory Default	0																																
Minimum Value	-32767①																																
Maximum Value	+32767①																																
File – Group	Diagnostics – Trend Setup																																
<p>467 Trend 2 Operator [Tr2 Operator]</p> <p>Tr2 Operator specifies the operator used for the trend trigger evaluation. The available operators are:</p> <table border="1"> <thead> <tr> <th>Value</th> <th>Description</th> </tr> </thead> <tbody> <tr><td>1</td><td>Greater Than (.GT.)</td></tr> <tr><td>2</td><td>Less Than (.LT.)</td></tr> <tr><td>3</td><td>Equals (.EQ.)</td></tr> <tr><td>4</td><td>Not Equals (.NE.)</td></tr> <tr><td>5</td><td>Logical AND (.AND.)</td></tr> <tr><td>6</td><td>Logical NAND (.NAND.)</td></tr> <tr><td>7</td><td>Logical OR (.OR.)</td></tr> <tr><td>8</td><td>Logical NOR (.NOR.)</td></tr> </tbody> </table>	Value	Description	1	Greater Than (.GT.)	2	Less Than (.LT.)	3	Equals (.EQ.)	4	Not Equals (.NE.)	5	Logical AND (.AND.)	6	Logical NAND (.NAND.)	7	Logical OR (.OR.)	8	Logical NOR (.NOR.)	<table border="0"> <tr><td>Parameter Number</td><td>467</td></tr> <tr><td>Parameter Type</td><td>Read/Write, Non-Linkable Sink</td></tr> <tr><td>Display Units / Drive Units</td><td>None</td></tr> <tr><td>Factory Default</td><td>5</td></tr> <tr><td>Minimum Value</td><td>1</td></tr> <tr><td>Maximum Value</td><td>8</td></tr> <tr><td>File – Group</td><td>Diagnostics – Trend Setup</td></tr> </table>	Parameter Number	467	Parameter Type	Read/Write, Non-Linkable Sink	Display Units / Drive Units	None	Factory Default	5	Minimum Value	1	Maximum Value	8	File – Group	Diagnostics – Trend Setup
Value	Description																																
1	Greater Than (.GT.)																																
2	Less Than (.LT.)																																
3	Equals (.EQ.)																																
4	Not Equals (.NE.)																																
5	Logical AND (.AND.)																																
6	Logical NAND (.NAND.)																																
7	Logical OR (.OR.)																																
8	Logical NOR (.NOR.)																																
Parameter Number	467																																
Parameter Type	Read/Write, Non-Linkable Sink																																
Display Units / Drive Units	None																																
Factory Default	5																																
Minimum Value	1																																
Maximum Value	8																																
File – Group	Diagnostics – Trend Setup																																

<p>468 Trend 2 Sample Rate [Tr2 Sample Rate]</p> <p>Trend 2 Sample Rate specifies the interval at which the data in the Trend In 2 parameter is sampled. It is programmable in 2 millisecond increments. All values are rounded down to the nearest 2 millisecond interval.</p>	<table border="0"> <tr><td>Parameter Number</td><td>468</td></tr> <tr><td>Parameter Type</td><td>Read/Write, Non-Linkable Sink</td></tr> <tr><td>Display Units / Drive Units</td><td>Seconds</td></tr> <tr><td>Factory Default</td><td>0.020 Seconds</td></tr> <tr><td>Minimum Value</td><td>0.002 Seconds</td></tr> <tr><td>Maximum Value</td><td>30 Seconds</td></tr> <tr><td>File - Group</td><td>Diagnostics - Trend Setup</td></tr> </table>	Parameter Number	468	Parameter Type	Read/Write, Non-Linkable Sink	Display Units / Drive Units	Seconds	Factory Default	0.020 Seconds	Minimum Value	0.002 Seconds	Maximum Value	30 Seconds	File - Group	Diagnostics - Trend Setup		
Parameter Number	468																
Parameter Type	Read/Write, Non-Linkable Sink																
Display Units / Drive Units	Seconds																
Factory Default	0.020 Seconds																
Minimum Value	0.002 Seconds																
Maximum Value	30 Seconds																
File - Group	Diagnostics - Trend Setup																
<p>469 Trend 2 Post Samples [Tr2 Post Samples]</p> <p>Tr2 Post Samples specifies the number of data samples to be gathered once the trigger evaluation becomes true. There is always a sample reserved for the instance when the trigger condition becomes true.</p>	<table border="0"> <tr><td>Parameter Number</td><td>469</td></tr> <tr><td>Parameter Type</td><td>Read/Write, Non-Linkable Sink</td></tr> <tr><td>Display Units / Drive Units</td><td>None</td></tr> <tr><td>Factory Default</td><td>15</td></tr> <tr><td>Minimum Value</td><td>0</td></tr> <tr><td>Maximum Value</td><td>499</td></tr> <tr><td>File - Group</td><td>Diagnostics - Trend Setup</td></tr> </table>	Parameter Number	469	Parameter Type	Read/Write, Non-Linkable Sink	Display Units / Drive Units	None	Factory Default	15	Minimum Value	0	Maximum Value	499	File - Group	Diagnostics - Trend Setup		
Parameter Number	469																
Parameter Type	Read/Write, Non-Linkable Sink																
Display Units / Drive Units	None																
Factory Default	15																
Minimum Value	0																
Maximum Value	499																
File - Group	Diagnostics - Trend Setup																
<p>470 Trend 2 Continuous Trigger [Tr2 Cont Trigger]</p> <p>Tr2 Cont Trigger specifies the type of trend. You can choose either 0 for one-shot or for continuous.</p> <p>With a one-shot trend, once the trigger condition is true and the number of samples after the trigger is taken are gathered, the trend stops.</p> <p>With a continuous trend, once the trigger condition is true and the number of samples after the trigger is taken are gathered, the trend continues looking for the next occurrence of a true trigger condition.</p>	<table border="0"> <tr><td>Parameter Number</td><td>470</td></tr> <tr><td>Parameter Type</td><td>Read/Write, Non-Linkable Sink</td></tr> <tr><td>Display Units / Drive Units</td><td>None</td></tr> <tr><td>Factory Default</td><td>0</td></tr> <tr><td>Minimum Value</td><td>0</td></tr> <tr><td>Maximum Value</td><td>1</td></tr> <tr><td>File - Group</td><td>Diagnostics - Trend Setup</td></tr> </table>	Parameter Number	470	Parameter Type	Read/Write, Non-Linkable Sink	Display Units / Drive Units	None	Factory Default	0	Minimum Value	0	Maximum Value	1	File - Group	Diagnostics - Trend Setup		
Parameter Number	470																
Parameter Type	Read/Write, Non-Linkable Sink																
Display Units / Drive Units	None																
Factory Default	0																
Minimum Value	0																
Maximum Value	1																
File - Group	Diagnostics - Trend Setup																
<p>471 Trend 2 Select [Tr2 Select]</p> <p>Tr2 Select specifies the trend mode. The states are as follows:</p> <ul style="list-style-type: none"> 0 Disable the trend. 1 Enable the trend. 2 Force a true trigger condition. 	<table border="0"> <tr><td>Parameter Number</td><td>471</td></tr> <tr><td>Parameter Type</td><td>Read/Write, Non-Linkable Sink</td></tr> <tr><td>Display Units / Drive Units</td><td>None</td></tr> <tr><td>Factory Default</td><td>0</td></tr> <tr><td>Minimum Value</td><td>0</td></tr> <tr><td>Maximum Value</td><td>2</td></tr> <tr><td>File - Group</td><td>Diagnostics - Trend Setup</td></tr> <tr><td>Enums</td><td>0 = Disable 1 = Enable 2 = Force Trig</td></tr> </table>	Parameter Number	471	Parameter Type	Read/Write, Non-Linkable Sink	Display Units / Drive Units	None	Factory Default	0	Minimum Value	0	Maximum Value	2	File - Group	Diagnostics - Trend Setup	Enums	0 = Disable 1 = Enable 2 = Force Trig
Parameter Number	471																
Parameter Type	Read/Write, Non-Linkable Sink																
Display Units / Drive Units	None																
Factory Default	0																
Minimum Value	0																
Maximum Value	2																
File - Group	Diagnostics - Trend Setup																
Enums	0 = Disable 1 = Enable 2 = Force Trig																
<p>472 Trend 2 Status [Tr2 Status]</p> <p>Tr2 Status identifies which state the trend is currently in. The following states are possible:</p> <ul style="list-style-type: none"> 1 Stopped Trending is not executing. 2 Running Trending is executing, but the trigger point has not yet been reached. 3 Tripped/Trigger Trending is executing, and the trigger point has been reached. 4 Tripped/Forced The trigger point was forced. 	<table border="0"> <tr><td>Parameter Number</td><td>472</td></tr> <tr><td>Parameter Type</td><td>Read Only, Non-Linkable Source</td></tr> <tr><td>Display Units / Drive Units</td><td>None</td></tr> <tr><td>Factory Default</td><td>1</td></tr> <tr><td>Minimum Value</td><td>1</td></tr> <tr><td>Maximum Value</td><td>4</td></tr> <tr><td>File - Group</td><td>Diagnostics - Trend I/O</td></tr> <tr><td>Enums</td><td>1 = Stopped 2 = Running 3 = Trip Trig 4 = Force Trip</td></tr> </table>	Parameter Number	472	Parameter Type	Read Only, Non-Linkable Source	Display Units / Drive Units	None	Factory Default	1	Minimum Value	1	Maximum Value	4	File - Group	Diagnostics - Trend I/O	Enums	1 = Stopped 2 = Running 3 = Trip Trig 4 = Force Trip
Parameter Number	472																
Parameter Type	Read Only, Non-Linkable Source																
Display Units / Drive Units	None																
Factory Default	1																
Minimum Value	1																
Maximum Value	4																
File - Group	Diagnostics - Trend I/O																
Enums	1 = Stopped 2 = Running 3 = Trip Trig 4 = Force Trip																

<p>473 Trend Output 2 [Trend Out 2]</p> <p>Trend Out 2 displays the latest 500 trend input data values once the trigger condition is true and all post samples are gathered. This parameter is updated at the same rate as the data was sampled. This parameter can be linked to Analog Output (for example) and a chart recorder connected to Analog Output to provide a hard copy of the trend data.</p>	<table border="0"> <tr><td>Parameter Number</td><td>473</td></tr> <tr><td>Parameter Type</td><td>Read Only, Source</td></tr> <tr><td>Display Units / Drive Units</td><td>None</td></tr> <tr><td>Factory Default</td><td>0</td></tr> <tr><td>Minimum Value</td><td>-32767</td></tr> <tr><td>Maximum Value</td><td>+32767</td></tr> <tr><td>File – Group</td><td>Diagnostics – Trend I/O</td></tr> </table>	Parameter Number	473	Parameter Type	Read Only, Source	Display Units / Drive Units	None	Factory Default	0	Minimum Value	-32767	Maximum Value	+32767	File – Group	Diagnostics – Trend I/O
Parameter Number	473														
Parameter Type	Read Only, Source														
Display Units / Drive Units	None														
Factory Default	0														
Minimum Value	-32767														
Maximum Value	+32767														
File – Group	Diagnostics – Trend I/O														
<p>474 Trend Input 3 [Trend In 3]</p> <p>Trend In 3 specifies the data value to sample at the specified trend sample rate. You should link Trend In 3 to a source parameter (such as velocity, torque, or current) for the trend to make sense.</p>	<table border="0"> <tr><td>Parameter Number</td><td>474</td></tr> <tr><td>Parameter Type</td><td>Read/Write, Sink</td></tr> <tr><td>Display Units / Drive Units</td><td>Dependent on Link①</td></tr> <tr><td>Factory Default</td><td>0</td></tr> <tr><td>Minimum Value</td><td>-32767①</td></tr> <tr><td>Maximum Value</td><td>+32767①</td></tr> <tr><td>File – Group</td><td>Diagnostics – Trend I/O</td></tr> </table> <p>① These values depend on the source parameter that this parameter is linked to. For example, if the source parameter's drive units are rpm, then Trend In 3's drive units will be displayed in rpm. The minimum and maximum values are also link dependent.</p>	Parameter Number	474	Parameter Type	Read/Write, Sink	Display Units / Drive Units	Dependent on Link①	Factory Default	0	Minimum Value	-32767①	Maximum Value	+32767①	File – Group	Diagnostics – Trend I/O
Parameter Number	474														
Parameter Type	Read/Write, Sink														
Display Units / Drive Units	Dependent on Link①														
Factory Default	0														
Minimum Value	-32767①														
Maximum Value	+32767①														
File – Group	Diagnostics – Trend I/O														
<p>475 Trend 3 Operand Parameter X [Tr3 Opnd Parm X]</p> <p>Tr3 Opnd Parm X specifies the first of two parameter numbers for the trend trigger evaluation. The data value for the entered link parameter number is used in the trigger evaluation.</p>	<table border="0"> <tr><td>Parameter Number</td><td>475</td></tr> <tr><td>Parameter Type</td><td>Read/Write, Sink</td></tr> <tr><td>Display Units / Drive Units</td><td>Dependent on Link①</td></tr> <tr><td>Factory Default</td><td>0</td></tr> <tr><td>Minimum Value</td><td>-32767①</td></tr> <tr><td>Maximum Value</td><td>+32767①</td></tr> <tr><td>File – Group</td><td>Diagnostics – Trend Setup</td></tr> </table> <p>① These values depend on the source parameter that this parameter is linked to. For example, if the source parameter's drive units are rpm, then Tr3 Opnd Parm X's drive units will be displayed in rpm. The minimum and maximum values are also link dependent.</p>	Parameter Number	475	Parameter Type	Read/Write, Sink	Display Units / Drive Units	Dependent on Link①	Factory Default	0	Minimum Value	-32767①	Maximum Value	+32767①	File – Group	Diagnostics – Trend Setup
Parameter Number	475														
Parameter Type	Read/Write, Sink														
Display Units / Drive Units	Dependent on Link①														
Factory Default	0														
Minimum Value	-32767①														
Maximum Value	+32767①														
File – Group	Diagnostics – Trend Setup														
<p>476 Trend 3 Operand Parameter Y [Tr3 Opnd Parm Y]</p> <p>Tr3 Opnd Parm Y specifies the second of two parameter numbers used for the trend trigger evaluation. The data value for the entered link parameter number is used in the trigger evaluation.</p>	<table border="0"> <tr><td>Parameter Number</td><td>476</td></tr> <tr><td>Parameter Type</td><td>Read/Write, Sink</td></tr> <tr><td>Display Units / Drive Units</td><td>Dependent on Link①</td></tr> <tr><td>Factory Default</td><td>0</td></tr> <tr><td>Minimum Value</td><td>-32767①</td></tr> <tr><td>Maximum Value</td><td>+32767①</td></tr> <tr><td>File – Group</td><td>Diagnostics – Trend Setup</td></tr> </table> <p>① These values depend on the source parameter that this parameter is linked to. For example, if the source parameter's drive units are rpm, then Tr3 Opnd Parm Y's drive units will be displayed in rpm. The minimum and maximum values are also link dependent.</p>	Parameter Number	476	Parameter Type	Read/Write, Sink	Display Units / Drive Units	Dependent on Link①	Factory Default	0	Minimum Value	-32767①	Maximum Value	+32767①	File – Group	Diagnostics – Trend Setup
Parameter Number	476														
Parameter Type	Read/Write, Sink														
Display Units / Drive Units	Dependent on Link①														
Factory Default	0														
Minimum Value	-32767①														
Maximum Value	+32767①														
File – Group	Diagnostics – Trend Setup														

477 Trend 3 Operator

[Tr3 Operator]

Tr3 Operator specifies the operator used for the trend trigger evaluation. The available operators are:

Value	Description
1	Greater Than (.GT.)
2	Less Than (.LT.)
3	Equals (.EQ.)
4	Not Equals (.NE.)
5	Logical AND (.AND.)
6	Logical NAND (.NAND.)
7	Logical OR (.OR.)
8	Logical NOR (.NOR.)

Parameter Number	477
Parameter Type	Read/Write, Non-Linkable Sink
Display Units / Drive Units	None
Factory Default	5
Minimum Value	1
Maximum Value	8
File - Group	Diagnostics - Trend Setup

478 Trend 3 Sample Rate

[Tr3 Sample Rate]

Tr3 Sample Rate specifies the interval at which the data in the Trend In 3 parameter is sampled. It is programmable in 2 millisecond increments. All values are rounded down to the nearest 2 millisecond interval.

Parameter Number	478
Parameter Type	Read/Write, Non-Linkable Sink
Display Units / Drive Units	Seconds
Factory Default	0.020 Seconds
Minimum Value	0.002 Seconds
Maximum Value	30 Seconds
File - Group	Diagnostics - Trend Setup

479 Trend 3 Post Samples

[Tr3 Post Samples]

Tr3 Post Samples specifies the number of data samples to be gathered once the trigger evaluation becomes true. There is always a sample reserved for the instance when the trigger condition becomes true.

Parameter Number	479
Parameter Type	Read/Write, Non-Linkable Sink
Display Units / Drive Units	None
Factory Default	15
Minimum Value	0
Maximum Value	499
File - Group	Diagnostics - Trend Setup

480 Trend 3 Continuous Trigger

[Tr3 Cont Trigger]

Tr3 Cont Trigger specifies the type of trend. You can choose either 0 for one-shot or 1 for continuous.

With a one-shot trend, once the trigger condition is true and the number of samples after the trigger is taken are gathered, the trend stops.

With a continuous trend, once the trigger condition is true and the number of samples after the trigger is taken are gathered, the trend continues looking for the next occurrence of a true trigger condition.

Parameter Number	480
Parameter Type	Read/Write, Non-Linkable Sink
Display Units / Drive Units	None
Factory Default	0
Minimum Value	0
Maximum Value	1
File - Group	Diagnostics - Trend Setup

481 Trend 3 Select [Tr3 Select]	Parameter Number	481
	Parameter Type	Read/Write, Non-Linkable Sink
Tr3 Select specifies the trend mode. The states are as follows: 0 Disable the trend. 1 Enable the trend. 2 Force a true trigger condition.	Display Units / Drive Units	None
	Factory Default	0
	Minimum Value	0
	Maximum Value	2
	File – Group	Diagnostics – Trend Setup
	Enums	0 = Disable 1 = Enable 2 = Force Trig

482 Trend 3 Status [Tr3 Status]	Parameter Number	482
	Parameter Type	Read Only, Non-Linkable Source
Tr3 Status identifies which state the trend is currently in. The following states are possible: 1 Stopped Trending is not executing. 2 Running Trending is executing, but the trigger point has not yet been reached. 3 Tripped/Trigger Trending is executing, and the trigger point has been reached. 4 Tripped/Forced The trigger point was forced.	Display Units / Drive Units	None
	Factory Default	1
	Minimum Value	1
	Maximum Value	4
	File – Group	Diagnostics – Trend I/O
	Enums	1 = Stopped 2 = Running 3 = Trip Trig 4 = Force Trip

483 Trend Output 3 [Trend Out 3]	Parameter Number	483
	Parameter Type	Read Only, Source
Trend Out 3 displays the latest 500 trend input data values once the trigger condition is true and all post samples are gathered. This parameter is updated at the same rate as the data was sampled. This parameter can be linked to Analog Output (for example) and a chart recorder connected to Analog Output to provide a hard copy of the trend data.	Display Units / Drive Units	None
	Factory Default	0
	Minimum Value	-32767
	Maximum Value	+32767
	File – Group	Diagnostics – Trend I/O

484 Trend Input 4 [Trend In 4]	Parameter Number	484
	Parameter Type	Read/Write, Sink
Trend In 4 specifies the data value to sample at the specified trend sample rate. You should link Trend In 4 to a source parameter (such as velocity, torque, or current) for the trend to make sense.	Display Units / Drive Units	Dependent on Link ^①
	Factory Default	0
	Minimum Value	-32767 ^①
	Maximum Value	+32767 ^①
	File – Group	Diagnostics – Trend I/O
	^① These values depend on the source parameter that this parameter is linked to. For example, if the source parameter's drive units are rpm, then Trend In 4's drive units will be displayed in rpm. The minimum and maximum values are also link dependent.	

<p>485 Trend 4 Operand Parameter X [Tr4 Opnd Parm X]</p> <p>Tr4 Opnd Parm X specifies the first of two parameter numbers for the trend trigger evaluation. The data value for the entered link parameter number is used in the trigger evaluation.</p>	<table border="0"> <tr><td>Parameter Number</td><td>485</td></tr> <tr><td>Parameter Type</td><td>Read/Write, Sink</td></tr> <tr><td>Display Units / Drive Units</td><td>Dependent on Link①</td></tr> <tr><td>Factory Default</td><td>0</td></tr> <tr><td>Minimum Value</td><td>-32767①</td></tr> <tr><td>Maximum Value</td><td>+32767①</td></tr> <tr><td>File – Group</td><td>Diagnostics – Trend Setup</td></tr> </table> <p>① These values depend on the source parameter that this parameter is linked to. For example, if the source parameter's drive units are rpm, then Tr4 Opnd Parm X's drive units will be displayed in rpm. The minimum and maximum values are also link dependent.</p>	Parameter Number	485	Parameter Type	Read/Write, Sink	Display Units / Drive Units	Dependent on Link①	Factory Default	0	Minimum Value	-32767①	Maximum Value	+32767①	File – Group	Diagnostics – Trend Setup																		
Parameter Number	485																																
Parameter Type	Read/Write, Sink																																
Display Units / Drive Units	Dependent on Link①																																
Factory Default	0																																
Minimum Value	-32767①																																
Maximum Value	+32767①																																
File – Group	Diagnostics – Trend Setup																																
<p>486 Trend 4 Operand Parameter Y [Tr4 Opnd Parm Y]</p> <p>Tr4 Opnd Parm Y specifies the second of two parameter numbers used for the trend trigger evaluation. The data value for the entered link parameter number is used in the trigger evaluation.</p>	<table border="0"> <tr><td>Parameter Number</td><td>486</td></tr> <tr><td>Parameter Type</td><td>Read/Write, Sink</td></tr> <tr><td>Display Units / Drive Units</td><td>Dependent on Link①</td></tr> <tr><td>Factory Default</td><td>0</td></tr> <tr><td>Minimum Value</td><td>-32767①</td></tr> <tr><td>Maximum Value</td><td>+32767①</td></tr> <tr><td>File – Group</td><td>Diagnostics – Trend Setup</td></tr> </table> <p>① These values depend on the source parameter that this parameter is linked to. For example, if the source parameter's drive units are rpm, then Tr4 Opnd Parm Y's drive units will be displayed in rpm. The minimum and maximum values are also link dependent.</p>	Parameter Number	486	Parameter Type	Read/Write, Sink	Display Units / Drive Units	Dependent on Link①	Factory Default	0	Minimum Value	-32767①	Maximum Value	+32767①	File – Group	Diagnostics – Trend Setup																		
Parameter Number	486																																
Parameter Type	Read/Write, Sink																																
Display Units / Drive Units	Dependent on Link①																																
Factory Default	0																																
Minimum Value	-32767①																																
Maximum Value	+32767①																																
File – Group	Diagnostics – Trend Setup																																
<p>487 Trend 4 Operator [Tr4 Operator]</p> <p>Tr4 Operator specifies the operator used for the trend trigger evaluation. The available operators are:</p> <table border="1"> <thead> <tr> <th>Value</th> <th>Description</th> </tr> </thead> <tbody> <tr><td>1</td><td>Greater Than (.GT.)</td></tr> <tr><td>2</td><td>Less Than (.LT.)</td></tr> <tr><td>3</td><td>Equals (.EQ.)</td></tr> <tr><td>4</td><td>Not Equals (.NE.)</td></tr> <tr><td>5</td><td>Logical AND (.AND.)</td></tr> <tr><td>6</td><td>Logical NAND (.NAND.)</td></tr> <tr><td>7</td><td>Logical OR (.OR.)</td></tr> <tr><td>8</td><td>Logical NOR (.NOR.)</td></tr> </tbody> </table>	Value	Description	1	Greater Than (.GT.)	2	Less Than (.LT.)	3	Equals (.EQ.)	4	Not Equals (.NE.)	5	Logical AND (.AND.)	6	Logical NAND (.NAND.)	7	Logical OR (.OR.)	8	Logical NOR (.NOR.)	<table border="0"> <tr><td>Parameter Number</td><td>487</td></tr> <tr><td>Parameter Type</td><td>Read/Write, Non-Linkable Sink</td></tr> <tr><td>Display Units / Drive Units</td><td>None</td></tr> <tr><td>Factory Default</td><td>5</td></tr> <tr><td>Minimum Value</td><td>1</td></tr> <tr><td>Maximum Value</td><td>8</td></tr> <tr><td>File – Group</td><td>Diagnostics – Trend Setup</td></tr> </table>	Parameter Number	487	Parameter Type	Read/Write, Non-Linkable Sink	Display Units / Drive Units	None	Factory Default	5	Minimum Value	1	Maximum Value	8	File – Group	Diagnostics – Trend Setup
Value	Description																																
1	Greater Than (.GT.)																																
2	Less Than (.LT.)																																
3	Equals (.EQ.)																																
4	Not Equals (.NE.)																																
5	Logical AND (.AND.)																																
6	Logical NAND (.NAND.)																																
7	Logical OR (.OR.)																																
8	Logical NOR (.NOR.)																																
Parameter Number	487																																
Parameter Type	Read/Write, Non-Linkable Sink																																
Display Units / Drive Units	None																																
Factory Default	5																																
Minimum Value	1																																
Maximum Value	8																																
File – Group	Diagnostics – Trend Setup																																
<p>488 Trend 4 Sample Rate [Tr4 Sample Rate]</p> <p>Tr4 Sample Rate specifies the interval at which the data in the Trend In 4 parameter is sampled. It is programmable in 2 millisecond increments. All values are rounded down to the nearest 2 millisecond interval.</p>	<table border="0"> <tr><td>Parameter Number</td><td>488</td></tr> <tr><td>Parameter Type</td><td>Read/Write, Non-Linkable Sink</td></tr> <tr><td>Display Units / Drive Units</td><td>Seconds</td></tr> <tr><td>Factory Default</td><td>0.020 Seconds</td></tr> <tr><td>Minimum Value</td><td>0.002 Seconds</td></tr> <tr><td>Maximum Value</td><td>30 Seconds</td></tr> <tr><td>File – Group</td><td>Diagnostics – Trend Setup</td></tr> </table>	Parameter Number	488	Parameter Type	Read/Write, Non-Linkable Sink	Display Units / Drive Units	Seconds	Factory Default	0.020 Seconds	Minimum Value	0.002 Seconds	Maximum Value	30 Seconds	File – Group	Diagnostics – Trend Setup																		
Parameter Number	488																																
Parameter Type	Read/Write, Non-Linkable Sink																																
Display Units / Drive Units	Seconds																																
Factory Default	0.020 Seconds																																
Minimum Value	0.002 Seconds																																
Maximum Value	30 Seconds																																
File – Group	Diagnostics – Trend Setup																																

<p>489 Trend 4 Post Samples [Tr4 Post Samples]</p> <p>Tr4 Post Samples specifies the number of data samples to be gathered once the trigger evaluation becomes true. There is always a sample reserved for the instance when the trigger condition becomes true.</p>	<p>Parameter Number 489 Parameter Type Read/Write, Non-Linkable Sink Display Units / Drive Units None Factory Default 15 Minimum Value 0 Maximum Value 499 File – Group Diagnostics – Trend Setup</p>
<p>490 Trend 4 Continuous Trigger [Tr4 Cont Trigger]</p> <p>Tr4 Cont Trigger specifies the type of trend. You can choose either 0 for one-shot or 1 for continuous.</p> <p>With a one-shot trend, once the trigger condition is true and the number of samples after the trigger is taken are gathered, the trend stops.</p> <p>With a continuous trend, once the trigger condition is true and the number of samples after the trigger is taken are gathered, the trend continues looking for the next occurrence of a true trigger condition.</p>	<p>Parameter Number 490 Parameter Type Read/Write, Non-Linkable Sink Display Units / Drive Units None Factory Default 0 Minimum Value 0 Maximum Value 1 File – Group Diagnostics – Trend Setup</p>
<p>491 Trend 4 Select [Tr4 Select]</p> <p>Tr4 Select specifies the trend mode. The states are as follows:</p> <ul style="list-style-type: none"> 0 Disable the trend. 1 Enable the trend. 2 Force a true trigger condition. 	<p>Parameter Number 491 Parameter Type Read/Write, Non-Linkable Sink Display Units / Drive Units None Factory Default 0 Minimum Value 0 Maximum Value 2 File – Group Diagnostics – Trend Setup Enums 0 = Disable 1 = Enable 2 = Force Trig</p>
<p>492 Trend 4 Status [Tr4 Status]</p> <p>Tr4 Status identifies which state the trend is currently in. The following states are possible:</p> <ul style="list-style-type: none"> 1 Stopped Trending is not executing. 2 Running Trending is executing, but the trigger point has not yet been reached. 3 Tripped/Trigger Trending is executing, and the trigger point has been reached. 4 Tripped/Forced The trigger point was forced. 	<p>Parameter Number 492 Parameter Type Read Only, Non-Linkable Source Display Units / Drive Units None Factory Default 1 Minimum Value 1 Maximum Value 4 File – Group Diagnostics – Trend I/O Enums 1 = Stopped 2 = Running 3 = Trip Trig 4 = Force Trip</p>

493 Trend Output 4

[Trend Out 4]

Trend Out 4 displays the latest 500 trend input data values once the trigger condition is true and all post samples are gathered. This parameter is updated at the same rate as the data was sampled. This parameter can be linked to Analog Output (for example) and a chart recorder connected to Analog Output to provide a hard copy of the trend data.

Parameter Number	493
Parameter Type	Read Only, Source
Display Units / Drive Units	None
Factory Default	0
Minimum Value	-32767
Maximum Value	+32767
File - Group	Diagnostics - Trend I/O

Troubleshooting

Chapter Objectives

Chapter 7 provides information to help you in troubleshooting the ControlNet Adapter Board. This chapter describes:

- the fault and status LEDs
- the fault queues
- the fault types
- the fault codes



ATTENTION: Only qualified personnel familiar with the 1336 FORCE drive system and associated machinery should perform troubleshooting or maintenance functions on the drive. Failure to comply may result in personal injury and/or equipment damage.



ATTENTION: When performing any troubleshooting on a 1336 FORCE drive equipped with a ControlNet adapter board make certain to check the Network Update Time (NUT). A NUT less than 5ms may cause data transfers to (and from) the drive to become non-deterministic.

Fault and Status LEDs

The following figure shows the fifteen status and fault LEDs that are located on the ControlNet Adapter Board to provide a visual indication of board operation. The ControlNet Adapter Board is a non-serviceable device. If you did not properly configure the ControlNet Adapter Board, the board will indicate faults and/or hardware malfunctions. You should verify the system configuration before checking for faults or hardware malfunctions.

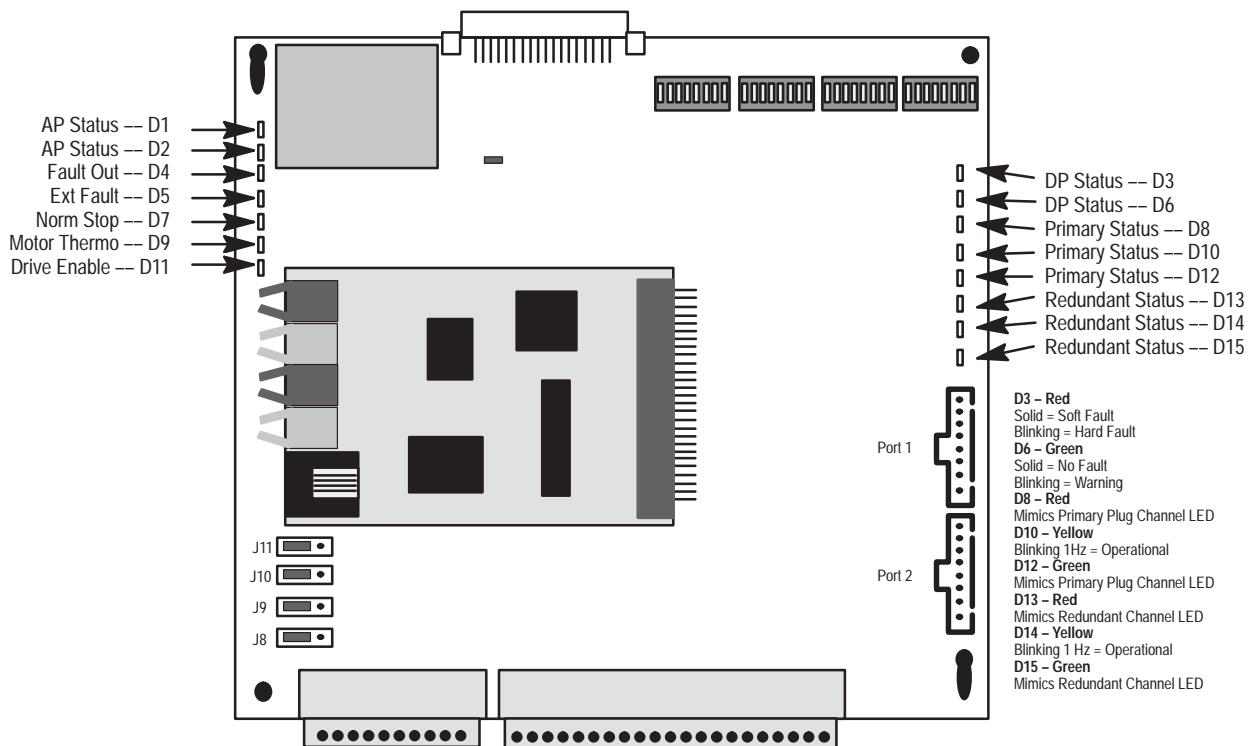

Application Processor (AP) Status D1 and D2

These LEDs reflect the operational status of the application processor.

LED:	State:	Function:
D1 (Red)	LED on	AP hard fault
	LED off	D6 on or hardware malfunction
	LED blinking	AP soft fault
D2 (Green)	LED on	Normal AP operation
	LED off	D3 on or hardware malfunction
	LED blinking	AP warning

Domino Processor (DP) Status D3 and D6

These LEDs reflect the operational status of the Domino processor.

LED:	State:	Function:
D3 (Red)	LED on	DP hard fault
	LED off	D6 on or hardware malfunction
	LED blinking	DP soft fault
D6 (Green)	LED on	Normal DP operation
	LED off	D3 on or hardware malfunction
	LED blinking	DP warning

ControlNet Adapter Status D4, D5, D7, D9, and D11

These LEDs reflect the operational status of the drive permissives.

LED:	State:	Function:
D4 (Red)	LED on	System fault present
	LED off	System fault not present
D5 (Red)	LED on	External fault present
	LED off	External fault not present
D7 (Red)	LED on	Normal drive stop signal present
	LED off	Normal drive stop signal not present
D9 (Red)	LED on	Motor thermoguard open
	LED off	Motor thermoguard closed
D11 (Green)	LED on	Drive enable signal present
	LED off	Drive disabled

Primary Channel Status D8, D10, and D12
Redundant Channel Status D13, D14, and D15

These LEDs reflect the operational status of ControlNet communications.

LED:	State:	ControlNet Adapter Function:
D8 and D13 (Red)	LED on	Hardware malfunction
	LED off	Communications loss or D12 and D15 on.
	LED blinking	A PLC has the rack inhibited or the PLC is in Reset/Program/Test mode
D10 and D14 (Yellow)	LED on	Malfunction
	LED off	Malfunction
	LED blinking	Operational
D12 and D15 (Green)	LED on	Normal PLC controller communications
	LED off	No communications to PLC control or D8 and D13 on
	LED blinking	PLC in Reset/Program/Test mode or PLC has rack inhibited

Fault Queues

All faults that have occurred are shown in the fault queue. Each entry shows the type of fault and the time and date that the fault occurred. The fault information stays in BRAM until you clear the queue by using the Clear Fault Queue command. You cannot clear the queue by issuing either a Clear Fault or a Drive Reset command or by recycling the drive power.

The fault queue may contain up to 32 faults. The following information is provided for each fault listed in the fault queue:

- a fault queue entry number to indicate the position of the fault in the fault queue
- a trip point (TP) to indicate which entry in the fault queue caused the drive to trip (all faults which are displayed in the queue before the TP fault occurred after the TP was logged)
- a five character decimal numbered fault code, which is described later in this chapter
- the time and date when the fault occurred
- descriptive fault text plus all clear fault commands and when they were executed

Faults

The 1336 FORCE monitors both internal and external operating conditions, responding to conditions that you program as being incorrect. Most malfunctions that occur will induce one of three types of faults.

Hard Faults

Hard faults indicate that the 1336 FORCE has detected a malfunction where internal recovery is not possible. Hard faults are the most severe type of faults. Hard faults indicate that a major internal component or system has malfunctioned and that drive functions may be lost. To recover from a hard fault, you must either issue a Drive Reset command or recycle the drive power.

Soft Faults

Soft faults exist to protect drive system components from internal and external malfunctions. Unlike hard faults, in most instances, you can maintain drive control when a soft fault occurs. Soft faults indicate that the 1336 FORCE has detected a malfunction that could damage drive control, power components, or the motor. Soft faults may also indicate undesirable external operating conditions. You can recover by issuing a Clear Fault command, a Clear Fault Queue command, a Drive Reset command, or by recycling the drive power.

Warning Faults

A warning fault has the lowest priority of all types of faults. A warning fault indicates a condition that if left uncorrected could result in a soft fault and is designed to annunciate a condition present in the system. When a warning fault occurs, the drive is not commanded to stop. Drive operation is not affected, but a fault code is entered into the fault queue reflecting the condition. You can recover by initiating a Clear Fault command, but this is not necessary for continued operation.

Configurable Faults

By using parameter programming, you can configure whether certain faults are reported as a soft fault, a warning fault, or no fault when the fault condition is present. You can use parameters 425 and 426 to configure the faults when you are using ControlNet communications. If you want the ControlNet Adapter Board to report the fault condition as a soft fault, you need to set the appropriate bit in parameter 425 for the primary channel. To have the ControlNet Adapter Board report the fault condition as a warning, you need to set the appropriate bit in parameter 426 and make sure that the corresponding bit is not set in parameter 425.

When a fault condition that is specific to ControlNet communications occurs, the ControlNet Adapter Board first checks parameter 425. If the bit representing the fault condition is set, the condition is reported as a soft fault. If the bit is not set, the ControlNet Adapter Board then checks parameter 426. If the corresponding bit is set in 426 but not set in parameter 425, the condition is reported as a warning. If the bit is not set in either parameter, the ControlNet Adapter Board does not report the condition and drive operation continues unaffected.



ATTENTION: Ignoring faults that have been configured as Report Only could damage certain components in the Drive.

Communication Fault Reporting and Handling

Connections and Transport Classes – ControlNet implements a producer–consumer model network. The drives support configurable point to point connections to and from other devices on the network. Every device has a physical connection to the network, but logical connections are also required between devices to support the exchange of data. Two transport classes are supported by the drives on ControlNet.

These are transport class 1 and transport class 3. Class 1 connections are used to pass 8 16-bit words of I/O data (1 full rack) each direction between a Controller and a Drive deterministically at a configurable periodic rate. This type of data transfer corresponds to data being shared via Remote I/O. Class 3 connections are also supported for messaging between devices. This data is what would be sent over Data Highway Plus or with RIO block transfer.

Types of Communication Loss – Loss of data communications can be due to either physical or logical reasons. Below are definitions and examples of the primary causes of communications loss.

Comm Loss – If the drive becomes physically disconnected from the network, this is the most obvious form of communication loss. But the drive can also lose its logical connections in a variety of ways. The network could be inoperable due to some required device being down or possibly if illegal data or noise is present on the network. The drive itself may be deemed illegal on the network for various reasons and will not be allowed to talk on the network. Any of these conditions may be reported as a general “ICN Comm Loss”. When this condition is reported, the drive is considered to be effectively disconnected from the network and unable to communicate in any way on the network.

Closed Connection – The drive is implemented as an adapter device on the network and does not initiate connections. One scanner device is allowed to make a Class 1 connection to a drive. Many devices of various kinds can open Class 3 connections to the drive at any time. When this happens, this may be reported as a “Class 1 Close” or a “Class 3 Close”.

Connection Timeout – All connections, once opened, must be maintained at some rate. If the drive does not receive data from any open connection within some period of time, a timeout condition is flagged. This event can be reported as “Class 1 Timeout” or as “Class 3 Timeout”.

Controller Not in Run Mode – In addition to a loss of data due to network errors or connections being lost, data may also be considered lost if the controller goes out of run mode for any reason. Data being received from a controller that is not in run mode is considered to be unreliable and is ignored by the drive. The condition of a controller transitioning out of run mode can be reported as “Reset/Prog/Test”.

Actions Resulting from Loss of Data – Any of the communication losses described above can be handled in various ways. The condition can cause a soft fault, which will cause a drive to stop active operation. The condition can be reported as a warning which means the event is annunciated, but does not change the running state of the drive. The condition may also be ignored. Beyond this, the handling for the loss of the Class 1 I/O data can also be configured with “Last State” bits that are defined in a subsequent section of this document. These bits are used to define the action to be taken with the Input image being used by the drive. This image can be either left in its last received state or it can be zeroed. Loss of I/O image would occur for the following conditions:

Reset/Prog/Test

ICN Comm Loss

Class 1 Close

Class 1 Timeout

Parameters Relating to Communication Loss – Each drive has two parameters that define how the communications losses get handled. These parameters are called “ICN Fault Select” and “ICN Warning Select”. In the 1336T, these are parameters 425 and 426. Operation of bits within these parameters is essentially identical to similar parameters used for RIO/DH+ adapters which exist at these parameter numbers. Bit positions are identical for all of these parameters in a ControlNet Adapter as detailed in the following table:

Bit Position	Description
0	Reset/Program/Test
1	Last State
2	ICN Comm Loss
3	Class 1 Close
4	Class 3 Close
5	Class 1 Timeout
6	Class 3 Timeout

If any bit is set to one in the Fault Select word, then if the corresponding event occurs, the drive will Soft Fault, and thus not be running. If the fault was one that causes loss of I/O image to be received (0,2,3,5) then the Last State bit is used to define what should be done to the entire Input Image (all 8 words). If Last State is a *one*, the input image is left in the last state prior to the fault being detected. If Last State is a zero, then the 8 input words are all set to zero.

The Warning Select parameter is used to determine if any event not specified to be handled as a fault in the Fault Select word should be treated as a warning. If a bit is set to a *one*, then a warning annunciation will occur for the corresponding event, but only if the corresponding bit in the Fault Select word is a zero. If any of the events that cause loss of I/O data occur (0,2,3,5) and that event is being annunciated as a warning, then the Last State bit in the Warning Select word is used to determine the state of the Input image. This works identically to the Last State bit for events being handled as faults.

If any bit position is set to zero for both the Fault Select word and the Warning Select word, then the event corresponding to that bit is ignored (not annunciated as either a fault or a warning). The Warning Select’s Last State bit is applied to the I/O image for the following events

ICN Comm Loss

Class 1 Close

Class 1 Timeout

The case of a Reset/Program/Test event occurring, but set set to be ignored will always result in the I/O image being left in the last state (not zeroed even if Warning Select’s Last State bit is zero). This is consistent with the operation of the existing RIO adapters.

Fault Code Descriptions

ControlNet Adapter Board fault and warning codes are five character decimal numbers that have the following format:

S	A	X	X	X
---	---	---	---	---

S

Source Designator

- 0 = Main Board Velocity Processor
- 1 = Main Board Current Processor
- 2 = Adapter Processor
- 3 = CNA Interface
- 4 = Reserved
- 5 = Reserved

A

Area Designator

- 0 = General
- 1 = Motor
- 2 = Inverter
- 3 = Motor Control
- 4 = Reserved Adapter
- 5 = External Device
- 6 = Communications
- 7 = Reserved
- 8 = Reserved
- 9 = Converter/Brake

XXX

Internal Fault Code

Fault Displays

Both HIM and GPT displays indicate a fault or warning by showing the adapter code and fault text. Fault text may be up to 16 characters in length.



The following are the fault codes.

Fault text and code:	Fault type:	Description:	Suggested action:
Faults Cleared 24000	None	This entry in the fault or warning queue is displayed when you request a clear fault command.	None
Adpt BRAM Cksm 24009	Soft	There is a discrepancy between the calculated checksum and the saved checksum for the adapter data.	Reset the drive. If the fault persists: <ol style="list-style-type: none"> 1. Execute a BRAM recall. 2. Execute a BRAM store. 3. Reset the drive. 4. Clear the faults. When you are done with these steps, verify all parameter values.

Fault text and code:	Fault type:	Description:	Suggested action:
Drv Types Differ 24010	Soft	There is a discrepancy between the drive type on the base driver board and the parameter 220 and 221 values in BRAM.	Reset the drive. If the fault persists: 1. Execute a BRAM recall. 2. Execute a BRAM store. 3. Reset the drive. 4. Clear the faults. When you are done with these steps, verify all parameter values.
I11 Drive Type 24011	Hard	The drive type code in Serial E2 on the base driver board is not a valid code per the language module table.	Replace the base driver board.
Main BRAM Cksm 24012	Soft	There is a discrepancy between the calculated checksum and the saved checksum for the main control board.	Reset the drive. If the fault persists: 1. Execute a BRAM recall. 2. Execute a BRAM store. 3. Reset the drive. 4. Clear the faults. When you are done with these steps, verify all parameter values.
SW Malfunction 24013	Hard	The integrity check on the board software has failed.	Reset the drive. If the fault persists, you may have to replace either the ControlNet Adapter Board or the main control board.
SW Malfunction 24014	Hard	The integrity check on the board software has failed.	Reset the drive. If the fault persists, you may have to replace either the ControlNet Adapter Board or the main control board.
SW Malfunction 24015	Hard	The integrity check on the board software has failed.	Reset the drive. If the fault persists, replace the ControlNet Adapter Board.
SW Malfunction 24016	Hard	The integrity check on the board software has failed.	Reset the drive. If the fault persists, replace the ControlNet Adapter Board.
SW Malfunction 24017	Hard	The integrity check on the board software has failed.	Reset the drive. If the fault persists, replace the ControlNet Adapter Board.
SW Malfunction 24018	Hard	The integrity check on the board software has failed.	Reset the drive. If the fault persists, replace the ControlNet Adapter Board.
AP SW/LM Rev Err 24025	Soft	There is a ControlNet Adapter Board software/language module mismatch.	Verify the board software and language module versions with Allen-Bradley.
Adapter Config Err 24026	Soft	The ControlNet Adapter Board has detected that the current firmware revision does not match the value stored in NVRAM	Verify that the adapter board and firmware revision is correct and execute a BRAM store to save the values.

Fault text and code:	Fault type:	Description:	Suggested action:
No AP LM Exists 25023	Hard	The ControlNet Adapter Board has detected that a language module has not been installed on the ControlNet Adapter Board.	Reset the drive. If the fault persists, replace the language module.
SP Pt1 Timeout 26038	Soft, warning, or none	The device connected to Port 1 of SCANport has been disconnected.	Reconnect Device if desired.
SP Pt2 Timeout 26039	Soft, warning, or none	The device connected to Port 2 of SCANport has been disconnected.	Reconnect Device if desired.
SP Pt3 Timeout 26040	Soft, warning, or none	The device connected to Port 3 of SCANport has been disconnected.	Reconnect Device if desired
SP Pt4 Timeout 26041	Soft, warning, or none	The device connected to Port 4 of SCANport has been disconnected.	Reconnect Device if desired.
SP Pt5 Timeout 26042	Soft, warning, or none	The device connected to Port 5 of SCANport has been disconnected.	Reconnect Device if desired.
SP Comm Fault 26043	Hard	The integrity check on the board hardware has failed.	Reset the drive. If the fault persists, replace the ControlNet Adapter Board.
HW Malfunction 34001	Hard	The integrity check on the board hardware has failed.	Reset the drive. If the fault persists, replace the ControlNet Adapter Board.
HW Malfunction 34002	Hard	The integrity check on the board hardware has failed.	Reset the drive. If the fault persists, replace the ControlNet Adapter Board.
HW Malfunction 34003	Hard	The integrity check on the board hardware has failed.	Reset the drive. If the fault persists, replace the ControlNet Adapter Board.
HW Malfunction 34004	Hard	The integrity check on the board hardware has failed.	Reset the drive. If the fault persists, replace the ControlNet Adapter Board.
HW Malfunction 34005	Hard	The integrity check on the board hardware has failed.	Reset the drive. If the fault persists, replace the ControlNet Adapter Board.
SW Malfunction 34016	Hard	The integrity check on the board software has failed.	Reset the drive. If the fault persists, replace the ControlNet Adapter Board.

Fault text and code:	Fault type:	Description:	Suggested action:
CNET Comm Loss 36019	Soft, warning, or none	The ControlNet Adapter Board has detected a loss of primary channel communications with the controller.	Check for a break in the communications cable. Verify that all connections are intact. Clear the fault by issuing a Clear Fault or a Drive Reset command, or by recycling power. Check parameters 425 (ICN Flt Sel) and 426 (ICN Warn Sel) to determine the drive response to faults. These parameters determine the resolution of the condition, either fault, warning, or none. Both parameters are bit coded.
PLC Res/Pgm/Test 35000	Soft/ Warning/ None	The ControlNet Adapter Board has detected the controller being switched from the run mode to another mode.	Check the PLC mode switch and the I/O control reset. Clear the fault by issuing a Clear Fault or a Drive Reset command, or by recycling the power. Check parameters 425 (ICN Flt Sel) and 426 (ICN Warn Sel) to determine the drive response to faults. These parameters determine the resolution of the condition, either fault, warning, or none. Both parameters are bit coded.
Class 1 Close 36020	Soft/ Warning/ None	Scanner Device (PLC) closed the connection to the drive. This could be due to timeout condition or due to action initiated by the scanner due to programming or possible error recovery.	Check connections & cable. Check the state of the Scanner Device (PLC). Check programming within the PLC.
Class 3 Close 36021	Soft/ Warning/ None	Device closed a messaging connection to the drive. This could be due to a timeout condition or due to action initiated by the device due to programming or possible error recovery.	Check connections & cable. Check state of the Scanner Device (PLC). Check programming within the PLC.
Class 1 Timeout 36022	Soft/ Warning/ None	Drive Timed out on scheduled control data reception from the Scanner Device (PLC).	Check connections & cables. Check that PLC is operational. Check for general errors occurring on the network. Check that the network was not being re-configured.

Fault text and code:	Fault type:	Description:	Suggested action:
Class 3 Timeout 36023	Soft/ Warning? None	Drive timed out on scheduled control data reception from a device.	Check connections & cables. Check that all devices that are configured on the network have a class 3 connection to the drive operational. Check programming within the PLC or any other device with a class 3 connection to the drive. Check for general errors occurring on the network. Check that the network was not being reconfigured.
Plug Failure 36024	Hard	Internal Fault detected	Check version of Adapter Board for compatibility with Main board. If condition persists, replace adapter board.

This Page Intentionally Blank

Using the Trend Features

Setting Up Trending

Trending is a diagnostic tool that you can use to capture and retain an input parameter data value until a trigger condition occurs. The FORCE has the capacity to setup and monitor up to 4 parameters, Trend 1 through Trend 4. With trending, you program the:

- Parameter to sample
- Trigger condition
- Sampling rate
- Quantity of samples to be taken after the trigger occurs
- Whether trending is to occur one time or continuously

Parameters used by trending are shown in the table below:

Description	Trend 1 Parameter Number:	Trend 2 Parameter Number	Trend 3 Parameter Number	Trend 4 Parameter Number
Source	454	464	474	484
Variable X Source	455	465	475	485
Variable Y Source	456	466	476	486
Operator (comparison type)	457	467	477	487
Sampling Rate	458	468	478	488
Quantity of Post-Trigger Samples	459	469	479	489
Mode	460	470	480	490
Select	461	471	481	491
Status	462	472	482	492
Output	463	473	483	493

Selecting the Parameter to Sample

Identify the number of the parameter you want to sample as follows:

If you are programming Trend #:	Then enter the number of the parameter to be sampled in:
1	454
2	464
3	474
4	484

Setting the Trigger Condition

The trigger condition defines the event that must be true before the trend is triggered (activated). After the trend is activated and the required number of post samples have been recorded, the last 500 samples for that trend are made accessible via the output parameter.

The following statement determines the trigger point:

[Variable X] [Operator] [Variable Y]

Variable X is compared to Variable Y. If the condition specified by the Operator is true, then the trend is triggered. Typically, you link one variable to a parameter and the other variable to either a parameter or a constant value.



Important: You should make sure that you are comparing either both signed parameters, or both unsigned parameters. Trying to compare a signed parameter to an unsigned parameter could cause unexpected results.

To set the trigger condition:

1. Identify the parameter number of the parameter whose value you want to be variable X.

2.

If you have identified a parameter number for variable X and are programming Trend:	Then enter the number of the parameter to be sampled in:
1	Parameter 455
2	Parameter 465
3	Parameter 475
4	Parameter 485

3. Identify the parameter of the parameter you want to be Variable Y.

4.

If you have identified a parameter number for variable Y and are programming Trend:	Then enter the number of the parameter to be sampled in:
1	Parameter 456
2	Parameter 466
3	Parameter 476
4	Parameter 486

5. Select the number that corresponds to the desired operator using the table below:

Number	This Operator	Compare:
0	GT (Greater Than)	Data Values for X and Y
1	LT (Less Than)	Data Values for X and Y
2	EQ (Equal)	Data Values for X and Y
3	NE (Not Equal)	Data Values for X and Y
4	AND	16-bit word in X to a 16 bit mask in Y
5	NAND (Negated AND)	16-bit word in X to a 16 bit mask in Y
6	OR	16-bit word in X to a 16 bit mask in Y
7	NOR (Negated OR)	16-bit word in X to a 16 bit mask in Y



Important: Remember that the trigger condition is compared in the following manner [Variable X] [Operator] [Variable Y].

- 6.



If you are programming Trend:	Then enter the operator in:
1	Parameter 457
2	Parameter 467
3	Parameter 476
4	Parameter 486

Setting the Sampling Rate

You can specify how often you want the FORCE Drive to take data samples. Data samples may be taken from 2 milliseconds apart to 30 seconds apart.



Note: *The trigger condition is evaluated:*

-  at the rate of sampling whenever the sampling rate is less than 20 milliseconds.
-  at 20 milliseconds whenever the sampling rate exceeds 20 milliseconds.

1. Select a sampling rate between 0 and 30 seconds.

2.

If you are programming Trend:	Then enter the sample rate in:
1	Parameter 458
2	Parameter 468
3	Parameter 478
4	Parameter 488



Note: *The FORCE drive will round the desired sample rate to the nearest 2-millisecond interval.*

Setting the Number of Post Samples

You also need to specify the number of data samples to be taken once a trigger condition occurs. You can specify that 0 to 499 post samples be taken. One sample is reserved for the instance when the trigger condition becomes true.



Note: *“Pre-samples” are samples taken prior to the trigger condition becoming true.*



Important: Typically, when a trend buffer is set to trigger on a fault, you would set the post sample quantity to a lower value, such as 20. This allows you to evaluate the trended parameter’s data from before the trigger.

When a trend buffer is set up as a level detector, the post sample value is generally set to a higher value. This allows you to evaluate what happened after the trigger occurred.

1. Determine the number of samples to be taken after the trigger point becomes true.

2.

If you are programming Trend:	Then enter the post trigger samples in:
1	Parameter 459
2	Parameter 469
3	Parameter 479
4	Parameter 489



Important: If the trigger condition occurs before the pre-samples can be taken, the pre-samples may be unreliable. The pre-samples are valid only if the trigger does not occur before the pre-sample time has elapsed. You can use the following equation to determine pre-sample time:

$$T_1 = (500 - S_2 - 1) \times R_S$$

T_1 pre-sample time

S_2 the number of post samples

R_S the sample rate

Setting the Trend Mode and Selection

1.

If you want the trend to be:	Then enter the post trigger samples in:
Continuous	1
Oneshot	0

2.

If you are programming Trend:	Then enter the post trigger samples in:
1	Parameter 460
2	Parameter 470
3	Parameter 480
4	Parameter 490

3.

If you want the trend to be:	Then enter the post trigger samples in:
Disabled	0
Enabled	1
Forced to Trigger	2

4.

If you are programming Trend:	Then enter the mode value in:
1	Parameter 461
2	Parameter 471
3	Parameter 481
4	Parameter 491

Trending Status

The trending operation has five associated states (refer to Figure 12.1 for an illustration of the trending operation cycle.):

Number	This Operator:	Compares:
0	Unprogrammed	Trending is not operational
1	Stopped	No data samples are being taken and output contains the data samples that have been taken for the previous trending
2	Running	The trigger condition has not been reached and data samples are being taken at the specified rate. Output contains the data samples from the previous trend.
3	Triggered	The trigger condition has occurred and the post samples are being taken.
4	Forced Triggered	The trigger condition was forced so that the post samples could be taken.

Figure 8.1
Trending Operation Cycle

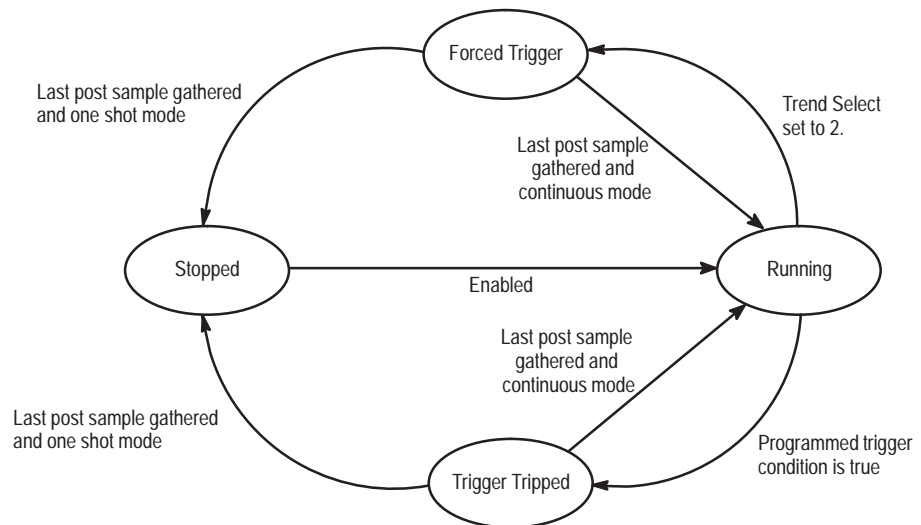

1.

For the status of Trend:	See:
1	Parameter 462
2	Parameter 472
3	Parameter 482
4	Parameter 492

Looking at the Output

When the trend output is linked to the analog output and a chart recorder is then connected to the analog output, you can view the trend output. To locate the starting point of a trend, look for a negative spike followed by a positive spike. These spikes are added to indicate the oldest piece of sampled data.

If you want to look at the current data, you can read the real time trend sample data using:

- the DriveTrending portion of the DriveTools software
- a GPT
- Drive Explorer

Specifications and Supplemental Information

Chapter Objectives

Chapter 9 provides specifications and a software block diagram.

Specifications

The following table shows the specifications for the ControlNet Adapter Board:

This category:	Has these specifications:
Environmental	Operating temperature: 0 to 40°C (32 to 104°F)
	Storage temperature: -40 to 70°C (-40 to 158°F)
	Relative humidity: 5 to 95% non-condensing
	Shock: 15G peak for 11 ms duration (±1.0 ms)
	Vibration: 0.15 mm (0.006 inches) displacement, 1G peak
Electrical	Input voltage: supplied by drive
	Input frequency: NA
	Input current: NA
	SCANport load: 60 mA
	Vibration: 0.15 mm (0.006 inches) displacement, 1G peak
Communications	Drive side: SCANport peripheral interface
	PLC side: Allen-Bradley ControlNet
	Baud rate: 5 Mbits
	Rack size: 8 words In/8 words Out
Analog I/O	Differential impedance for input: greater than 1 Ohm
	Single-ended impedance for input: 20K Ohm
	Maximum voltage for input: ±10V
	Output impedance: 100 Ohm
	Output voltage: ±10V
	Maximum current for output 1mA

Software Block Diagram

The following figures show the parameter linking and interactions within the ControlNet Adapter Board. For more information about parameter linking, refer to Chapter 5, *Understanding the Resources of Your Drive*.

SCANport

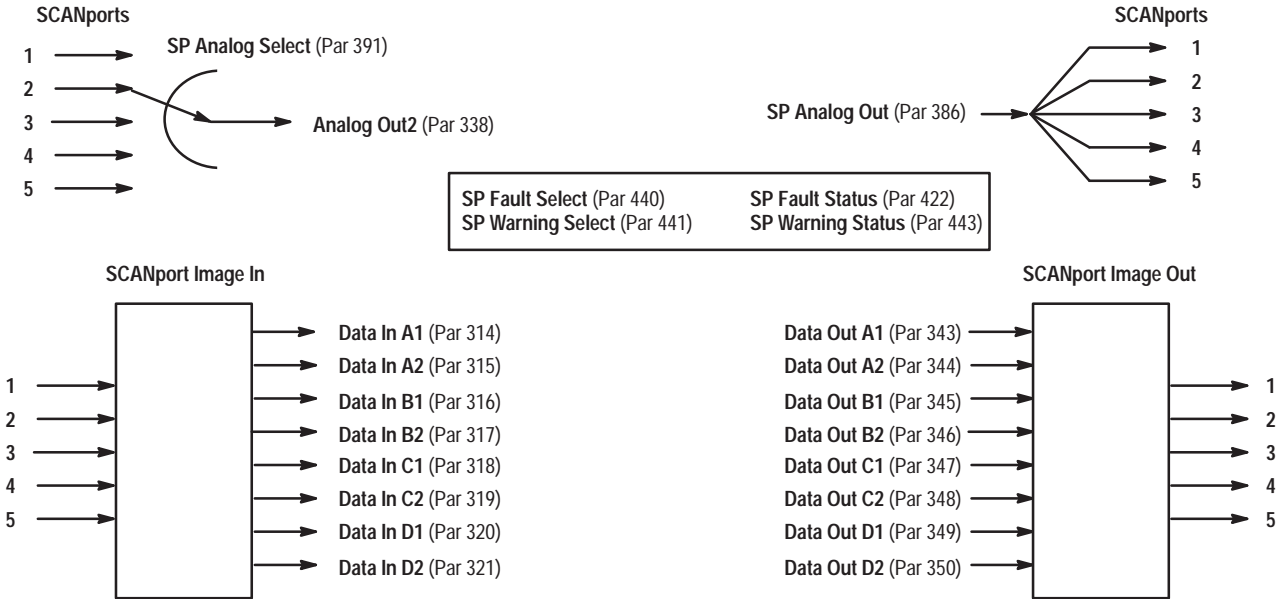

Logic Command

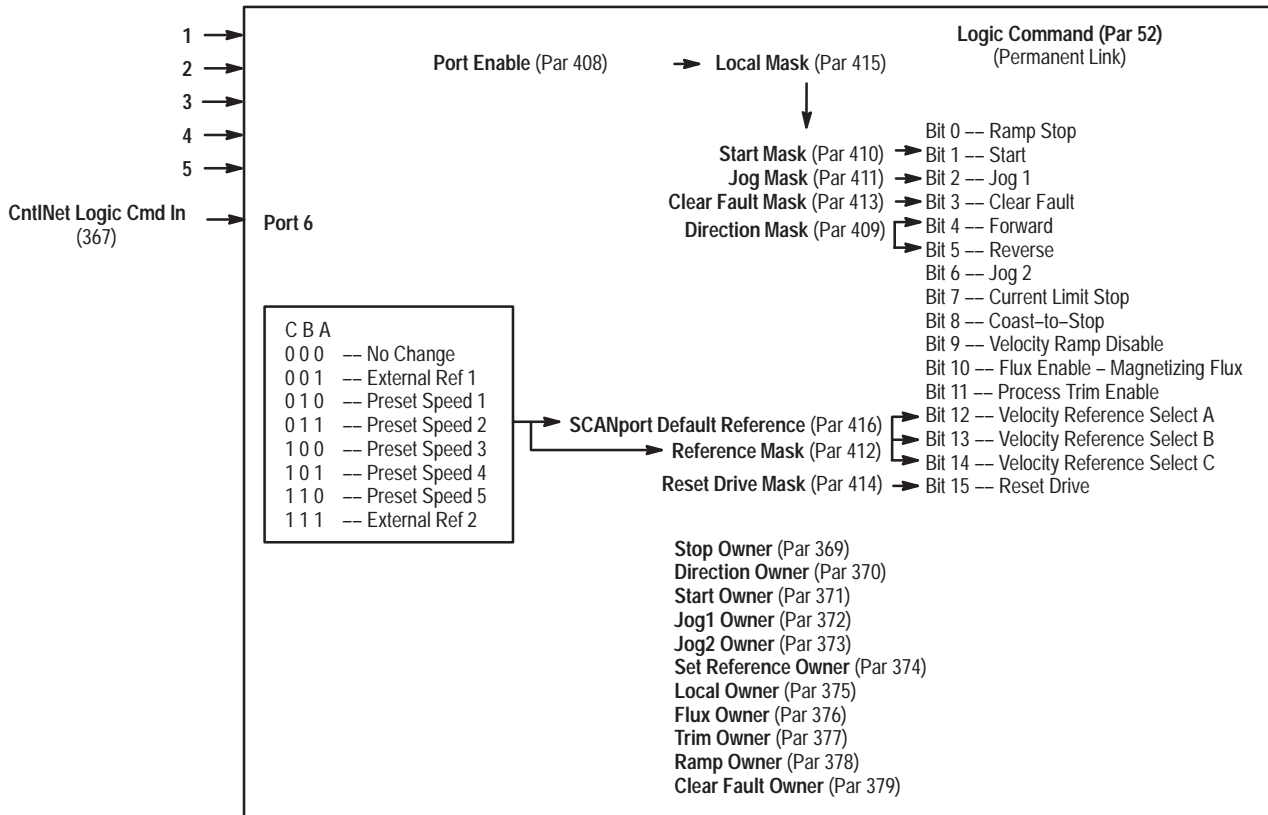

CntlNet Parameters

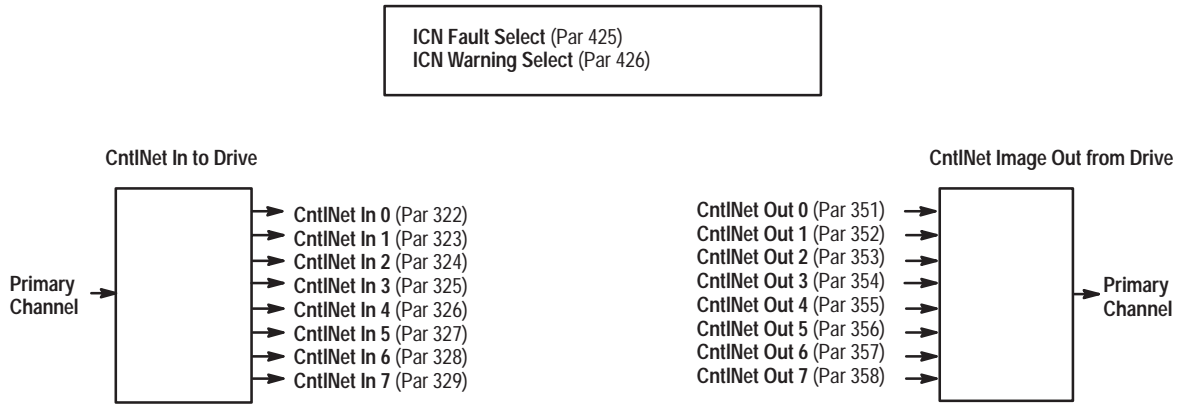

Analog I/O Parameters

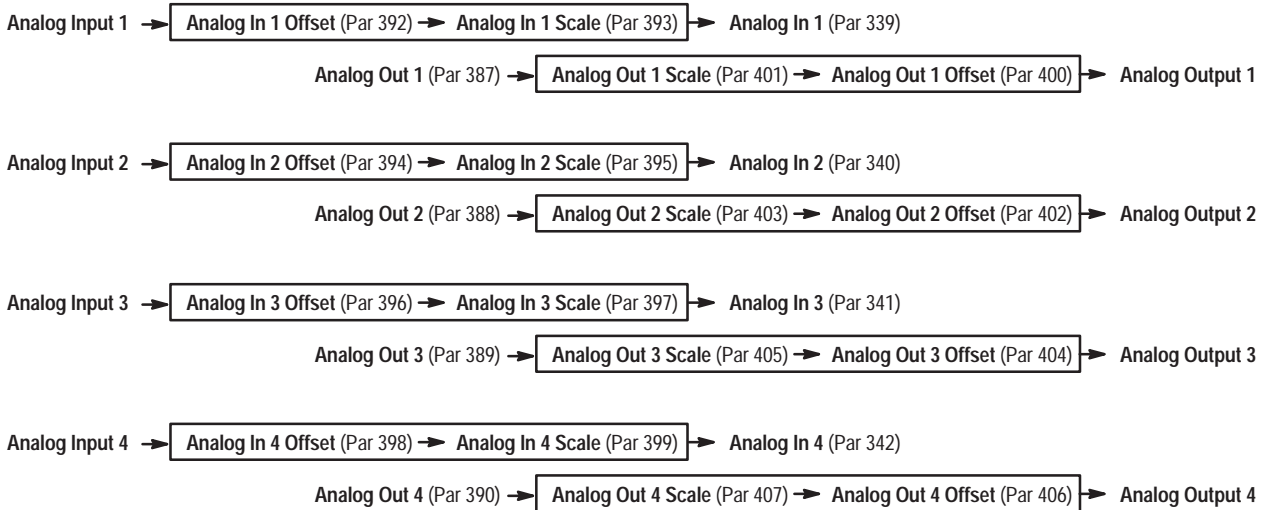

Hardware Block Diagram

The following is the hardware block diagram for the ControlNet Adapter Board.

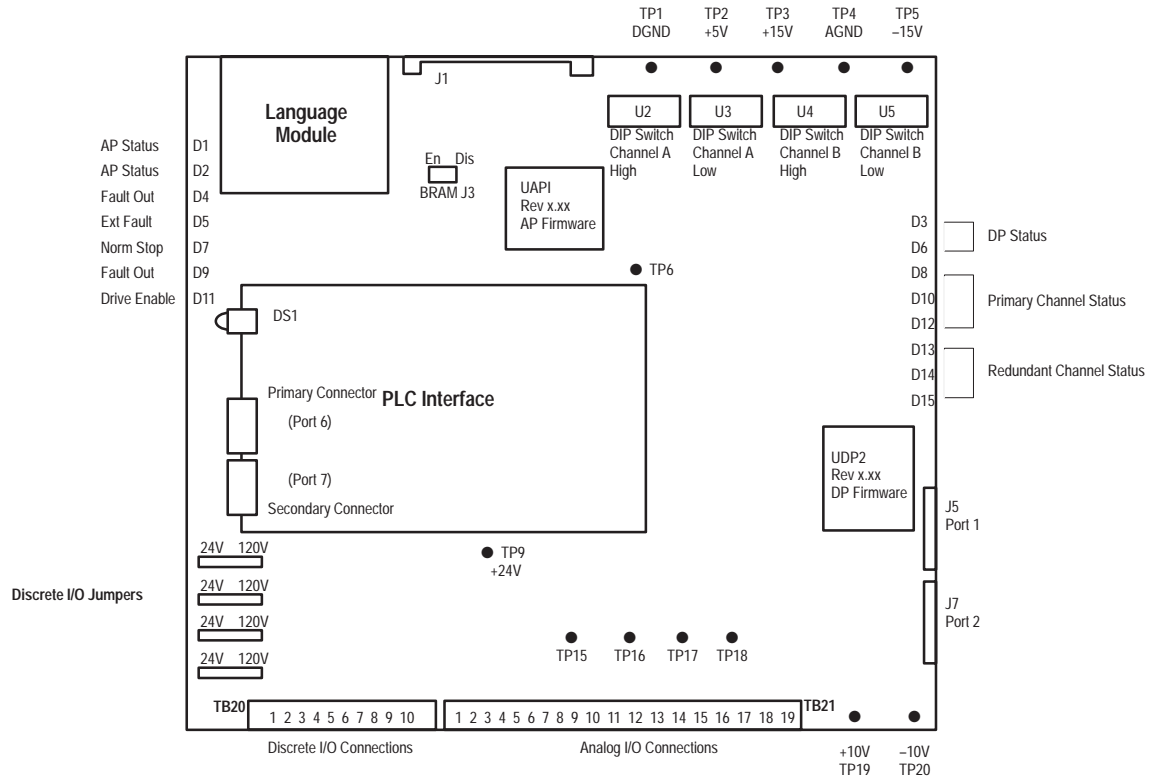

Parameter Cross Reference--By Number

The following table lists the parameters in numerical order.

No.	Name	Group ^①	Page	No.	Name	Group ^①	Page
300	Adapter ID	1 -- Adapter Info	6-12	344	Data Out A2	3 -- SCANport I/O	6-19
301	Adapter Version	1 -- Adapter Info	6-12	345	Data Out B1	3 -- SCANport I/O	6-19
302	SP Comm Retries	1 -- Adapter Info	6-12	346	Data Out B2	3 -- SCANport I/O	6-19
303	ChA DIP Switch	7 -- Channel A	6-12	347	Data Out C1	3 -- SCANport I/O	6-19
304				348	Data Out C2	3 -- SCANport I/O	6-19
305	ChA LED State	7 -- Channel A	6-12	349	Data Out D1	3 -- SCANport I/O	6-20
306				350	Data Out D2	3 -- SCANport I/O	6-20
307	ICN Board Status	1 -- Adapter Info	6-13	351	CntlNet Out 0	7 -- Channel A	6-20
309	Language Sel	1 -- Adapter Info	6-13	352	CntlNet Out 1	7 -- Channel A	6-20
314	Data In A1	3 -- SCANport I/O	6-13	353	CntlNet Out 2	7 -- Channel A	6-21
315	Data In A2	3 -- SCANport I/O	6-13	354	CntlNet Out 3	7 -- Channel A	6-21
316	Data In B1	3 -- SCANport I/O	6-13	355	CntlNet Out 4	7 -- Channel A	6-21
317	Data In B2	3 -- SCANport I/O	6-13	356	CntlNet Out 5	7 -- Channel A	6-22
318	Data In C1	3 -- SCANport I/O	6-14	357	CntlNet Out 6	7 -- Channel A	6-22
319	Data In C2	3 -- SCANport I/O	6-14	358	CntlNet Out 7	7 -- Channel A	6-22
320	Data In D1	3 -- SCANport I/O	6-14	359			
321	Data In D2	3 -- SCANport I/O	6-14	360			
322	CntlNet In 0	7 -- Channel A	6-15	361			
323	CntlNet In 1	7 -- Channel A	6-15	362			
324	CntlNet In 2	7 -- Channel A	6-15	363			
325	CntlNet In 3	7 -- Channel A	6-16	364			
326	CntlNet In 4	7 -- Channel A	6-16	365			
327	CntlNet In 5	7 -- Channel A	6-16	366			
328	CntlNet In 6	7 -- Channel A	6-17	367	CntlNet Cmd In	3 -- Logic	6-23
329	CntlNet In 7	7 -- Channel A	6-17	368			
330				369	Stop Owner	5 -- Owners	6-23
331				370	Dir Owner	5 -- Owners	6-23
332				371	Start Owner	5 -- Owners	6-24
333				372	Jog 1 Owner	5 -- Owners	6-24
334				373	Jog 2 Owner	5 -- Owners	6-24
335				374	Set Ref Owner	5 -- Owners	6-24
336				375	Local Owner	5 -- Owners	6-24
337				376	Flux Owner	5 -- Owners	6-25
338	SP Analog In	3 -- Analog Input	6-17	377	Trim Owner	5 -- Owners	6-25
339	Analog In 1	6 -- Analog Input	6-18	378	Ramp Owner	5 -- Owners	6-25
340	Analog In 2	6 -- Analog Input	6-18	379	Clr Fault Owner	5 -- Owners	6-25
341	Analog In 3	6 -- Analog Input	6-18	386	SP Analog Out	3 -- Analog Output	6-25
342	Analog In 4	6 -- Analog Input	6-18	387	Analog Out 1	6 -- Analog Output	6-26
343	Data Out A1	3 -- SCANport I/O	6-19	388	Analog Out 2	6 -- Analog Output	6-26

① Parameters included in Groups 7 and 8 depend on the selected communications.



Shaded parameters do not exist when DH+ is selected. Inputs are variable and depend on rack size and whether block transfer is enabled.

No.	Name	Group ^①	Page	No.	Name	Group ^①	Page
389	Analog Out 3	6 -- Analog I/O	6-26	443	SP Warn Sts	2 -- Adapter Diagnostics	6-36
390	Analog Out 4	6 -- Analog I/O	6-26	454	Trend In 1	9 -- Trend I/O	6-36
391	SP Analog Sel	3 -- Analog Input	6-26	455	Tr1 Opnd Parm X	9 -- Trend Setup	6-36
392	An In 1 Offset	6 -- Analog Input	6-27	456	Tr1 Opnd Parm Y	9 -- Trend Setup	6-37
393	An In 1 Scale	6 -- Analog Input	6-27	457	Tr1 Operator	9 -- Trend Setup	6-37
394	An In 2 Offset	6 -- Analog Input	6-27	458	Tr1 Sample Rate	9 -- Trend Setup	6-37
395	An In 2 Scale	6 -- Analog Input	6-27	459	Tr1 Post Samples	9 -- Trend Setup	6-37
396	An In 3 Offset	6 -- Analog Input	6-28	460	Tr1 Cont Trigger	9 -- Trend Setup	6-38
397	An In 3 Scale	6 -- Analog Input	6-28	461	Tr1 Select	9 -- Trend Setup	6-38
398	An In 4 Offset	6 -- Analog Input	6-28	462	Tr1 Status	9 -- Trend I/O	6-38
399	An In 4 Scale	6 -- Analog Input	6-28	463	Trend Out 1	9 -- Trend I/O	6-38
400	An Out 1 Offset	6 -- Analog Output	6-29	464	Trend In 2	9 -- Trend I/O	6-39
401	An Out 1 Scale	6 -- Analog Output	6-29	465	Tr2 Opnd Parm X	9 -- Trend Setup	6-39
402	An Out 2 Offset	6 -- Analog Output	6-29	466	Tr2 Opnd Parm Y	9 -- Trend Setup	6-39
403	An Out 2 Scale	6 -- Analog Output	6-29	467	Tr2 Operator	9 -- Trend Setup	6-39
404	An Out 3 Offset	6 -- Analog Output	6-30	468	Tr2 Sample Rate	9 -- Trend Setup	6-40
405	An Out 3 Scale	6 -- Analog Output	6-30	469	Tr2 Post Samples	9 -- Trend Setup	6-40
406	An Out 4 Offset	6 -- Analog Output	6-30	470	Tr2 Cont Trigger	9 -- Trend Setup	6-40
407	An Out 4 Scale	6 -- Analog Output	6-30	471	Tr2 Select	9 -- Trend Setup	6-40
408	Port Enable	4 -- Masks	6-31	472	Tr2 Status	9 -- Trend I/O	6-40
409	Dir Mask	4 -- Masks	6-31	473	Trend Out 2	9 -- Trend I/O	6-41
410	Start Mask	4 -- Masks	6-31	474	Trend In 3	9 -- Trend I/O	6-41
411	Jog Mask	4 -- Masks	6-31	475	Tr3 Opnd Parm X	9 -- Trend Setup	6-41
412	Ref Mask	4 -- Masks	6-31	476	Tr3 Opnd Parm Y	9 -- Trend Setup	6-41
413	Clr Fault Mask	4 -- Masks	6-32	477	Tr3 Operator	9 -- Trend Setup	6-42
414	Reset Drive Mask	4 -- Masks	6-32	478	Tr3 Sample Rate	9 -- Trend Setup	6-42
415	Local Mask	4 -- Masks	6-32	479	Tr3 Post Samples	9 -- Trend Setup	6-42
416	SP Default Ref	3 -- Velocity Ref	6-32	480	Tr3 Cont Trigger	9 -- Trend Setup	6-42
425	ICN Flt Sel	2 -- Adapter Diagnostics	6-33	481	Tr3 Select	9 -- Trend Setup	6-43
426	ICN Warn Sel	2 -- Adapter Diagnostics	6-34	482	Tr3 Status	9 -- Trend I/O	6-43
427				483	Trend Out 3	9 -- Trend I/O	6-43
430				484	Trend In 4	9 -- Trend I/O	6-43
431				485	Tr4 Opnd Parm X	9 -- Trend Setup	6-44
432				486	Tr4 Opnd Parm Y	9 -- Trend Setup	6-44
435	DIP Fault Setup	2 -- Adapter Diagnostics	6-35	487	Tr4 Operator	9 -- Trend Setup	6-44
436				488	Tr4 Sample Rate	9 -- Trend Setup	6-44
437				489	Tr4 Post Samples	9 -- Trend Setup	6-45
438				490	Tr4 Cont Trigger	9 -- Trend Setup	6-45
439				491	Tr4 Select	9 -- Trend Setup	6-45
440	SP Fault Sel	2 -- Adapter Diagnostics	6-35	492	Tr4 Status	9 -- Trend I/O	6-45
441	SP Warn Sel	2 -- Adapter Diagnostics	6-35	493	Trend Out 4	9 -- Trend I/O	6-46
442	SP Fault Sts	2 -- Adapter Diagnostics	6-36				

① Parameters included in Groups 7 and 8 depend on the selected communications.

www.rockwellautomation.com

Power, Control and Information Solutions Headquarters

Americas: Rockwell Automation, 1201 South Second Street, Milwaukee, WI 53204-2496 USA, Tel: (1) 414.382.2000, Fax: (1) 414.382.4444

Europe/Middle East/Africa: Rockwell Automation, Vorstlaan/Boulevard du Souverain 36, 1170 Brussels, Belgium, Tel: (32) 2 663 0600, Fax: (32) 2 663 0640

Asia Pacific: Rockwell Automation, Level 14, Core F, Cyberport 3, 100 Cyberport Road, Hong Kong, Tel: (852) 2887 4788, Fax: (852) 2508 1846

Publication 1336 FORCE-5.18 – March, 1999
Supersedes September, 1998

P/N 185623 (02)
Copyright 1999 Rockwell International Corporation. All rights reserved. Printed in USA.