

ACS850

efesotomasyon.com

Hardware Manual ACS850-04 Drive Modules (0.37 to 45 kW)



ACS850 drive manuals

DRIVE HARDWARE MANUALS*

ACS850-04 Drive Modules (0.37 to 45 kW) Hardware Manual – 3AUA0000045496 (English)

DRIVE FIRMWARE MANUALS

ACS850 Standard Control Program Firmware Manual** – 3AUA0000045497 (English)

OPTION MANUALS

ACS-CP-U Control Panel IP54 Mounting Platform Kit (+J410) Installation Guide – 3AUA0000049072 (English)

Manuals for I/O Extension Modules, Fieldbus Adapters etc.

APPLICATION GUIDES

Application programming for ACS850 drives – 3AUA0000078664 (English)

ATEX certified safe disconnection function for ACS850 drives – 3AUA0000074343 (English)

Safe torque off function for ACSM1, ACS850 and ACQ810 drives – 3AFE68929814 (English)

*The delivery includes a multilingual quick installation guide.

**The delivery includes a multilingual quick start-up guide.

ACS850-04 Drive Modules
0.37 to 45 kW

Hardware Manual

3AUA0000045496 Rev E EN
EFFECTIVE: 2010-10-26

Safety instructions

What this chapter contains

This chapter contains safety instructions which you must follow when installing, operating and servicing the drive. If ignored, physical injury or death may follow, or damage may occur to the drive, the motor, or driven equipment. Read the safety instructions before you work on the unit.

Use of warnings and notes

There are four types of safety instructions used in this manual:



Electricity warning warns of high voltage which can cause physical injury and/or damage to the equipment.



General warning warns about conditions, other than those caused by electricity, which can result in physical injury and/or damage to the equipment.



Electrostatic discharge warning warns of electrostatic discharge which can damage the equipment.



Hot surface warning warns of component surfaces that may become hot enough to cause burns if touched.

Installation and maintenance work

These warnings are intended for all who work on the drive, motor cable or motor.



WARNING! Ignoring the following instructions can cause physical injury or death, or damage to the equipment.

Only qualified electricians are allowed to install and maintain the drive.

- Never work on the drive, the motor cable or the motor when input power is applied. After disconnecting the input power, always wait for 5 minutes to let the intermediate circuit capacitors discharge before you start working on the drive, the motor or the motor cable.

Always ensure by measuring with a multimeter (impedance at least 1 Mohm) that:

1. There is no voltage between the drive input phases U1, V1 and W1 and the ground.
 2. There is no voltage between terminals UDC+ and UDC– and the ground.
 3. There is no voltage between terminals R+ and R– and the ground.
- Drives controlling a permanent magnet motor: A rotating permanent magnet motor feeds power to the drive causing the drive to become live even when it is stopped and the supply power switched off. Before maintenance work on the drive,
 - disconnect the motor from the drive by using a safety switch
 - prevent the start-up of any other motors in the same mechanical system
 - lock the motor shaft
 - measure that the motor is in fact de-energised, then connect the U2, V2 and W2 terminals of the drive to each other and to the PE.
 - Do not work on the control cables when power is applied to the drive or to the external control circuits. Externally supplied control circuits may carry dangerous voltages even when the input power of the drive is switched off.
 - Do not make any insulation or voltage withstand tests on the drive.
 - If a drive whose varistors or internal EMC filters are not disconnected is installed on an IT power system (an ungrounded power system or a high resistance grounded [over 30 ohms] power system), the drive will be connected to earth potential through the varistors/filters. This may cause danger or damage the drive.
 - If a drive whose varistors or internal EMC filter are not disconnected is installed on a corner-grounded TN system, the drive will be damaged.

Notes:

- Even when the motor is stopped, dangerous voltages are present at the power circuit terminals U1, V1, W1 and U2, V2, W2, and UDC+, UDC–, R+, R–.

- Depending on the external wiring, dangerous voltages (115 V, 220 V or 230 V) may be present on the terminals of the relay outputs of the drive.
- The drive supports the Safe torque off function. See page [42](#).



WARNING! Ignoring the following instructions can cause physical injury or death, or damage to the equipment.

- The drive is not field repairable. Never attempt to repair a malfunctioning drive; contact your local ABB representative or Authorized Service Center for replacement.
- Make sure that dust from drilling does not enter the drive during the installation. Electrically conductive dust inside the drive may cause damage or lead to malfunction.
- Ensure sufficient cooling.



WARNING! The printed circuit boards contain components sensitive to electrostatic discharge. Wear a grounding wrist band when handling the boards. Do not touch the boards unnecessarily.

Start-up and operation

These warnings are intended for all who plan the operation of the drive, start up or operate the drive.



WARNING! Ignoring the following instructions can cause physical injury or death, or damage to the equipment.

- Before adjusting the drive and putting it into service, make sure that the motor and all driven equipment are suitable for operation throughout the speed range provided by the drive. The drive can be adjusted to operate the motor at speeds above and below the speed provided by connecting the motor directly to the power line.
- Do not activate automatic fault reset functions if dangerous situations can occur. When activated, these functions will reset the drive and resume operation after a fault.
- Do not control the motor with an AC contactor or disconnecting device (disconnecting means); instead, use the control panel or external commands via the I/O board of the drive or a fieldbus adapter. The maximum allowed number of charging cycles of the DC capacitors (i.e. power-ups by applying power) is one per two minutes. The maximum total number of chargings is 100000 for frame sizes A and B, 50000 for frame sizes C and D.
- Drives controlling a permanent magnet motor: Do not run the motor over the rated speed. Motor overspeed leads to overvoltage which may permanently damage the drive.

Notes:

- If an external source for start command is selected and it is ON, the drive will start immediately after an input voltage break or a fault reset unless the drive is configured for 3-wire (pulse) start/stop.
- When the control location is not set to local, the stop key on the control panel will not stop the drive.



WARNING! The surfaces of drive system components (such as the mains choke and braking resistor, if present) become hot when the system is in use.

Table of contents

ACS850 drive manuals 2

Safety instructions

What this chapter contains 5
 Use of warnings and notes 5
 Installation and maintenance work 6
 Start-up and operation 8

Table of contents

About this manual

What this chapter contains 15
 Compatibility 15
 Intended audience 15
 Categorization according to the frame size 15
 Categorization according to the + code 15
 Contents 15
 Installation and commissioning flowchart 17
 Terms and abbreviations 19

Operation principle and hardware description

What this chapter contains 21
 Operation principle 21
 Main circuit 21
 Motor control 22
 Product overview 22
 Layout 23
 Power connections and control interfaces 24
 Type designation 25
 Ordering information 26

Planning the cabinet assembly

What this chapter contains 27
 Cabinet construction 27
 Disposition of the devices 27
 Grounding of mounting structures 27
 Main dimensions and free space requirements 28
 Cooling and degrees of protection 29
 Preventing the recirculation of hot air 31
 Outside the cabinet 31
 Inside the cabinet 31

Cabinet heaters	31
-----------------------	----

Mechanical installation

Contents of the package	33
Delivery check and drive module identification	35
Before installation	35
Requirements for the installation site	35
Installation procedure	36
Direct wall mounting	36
DIN rail mounting (Frames A and B only)	36
Mains choke installation	37
EMC filter installation	37
Braking resistor installation	37

Planning the electrical installation

What this chapter contains	39
Motor selection	39
Supply connection	39
Supply disconnecting device	39
Europe	39
Other regions	40
Thermal overload and short circuit protection	40
Thermal overload protection	40
Protection against short-circuit in motor cable	40
Protection against short-circuit in the supply cable or the drive	40
Operating time of the fuses and circuit breakers	40
Circuit breakers	40
Motor thermal protection	41
Ground fault protection	41
Emergency stop devices	41
Safe torque off	42
Selecting the power cables	43
General rules	43
Alternative power cable types	44
Motor cable shield	44
Protecting the relay output contacts and attenuating disturbances in case of inductive loads	45
Considering the PELV requirements at sites above 2000 m (6562 ft)	45
Selecting the control cables	46
Relay cable	46
Control panel cable	46
Connection of a motor temperature sensor to the drive I/O	46
Routing the cables	46
Control cable ducts	47

Electrical installation

What this chapter contains	49
----------------------------------	----

Removing the cover assembly	49
Checking the insulation of the assembly	51
Drive	51
Supply cable	51
Motor and motor cable	51
Braking resistor assembly	51
Power cable connection	52
Power cable connection diagram	52
Procedure	53
Grounding the motor cable shield at the motor end	54
Installation of power cable clamp plates	55
Power cable connection – frame size A	56
Power cable connection – frame size B	57
Power cable connection – frame sizes C and D (connector covers removed)	58
DC connection	59
Installation of optional modules	61
Mechanical installation	61
Electrical installation	61
Connecting the control cables	62
Control connections to the JCU Control Unit	62
Jumpers	63
External power supply for the JCU Control Unit (XPOW)	63
DI6 (XDI:6) as a thermistor input	64
Drive-to-drive link (XD2D)	65
Safe torque off (XSTO)	66
Grounding and routing the control cables	66

Installation checklist

Checklist	69
-----------------	----

Maintenance

What this chapter contains	71
Safety	71
Maintenance intervals	71
Heatsink	72
Cooling fan	73
Fan replacement (Frames A and B)	73
Fan replacement (Frames C and D)	74
Reforming the capacitors	75
Other maintenance actions	75
Transferring the memory unit to a new drive module	75

Technical data

What this chapter contains	77
Ratings	77
Nominal ratings with 230 V AC supply	77

Nominal ratings with 400 V AC supply	.78
Nominal ratings with 460 V AC supply	.78
Nominal ratings with 500 V AC supply	.79
Symbols	.79
Derating	.79
Ambient temperature derating	.80
Altitude derating	.80
Low motor noise derating	.80
Deratings with 230 V AC supply in low motor noise mode	.80
Deratings with 400 V AC supply in low motor noise mode	.81
Deratings with 460 V AC supply in low motor noise mode	.81
Deratings with 500 V AC supply in low motor noise mode	.82
Symbols	.82
Dimensions and weights	.82
Cooling characteristics, noise levels	.83
Supply cable fuses	.84
AC input (supply) connection	.85
DC connection	.85
Motor connection	.86
JCU Control Unit	.86
Efficiency	.88
Cooling	.88
Degrees of protection	.88
Ambient conditions	.89
Materials	.89
Applicable standards	.90
CE marking	.91
Compliance with the European Low Voltage Directive	.91
Compliance with the European EMC Directive	.91
Definitions	.91
Compliance with EN 61800-3:2004, category C2	.91
Compliance with EN 61800-3:2004, category C3	.92
Compliance with EN 61800-3:2004, category C4	.92
Compliance with the Machinery Directive	.93
C-Tick marking	.94
UL marking	.94
UL checklist	.94
Patent protection in the US	.95

Mains chokes

What this chapter contains	.97
When is a mains choke required?	.97
Selection table	.97
Installation guidelines	.98
Connection diagram	.98

EMC filters

What this chapter contains	.99
----------------------------	-----

When is an EMC filter required?	99
Selection table	100
JFI-A1/JFI-B1 (Frame A/B, category C3) installation	101
Installation guidelines	101
Connection diagram	101
Mounting procedures	102
JFI-A1	102
JFI-B1	103
JFI-0x (Frames A...D, category C2) installation	104
Installation guidelines	104
Connection diagram	104

du/dt and common mode filtering

What this chapter contains	105
When is du/dt or common mode filtering required?	105
Filter types	106
du/dt filters	106
Common mode filters	107
Technical data	107
du/dt filters	107
Dimensions and weights	107
Degree of protection	107
Common mode filters	107
Installation	107

Resistor braking

What this chapter contains	109
Braking choppers and resistors with the ACS850-04	109
Braking choppers	109
Braking resistor selection	109
Chopper data table	110
Resistor selection table	111
Resistor installation and wiring	111
Contactor protection of drive	112
Braking circuit commissioning	112

Dimension drawings

What this chapter contains	113
Frame size A	114
Frame size B	115
Frame size C	116
Frame size D	117
Mains chokes (type CHK-0x)	118
EMC filters (type JFI-x1)	119
JFI-A1	119
JFI-B1	120

EMC filters (type JFI-0x)121
Braking resistors (type JBR-xx)123

Further information

Product and service inquiries125
Product training125
Providing feedback on ABB Drives manuals125
Document library on the Internet125

About this manual

What this chapter contains

This chapter describes the intended audience and contents of this manual. It contains a flowchart of steps in checking the delivery, installing and commissioning the drive. The flowchart refers to chapters/sections in this manual and other manuals.

Compatibility

The manual is compatible with ACS850-04 drive modules of frame sizes A to D.

Intended audience

This manual is intended for people who plan the installation, install, commission, use and service the drive. Read the manual before working on the drive. The reader is expected to know the fundamentals of electricity, wiring, electrical components and electrical schematic symbols.

This manual is written for readers worldwide. Both SI and imperial units are shown wherever appropriate.

Categorization according to the frame size

Some instructions, technical data and dimensional drawings which concern only certain frame sizes are marked with the symbol of the frame size A, B, C or D. The frame size is marked on the drive designation label. The frame size of each drive type is also indicated in the rating tables in chapter [Technical data](#).

Categorization according to the + code

The instructions, technical data and dimensional drawings which concern only certain optional selections are marked with + codes, e.g. +L500. The options included in the drive can be identified from the + codes visible on the type designation label of the drive. The + code selections are listed in chapter [Operation principle and hardware description](#) under [Type designation](#).

Contents

The chapters of this manual are briefly described below.

[Safety instructions](#) give safety instructions for the installation, commissioning, operation and maintenance of the drive.

[About this manual](#) lists the steps in checking the delivery and installing and commissioning the drive and refers to chapters/sections in this manual and other manuals for particular tasks.

Operation principle and hardware description describes the drive module.

Planning the cabinet assembly guides in planning the installation of the drive module into a user-defined cabinet.

Mechanical installation instructs how to place and mount the drive.

Planning the electrical installation instructs on the motor and cable selection, the protections and the cable routing.

Electrical installation instructs on how to wire the drive.

Installation checklist contains a list for checking the mechanical and electrical installation of the drive.

Maintenance lists periodic maintenance actions along with work instructions.

Technical data contains the technical specifications of the drive, e.g. the ratings, sizes and technical requirements, provisions for fulfilling the requirements for CE and other markings and warranty policy.

Mains chokes details the optional mains chokes available for the drive.

EMC filters details the EMC filtering options available for the drive.

du/dt and common mode filtering lists the du/dt and common mode filtering options available for the drive.

Resistor braking describes how to select, protect and wire braking resistors.

Dimension drawings contains the dimensional drawings of the drive and connected equipment.

Installation and commissioning flowchart

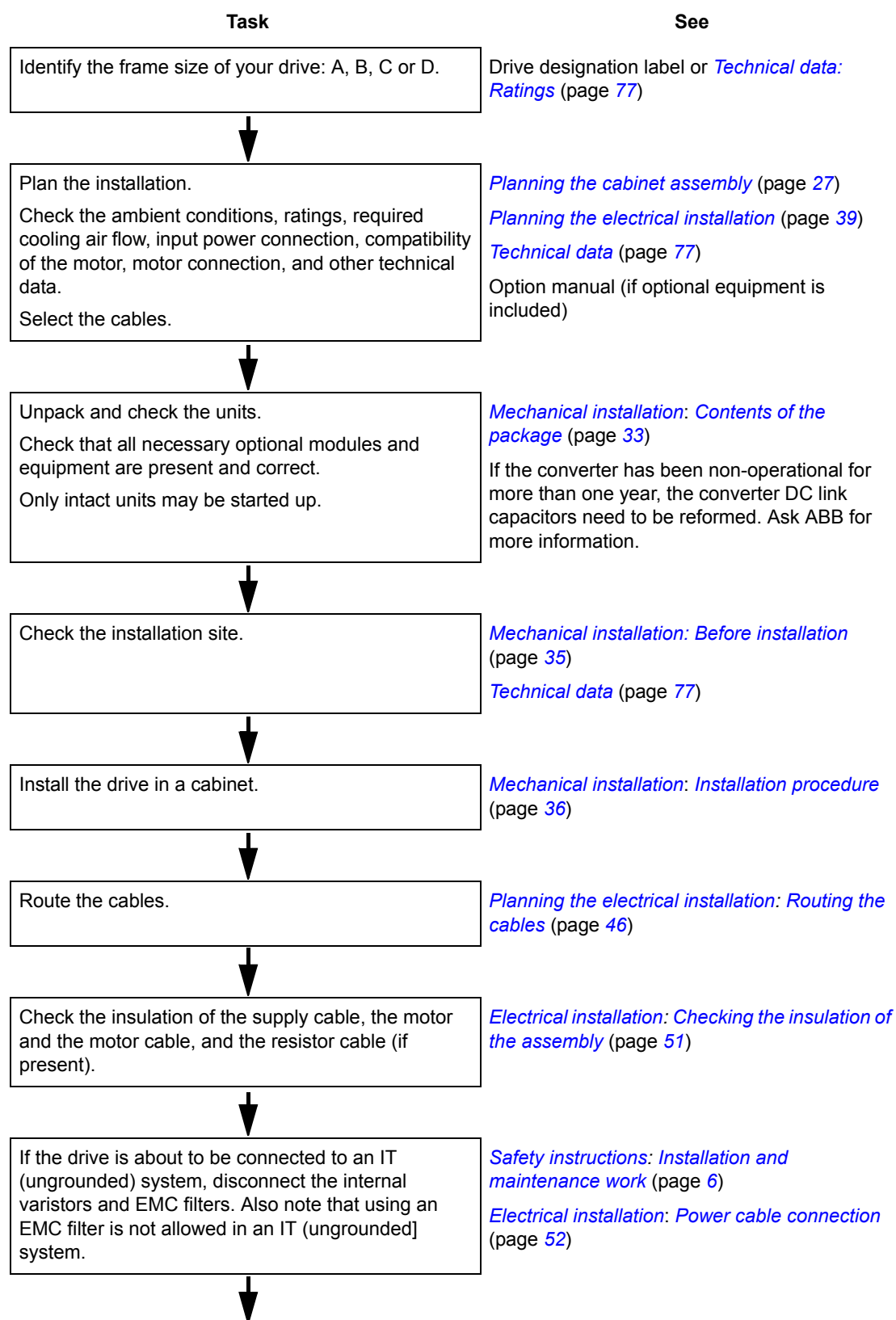

Task	See
Connect the power cables. Connect the control and the auxiliary control cables.	Electrical installation: Power cable connection: (page 52) and Connecting the control cables: (page 62) For optional equipment: Mains chokes (page 97) EMC filters (page 99) Resistor braking (page 109) Manuals for any optional equipment
↓ Check the installation.	Installation checklist (page 69)
↓ Commission the drive.	Appropriate <i>Firmware Manual</i>
↓ Commission the braking chopper if required.	Resistor braking (page 109)
↓ Operating of the drive: start, stop, speed control etc.	Appropriate <i>Firmware Manual</i>

Terms and abbreviations

Term/Abbreviation	Explanation
CHK-xx	Series of optional mains chokes for the ACS850.
EMC	Electromagnetic Compatibility.
FIO-01	Optional digital I/O extension for the ACS850.
FIO-11	Optional analog I/O extension for the ACS850.
FIO-21	Optional analog/digital I/O extension for the ACS850.
FEN-01	Optional TTL encoder interface for the ACS850.
FEN-11	Optional absolute encoder interface for the ACS850.
FEN-21	Optional resolver interface for the ACS850.
FEN-31	Optional HTL encoder interface for the ACS850.
FCAN-0x	Optional CANopen adapter for the ACS850.
FDNA-0x	Optional DeviceNet adapter for the ACS850.
FECA-0x	Optional EtherCAT® adapter for the ACS850.
FENA-0x	Optional Ethernet adapter for the ACS850. Supports the Ethernet/IP and Modbus/TCP protocols.
FLON-0x	Optional LONWORKS® adapter for the ACS850.
FPBA-0x	Optional PROFIBUS DP adapter for the ACS850.
Frame (size)	Size of the drive module. This manual deals with ACS850-04 frames A, B, C and D. To determine the frame size of a drive module, refer to the drive designation label attached to the drive, or the rating tables in chapter Technical data .
FSCA-0x	Optional Modbus/RTU adapter for the ACS850.
IGBT	Insulated Gate Bipolar Transistor; a voltage-controlled semiconductor type widely used in inverters due to their easy controllability and high switching frequency.
I/O	Input/Output.
JBR-xx	Series of optional braking resistors for the ACS850.
JCU	The control unit of the drive module. The JCU is installed on top of the power unit. The external I/O control signals are connected to the JCU, or optional I/O extensions mounted on it.
JFI-xx	Series of optional EMC filters for the ACS850.
JMU	The memory unit attached to the control unit of the drive.
JPU	Power unit ; see the definition below.
Power unit	Contains the power electronics and connections of the drive module. The JCU is connected to the power unit.
RFI	Radio-frequency interference.

Operation principle and hardware description

What this chapter contains

This chapter describes the operating principle and construction of the ACS850-04 drive module in short.

Operation principle

Main circuit

The main circuit of the drive module is shown below.

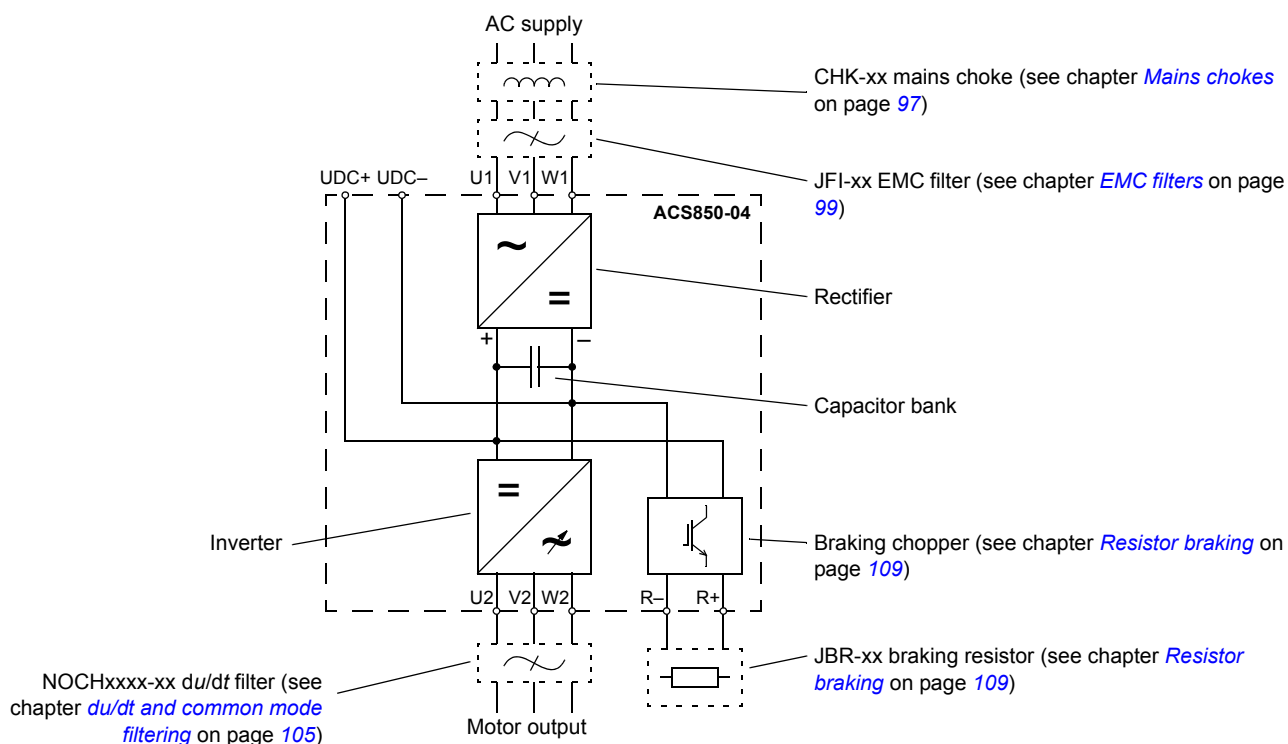

Component	Description
Braking chopper	Conducts the energy generated by a decelerating motor from the DC bus to a braking resistor. The braking chopper is built in the ACS850-04; braking resistors are external options.
Braking resistor	Dissipates the regenerative energy by converting it to heat.
Capacitor bank	Energy storage which stabilizes the intermediate circuit DC voltage.
du/dt filter	See page 105 .
Inverter	Converts the DC voltage to AC voltage and vice versa. The motor is controlled by switching the IGBTs of the inverter.
Mains choke	See page 97 .
EMC filter	See page 99 .
Rectifier	Converts the three-phase AC voltage to DC voltage.

Motor control

The motor control is based on direct torque control. Two phase currents and DC link voltage are measured and used for the control. The third phase current is measured for earth fault protection.

Product overview

The ACS850-04 is an air-cooled IP20 drive module for controlling AC motors. It is to be installed into a cabinet by the customer.

The ACS850-04 is available in several frame sizes depending on output power. All frame sizes use the same control unit (type JCU).

Layout

Drive module, frame size A

JCU Control Unit with cover assembly removed

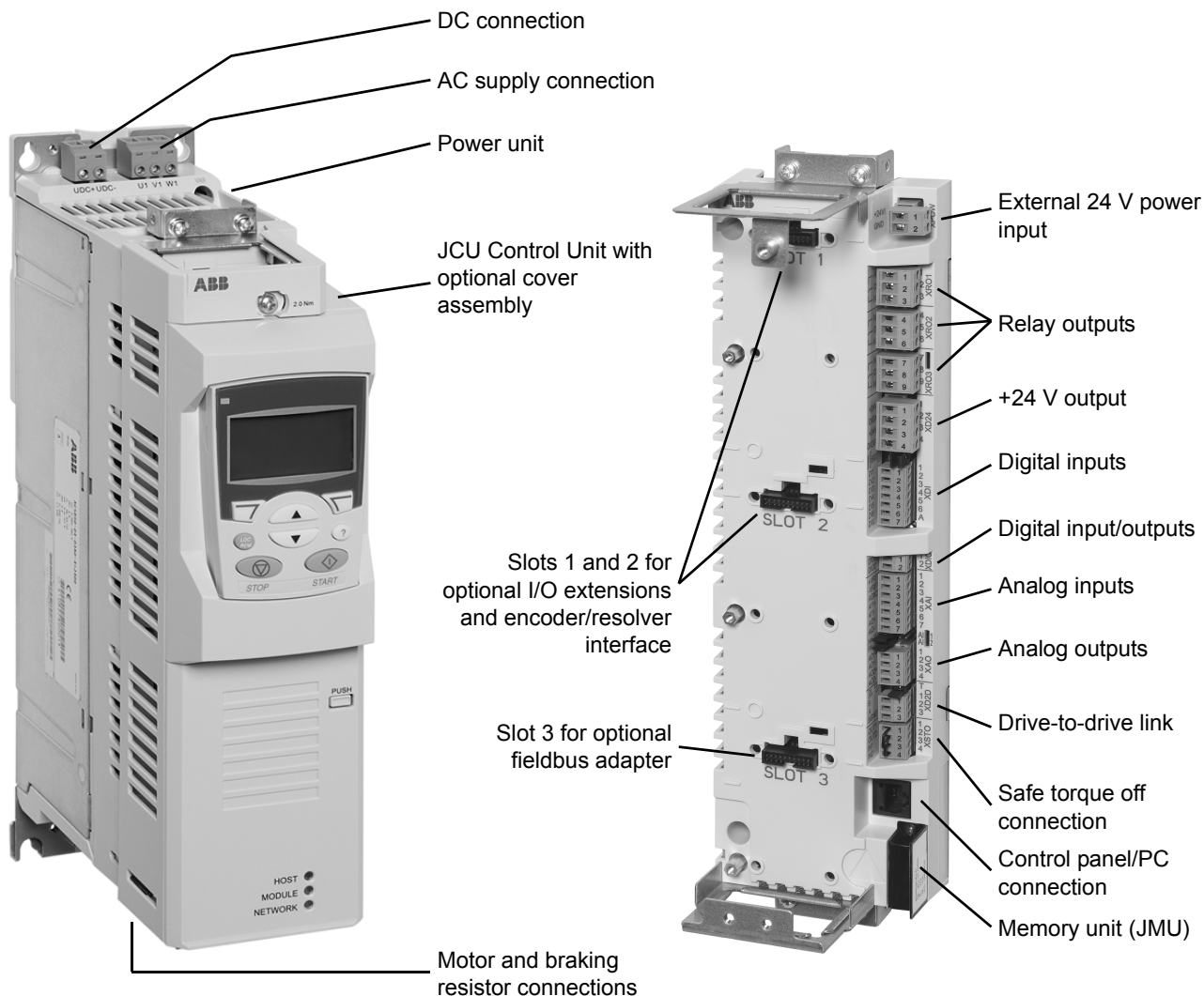

Power connections and control interfaces

The diagram shows the power connections and control interfaces of the drive.

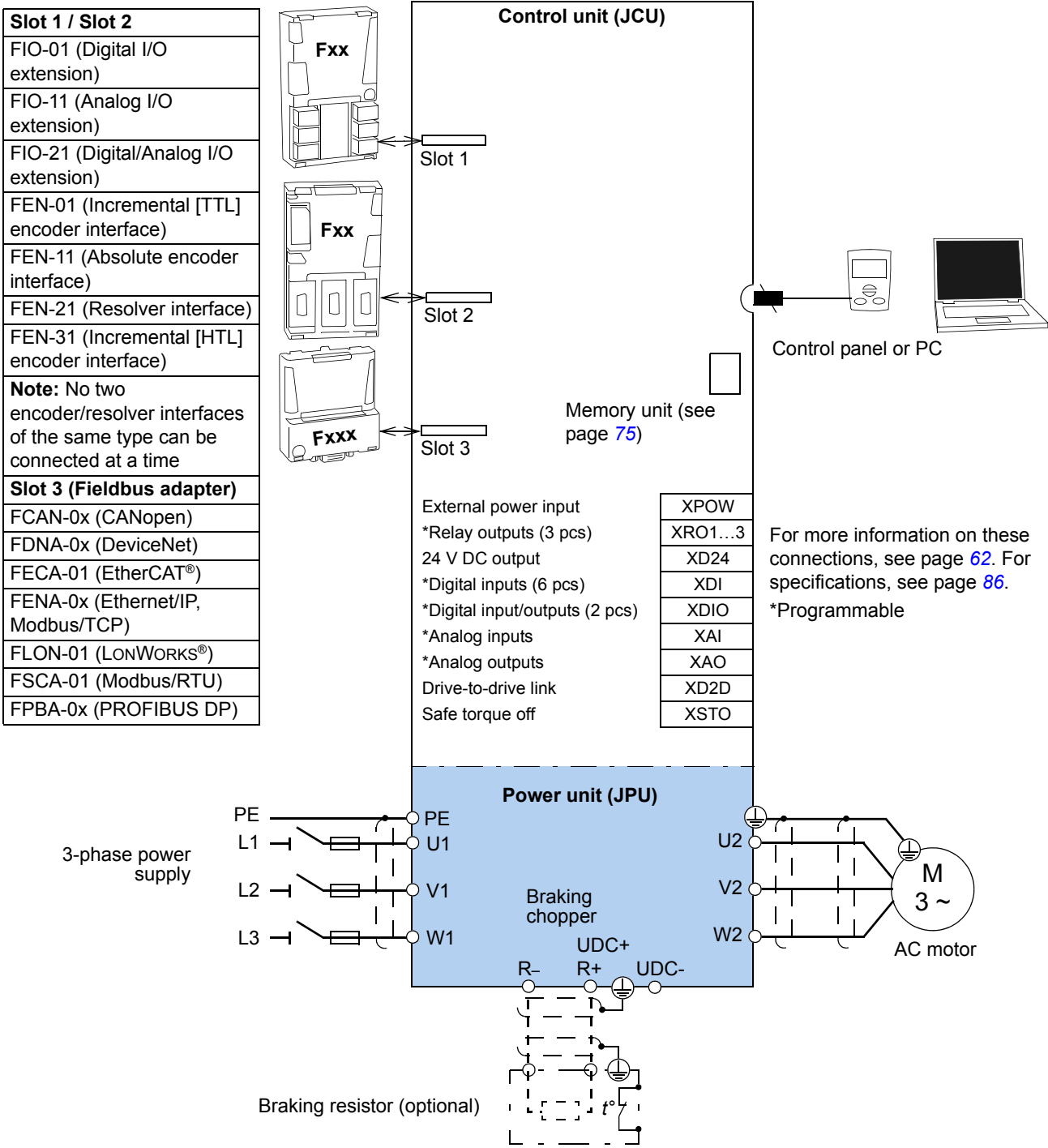

Type designation

The type designation contains information on the specifications and configuration of the drive. The first digits from left express the basic configuration (e.g. ACS850-04-04A8-5). The optional selections are given thereafter, preceded by + signs (e.g. +L501). The main selections are described below. Not all selections are necessarily available for all types; refer to *ACS850 Ordering Information*, available on request.

See also section [Delivery check and drive module identification](#) on page 35.

Selection	Alternatives	
Product series	ACS850 product series	
Type	04	Drive module. When no options are selected: IP20 (UL Open Type), plain front cover, no control panel, no mains choke (frames A and B), internal mains choke (frames C and D), no EMC filter, internal braking chopper, coated boards, Safe torque off, Standard Control Program, <i>Quick Installation Guide</i> (multilingual), <i>Quick Start-up Guide</i> (multilingual), CD containing all manuals
Size	Refer to Technical data: Ratings .	
Voltage range	2 5	200...240 V 380...500 V
+ options		
Filters	E...	+E200: EMC filter, C3, 2nd Environment, Unrestricted (Earthed network) (External with frames A and B, internal with frames C and D)
Control panel and front cover options	J...	+0C168: No drive module front cover, no control panel +J400: Control panel mounted on drive module front cover +J410: Control panel with door mounting platform kit including 3 m cable +J414: Control panel mounting platform on drive module (no control panel included)
Fieldbus	K...	+K451: FDNA-01 DeviceNet adapter +K452: FLON-01 LonWorks® adapter +K454: FPBA-01 PROFIBUS DP adapter +K457: FCAN-01 CANopen adapter +K458: FSCA-01 Modbus/RTU adapter +K466: FENA-01 Ethernet adapter (Ethernet/IP, Modbus/TCP) +K469: FECA-01 EtherCAT® adapter
I/O extensions and feedback interfaces	L...	+L500: FIO-11 analog I/O extension +L501: FIO-01 digital I/O extension +L502: FEN-31 HTL encoder interface +L516: FEN-21 resolver interface +L517: FEN-01 TTL encoder interface +L518: FEN-11 absolute encoder interface +L519: FIO-21 analog/digital I/O extension
Programs	N...	+N5050: Crane control program Note: The following technology library is required with the Crane control program: +N3050: Crane technology library
Specialities	P... Q	+P904: Extended warranty +Q971: ATEX-certified safe disconnection function

Selection	Alternatives	
Printed hardware and firmware manuals in specified language (English manuals may be delivered even if another language is selected)	R...	+R700: English +R701: German +R702: Italian +R703: Dutch +R704: Danish +R705: Swedish +R706: Finnish +R707: French +R708: Spanish +R709: Portuguese +R711: Russian +R714: Turkish

00579470

Ordering information

For a complete listing of options and accessories available for the ACS850-04, refer to *ACS850 Ordering Information* (available on request).

Planning the cabinet assembly

What this chapter contains

This chapter guides in planning the installation of a drive module into a user-defined cabinet. The issues discussed are essential for safe and trouble-free use of the drive system.

Note: The installation examples in this manual are provided only to help the installer in designing the installation. **Please note that the installation must, however, always be designed and made according to applicable local laws and regulations.** ABB does not assume any liability whatsoever for any installation which breaches the local laws and/or other regulations.

Cabinet construction

The cabinet frame must be sturdy enough to carry the weight of the drive components, control circuitry and other equipment installed in it.

The cabinet must protect the drive module against contact and meet the requirements for dust and humidity (see chapter [Technical data](#)).

Disposition of the devices

For easy installation and maintenance, a spacious layout is recommended. Sufficient cooling air flow, obligatory clearances, cables and cable support structures all require space.

For a layout example, see section [Cooling and degrees of protection](#) below.

Grounding of mounting structures

Make sure all cross-members or shelves on which drive system components are mounted are properly grounded and the connecting surfaces left unpainted.

Note: Ensure that the components are properly grounded through their fastening points to the installation base.

Note: It is recommended that the EMC filter (if present) and the drive module be mounted on the same mounting plate.

Note: EMC filters of type JFI-x1 mounted directly above the drive module do not increase the free space requirements. (For EMC filters of type JFI-0x, see the dimension drawing of the filters on page [121](#).)

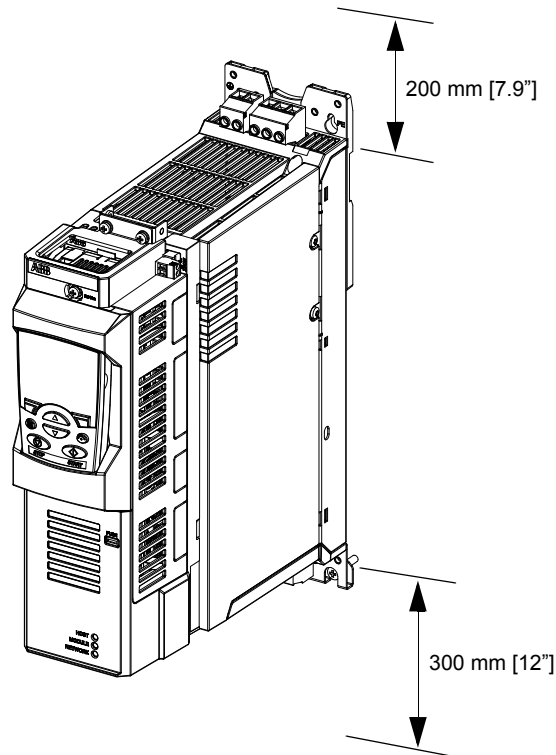

The temperature of the cooling air entering the unit must not exceed the maximum allowed ambient temperature (see [Ambient conditions](#) in chapter [Technical data](#)). Consider this when installing heat-generating components (such as other drives, mains chokes and braking resistors) nearby.

Cooling and degrees of protection

The cabinet must have enough free space for the components to ensure sufficient cooling. Observe the minimum clearances given for each component.

The air inlets and outlets must be equipped with gratings that

- guide the air flow
- protect against contact
- prevent water splashes from entering the cabinet.

The drawing below shows two typical cabinet cooling solutions. The air inlet is at the bottom of the cabinet, while the outlet is at the top, either on the upper part of the door or on the roof.

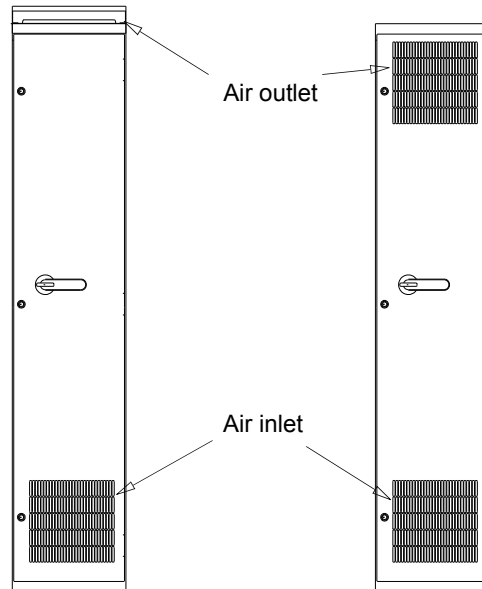

Arrange the cooling of the modules so that the requirements given in chapter [Technical data](#) are met:

- cooling air flow
Note: The values in [Technical data](#) apply to continuous nominal load. If the load is less than nominal, less cooling air is required.
- allowed ambient temperature.

Make sure the air inlets and outlets are sufficient in size. Please note that in addition to the power loss of the drive module, the heat dissipated by cables and other additional equipment must also be ventilated.

The internal cooling fans of the modules are usually sufficient to keep the component temperatures low enough in IP22 cabinets.

In IP54 cabinets, thick filter mats are used to prevent water splashes from entering the cabinet. This entails the installation of additional cooling equipment, such as a hot air exhaust fan.

The installation site must be sufficiently ventilated.

Preventing the recirculation of hot air

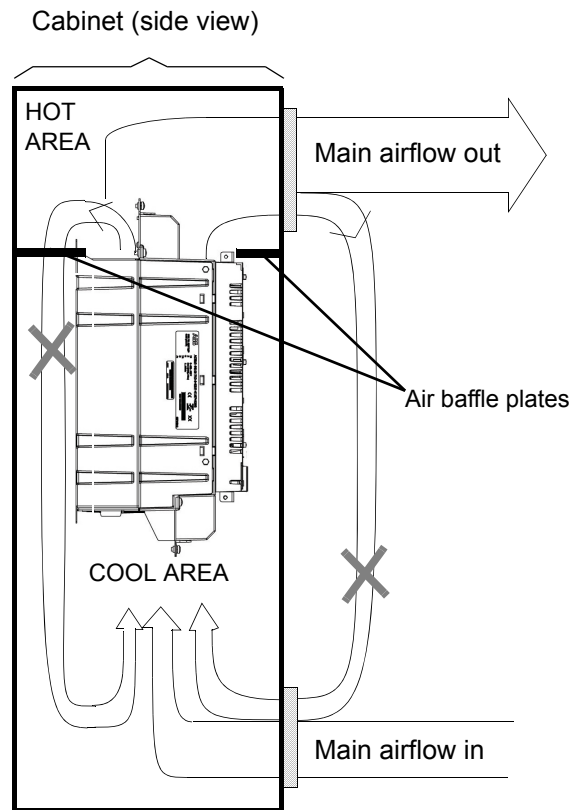

Outside the cabinet

Prevent hot air circulation outside the cabinet by leading the outcoming hot air away from the area where the inlet air to the cabinet is taken. Possible solutions are listed below:

- gratings that guide air flow at the air inlet and outlet
- air inlet and outlet at different sides of the cabinet
- cool air inlet in the lower part of the front door and an extra exhaust fan on the roof of the cabinet.

Inside the cabinet

Prevent hot air circulation inside the cabinet with leak-proof air baffle plates. No gaskets are usually required.

Cabinet heaters

Use a cabinet heater if there is a risk of condensation in the cabinet. Although the primary function of the heater is to keep the air dry, it may also be required for heating at low temperatures. When placing the heater, follow the instructions provided by its manufacturer.

Mechanical installation

Contents of the package

The drive is delivered in a cardboard box. To open, remove any banding and lift the top off the box.



efesotomasyon.com

The box contains:

- ACS850-04 drive module, with factory-installed options
- three cable clamp plates (two for power cabling, one for control cabling) with screws
- screw-type terminal blocks to be attached to the headers on the JCU Control Unit and the power unit
- EMC filter (+E200) if ordered (with frames A and B only)
- control panel mounting kit (+J410) if ordered
- Printed Quick Guides, printed manuals if ordered, manuals CD.

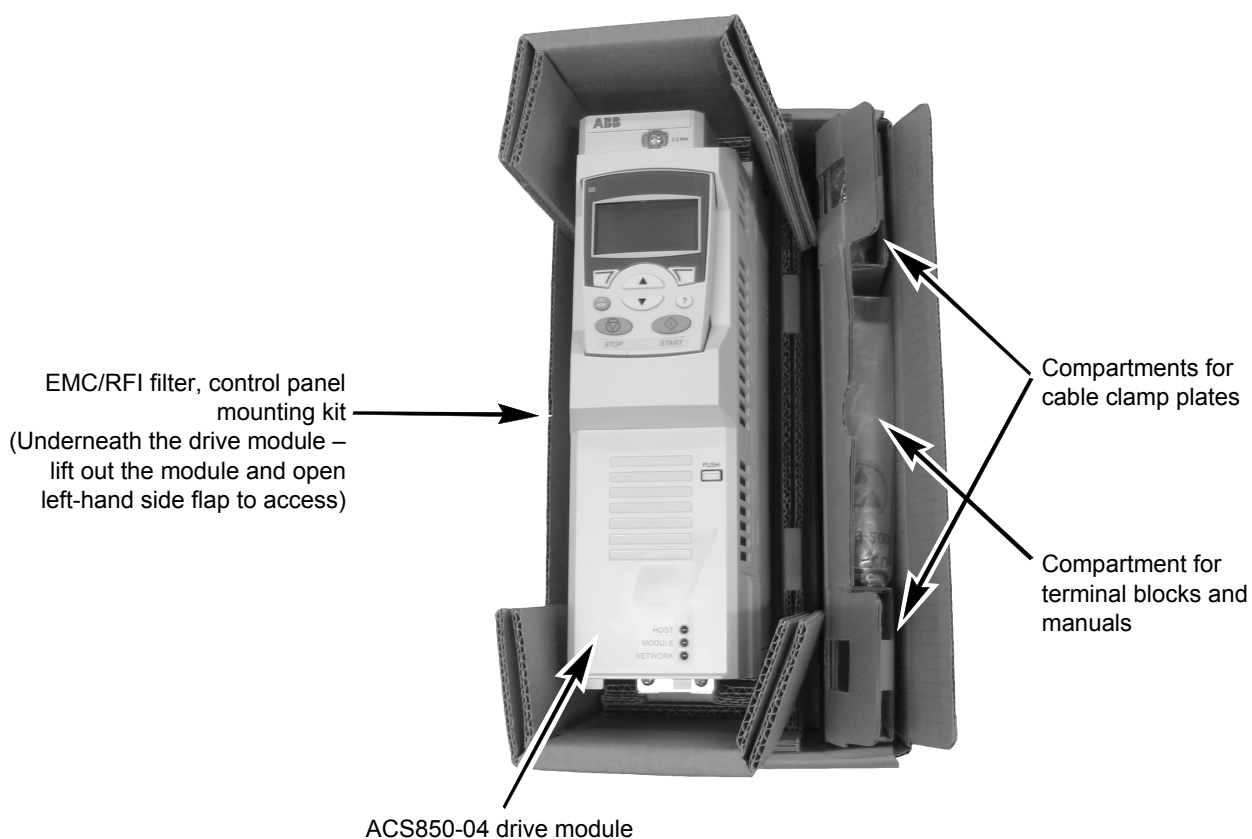

Delivery check and drive module identification

Check that there are no signs of damage. Before attempting installation and operation, check the information on the type designation label of the drive module to verify that the unit is of the correct type. The label is located on the left-hand side of the drive module.

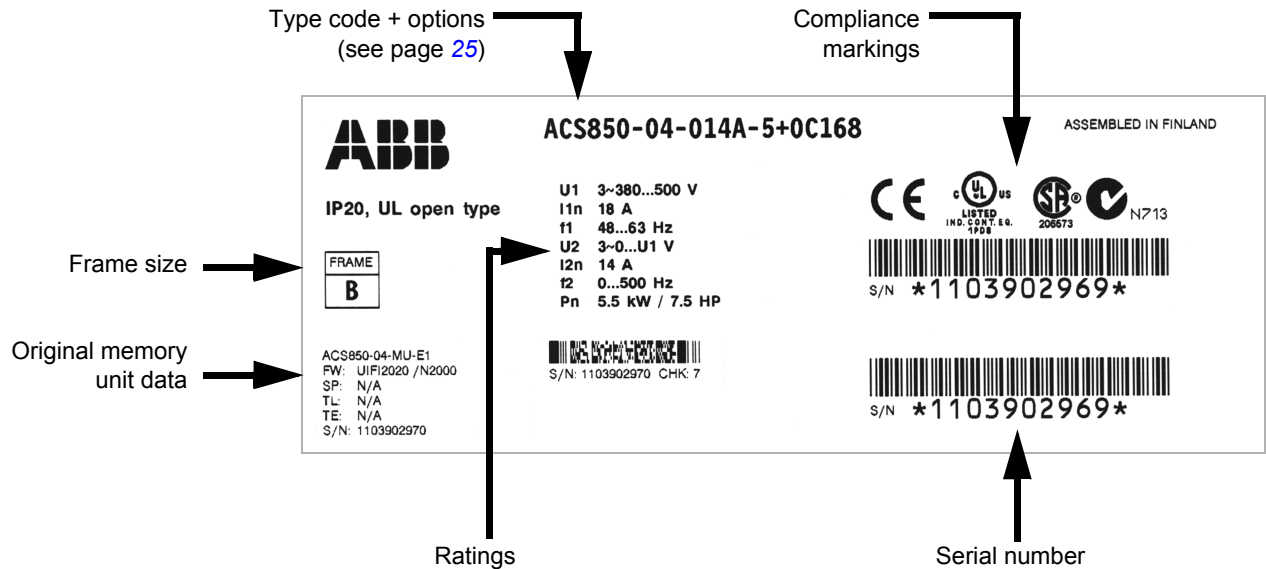

The first digit of the serial number refers to the manufacturing plant. The 2nd and 3rd digit indicate the year of manufacture, while the 4th and 5th digits indicate the week. Digits 6 to 10 are a running integer starting every week at 00001.

Before installation

Check the installation site according to the requirements below. Refer to [Dimension drawings](#) for frame details.

Requirements for the installation site

See [Technical data](#) for the allowed operation conditions of the drive.

The ACS850-04 is to be mounted in an upright position. The wall the drive is to be mounted on must be as even as possible, of non-flammable material and strong enough to carry the weight of the drive. The floor/material below the drive must be non-flammable.

Installation procedure

Direct wall mounting

1. Mark the locations for the four holes. The mounting points are shown in [Dimension drawings](#).
2. Fix the screws or bolts to the marked locations.
3. Position the drive onto the screws on the wall. **Note:** Only lift the drive by its chassis.
4. Tighten the screws.

DIN rail mounting (Frames A and B only)

1. Click the drive to the rail as shown in Figure *a* below. To detach the drive, press the release lever on top of the drive as shown in Figure *b*.
2. Fasten the lower edge of the drive to the mounting base through the two fastening points.

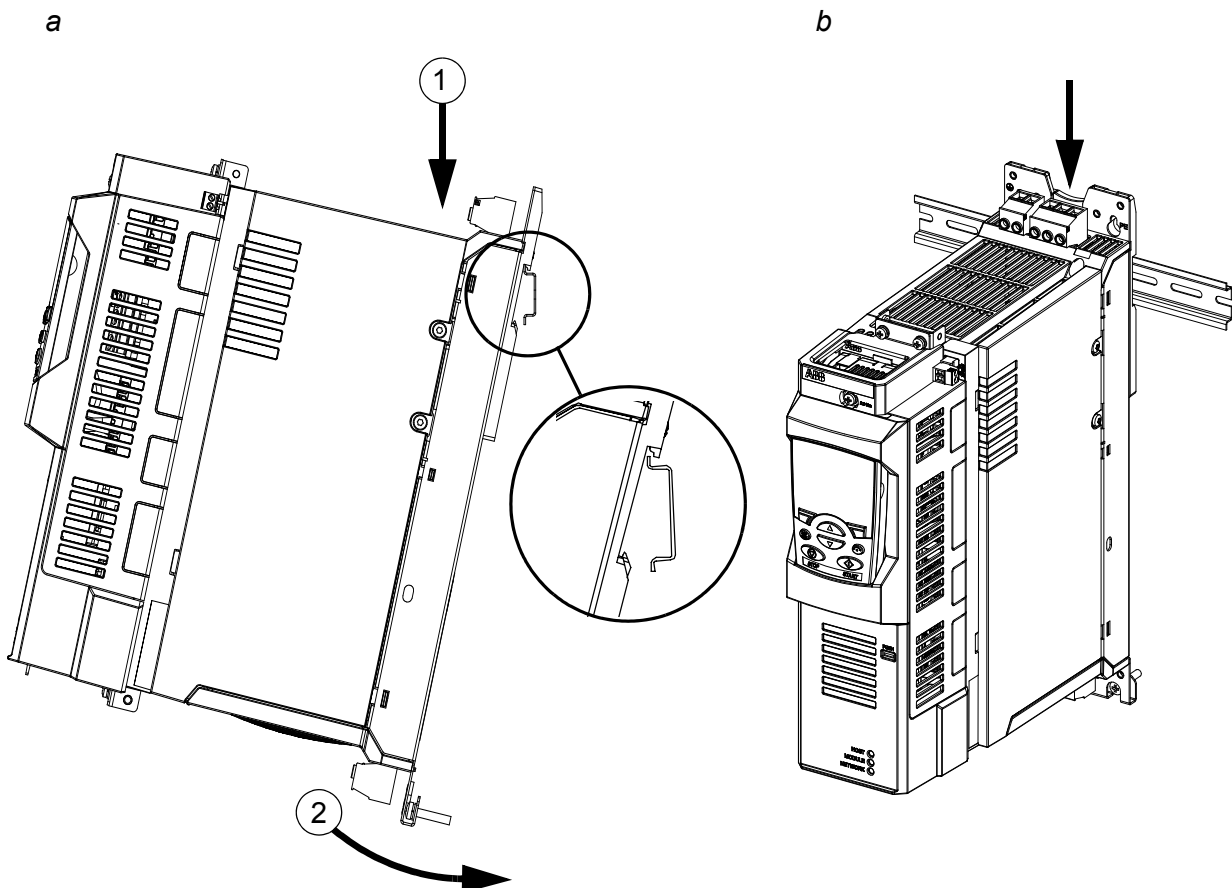

Mains choke installation

See chapter [Mains chokes](#) on page 97.

EMC filter installation

See chapter [EMC filters](#) on page 99.

Braking resistor installation

See chapter [Resistor braking](#) on page 109.

Planning the electrical installation

What this chapter contains

This chapter contains the instructions that you must follow when selecting the motor, cables, protections, cable routing and way of operation for the drive. If the recommendations given by ABB are not followed, the drive may experience problems that the warranty does not cover.

Note: The installation must always be designed and made according to applicable local laws and regulations. ABB does not assume any liability whatsoever for any installation which breaches the local laws and/or other regulations.

Motor selection

Select the (3-phase AC induction) motor according to the rating table in chapter [Technical data](#). The table lists the typical motor power for each drive type.

Only one permanent magnet synchronous motor can be connected to the inverter output. It is recommended to install a safety switch between the permanent magnet motor and the drive output in order to isolate the motor from the drive during maintenance work on the drive.

Supply connection

Use a fixed connection to the AC power line.



WARNING! As the leakage current of the device typically exceeds 3.5 mA, a fixed installation is required according to IEC 61800-5-1.

Supply disconnecting device

Install a hand-operated input disconnecting device (disconnecting means) between the AC power source and the drive. The disconnecting device must be of a type that can be locked to the open position for installation and maintenance work.

Europe

If the drive is used in an application which must meet the European Union Machinery Directive according to standard EN 60204-1 Safety of Machinery, the disconnecting device must be one of the following types:

- a switch-disconnector of utilization category AC-23B (EN 60947-3)
- a disconnector that has an auxiliary contact that in all cases causes switching devices to break the load circuit before the opening of the main contacts of the disconnector (EN 60947-3)

- a circuit breaker suitable for isolation in accordance with EN 60947-2.

Other regions

The disconnecting means must conform to the applicable safety regulations.

Thermal overload and short circuit protection

Thermal overload protection

The drive protects itself and the input and motor cables against thermal overload when the cables are dimensioned according to the nominal current of the drive. No additional thermal protection devices are needed.



WARNING! If the drive is connected to multiple motors, a separate thermal overload switch or a circuit breaker must be used for protecting each cable and motor. These devices may require a separate fuse to cut off the short-circuit current.

Protection against short-circuit in motor cable

The drive protects the motor cable and the motor in a short-circuit situation when the motor cable is dimensioned according to the nominal current of the drive. No additional protection devices are needed.

Protection against short-circuit in the supply cable or the drive

Protect the supply cable with fuses or circuit breakers. Fuse recommendations are given in chapter [Technical data](#). When placed at the distribution board, standard IEC gG fuses or UL type T fuses will protect the input cable in short-circuit situations, restrict drive damage and prevent damage to adjoining equipment in case of a short circuit inside the drive.

Operating time of the fuses and circuit breakers

Check that the operating time of the fuse is below 0.5 seconds. The operating time depends on the type, the supply network impedance, and the cross-sectional area, material and length of the supply cable. US fuses must be of the “non-time delay” type.

Circuit breakers

The protective characteristics of circuit breakers depend on the supply voltage as well as the type and construction of the breakers. There are also limitations pertaining to the short-circuit capacity of the supply network. Your local ABB representative can help you in selecting the breaker type when the supply network characteristics are known.

Motor thermal protection

According to regulations, the motor must be protected against thermal overload and the current must be switched off when overloading is detected. The drive includes a motor thermal protection function that protects the motor and switches off the current when necessary. Depending on a drive parameter value, the function either monitors a calculated temperature value (based on a motor thermal model) or an actual temperature indication given by motor temperature sensors. The user can tune the thermal model further by feeding in additional motor and load data.

PTC sensors can be connected directly to the ACS850-04. See page 64 in this manual, and the appropriate *Firmware Manual* for the parameter settings concerning motor thermal protection.

Ground fault protection

The drive is equipped with an internal ground fault protective function to protect the unit against ground faults in the motor and the motor cable. This is not a personal safety or a fire protection feature. The ground fault protective function can be disabled with a parameter, refer to the appropriate *Firmware Manual*.

The optional EMC filter includes capacitors connected between the main circuit and the frame. These capacitors and long motor cables increase the ground leakage current and may cause fault current circuit breakers to function.

Emergency stop devices

For safety reasons, install the emergency stop devices at each operator control station and at other operating stations where emergency stop may be needed.

Note: Pressing the stop key on the control panel of the drive does not generate an emergency stop of the motor or separate the drive from dangerous potential.

Safe torque off

The drive supports the Safe torque off function (STO) according to standards EN 61800-5-2:2007; EN ISO 13849-1:2008, IEC 61508, IEC 61511:2004 and EN 62061:2005. The function also corresponds to prevention of unexpected start-up of EN 1037.

The Safe torque off function disables the control voltage of the power semiconductors of the drive output stage, thus preventing the inverter from generating the voltage required to rotate the motor (see the diagram below). By using this function, short-time operations (like cleaning) and/or maintenance work on non-electrical parts of the machinery can be performed without switching off the power supply to the drive.

Start up and validate the Safe torque off function according to *Safe torque off function for ACSM1, ACS850 and ACQ810 drives application guide* (3AFE68929814 [English]). The manual includes the safety data for the function.

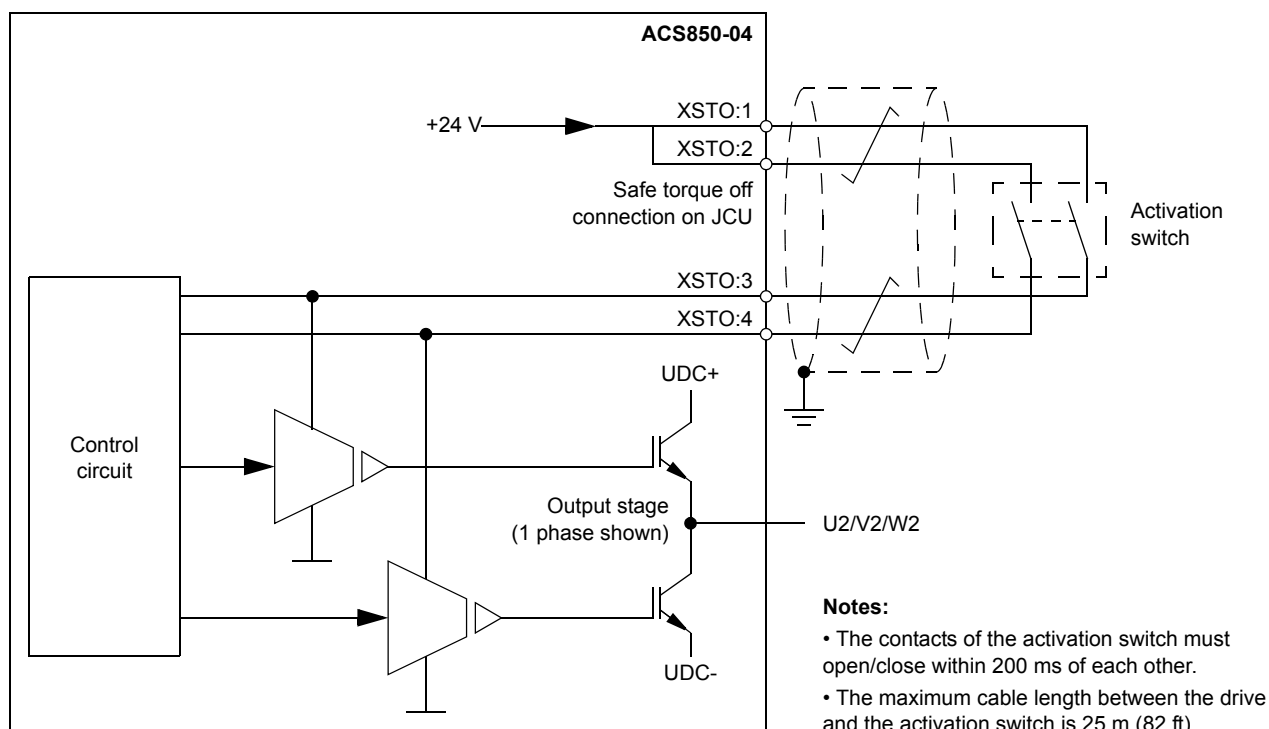

WARNING! The Safe torque off function does not disconnect the voltage of the main and auxiliary circuits from the drive. Therefore maintenance work on electrical parts of the drive or the motor can only be carried out after isolating the drive system from the main supply.

Note: It is not recommended to stop the drive by using the Safe torque off function. If a running drive is stopped by using the function, the drive will trip and stop by coasting. If this causes danger or is not acceptable, the drive and machinery must be stopped using the appropriate stopping mode before using the Safe torque off function.

Note concerning permanent magnet motor drives in case of a multiple IGBT power semiconductor failure: In spite of the activation of the Safe torque off function, the drive system can produce an alignment torque which maximally rotates the motor shaft by $180/p$ degrees. p denotes the pole pair number.

Selecting the power cables

General rules

Dimension the supply (input power) and motor cables **according to local regulations**.

- The cable must be able to carry the drive load current. See chapter *Technical data* for the rated currents.
- The cable must be rated for at least 70 °C (US: 75 °C [167 °F]) maximum permissible temperature of conductor in continuous use.
- The inductance and impedance of the PE conductor/cable (grounding wire) must be rated according to permissible touch voltage appearing under fault conditions (so that the fault point voltage will not rise excessively when a ground fault occurs).
- 600 V AC cable is accepted for up to 500 V AC.
- Refer to chapter *Technical data* for EMC requirements.

Symmetrical shielded motor cable must be used (see the figure below) to meet the EMC requirements of the CE and C-tick marks.

A four-conductor system is allowed for input cabling, but shielded symmetrical cable is recommended. To operate as a protective conductor, the shield conductivity must be as follows when the protective conductor is made of the same metal as the phase conductors:

Cross-sectional area of one phase conductor (S)	Minimum cross-sectional area of protective conductor (S _p)
$S \leq 16 \text{ mm}^2$	S
$16 \text{ mm}^2 < S \leq 35 \text{ mm}^2$	16 mm ²
$35 \text{ mm}^2 < S$	S/2

Compared to a four-conductor system, the use of symmetrical shielded cable reduces electromagnetic emission of the whole drive system as well as motor bearing currents and wear.

The motor cable and its PE pigtail (twisted shield) should be kept as short as possible in order to reduce electromagnetic emission, as well as stray currents outside the cable and capacitive current.

Alternative power cable types

Power cable types that can be used with the drive are represented below.

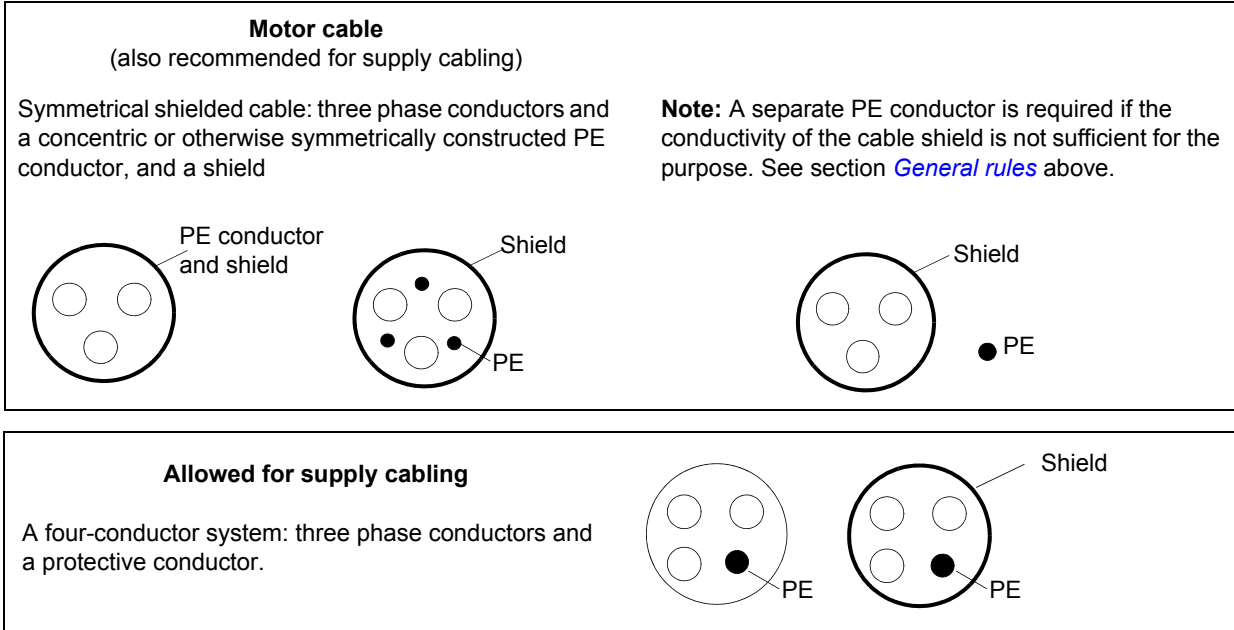

Motor cable shield

To function as a protective conductor, the shield must have the same cross-sectional area as a phase conductor when they are made of the same metal.

To effectively suppress radiated and conducted radio-frequency emissions, the shield conductivity must be at least 1/10 of the phase conductor conductivity. The requirements are easily met with a copper or aluminium shield. The minimum requirement of the motor cable shield of the drive is shown below. It consists of a concentric layer of copper wires with an open helix of copper tape. The better and tighter the shield, the lower the emission level and the bearing currents.

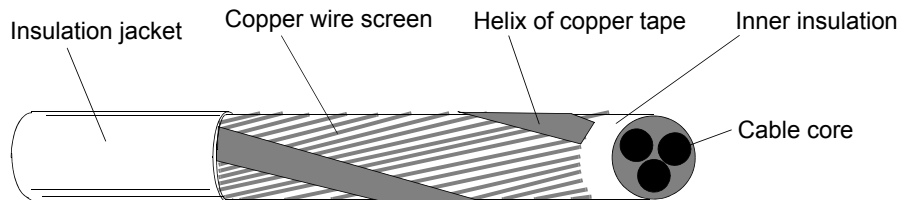

Protecting the relay output contacts and attenuating disturbances in case of inductive loads

Inductive loads (relays, contactors, motors) cause voltage transients when switched off.

The relay outputs on the drive are protected with varistors (250 V) against overvoltage peaks. In addition, it is highly recommended to equip inductive loads with noise attenuating circuits (varistors, RC filters [AC] or diodes [DC]) in order to minimize the electromagnetic emissions at switch-off. If not suppressed, the disturbances may connect capacitively or inductively to other conductors in the control cable and form a risk of malfunction in other parts of the system.

Install the protective component as close to the inductive load as possible, not at the relay output.

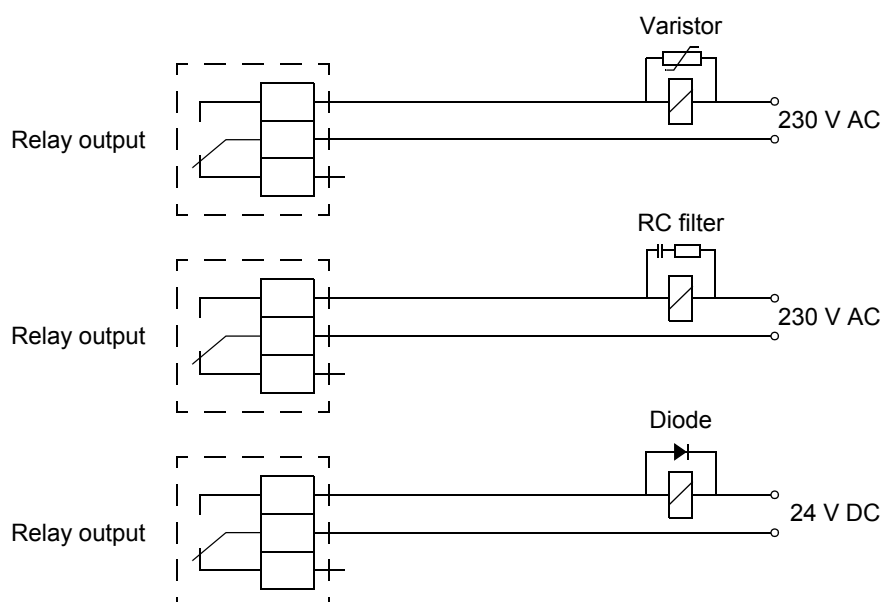

Considering the PELV requirements at sites above 2000 m (6562 ft)

The relay outputs of the drive do not fulfill the Protective Extra Low Voltage (PELV) requirements at installation sites above 4000 meters (13123 feet) if used with a voltage greater than 48 V. At installation sites between 2000 meters (6562 feet) and 4000 meters (13123 feet), PELV requirements are not fulfilled if one or two relay outputs are used with a voltage greater than 48 V and the remaining relay output(s) are used with a voltage lower than 48 V.

Selecting the control cables

It is recommended that all control cables be shielded.

Double-shielded twisted pair cable is recommended for analog signals. For pulse encoder cabling, follow the instructions given by the encoder manufacturer. Use one individually-shielded pair for each signal. Do not use a common return for different analog signals.

Double-shielded cable is the best alternative for low-voltage digital signals but single-shielded twisted multipair cable (Figure *b*) is also usable.

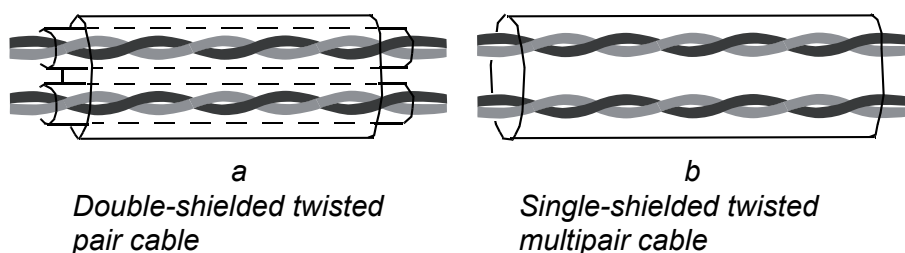

Run analog and digital signals in separate cables.

Relay-controlled signals, providing their voltage does not exceed 48 V, can be run in the same cables as digital input signals. It is recommended that the relay-controlled signals be run as twisted pairs.

Never mix 24 V DC and 115/230 V AC signals in the same cable.

Relay cable

The cable type with braided metallic screen (e.g. ÖLFLEX by Lapp Kabel, Germany) has been tested and approved by ABB.

Control panel cable

The cable connecting the control panel to the drive must not exceed 3 metres in length. The cable type tested and approved by ABB is used in control panel option kits.

Connection of a motor temperature sensor to the drive I/O

See page [64](#).

Routing the cables

Route the motor cable away from other cable routes. Motor cables of several drives can be run in parallel installed next to each other. It is recommended that the motor cable, input power cable and control cables be installed on separate trays. Avoid long parallel runs of motor cables with other cables in order to decrease electromagnetic interference caused by the rapid changes in the drive output voltage.

Where control cables must cross power cables make sure they are arranged at an angle as near to 90 degrees as possible. Do not run extra cables through the drive.

The cable trays must have good electrical bonding to each other and to the grounding electrodes. Aluminium tray systems can be used to improve local equalizing of potential.

A diagram of the cable routing is below.

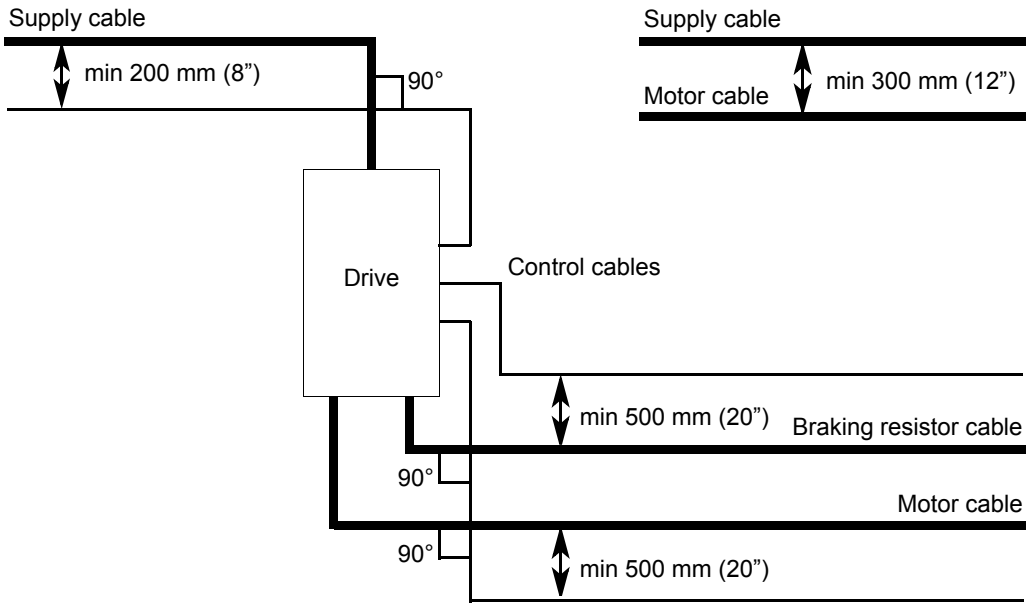

Control cable ducts

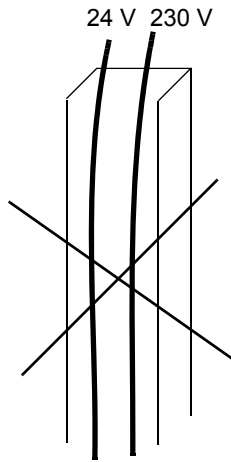

Not allowed unless the 24 V cable is insulated for 230 V or insulated with an insulation sleeving for 230 V.

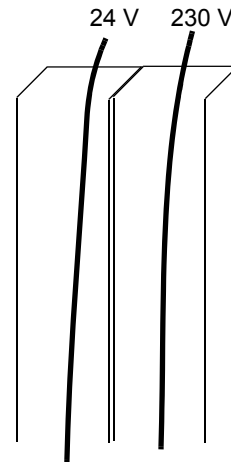

Lead 24 V and 230 V control cables in separate ducts inside the cabinet.

Electrical installation

What this chapter contains

This chapter describes the electrical installation procedure of the drive.



WARNING! The work described in this chapter may only be carried out by a qualified electrician. Follow the [Safety instructions](#) on the first pages of this manual. Ignoring the safety instructions can cause injury or death.

Make sure that the drive is disconnected from the supply (input power) during installation. If the drive is already connected to the supply, wait for 5 minutes after disconnecting the input power.

Removing the cover assembly

The cover assembly needs to be removed before the installation of optional modules and the connection of control cabling. Follow this procedure to remove the cover assembly. The numbers refer to the illustrations below.

- Press the tab (1) slightly with a screwdriver.
- Slide the lower cover plate slightly downwards and pull it out (2).
- Disconnect the panel cable (3) if present.
- Remove the screw (4) at the top of the cover assembly.
- Carefully pull the lower part of the base outwards by the two tabs (5).

Refit the cover in reverse order to the above procedure.

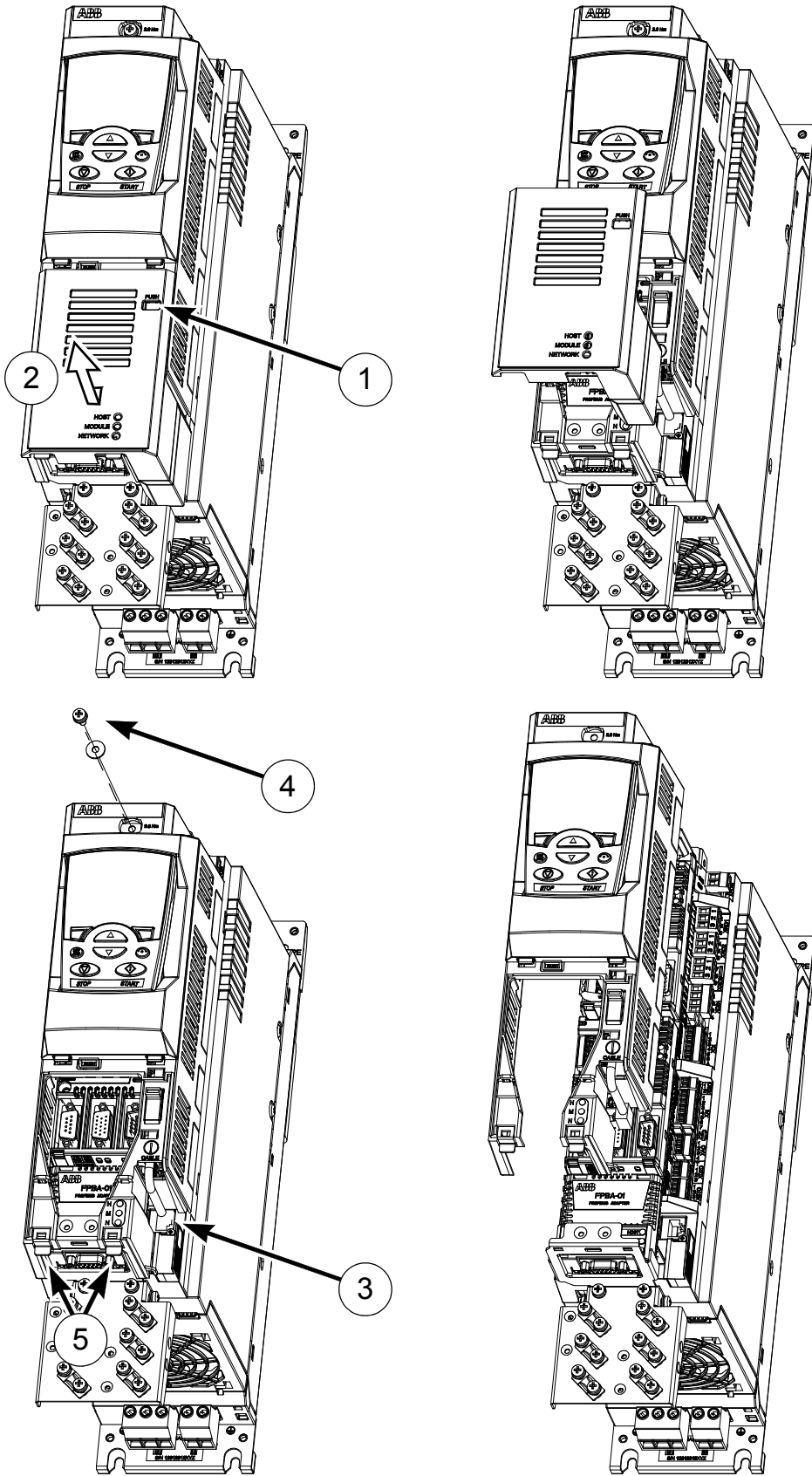

Checking the insulation of the assembly

Drive

Do not make any voltage tolerance or insulation resistance tests (e.g. hi-pot or megger) on any part of the drive as testing can damage the drive. Every drive has been tested for insulation between the main circuit and the chassis at the factory. Also, there are voltage-limiting circuits inside the drive which cut down the testing voltage automatically.

Supply cable

Check the insulation of the supply (input) cable according to local regulations before connecting to the drive.

Motor and motor cable

Check the insulation of the motor and motor cable as follows:

1. Check that the motor cable is connected to the motor, and disconnected from the drive output terminals U2, V2 and W2.
2. Measure the insulation resistance between each phase conductor and the Protective Earth conductor using a measuring voltage of 500 V DC. The insulation resistance of an ABB motor must exceed 100 Mohm (reference value at 25 °C or 77 °F). For the insulation resistance of other motors, please consult the manufacturer's instructions. **Note:** Moisture inside the motor casing will reduce the insulation resistance. If moisture is suspected, dry the motor and repeat the measurement.

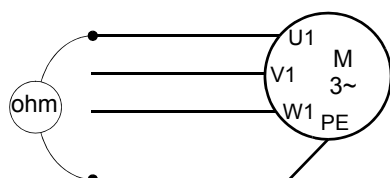

Braking resistor assembly

Check the insulation of the braking resistor assembly (if present) as follows:

1. Check that the resistor cable is connected to the resistor, and disconnected from the drive output terminals R+ and R-.
2. At the drive end, connect the R+ and R- conductors of the resistor cable together. Measure the insulation resistance between the combined conductors and the PE conductor by using a measuring voltage of 1 kV DC. The insulation resistance must be higher than 1 Mohm.

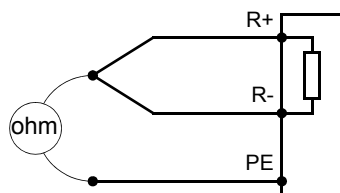

Power cable connection

Power cable connection diagram

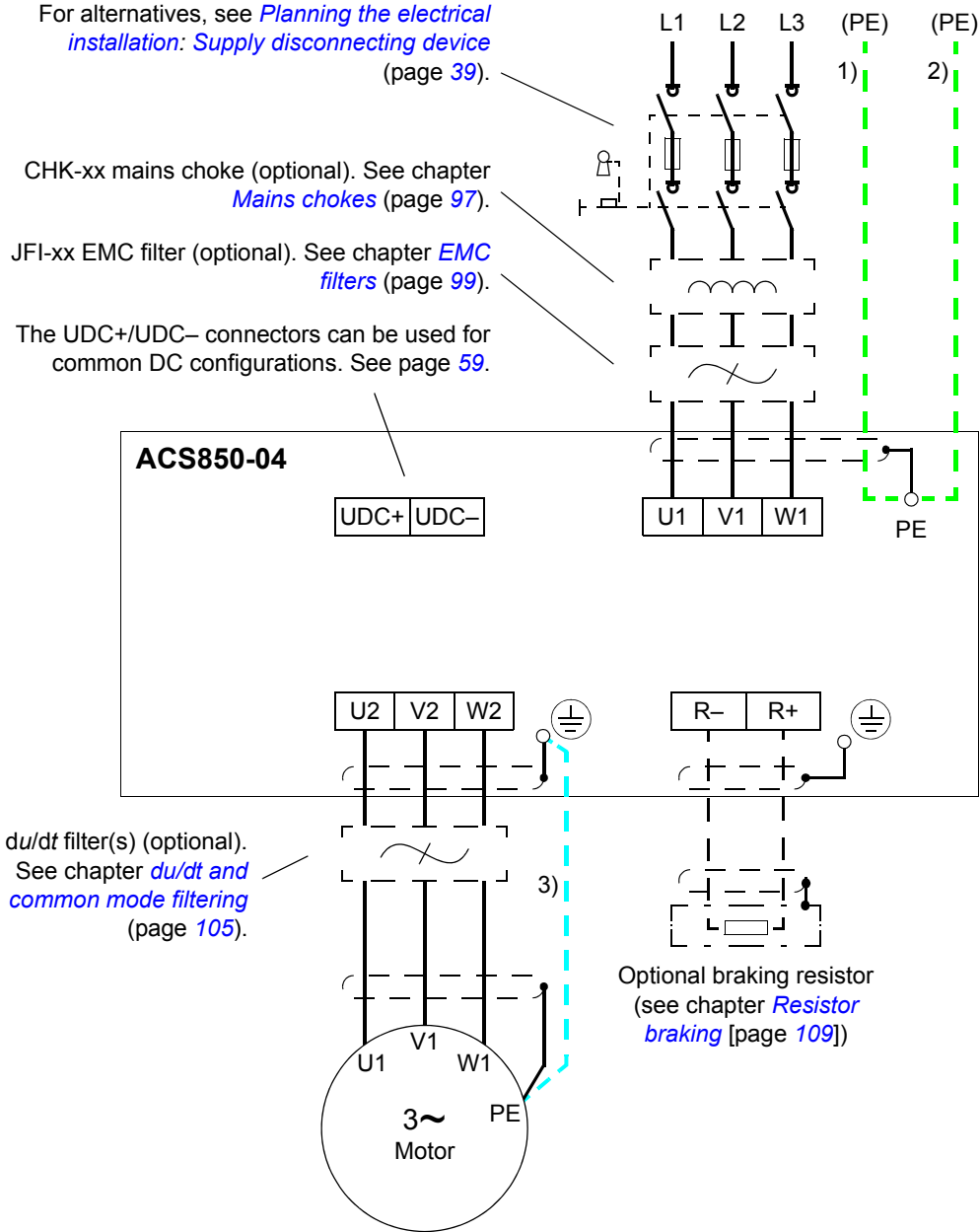

Notes:

- If shielded supply (input) cable is used, and the conductivity of the shield is not sufficient (see section [Selecting the power cables](#) on page 43), use a cable with a ground conductor (1) or a separate PE cable (2).
- For motor cabling, use a separate ground cable (3) if the conductivity of the cable shield is not sufficient (see section [Selecting the power cables](#) on page 43) and the cable has no symmetrical ground conductors.

Procedure

Cabling drawings with tightening torques for each frame size are presented on pages 56 to 58.

1. Frame sizes C and D only: Remove the two plastic connector covers at the top and bottom of the drive. Each cover is fastened with two screws.
2. On IT (ungrounded) systems and corner grounded TN systems, remove the following screws to disconnect the internal varistors and EMC filters:
 - VAR (frames A and B, located close to the supply terminals)
 - EMC, VAR1 and VAR2 (frames C and D, located on the front of the power unit).



WARNING! If a drive whose varistors/filters are not disconnected is installed on an IT system (an ungrounded power system or a high resistance grounded [over 30 ohms] power system), the system will be connected to earth potential through the varistors/filters of the drive. This may cause danger or damage the drive.

If a drive whose varistors/filters are not disconnected is installed on a corner grounded TN system, the drive will be damaged.

3. Fasten the two cable clamp plates included to the drive (see page 55), one at the top, one at the bottom. The clamp plates are identical. Using the cable clamp plates as shown below will provide better EMC compliance, as well as act as a strain relief for the power cables.
4. Strip the power cables so that the shields are bare at the cable clamps.
5. Twist the ends of the cable shield wires into pigtails.
6. Strip the ends of the phase conductors.
7. Connect the phase conductors of the supply cable to the U1, V1 and W1 terminals of the drive.
Connect the phase conductors of the motor cable to the U2, V2 and W2 terminals.
Connect the conductors of the resistor cable (if present) to the R+ and R- terminals.
With frame size C or D, attach the screw terminal lugs included to the conductors first. Crimp lugs can be used instead of the screw lugs.
8. Tighten the cable clamps onto the bare cable shields.
9. Crimp a cable lug onto each shield pigtail. Fasten the lugs to ground terminals.
Note: Try to work out a compromise between the length of the pigtail and the length of unshielded phase conductors as both should ideally be as short as possible.
10. Cover visible bare shield and pigtail with insulating tape.

11. With frame size C or D, cut suitable slots on the edges of the connector covers to accommodate the supply and motor cables. Refit the covers. (Tighten the screws to 3 N·m [25 lbf·in]).
12. Secure the cables outside the unit mechanically.
13. Ground the other end of the supply cable shield or PE conductor(s) at the distribution board. In case a mains choke and/or an EMC filter is installed, make sure the PE conductor is continuous from the distribution board to the drive.

Grounding the motor cable shield at the motor end

For minimum radio frequency interference, ground the cable shield 360 degrees at the lead-through of the motor terminal box

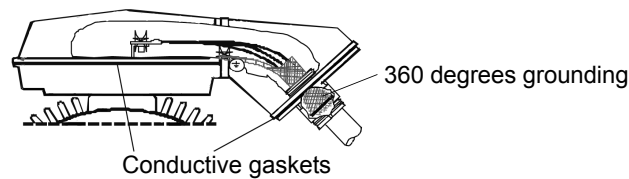

or ground the cable by twisting the shield so that the flattened shield is wider than 1/5 of its length.

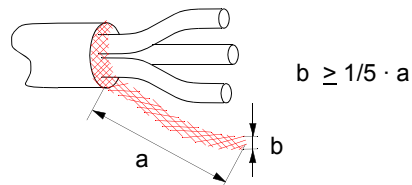

Installation of power cable clamp plates

Two identical power cable clamp plates are included with the drive. The picture below depicts a frame size A drive; the installation is similar with other frame sizes.

Note: Pay attention to supporting the cables adequately within the installation enclosure especially if not using the cable clamps.

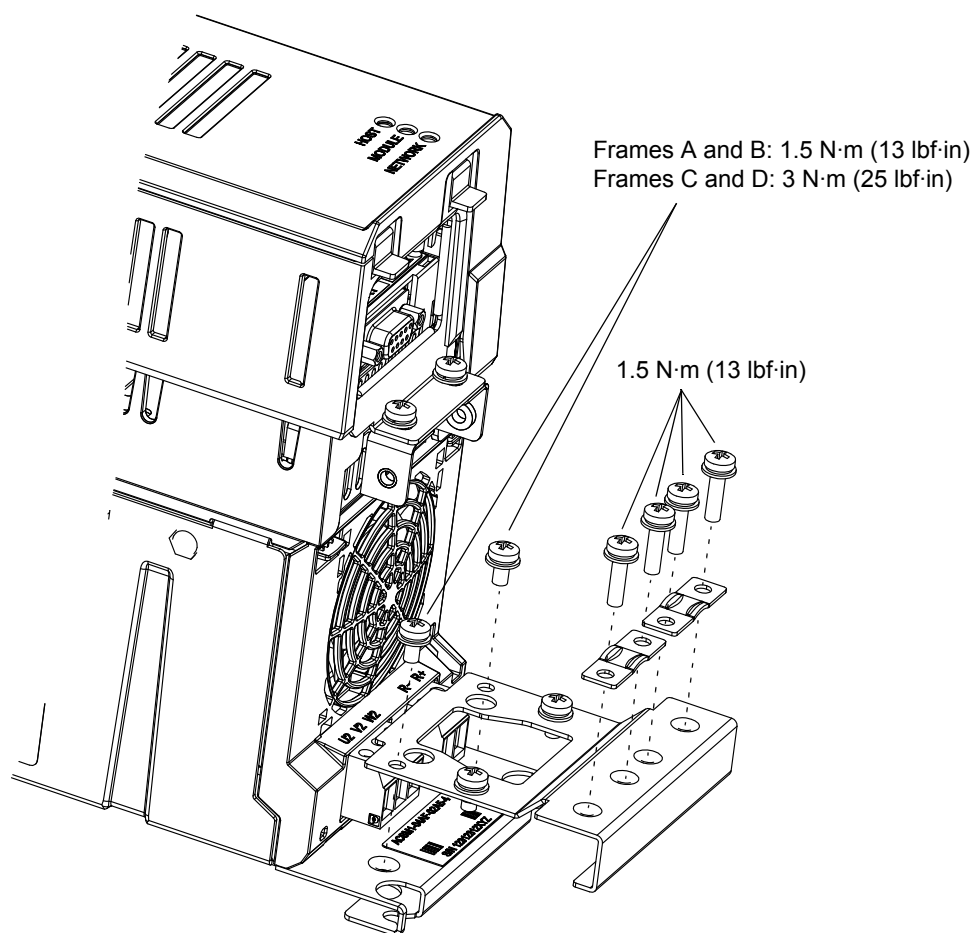

Power cable connection – frame size A

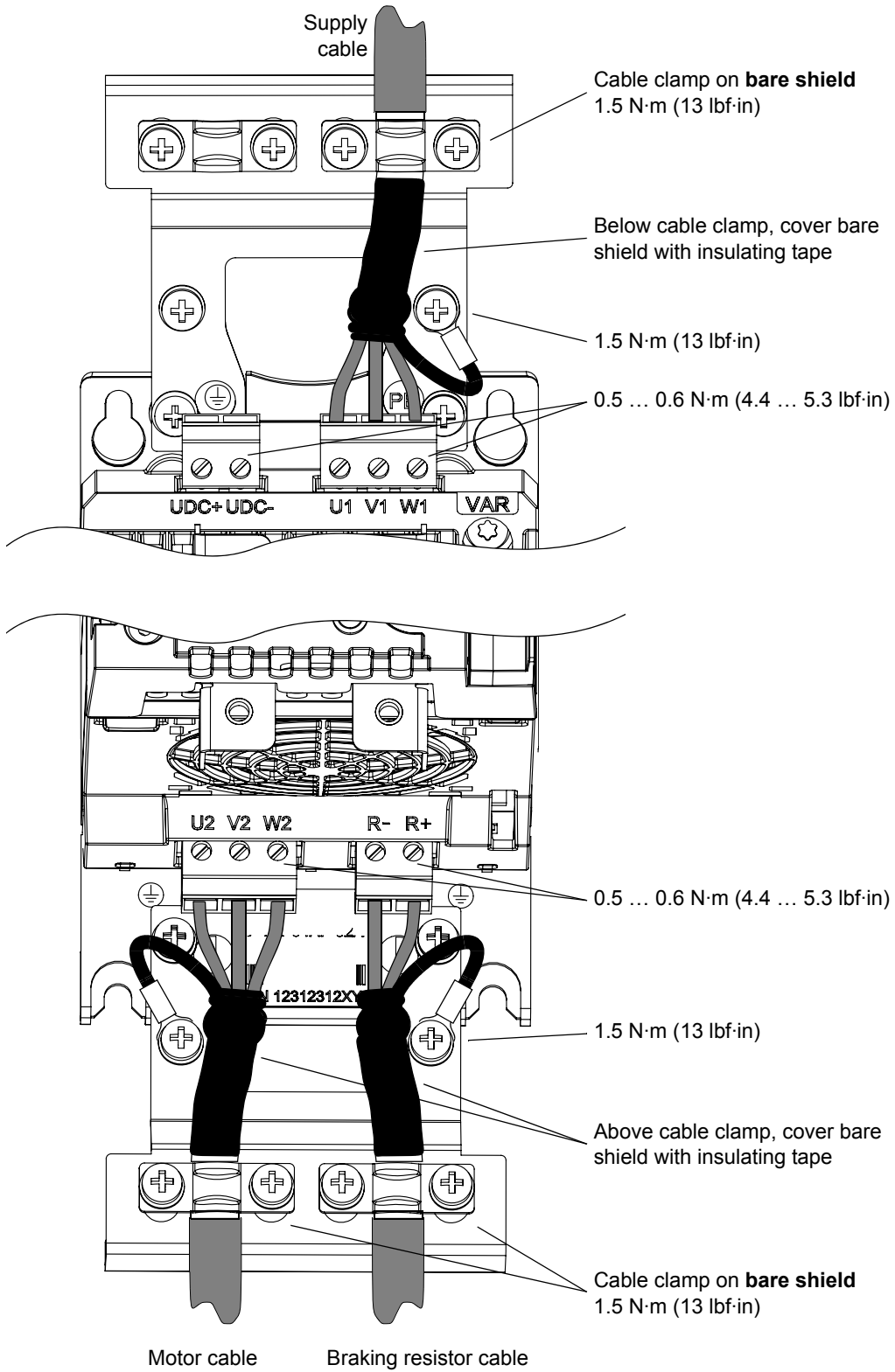

Power cable connection – frame size B

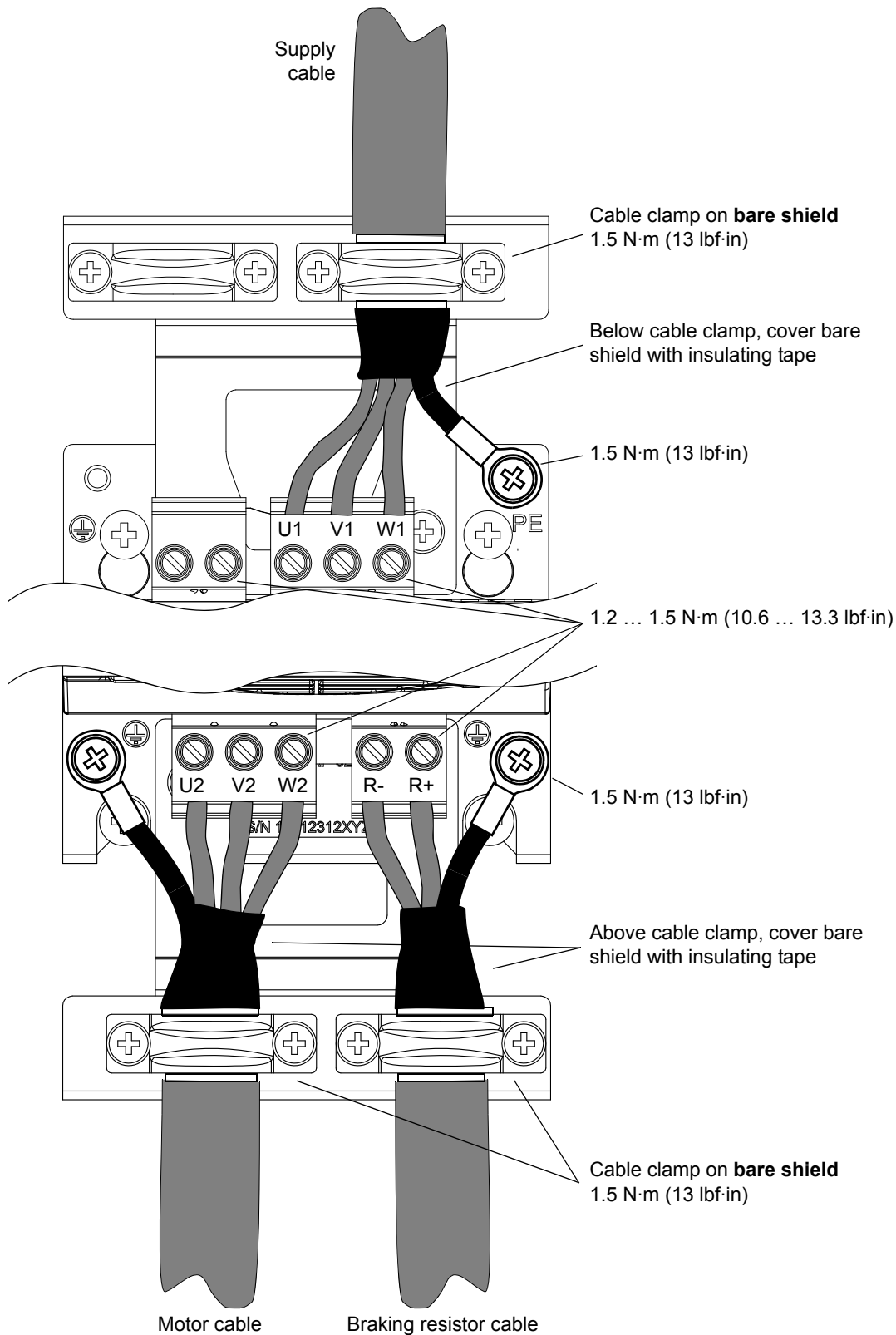

Power cable connection – frame sizes C and D (connector covers removed)

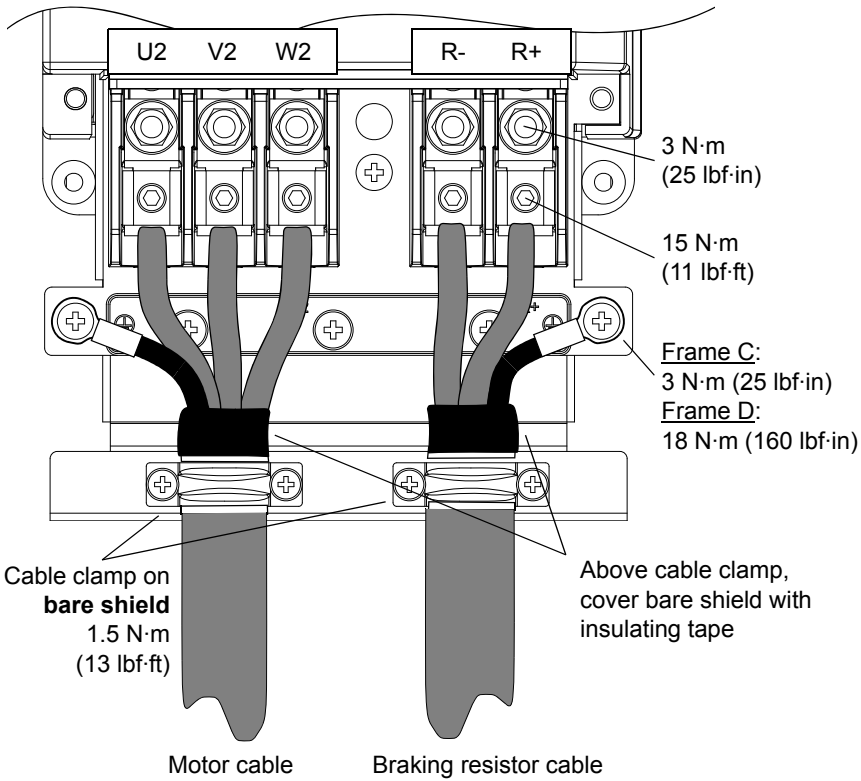
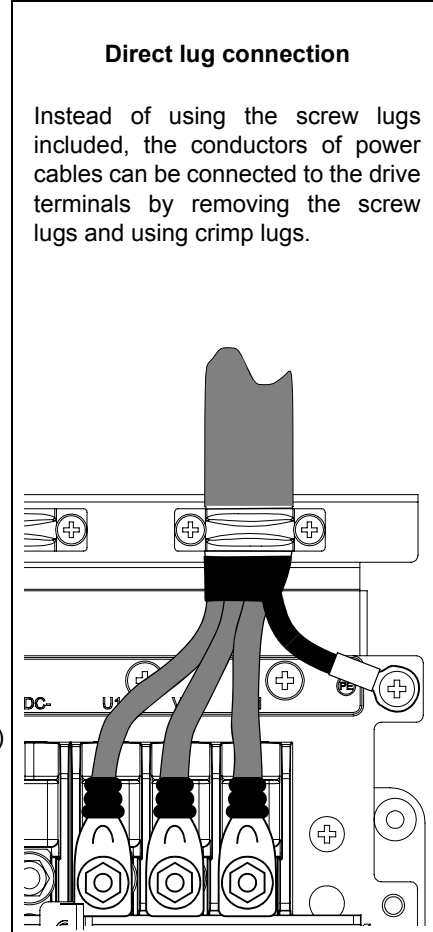
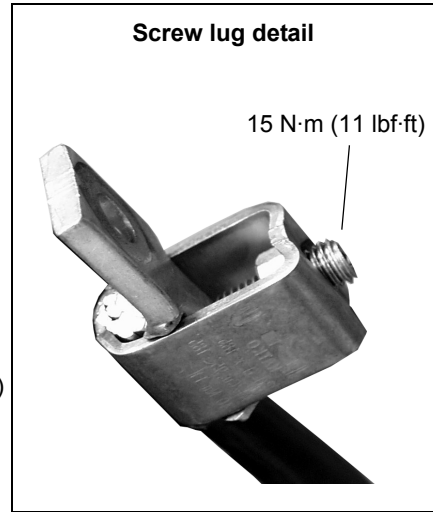
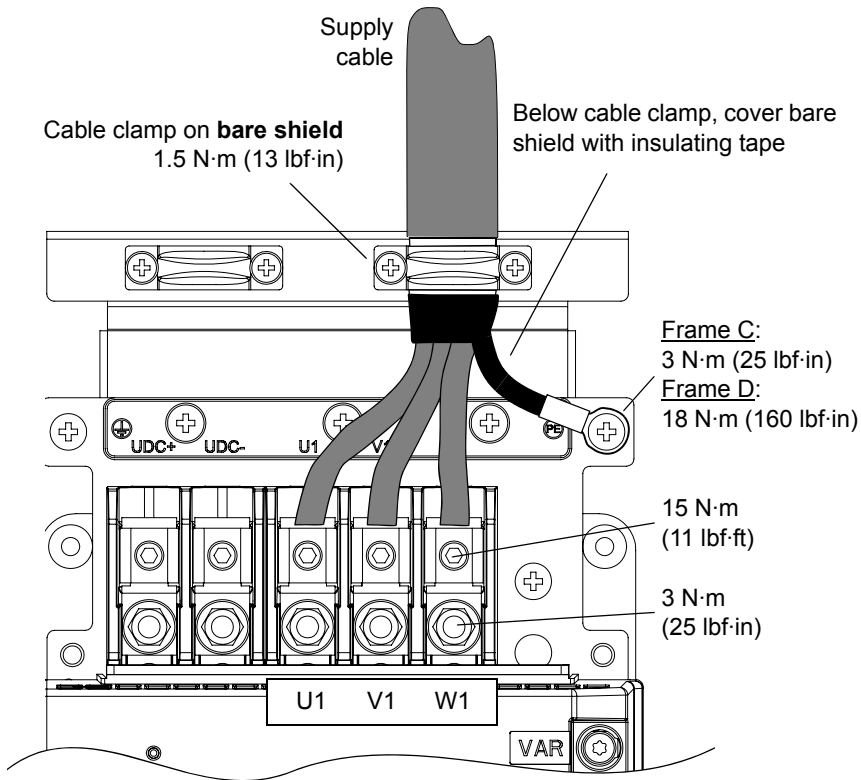

DC connection

The UDC+ and UDC– terminals are intended for common DC configurations of a number of ACS850 drives, allowing regenerative energy from one drive to be utilised by the other drives in motoring mode.

One or more drives are connected to the AC supply depending on the power requirement. In case two or more drives are connected to the AC supply, each AC connection must be equipped with a mains choke to ensure even current distribution between the rectifiers. The diagram below shows two configuration examples.

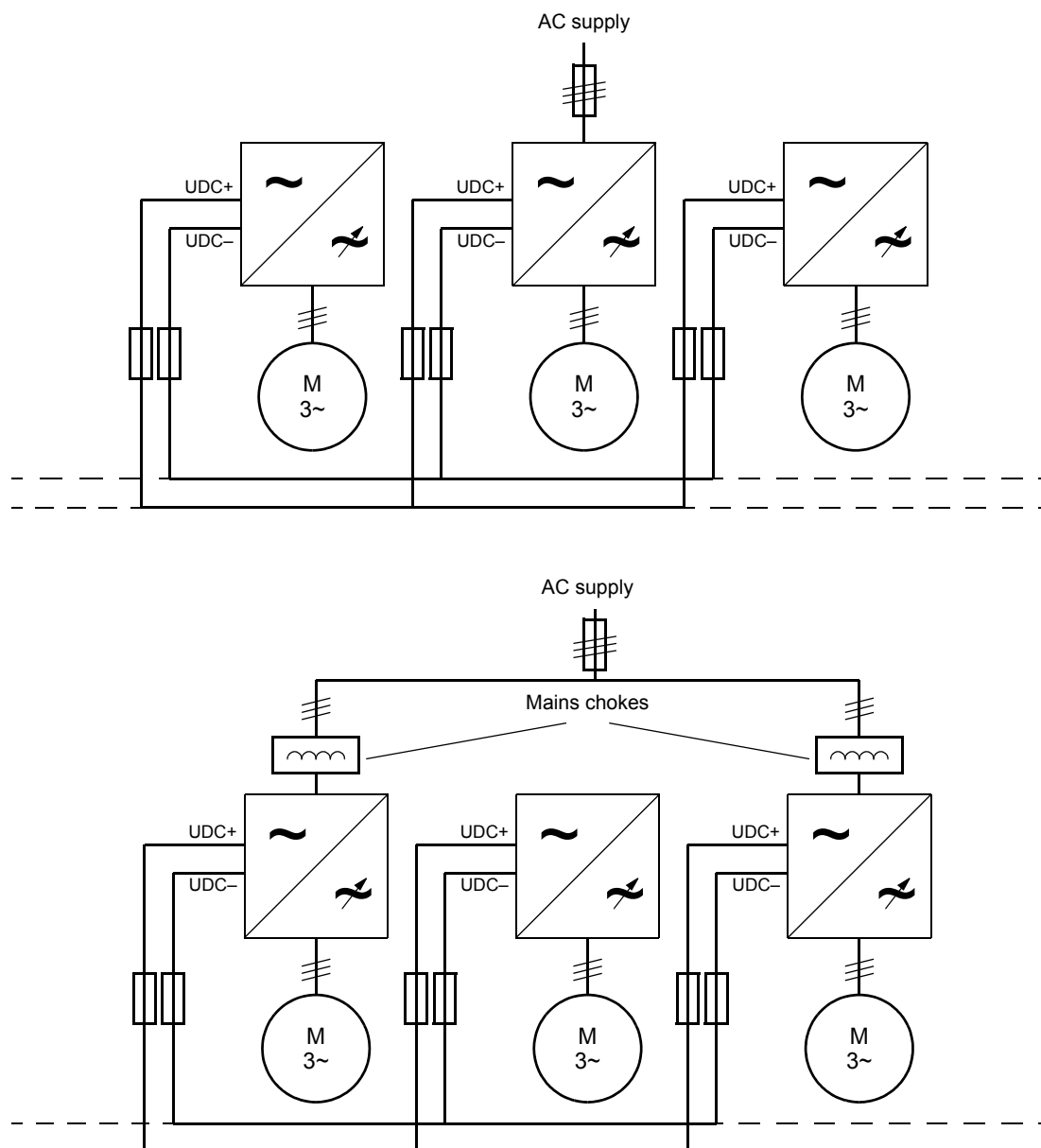

Each drive has an independent DC capacitor pre-charging circuit.

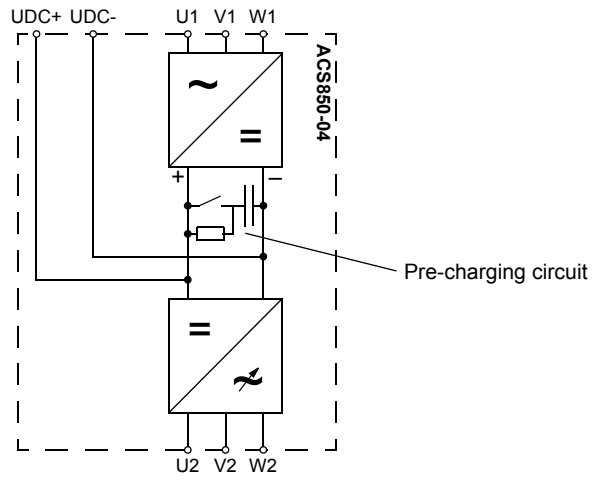

The ratings of the DC connection are given on page [85](#).

Installation of optional modules

Optional modules such as fieldbus adapters, I/O extensions and encoder interfaces ordered using option codes (see [Type designation](#) on page 25) are pre-installed at the factory. Instructions for installing additional modules into the slots on the JCU Control Unit (see page 24 for the available slots) are presented below.

Mechanical installation

- Remove the cover assembly from on the JCU Control Unit (refer to page 49).
- Remove the protective cover (if present) from the connector of the slot.
- Insert the module carefully into its position on the drive.
- Fasten the screw.

Note: Correct installation of the screw is essential for fulfilling the EMC requirements and for proper operation of the module.

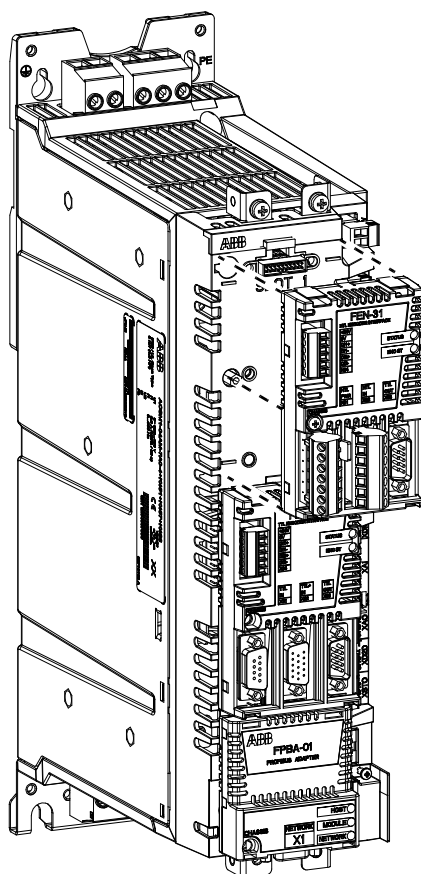

Electrical installation

See section [Grounding and routing the control cables](#) on page 62. See the appropriate option manual for specific installation and wiring instructions.

Connecting the control cables

Control connections to the JCU Control Unit

Notes:

[Default setting with ACS850 standard control program (Factory macro). See *Firmware Manual* for other macros.]

*Total maximum current: 200 mA

The wiring shown is for demonstrative purposes only. Further information of the usage of the connectors and jumpers are given in the text; see also chapter [Technical data](#).

Wire sizes and tightening torques:

XPOW, XRO1, XRO2, XRO3, XD24:
0.5 ... 2.5 mm² (24...12 AWG). Torque: 0.5 N·m (5 lbf·in)

XDI, XDIO, XAI, XAO, XD2D, XSTO:
0.5 ... 1.5 mm² (28...14 AWG). Torque: 0.3 N·m (3 lbf·in)

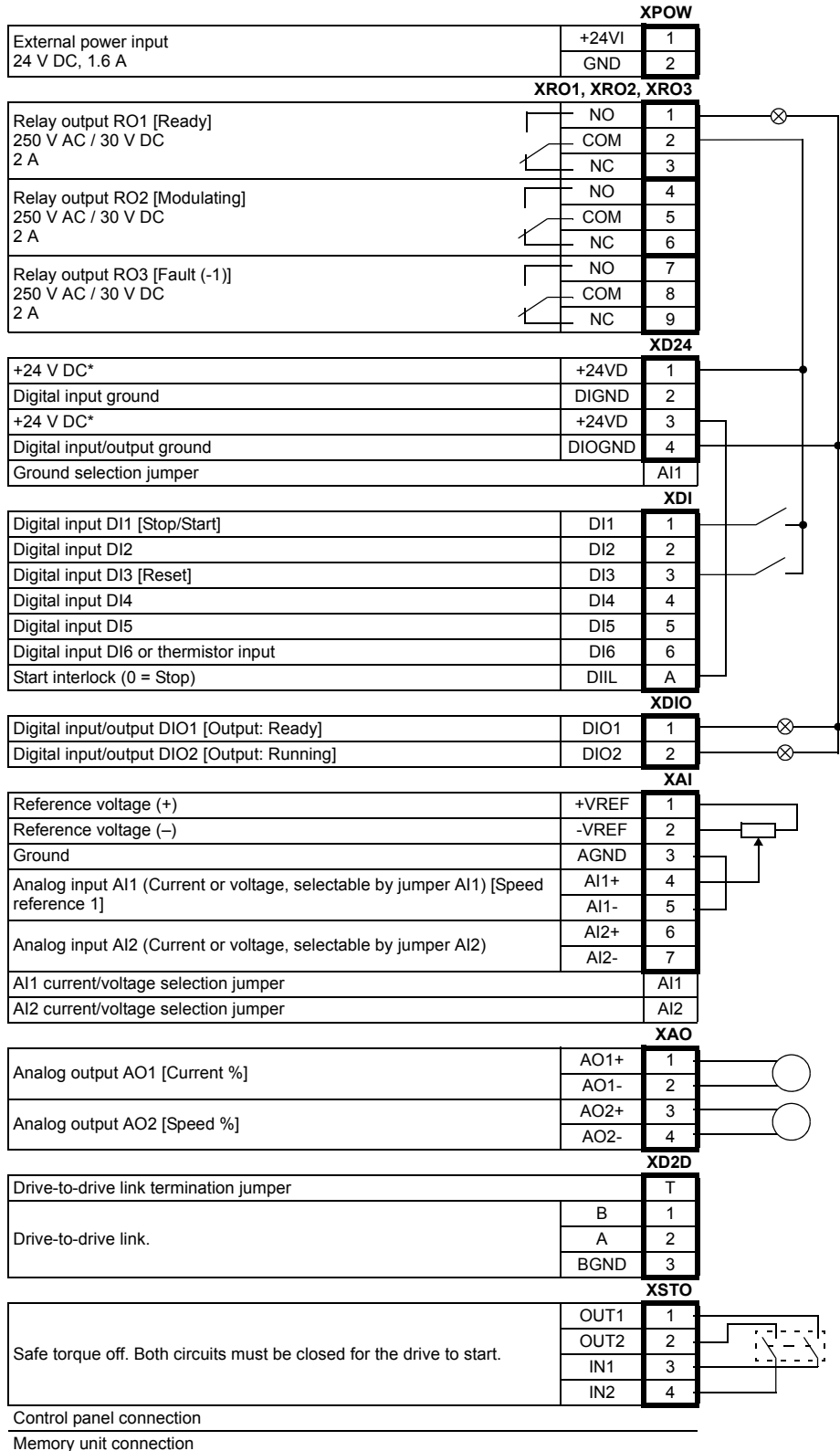
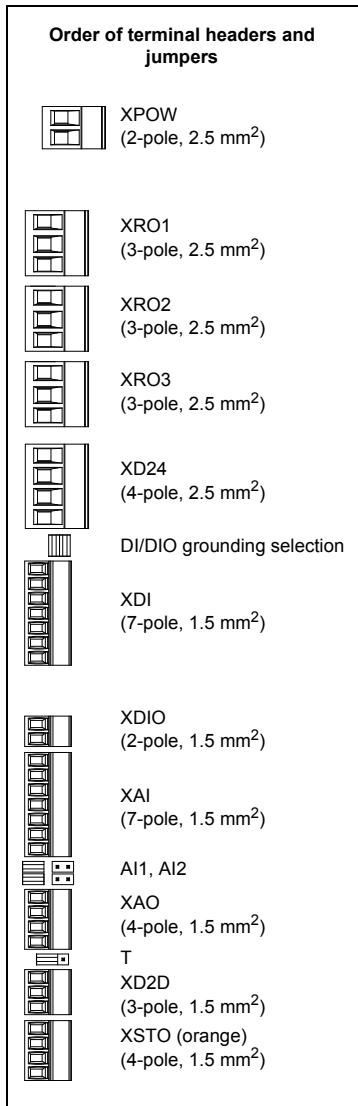

Jumpers

DI/DIO grounding selector (located between XD24 and XD1) – Determines whether the DIGND (ground for digital inputs DI1...DI5) floats, or if it is connected to DIOGND (ground for digital input DI6, and digital input/outputs DIO1 and DIO2). If DIGND floats, the common of DI1...DI5 (either GND or V_{CC}) should be connected to XD24:2. (See the JCU isolation and grounding diagram on page 88.)

DIGND floats

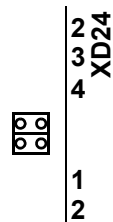

DIGND tied to DIOGND

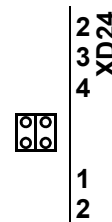

AI1 – Determines whether Analog input AI1 is used as a current or voltage input.

Current

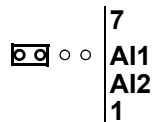

Voltage

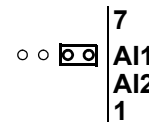

AI2 – Determines whether Analog input AI2 is used as a current or voltage input.

Current

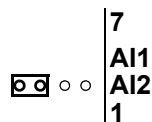

Voltage

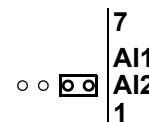

T – Drive-to-drive link termination. Must be set to the ON position when the drive is the last unit on the link.

Termination ON



Termination OFF

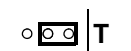

External power supply for the JCU Control Unit (XPOW)

External +24 V (minimum 1.6 A) power supply for the JCU Control Unit can be connected to terminal block XPOW. Using an external supply is recommended if

- the application requires fast start after connecting the drive to the main supply
- fieldbus communication is required when the input power supply is disconnected.

DI6 (XDI:6) as a thermistor input

1...3 PTC sensors can be connected to this input for motor temperature measurement.

One sensor

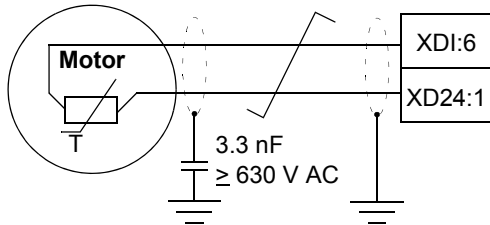

Three sensors

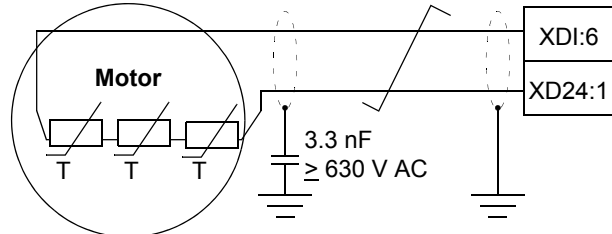

Notes:

- Do not connect both ends of the cable shields directly to ground. If a capacitor cannot be used at one end, leave that end of the shield unconnected.
- The connection of temperature sensors involves parameter adjustment. See the *Firmware Manual* of the drive.
- PTC (as well as KTY84) sensors can alternatively be connected to a FEN-xx encoder interface. See the *User's Manual* of the interface for wiring information.
- Pt100 sensors are not to be connected to the thermistor input. Instead, an analog input and an analog current output (located either on the JCU or on an I/O extension module) are used as shown below. The analog input must be set to voltage.

One Pt100 sensor

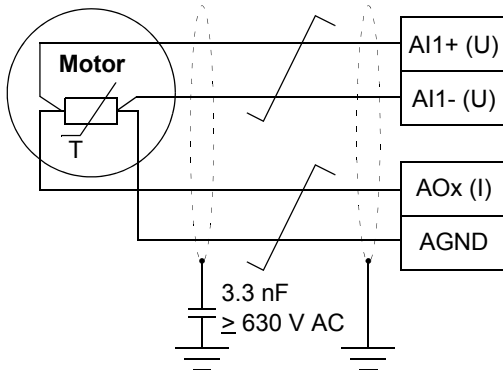

Three Pt100 sensors

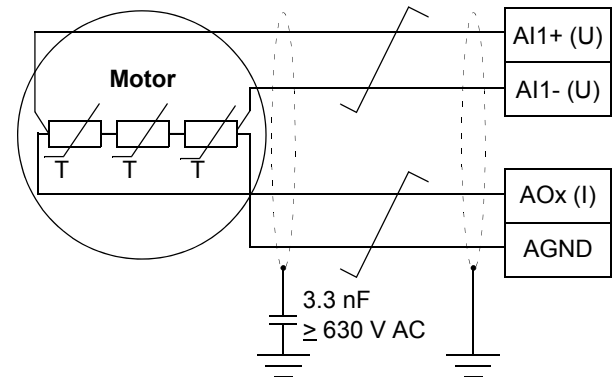

WARNING! As the inputs pictured above are not insulated according to IEC 60664, the connection of the motor temperature sensor requires double or reinforced insulation between motor live parts and the sensor. If the assembly does not fulfil the requirement,

- all I/O terminals must be protected against contact and must not be connected to other equipment

or

- the temperature sensor must be isolated from the I/O terminals.

Drive-to-drive link (XD2D)

The drive-to-drive link is a daisy-chained RS-485 transmission line that allows basic master/follower communication with one master drive and multiple followers.

Termination activation jumper T (see section [Jumpers](#) above) next to this terminal block must be set to the ON position on the drives at the ends of the drive-to-drive link. On intermediate drives, the jumper must be set to the OFF position.

Shielded twisted-pair cable (~100 ohm, e.g. PROFIBUS-compatible cable) must be used for the wiring. For best immunity, high quality cable is recommended. The cable should be kept as short as possible; the maximum length of the link is 100 metres (328 ft). Unnecessary loops and running the cable near power cables (such as motor cables) must be avoided. The cable shields are to be grounded to the control cable clamp plate on the drive as shown on page [66](#).

The following diagram shows the wiring of the drive-to-drive link.

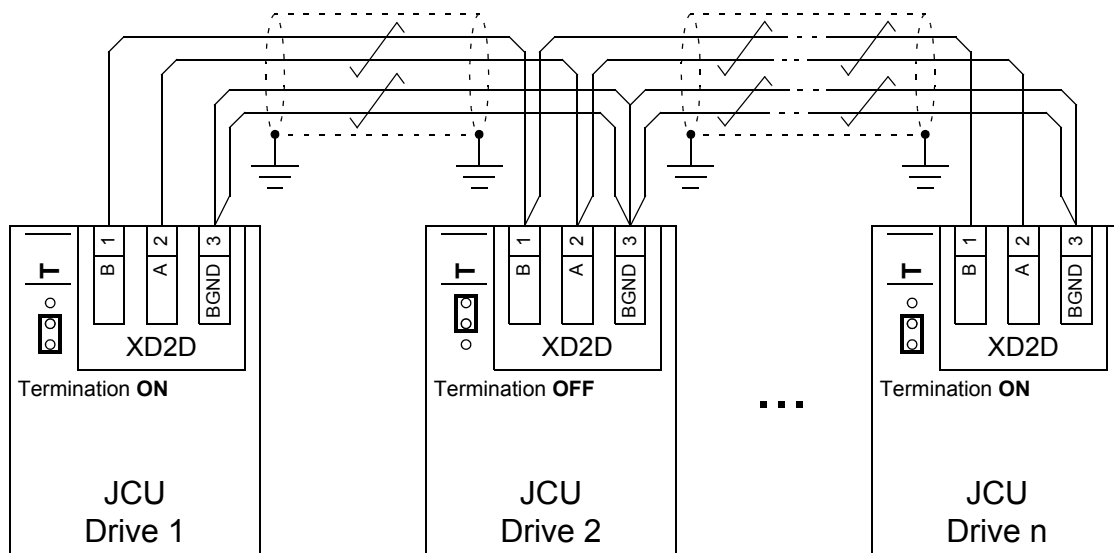

Note: The drive-to-drive link can be used only if the embedded fieldbus interface is disabled. For more information on the embedded fieldbus interface, see the *Firmware Manual*.

Safe torque off (XSTO)

For the drive to start, both connections (OUT1 to IN1, and OUT2 to IN2) must be closed. This is implemented by means of a safety switch and related wiring. See page [42](#).

By default, the terminal block has jumpers to close the circuit. Remove the jumpers before connecting an external Safe torque off circuitry to the drive.

More information is available in *Safe torque off function for ACSM1, ACS850 and ACQ810 drives application guide* (3AFE68929814 [English]). For related parameter settings, see the appropriate *Firmware Manual*.

Grounding and routing the control cables

The shields of all control cables connected to the JCU Control Unit must be grounded at the control cable clamp plate. Use four M4 screws to fasten the plate as shown below left (two of the screws are also used to hold the cover mounting bracket). The plate can be fitted either at the top or bottom of the drive.

Before connecting the wires, run the cables through the cover mounting bracket as shown in the drawing below.

The shields should be continuous as close to the terminals of the JCU as possible. Only remove the outer jacket of the cable at the cable clamp so that the clamp presses on the bare shield. At the terminal block, use shrink tubing or insulating tape to contain any stray strands. The shield (especially in case of multiple shields) can also be terminated with a lug and fastened with a screw at the clamp plate. Leave the other end of the shield unconnected or ground it indirectly via a few nanofarads high-frequency capacitor (e.g. 3.3 nF / 630 V). The shield can also be grounded directly at both ends if they are *in the same ground line* with no significant voltage drop between the end points.

Keep any signal wire pairs twisted as close to the terminals as possible. Twisting the wire with its return wire reduces disturbances caused by inductive coupling.

Re-install the cover assembly according to the instructions on page [49](#).

Mounting the clamp plate

Routing the control cables

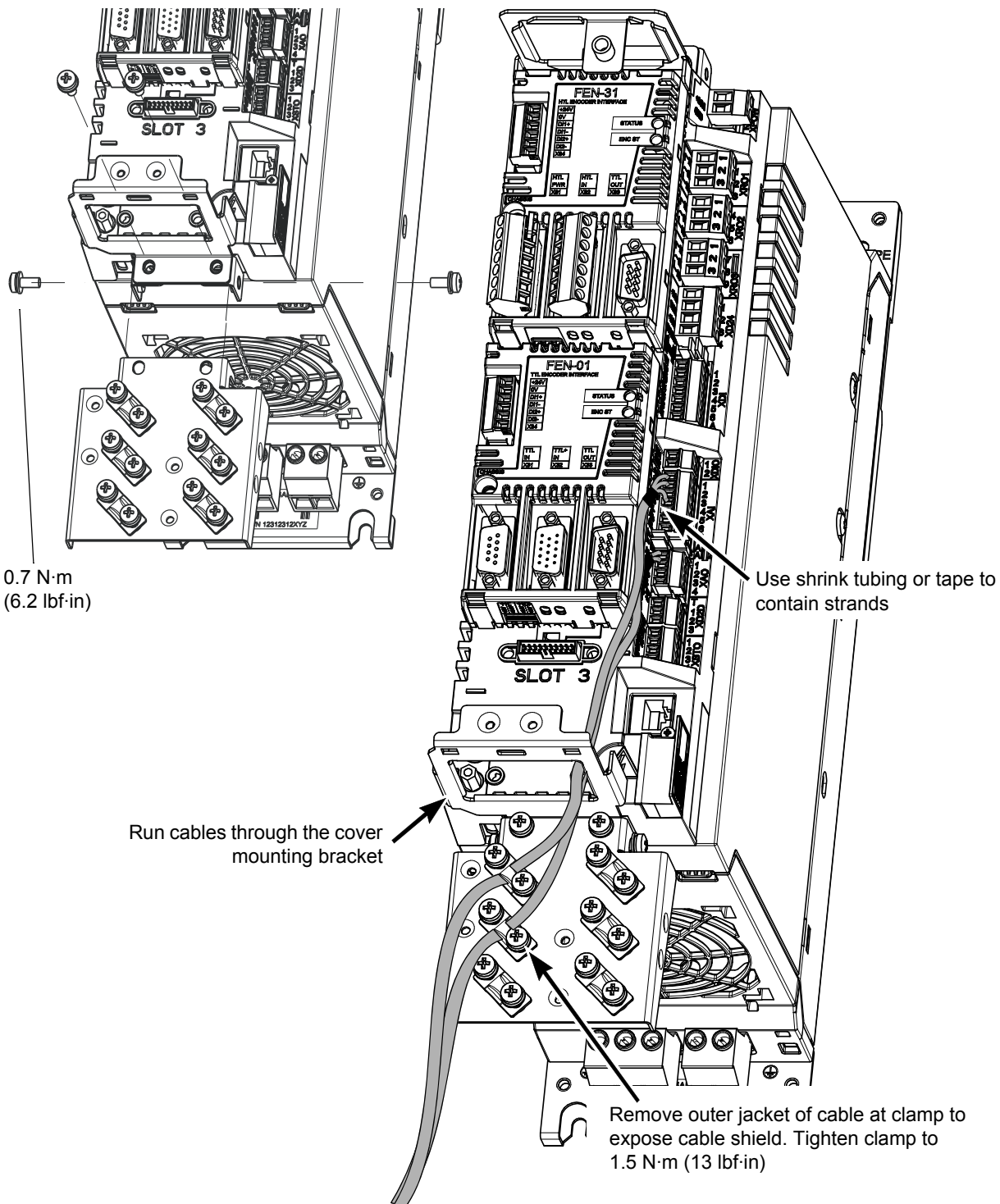

0.7 N·m
(6.2 lbf-in)

Run cables through the cover mounting bracket

Use shrink tubing or tape to contain strands

Remove outer jacket of cable at clamp to expose cable shield. Tighten clamp to 1.5 N·m (13 lbf-in)

Installation checklist

efesotomasyon.com

Checklist

Check the mechanical and electrical installation of the drive before start-up. Go through the checklist below together with another person. Read the [Safety instructions](#) on the first pages of this manual before you work on the unit.

Check
MECHANICAL INSTALLATION
<input type="checkbox"/> The ambient operating conditions are allowable. (See Mechanical installation, Technical data: Ratings, Ambient conditions .)
<input type="checkbox"/> The unit is fastened properly to the cabinet. (See Planning the cabinet assembly and Mechanical installation .)
<input type="checkbox"/> The cooling air will flow freely.
<input type="checkbox"/> The motor and the driven equipment are ready for start. (See Planning the electrical installation, Technical data: Motor connection .)
ELECTRICAL INSTALLATION (See Planning the electrical installation, Electrical installation .)
<input type="checkbox"/> The VAR (frames A and B) and EMC/VAR1/VAR2 (frames C and D) screws are removed if the drive is connected to an IT (ungrounded) supply network.
<input type="checkbox"/> The capacitors are reformed if stored over one year (ask local ABB representative for more information).
<input type="checkbox"/> The drive is grounded properly.
<input type="checkbox"/> The supply (input power) voltage matches the drive nominal input voltage.
<input type="checkbox"/> The supply (input power) is connected to U1/V1/W1 (UDC+/UDC- in case of a DC supply) and the terminals are tightened to specified torque.
<input type="checkbox"/> Appropriate supply (input power) fuses and disconnecter are installed.
<input type="checkbox"/> The motor is connected to U2/V2/W2, and the terminals are tightened to specified torque.
<input type="checkbox"/> The braking resistor (if present) is connected to R+/R-, and the terminals are tightened to specified torque.
<input type="checkbox"/> The motor cable (and braking resistor cable, if present) is routed away from other cables.
<input type="checkbox"/> There are no power factor compensation capacitors in the motor cable.
<input type="checkbox"/> The external control connections to the JCU Control Unit are OK.
<input type="checkbox"/> There are no tools, foreign objects or dust from drilling inside the drive.

Check

- The supply (input power) voltage cannot be applied to the output of the drive through a bypass connection.
- Motor connection box and other covers are in place.

Maintenance

What this chapter contains

This chapter contains preventive maintenance instructions.

Safety



WARNING! Read the *Safety instructions* on the first pages of this manual before performing any maintenance on the equipment. Ignoring the safety instructions can cause injury or death.

Maintenance intervals

The table below lists the routine maintenance intervals recommended by ABB. Consult a local ABB Service representative for more details. On the Internet, go to <http://www.abb.com/drives>, select *Drive Services*, and *Maintenance and Field Services*.

Interval	Maintenance	Instruction
Every year of storage	DC capacitor reforming	See <i>Reforming the capacitors</i> on page 75.
Every 6 to 12 months depending on the dustiness of the environment	Heatsink temperature check and cleaning	See <i>Heatsink</i> on page 72.
Every year	Inspection of tightness of power connections	See pages 56-58.
	Visual inspection of cooling fan	See <i>Cooling fan</i> on page 73.
Every 3 years if the ambient temperature is higher than 40 °C (104 °F). Otherwise, every 6 years .	Cooling fan replacement	See <i>Cooling fan</i> on page 73.
Every 6 years if the ambient temperature is higher than 40 °C (104 °F) or if the drive is subjected to cyclic heavy load or continuous nominal load. Otherwise, every 9 years .	DC capacitor replacement	Contact your local ABB Service representative.
Every 10 years	Control panel battery replacement.	The battery is housed on the rear of the control panel. Replace with a new CR 2032 battery.

Heatsink

The heatsink fins pick up dust from the cooling air. The drive runs into overtemperature warnings and faults if the heatsink is not clean. In a normal environment, the heatsink should be checked annually, in a dusty environment more often.

Clean the heatsink as follows (when necessary):

1. Remove the cooling fan (see section [Cooling fan](#)).
2. Blow clean compressed air (not humid) from bottom to top and simultaneously use a vacuum cleaner at the air outlet to trap the dust. **Note:** If there is a risk of the dust entering adjoining equipment, perform the cleaning in another room.
3. Refit the cooling fan.

Cooling fan

The actual lifespan of the cooling fan depends on the drive usage and ambient temperature. Fan failure can be predicted by the increasing noise from fan bearings and the gradual rise in the heatsink temperature in spite of heatsink cleaning. If the drive is operated in a critical part of a process, fan replacement is recommended once these symptoms start appearing. Replacement fans are available from ABB. Do not use other than ABB-specified spare parts.

Fan replacement (Frames A and B)

Detach the power cable clamp plate and terminal blocks. Release the retaining clips (arrowed) carefully using a screwdriver. Pull the fan holder out. Disconnect the fan cable. Carefully bend the clips on the fan holder to free the fan.

Install the new fan in reverse order.

Note: The airflow direction is bottom-to-top. Install the fan so that the airflow arrow points up.

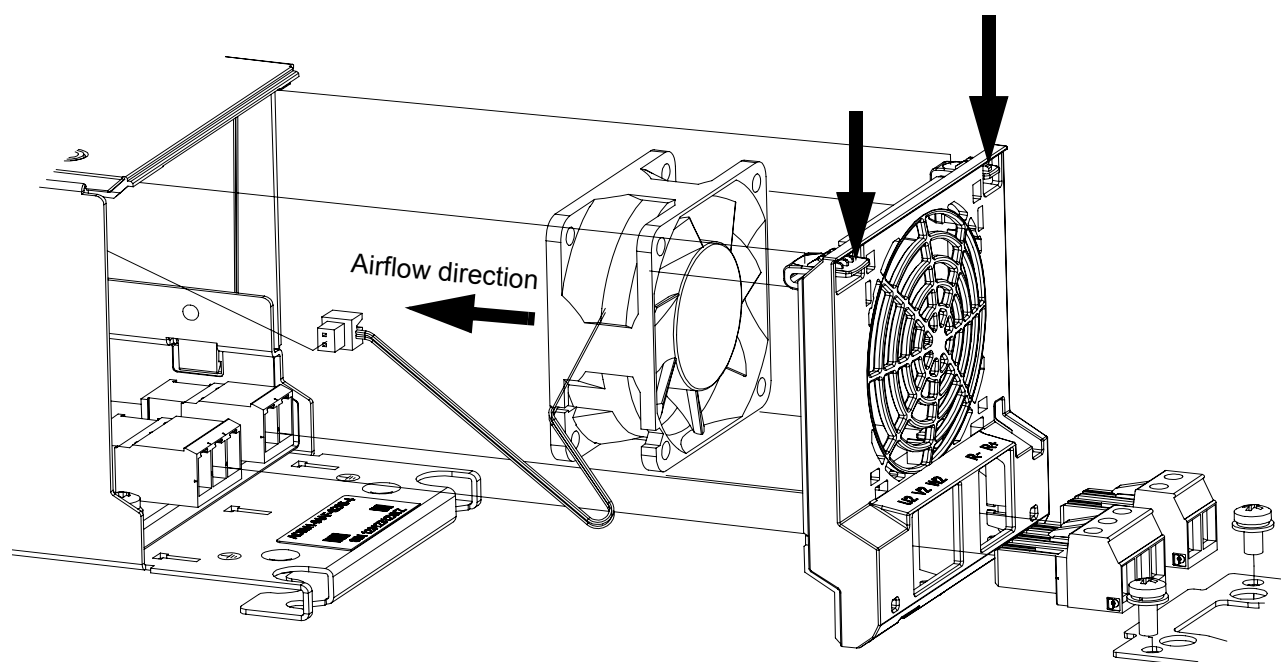

Fan replacement (Frames C and D)

To remove the fan, release the retaining clip (arrowed) carefully using a screwdriver. Pull the fan holder out. Disconnect the fan cable. Carefully bend the clips on the fan holder to free the fan.

Install the new fan in reverse order.

Note: The airflow direction is bottom-to-top. Install the fan so that the airflow arrow points up.

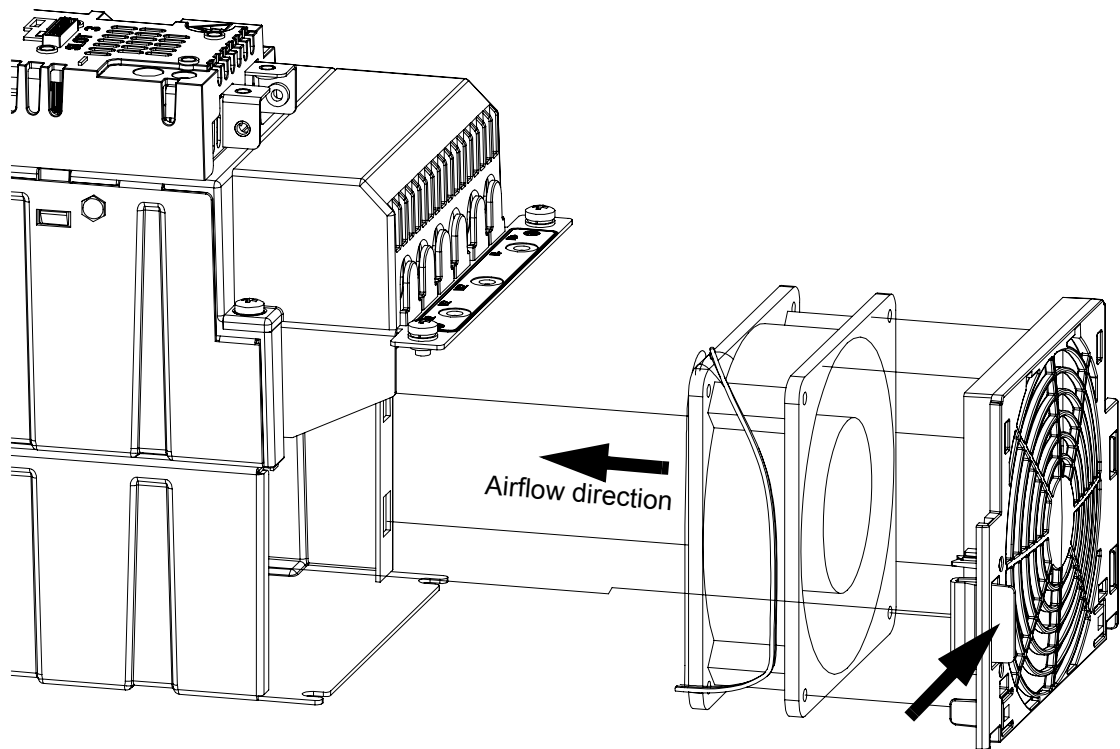

Reforming the capacitors

The capacitors must be reformed if the drive has been stored for a year or more. See page 35 for information on finding out the manufacturing date. For information on reforming the capacitors, contact your local ABB representative.

Other maintenance actions

Transferring the memory unit to a new drive module

When a drive module is replaced, the parameter settings can be retained by transferring the memory unit from the defective drive module to the new module.



WARNING! Do not remove or insert a memory unit when the drive module is powered.

After power-up, the drive will scan the memory unit. If a different application program or different parameter settings are detected, they are copied to the drive. This takes about 10 to 30 seconds; the drive will not respond while copying is in progress.

Technical data efesotomasyon.com

What this chapter contains

This chapter contains the technical specifications of the drive, e.g. the ratings, sizes and technical requirements, and provisions for fulfilling the requirements for CE and other markings.

Ratings

Nominal ratings with 230 V AC supply

Drive type ACS850-04...	Frame size	Input ratings		Output ratings									
				Nominal		No-overload use		Light-overload use			Heavy-duty use		
		I_{1N} A	$*I_{1N}$ A	I_{2N} A	I_{Max} A	P_N		I_{Ld} A	P_{Ld} kW	P_{Ld} HP	I_{Hd} A	P_{Hd} kW	P_{Hd} HP
-03A0-2	A	2.1	3.5	3.0	4.4	0.37	0.5	2.8	0.37	0.5	2.5	0.37	0.5
-03A6-2	A	2.9	5.2	3.6	5.3	0.55	0.75	3.4	0.55	0.75	3.0	0.37	0.5
-04A8-2	A	3.7	6.3	4.8	7.0	0.75	1	4.5	0.75	1	4.0	0.55	0.75
-06A0-2	A	5.2	8.9	6.0	8.8	1.1	1.5	5.5	1.1	1.5	5.0	0.75	1
-08A0-2	A	6.3	10.7	8.0	10.5	1.5	2	7.6	1.5	2	6.0	1.1	1.5
-010A-2	B	8.3	13	10.5	13.5	2.2	3	9.7	2.2	3	9.0	1.5	2
-014A-2	B	11	17	14	16.5	3	3	13.0	3	3	11.0	2.2	3
-018A-2	B	15	21	18	21	4	5	16.8	4	5	14.0	3	3
-025A-2	C	19	–	25	33	5.5	7.5	23	5.5	7.5	19.0	4	5
-030A-2	C	26	–	30	36	7.5	10	28	7.5	10	24	5.5	7.5
-035A-2	C	30	–	35	44	7.5	10	32	7.5	10	29	7.5	10
-044A-2	C	35	–	44	53	11	15	41	11	15	35	7.5	10
-050A-2	C	42	–	50	66	11	15	46	11	15	44	11	15
-061A-2	D	54	–	61	78	15	20	57	15	20	52	11	15
-078A-2	D	64	–	78	100	18.5	25	74	18.5	25	69	15	20
-094A-2	D	81	–	94	124	22	30	90	22	30	75	18.5	25

581898

Nominal ratings with 400 V AC supply

Drive type ACS850-04...	Frame size	Input ratings		Output ratings						
				Nominal		No-overload use	Light-overload use		Heavy-duty use	
		I_{1N} A	$*I_{1N}$ A	I_{2N} A	I_{Max} A	P_N kW	I_{Ld} A	P_{Ld} kW	I_{Hd} A	P_{Hd} kW
-03A0-5	A	2.3	3.8	3.0	4.4	1.1	2.8	1.1	2.5	0.75
-03A6-5	A	3.1	5.6	3.6	5.3	1.5	3.4	1.5	3.0	1.1
-04A8-5	A	4.0	6.8	4.8	7.0	2.2	4.5	1.5	4.0	1.5
-06A0-5	A	5.5	9.4	6.0	8.8	2.2	5.5	2.2	5.0	2.2
-08A0-5	A	6.6	11.2	8.0	10.5	3.0	7.6	3.0	6.0	2.2
-010A-5	B	8.7	13	10.5	13.5	4.0	9.7	4.0	9.0	4.0
-014A-5	B	12	18	14	16.5	5.5	13.0	5.5	11.0	5.5
-018A-5	B	16	23	18	21	7.5	16.8	7.5	14.0	7.5
-025A-5	C	20	–	25	33	11.0	23	11	19.0	7.5
-030A-5	C	26	–	30	36	15.0	28	15	24	11.0
-035A-5	C	30	–	35	44	18.5	32	15	29	15.0
-044A-5	C	36	–	44	53	22	41	22	35	18.5
-050A-5	C	42	–	50	66	22	46	22	44	22
-061A-5	D	55	–	61	78	30	57	30	52	22
-078A-5	D	65	–	78	104	37	74	37	66	37
-094A-5	D	82	–	94	124	45	90	45	75	37

581898

Nominal ratings with 460 V AC supply

Drive type ACS850-04...	Frame size	Input ratings		Output ratings						
				Nominal		No-overload use	Light-overload use		Heavy-duty use	
		I_{1N} A	$*I_{1N}$ A	I_{2N} A	I_{Max} A	P_N HP	I_{Ld} A	P_{Ld} HP	I_{Hd} A	P_{Hd} HP
-03A0-5	A	2.3	3.8	3.0	4.4	1.5	2.8	1.0	2.5	1.0
-03A6-5	A	3.1	5.6	3.6	5.3	2.0	3.4	2.0	3.0	1.5
-04A8-5	A	4.0	6.8	4.8	7.0	3.0	4.5	2.0	4.0	2.0
-06A0-5	A	5.5	9.4	6.0	8.8	3.0	5.5	3.0	5.0	3.0
-08A0-5	A	6.6	11.2	8.0	10.5	5.0	7.6	5.0	6.0	3.0
-010A-5	B	8.7	13	10.5	13.5	5.0	9.7	5.0	9.0	5.0
-014A-5	B	12	18	14	16.5	7.5	13.0	7.5	11.0	7.5
-018A-5	B	16	23	18	21	10	16.8	10	14.0	10
-025A-5	C	20	–	25	33	15	23	15	19.0	10
-030A-5	C	26	–	30	36	20	28	20	24	15
-035A-5	C	30	–	35	44	25	32	20	29	20
-044A-5	C	36	–	44	53	30	41	30	35	25
-050A-5	C	42	–	50	66	30	46	30	44	30
-061A-5	D	55	–	61	78	40	57	40	52	40
-078A-5	D	65	–	78	104	50	74	50	66	50
-094A-5	D	82	–	94	124	60	90	60	75	50

581898

Nominal ratings with 500 V AC supply

Drive type ACS850-04...	Frame size	Input ratings		Output ratings						
				Nominal		No-overload use	Light-overload use		Heavy-duty use	
		I_{1N} A	* I_{1N} A	I_{2N} A	I_{Max} A	P_N kW	I_{Ld} A	P_{Ld} kW	I_{Hd} A	P_{Hd} kW
-03A0-5	A	2.3	3.8	3.0	4.4	1.5	2.8	1.1	2.5	1.1
-03A6-5	A	3.1	5.6	3.6	5.3	1.5	3.4	1.5	3.0	1.5
-04A8-5	A	4.0	6.8	4.8	7.0	2.2	4.5	2.2	4.0	2.2
-06A0-5	A	5.5	9.4	6.0	8.8	3.0	5.5	3.0	5.0	2.2
-08A0-5	A	6.6	11.2	8.0	10.5	4.0	7.6	4.0	6.0	3.0
-010A-5	B	8.7	13	10.5	13.5	5.5	9.7	5.5	9.0	4.0
-014A-5	B	12	18	14	16.5	7.5	13.0	7.5	11.0	5.5
-018A-5	B	16	23	18	21	11.0	16.8	7.5	14.0	7.5
-025A-5	C	20	–	25	33	15.0	23	11.0	19.0	11.0
-030A-5	C	26	–	30	36	18.5	28	15.0	24	15.0
-035A-5	C	30	–	35	44	22	32	18.5	29	18.5
-044A-5	C	36	–	44	53	30	41	22	35	22
-050A-5	C	42	–	50	66	30	46	30	44	30
-061A-5	D	55	–	61	78	37	57	37	52	30
-078A-5	D	65	–	78	104	45	74	45	66	45
-094A-5	D	82	–	94	124	55	90	55	75	45

581898

Symbols

I_{1N}	Nominal input current (rms) at 40 °C (104 °F). *Without mains choke.
I_{2N}	Nominal output current.
I_{Max}	Maximum output current. Available for at least 10 seconds at start, otherwise as long as allowed by drive temperature.
P_N	Typical motor power for no-overload use.
I_{Ld}	Continuous rms output current. 10% overload is allowed for 1 minute every 5 minutes.
P_{Ld}	Typical motor power for light-overload use.
I_{Hd}	Continuous rms output current. 50% overload is allowed for 1 minute every 5 minutes.
P_{Hd}	Typical motor power for heavy-duty use.

Note: To achieve the rated motor power given in the table, the rated current of the drive must be higher than or equal to the rated motor current.

The DriveSize dimensioning tool available from ABB is recommended for selecting the drive, motor and gear combination.

The maximum allowed motor shaft power is limited to $1.5 \cdot P_{Hd}$, $1.1 \cdot P_N$ or $P_{cont,max}$ (whichever value is the greatest). If the limit is exceeded, motor torque and current are automatically restricted. The function protects the input bridge of the drive against overload.

Derating

The continuous output currents stated above must be derated if any of the following conditions apply:

- the ambient temperature exceeds +40 °C (+104°F)
- the drive is installed higher than 1000 m above sea level
- the parameter-adjustable motor noise level is set as low.

Note: The final derating factor is a multiplication of all applicable derating factors.

Ambient temperature derating

In the temperature range +40...55 °C (+104...131 °F), the rated output current is derated by 1% for every added 1 °C (1.8 °F) as follows:

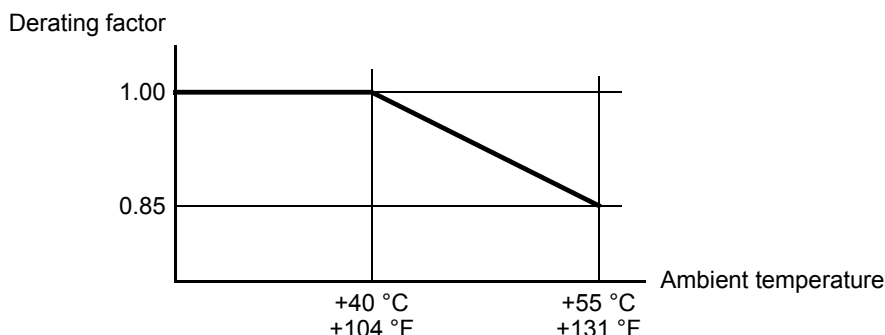

Altitude derating

At altitudes from 1000 to 4000 m (3300 to 13123 ft) above sea level, the derating is 1% for every 100 m (328 ft). For a more accurate derating, use the DriveSize PC tool.

Note: If the installation site is higher than 2000 m (6600 ft) above sea level, connection of the drive to an ungrounded (IT) or corner-grounded delta network is not allowed.

Low motor noise derating

Low motor noise is activated with a drive parameter (see the *Firmware Manual*). With low motor noise, drive loadability is reduced and derating must be applied if a certain constant output current is needed. The derated values are given in the tables below.

Deratings with 230 V AC supply in low motor noise mode

Drive type ACS850-04...	Frame size	Input ratings		Output ratings									
				Nominal		No-overload use		Light-overload use			Heavy-duty use		
		I_{1N} A	$*I_{1N}$ A	I_{2N} A	I_{Max} A	P_N		I_{Ld} A	P_{Ld} kW	P_{Ld} HP	I_{Hd} A	P_{Hd} kW	P_{Hd} HP
-03A0-2	A	1.7	2.9	2.5	4.4	0.37	0.5	2.3	0.25	0.5	1.8	0.25	0.25
-03A6-2	A	2.4	4.4	3	5.3	0.37	0.5	2.8	0.37	0.5	2.2	0.25	0.5
-04A8-2	A	3.1	5.3	4	7.0	0.55	0.75	3.8	0.55	0.75	3.0	0.37	0.5
-06A0-2	A	4.4	7.4	5	8.8	0.75	1	4.8	0.75	1	3.8	0.55	0.75
-08A0-2	A	4.5	7.6	5.7	10.5	1.1	1	5.2	0.75	1	4.2	0.75	1
-010A-2	B	7.5	11.5	9.5	13.5	1.5	2	9.0	1.5	2	6.8	1.1	2
-014A-2	B	9.4	14	12	16.5	2.2	3	11.4	2.2	3	8.8	1.5	2
-018A-2	B	11	15	13	21	3	3	12.2	2.2	3	9.9	2.2	3
-025A-2	C	12	–	16	33	3	5	15.2	3	5	12	2.2	3
-030A-2	C	17	–	20	36	4	5	19	4	5	14	3	3
-035A-2	C	20	–	23	44	5.5	7.5	22	4	7.5	17	4	5
-044A-2	C	23	–	29	53	5.5	10	27	5.5	7.5	22	5.5	7.5
-050A-2	C	28	–	33	66	7.5	10	31	7.5	10	26	5.5	7.5
-061A-2	D	37	–	42	78	7.5	15	37	7.5	10	31	7.5	10
-078A-2	D	42	–	51	100	11	15	48	11	15	41	7.5	15
-094A-2	D	53	–	61	124	15	20	58	15	20	45	11	15

581898

Deratings with 400 V AC supply in low motor noise mode

Drive type ACS850-04...	Frame size	Input ratings		Output ratings						
				Nominal		No-overload use	Light-overload use		Heavy-duty use	
		I_{1N} A	$*I_{1N}$ A	I_{2N} A	I_{Max} A	P_N kW	I_{Ld} A	P_{Ld} kW	I_{Hd} A	P_{Hd} kW
-03A0-5	A	1.9	3.2	2.5	4.4	0.75	2.3	0.75	1.8	0.55
-03A6-5	A	2.6	4.7	3	5.3	1.1	2.8	1.1	2.2	0.75
-04A8-5	A	3.3	5.7	4	7.0	1.5	3.8	1.5	3	1.1
-06A0-5	A	4.6	7.8	5	8.8	2.2	4.8	1.5	3.8	1.5
-08A0-5	A	4.6	7.7	5.5	10.5	2.2	5.2	2.2	4.2	1.5
-010A-5	B	7.9	12	9.5	13.5	4	9	4	6.8	3
-014A-5	B	10	15	12	16.5	5.5	11.4	5.5	8.8	4
-018A-5	B	11	16	13	21	5.5	12.2	5.5	9.4	4
-025A-5	C	13	–	16	33	7.5	15	5.5	12	5.5
-030A-5	C	17	–	20	36	7.5	19	7.5	14	5.5
-035A-5	C	20	–	23	44	11	22	7.5	17	7.5
-044A-5	C	24	–	29	53	11	27	11	21	7.5
-050A-5	C	28	–	33	66	15	31	15	26	11
-061A-5	D	36	–	40	78	18.5	37	18.5	31	15
-078A-5	D	43	–	51	100	22	48	22	41	18.5
-094A-5	D	53	–	61	124	30	58	30	44	22

581898

Deratings with 460 V AC supply in low motor noise mode

Drive type ACS850-04...	Frame size	Input ratings		Output ratings						
				Nominal		No-overload use	Light-overload use		Heavy-duty use	
		I_{1N} A	$*I_{1N}$ A	I_{2N} A	I_{Max} A	P_N HP	I_{Ld} A	P_{Ld} HP	I_{Hd} A	P_{Hd} HP
-03A0-5	A	1.6	2.7	2.1	4.4	1	1.9	0.75	1.5	0.5
-03A6-5	A	2.3	4.1	2.6	5.3	1	2.4	1	1.9	0.75
-04A8-5	A	2.8	4.8	3.4	7.0	2	3.2	1.5	2.6	1
-06A0-5	A	4.0	6.7	4.3	8.8	2	4.1	2	3.3	1.5
-08A0-5	A	4.0	6.7	4.8	10.5	3	4.4	2	3.6	2
-010A-5	B	6.7	10	8	13.5	5	7.7	5	5.8	3
-014A-5	B	9	13	10	16.5	5	9.7	5	7.6	5
-018A-5	B	10	14	12	21	7.5	11	7.5	8	5
-025A-5	C	11	–	14	33	10	13	7.5	11	7.5
-030A-5	C	15	–	17	36	10	16	10	12	7.5
-035A-5	C	18	–	21	44	15	20	10	15	10
-044A-5	C	20	–	25	53	15	23	15	18	10
-050A-5	C	24	–	29	66	20	27	20	22	15
-061A-5	D	31	–	34	78	25	31	20	27	20
-078A-5	D	36	–	43	100	30	41	30	34	25
-094A-5	D	45	–	52	124	40	49	30	38	25

581898

Deratings with 500 V AC supply in low motor noise mode

Drive type ACS850-04...	Frame size	Input ratings		Output ratings						
				Nominal		No-overload use	Light-overload use		Heavy-duty use	
		I_{1N} A	$*I_{1N}$ A	I_{2N} A	I_{Max} A	P_N kW	I_{Ld} A	P_{Ld} kW	I_{Hd} A	P_{Hd} kW
-03A0-5	A	1.6	2.7	2.1	4.4	0.75	1.9	0.75	1.5	0.55
-03A6-5	A	2.3	4.1	2.6	5.3	1.1	2.4	1.1	1.9	0.75
-04A8-5	A	2.8	4.8	3.4	7.0	1.5	3.2	1.5	2.6	1.1
-06A0-5	A	4.0	6.7	4.3	8.8	2.2	4.1	1.5	3.3	1.5
-08A0-5	A	4.0	6.7	4.8	10.5	2.2	4.4	2.2	3.6	1.5
-010A-5	B	6.7	10	8	13.5	4	7.7	4	5.8	3
-014A-5	B	9	13	10	16.5	5.5	9.7	4	7.6	4
-018A-5	B	10	14	12	21	5.5	11	5.5	8	4
-025A-5	C	11	–	14	33	7.5	13	5.5	11	5.5
-030A-5	C	15	–	17	36	7.5	16	7.5	12	5.5
-035A-5	C	18	–	21	44	11	20	11	15	7.5
-044A-5	C	20	–	25	53	11	23	11	18	7.5
-050A-5	C	24	–	29	66	15	27	15	22	11
-061A-5	D	31	–	34	78	18.5	31	18.5	27	15
-078A-5	D	36	–	43	100	22	41	22	34	18.5
-094A-5	D	45	–	52	124	30	49	30	38	22

581898

Symbols

For the symbols used in the tables above, see page 79.

Dimensions and weights

See also chapter *Dimension drawings* on page 113.

Frame size	Height (without cable clamp plates) mm (in.)	Height (with cable clamp plates) mm (in.)	Width mm (in.)	Depth (without control panel) mm (in.)	Depth (with control panel) mm (in.)	Weight kg (lbs)
A	364 (14.33)	474 (18.66)	93.5 (3.68)	197 (7.76)	219 (8.62)	3.2 (7.1)
B	380 (14.96)	476 (18.74)	101 (3.98)	274 (10.79)	297 (11.69)	5.4 (11.9)
C	567 (22.32)	658 (25.91)	166 (6.54)	276 (10.87)	298 (11.73)	15.6 (34.4)
D	567 (22.32)	744 (29.29)	221 (8.70)	276 (10.87)	298 (11.73)	21.3 (47)

Cooling characteristics, noise levels

Drive type ACS850-04 ...	Power loss W (BTU/h)					Air flow m ³ /h (ft ³ /min)	Noise level dBA
	Load						
	0%	25%	50%	75%	100%		
-03A0-2	66 (226)	71 (244)	77 (264)	84 (287)	91 (312)	24 (14)	47
-03A6-2	66 (226)	73 (247)	80 (272)	88 (300)	97 (332)	24 (14)	47
-04A8-2	72 (245)	80 (273)	90 (307)	101 (346)	114 (390)	24 (14)	47
-06A0-2	72 (245)	83 (284)	97 (332)	114 (390)	134 (457)	24 (14)	47
-08A0-2	72 (245)	87 (298)	106 (363)	129 (439)	154 (526)	24 (14)	47
-010A-2	72 (245)	91 (311)	116 (395)	147 (500)	183 (626)	48 (28)	39
-014A-2	76 (259)	100 (342)	132 (449)	170 (579)	215 (733)	48 (28)	39
-018A-2	76 (259)	109 (371)	152 (520)	208 (709)	274 (936)	48 (28)	39
-025A-2	92 (314)	137 (469)	191 (653)	254 (867)	325 (1109)	142 (84)	71
-030A-2	92 (314)	152 (520)	227 (776)	317 (1082)	421 (1438)	142 (84)	71
-035A-2	95 (323)	160 (545)	239 (816)	333 (1137)	442 (1507)	142 (84)	71
-044A-2	97 (332)	167 (570)	251 (856)	349 (1192)	462 (1576)	200 (118)	71
-050A-2	97 (332)	182 (620)	286 (975)	410 (1400)	555 (1894)	200 (118)	71
-061A-2	115 (393)	224 (763)	362 (1236)	531 (1812)	730 (2492)	290 (171)	70
-078A-2	115 (393)	249 (851)	423 (1444)	636 (2172)	889 (3034)	290 (171)	70
-094A-2	115 (393)	272 (929)	481 (1641)	741 (2530)	1054 (3597)	290 (171)	70
-03A0-5	68 (233)	75 (256)	83 (282)	91 (310)	100 (340)	24 (14)	47
-03A6-5	68 (233)	76 (261)	86 (292)	96 (326)	106 (363)	24 (14)	47
-04A8-5	74 (252)	84 (288)	97 (330)	110 (376)	126 (430)	24 (14)	47
-06A0-5	74 (252)	88 (302)	106 (361)	126 (429)	148 (504)	24 (14)	47
-08A0-5	74 (252)	93 (319)	116 (397)	142 (486)	172 (586)	24 (14)	47
-010A-5	77 (261)	101 (345)	132 (450)	169 (576)	212 (722)	48 (28)	39
-014A-5	80 (273)	112 (382)	151 (515)	197 (672)	250 (852)	48 (28)	39
-018A-5	80 (273)	122 (418)	176 (601)	241 (823)	318 (1084)	48 (28)	39
-025A-5	98 (333)	154 (525)	219 (747)	293 (1000)	375 (1282)	142 (84)	63
-030A-5	98 (333)	172 (588)	262 (893)	366 (1249)	485 (1654)	142 (84)	63
-035A-5	100 (342)	181 (619)	277 (947)	388 (1323)	513 (1750)	142 (84)	63
-044A-5	103 (351)	191 (651)	293 (1000)	410 (1398)	541 (1846)	200 (118)	71
-050A-5	103 (351)	209 (712)	335 (1142)	481 (1641)	646 (2205)	200 (118)	71
-061A-5	126 (430)	259 (884)	422 (1441)	616 (2101)	840 (2867)	290 (171)	70
-078A-5	126 (430)	290 (990)	494 (1685)	737 (2514)	1020 (3481)	290 (171)	70
-094A-5	126 (430)	317 (1081)	560 (1910)	854 (2915)	1200 (4096)	290 (171)	70

Supply cable fuses

Fuses for short circuit protection of the supply cable are listed below. The fuses also protect the adjoining equipment of the drive in case of a short circuit. Check that the operating time of the fuse is below 0.5 seconds. The operating time depends on the supply network impedance and the cross-sectional area and length of the supply cable. See also chapter [Planning the electrical installation](#).

Note: Fuses with a higher current rating must not be used.

Drive type ACS850-04...	Input current (A)	IEC fuse			UL fuse			Cross-sectional area of cable	
		Rated current (A)	Voltage (V)	Class	Rated current (A)	Voltage (V)	UL Class	mm ²	AWG
-03A0-2, -03A0-5	4.0*	6	500	gG	6	600	T	1.5...4	16...12
-03A6-2, -03A6-5	6.0*	6	500	gG	6	600	T	1.5...4	16...12
-04A8-2, -04A8-5	7.0*	10	500	gG	10	600	T	1.5...4	16...12
-06A0-2, -06A0-5	9.0*	10	500	gG	10	600	T	1.5...4	16...12
-08A0-2, -08A0-5	11*	16	500	gG	15	600	T	1.5...4	16...12
-010A-2, -010A-5	13*	16	500	gG	15	600	T	1.5...10	16...8
-014A-2, -014A-5	18*	20	500	gG	20	600	T	1.5...0	16...8
-018A-2, -018A-5	23*	25	500	gG	25	600	T	1.5...10	16...8
-025A-2, -025A-5	20	25	500	gG	25	600	T	6...35	9...2
-030A-2, -030A-5	26	32	500	gG	35	600	T	6...35	9...2
-035A2, -035A-5	30	40	500	gG	35	600	T	6...35	9...2
-044A-2, -044A-5	36	50	500	gG	45	600	T	6...35	9...2
-050A-2, -050A-5	42	50	500	gG	50	600	T	10...70	6...2/0
-061A-2, -061A-5	55	63	500	gG	70	600	T	10...70	6...2/0
-078A-2, -078A-5	65	80	500	gG	80	600	T	10...70	6...2/0
-094A-2, -094A-5	82	100	500	gG	100	600	T	10...70	6...2/0

*Without mains choke

AC input (supply) connection

Voltage (U_1)	200...240 V AC +/-10%, 3-phase 380...500 V AC +10%/-15%, 3-phase
Frequency	50...60 Hz \pm 5%
Short-circuit withstand strength (IEC 60439-1)	Frames A and B: Maximum allowable prospective short-circuit current is 5 kA when protected by fuses given in the Supply cable fuses table. Frames C and D: Maximum allowable prospective short-circuit current is 10 kA when protected by fuses given in the Supply cable fuses tables.
Network type	Grounded (TN, TT) or ungrounded (IT). Note: Connection to an ungrounded (IT) or corner-grounded delta network is not allowed at altitudes of 2000 m (6600 ft) or higher.
Imbalance	Max. \pm 3% of nominal phase to phase input voltage
Fundamental power factor ($\cos \phi_1$)	0.98 (at nominal load)
Terminals	Frame A: Detachable screw terminal block for 0.25...4 mm ² wire. Frame B: Detachable screw terminal block for 0.5...6 mm ² wire. Frames C and D: Screw lugs for 6...70 mm ² wire included. Suitable crimp lugs can be used instead.

DC connection

Voltage	243...356 V DC (ACS850-04-xxxx-2 drives) 436...743 V DC (ACS850-04-xxxx-5 drives)
----------------	--

Ratings, fuse recommendations

Drive type ACS850-04...	I_{dcN} (A)	C (μ F)	IEC fuse			UL fuse		
			Rated current (A)	Voltage (V)	Class	Rated current (A)	Voltage (V)	Class
-03A0-2, -03A0-5	3.3	120	16	690	aR	TBA		
-03A6-2, -03A6-5	3.9	120	16	690	aR			
-04A8-2, -04A8-5	4.8	240	16	690	aR			
-06A0-2, -06A0-5	6.5	240	16	690	aR			
-08A0-2, -08A0-5	8.7	240	16	690	aR			
-010A-2, -010A-5	12	370	20	690	aR			
-014A-2, -014A-5	15	740	32	690	aR			
-018A-2, -018A-5	20	740	32	690	aR			
-025A-2, -025A-5	29	670	63	690	aR			
-030A-2, -030A-5	38	670	63	690	aR			
-035A2, -035A-5	44	1000	100	690	aR			
-044A-2, -044A-5	54	1000	100	690	aR			
-050A-2, -050A-5	54	1000	100	690	aR			
-061A-2, -061A-5	73	1340	160	690	aR			
-078A-2, -078A-5	85	2000	160	690	aR			
-094A-2, -094A-5	98	2000	160	690	aR			

I_{dcN}	Average DC input current requirement when running a typical induction motor at P_N at a DC link voltage of 540 V (which corresponds to an AC input voltage of 400 V).
C	Capacitance of DC link.

Terminals	Frame A: Detachable screw terminal block for 0.25...4 mm ² wire. Frame B: Detachable screw terminal block for 0.5...6 mm ² wire. Frames C and D: Screw lugs for 6...70 mm ² wire included. Suitable crimp lugs can be used instead.
------------------	--

Motor connection

Motor types	Asynchronous induction motors, synchronous permanent magnet motors
Frequency	0...500 Hz
Current	See section Ratings .
Switching frequency	3 kHz (default)
Maximum motor cable length	Frames A and B: 150 m (492 ft) * Frames C and D: 300 m (984 ft) * *100 m with EN 61800-3 Category C3 filter
Terminals	Frame A: Detachable screw terminal block for 0.25...4 mm ² wire. Frame B: Detachable screw terminal block for 0.5...6 mm ² wire. Frames C and D: Screw lugs for 6...70 mm ² wire included. Suitable crimp lugs can be used instead.

JCU Control Unit

Power supply	24 V (±10%) DC, 1.6 A Supplied from the power unit of the drive, or from an external power supply through connector XPOW (pitch 5 mm, wire size 2.5 mm ²).
Relay outputs RO1...RO3 (XRO1 ... XRO3)	Connector pitch 5 mm, wire size 2.5 mm ² 250 V AC / 30 V DC, 2 A Protected by varistors Note: The relay outputs of the drive do not fulfill the Protective Extra Low Voltage (PELV) requirements at installation sites above 4000 meters (13123 feet) if used with a voltage greater than 48 V. At installation sites between 2000 meters (6562 feet) and 4000 meters (13123 feet), PELV requirements are not fulfilled if one or two relay outputs are used with a voltage greater than 48 V and the remaining relay output(s) are used with a voltage lower than 48 V.
+24 V output (XD24)	Connector pitch 5 mm, wire size 2.5 mm ²
Digital inputs DI1...DI6 (XDI:1 ... XDI:6)	Connector pitch 3.5 mm, wire size 1.5 mm ² 24 V logic levels: "0" < 5 V, "1" > 15 V R_{in} : 2.0 kohm Input type: NPN/PNP (DI1...DI5), NPN (DI6) Filtering: 0.25 ms DI6 (XDI:6) can alternatively be used as an input for 1...3 PTC thermistors. "0" > 4 kohm, "1" < 1.5 kohm I_{max} : 15 mA
Start interlock input DII1 (XDI:A)	Wire size 1.5 mm ² 24 V logic levels: "0" < 5 V, "1" > 15 V R_{in} : 2.0 kohm Input type: NPN/PNP Filtering: 0.25 ms

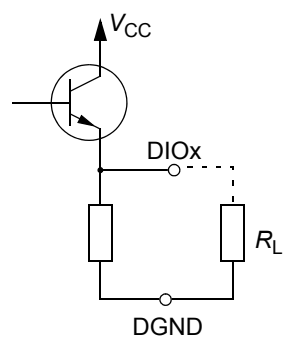
<p>Digital inputs/outputs DIO1 and DIO2 (XDIO:1 and XDIO:2)</p> <p>Input/output mode selection by parameters.</p> <p>DIO1 can be configured as a frequency input (0...16 kHz) for 24 V level square wave signal (sinusoidal or other wave form cannot be used). DIO2 can be configured as a 24 V level square wave frequency output. See <i>Firmware Manual</i>, parameter group 12.</p>	<p>Connector pitch 3.5 mm, wire size 1.5 mm²</p> <p><u>As inputs:</u> 24 V logic levels: "0" < 5 V, "1" > 15 V R_{in}: 2.0 kohm Filtering: 0.25 ms</p> <p><u>As outputs:</u> Total output current limited by auxiliary voltage outputs to 200 mA Output type: Open emitter</p> 
<p>Reference voltage for analog inputs +VREF and -VREF (XAI:1 and XAI:2)</p>	<p>Connector pitch 3.5 mm, wire size 1.5 mm² 10 V ±1% and -10 V ±1%, $R_{load} > 1$ kohm</p>
<p>Analog inputs AI1 and AI2 (XAI:4 ... XAI:7).</p> <p>Current/voltage input mode selection by jumpers. See page 63.</p>	<p>Connector pitch 3.5 mm, wire size 1.5 mm² Current input: -20...20 mA, R_{in}: 100 ohm Voltage input: -10...10 V, R_{in}: 200 kohm Differential inputs, common mode ±20 V Sampling interval per channel: 0.25 ms Filtering: 0.25 ms Resolution: 11 bit + sign bit Inaccuracy: 1% of full scale range</p>
<p>Analog outputs AO1 and AO2 (XAO)</p>	<p>Connector pitch 3.5 mm, wire size 1.5 mm² 0...20 mA, $R_{load} < 500$ ohm Frequency range: 0...800 Hz Resolution: 11 bit + sign bit Inaccuracy: 2% of full scale range</p>
<p>Drive to drive link (XD2D)</p>	<p>Connector pitch 3.5 mm, wire size 1.5 mm² Physical layer: RS-485 Termination by jumper</p>
<p>Safe torque off connection (XSTO)</p>	<p>Connector pitch 3.5 mm, wire size 1.5 mm² For the drive to start, both connections (OUT1 to IN1, and OUT2 to IN2) must be closed</p>
<p>Control panel / PC connection</p>	<p>Connector: RJ-45 Cable length < 3 m</p>

Isolation and grounding diagram

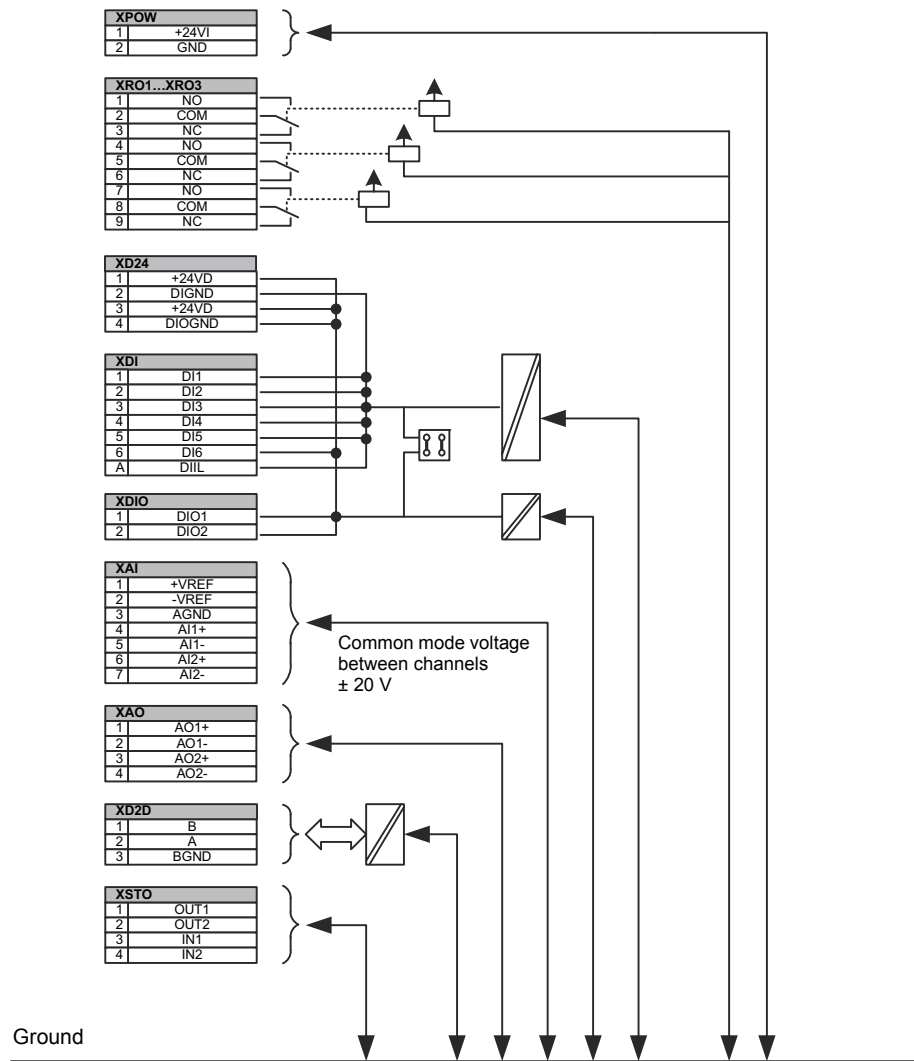

Efficiency

Approximately 98% at nominal power level

Cooling

Method Internal fan, flow from bottom to top. Air-cooled heatsink.

Free space around the unit See chapter [Planning the cabinet assembly](#).

Degrees of protection

IP20 (UL open type). See chapter [Planning the cabinet assembly](#).

Ambient conditions

Environmental limits for the drive are given below. The drive is to be used in a heated, indoor, controlled environment.

	Operation installed for stationary use	Storage in the protective package	Transportation in the protective package
Installation site altitude	0 to 4000 m (13123 ft) above sea level. [See also section Altitude derating on page 80.]	-	-
Air temperature	-10 to +55°C (14 to 131°F). No frost allowed. See section Derating on page 79.	-40 to +70°C (-40 to +158°F)	-40 to +70°C (-40 to +158°F)
Relative humidity	0 to 95%	Max. 95%	Max. 95%
	No condensation allowed. Maximum allowed relative humidity is 60% in the presence of corrosive gases.		
Contamination levels (IEC 60721-3-3, IEC 60721-3-2, IEC 60721-3-1)	No conductive dust allowed.		
	According to IEC 60721-3-3: Chemical gases: Class 3C2 Solid particles: Class 3S2 The drive must be installed in clean air according to enclosure classification. Cooling air must be clean, free from corrosive materials and electrically conductive dust.	According to IEC 60721-3-1: Chemical cases: Class 1C2 Solid particles: Class 1S2	According to IEC 60721-3-2: Chemical cases: Class 2C2 Solid particles: Class 2S2
Sinusoidal vibration (IEC 60721-3-3)	Tested according to IEC 60721-3-3, mechanical conditions: Class 3M4 2...9 Hz: 3.0 mm (0.12") 9...200 Hz: 10 m/s ² (33 ft/s ²)	-	-
Shock (IEC 60068-2-27, ISTA 1A)	-	According to ISTA 1A. Max. 100 m/s ² (330 ft/s ²), 11 ms	According to ISTA 1A. Max. 100 m/s ² (330 ft/s ²), 11 ms
Free fall	Not allowed	76 cm (30")	76 cm (30")

Materials

Drive enclosure

- PC/ABS, colour NCS 1502-Y (RAL 9002 / PMS 420 C)
- hot-dip zinc coated steel sheet
- extruded aluminium AlSi.

Packaging

Corrugated cardboard, PP bands.

Disposal

The drive contains raw materials that should be recycled to preserve energy and natural resources. The package materials are environmentally compatible and recyclable. All metal parts can be recycled. The plastic parts can either be recycled or burned under controlled circumstances, according to local regulations. Most recyclable parts are marked with recycling marks.

If recycling is not feasible, all parts excluding electrolytic capacitors and printed circuit boards can be landfilled. The DC capacitors contain electrolyte, which is classified as hazardous waste within the EU. They must be removed and handled according to local regulations.

For further information on environmental aspects and more detailed recycling instructions, please contact your local ABB distributor.

Applicable standards

- The drive complies with the following standards. The compliance with the European Low Voltage Directive is verified according to standards EN 50178 and EN 60204-1.
- EN 50178:1997 Electronic equipment for use in power installations
 - IEC 60204-1:2006 Safety of machinery. Electrical equipment of machines. Part 1: General requirements.
Provisions for compliance: The final assembler of the machine is responsible for installing
 - an emergency-stop device
 - a supply disconnecting device
 - the drive module into a cabinet.
 - EN 60529:1991 (IEC 60529) Degrees of protection provided by enclosures (IP code)
 - IEC 60664-1:2007 Insulation coordination for equipment within low-voltage systems. Part 1: Principles, requirements and tests.
 - IEC 61800-3:2004 Adjustable speed electrical power drive systems. Part 3: EMC requirements and specific test methods.
 - EN 61800-5-1:2003 Adjustable speed electrical power drive systems.
Part 5-1: Safety requirements. Electrical, thermal and energy
Provisions for compliance: The final assembler of the machine is responsible for installing the ACS850-04 in a cabinet that is protected to IP3X for top surfaces for vertical access.
 - EN 61800-5-2:2007 Adjustable speed electrical power drive systems.
Part 5-2: Safety requirements. Functional
 - UL 508C:2002, Third Edition UL Standard for Safety, Power Conversion Equipment
 - NEMA 250:2003 Enclosures for Electrical Equipment (1000 Volts Maximum)
 - CSA C22.2 No. 14-05 Industrial Control Equipment
(2005)

CE marking

A CE mark is attached to the drive to verify that the drive follows the provisions of the European Low Voltage and EMC Directives (Directive 2006/95/EC and Directive 2004/108/EC).

Compliance with the European Low Voltage Directive

The compliance with the European Low Voltage Directive has been verified according to standards EN 50178, EN 61800-5-1 and EN 60204-1.

Compliance with the European EMC Directive

The cabinet builder is responsible for the compliance of the drive system with the European EMC Directive. For information on items to consider, see:

- Subsections [Compliance with EN 61800-3:2004, category C2](#); [Compliance with EN 61800-3:2004, category C3](#); and [Compliance with EN 61800-3:2004, category C4](#) below
- Chapter [Planning the electrical installation](#) in this manual
- *Technical Guide No. 3 – EMC Compliant Installation and Configuration for a Power Drive System* (3AFE61348280 [English]).

Definitions

EMC stands for **Electromagnetic Compatibility**. It is the ability of electrical/electronic equipment to operate without problems within an electromagnetic environment. Likewise, the equipment must not disturb or interfere with any other product or system within its locality.

First environment includes domestic premises. It also includes establishments directly connected without intermediate transformers to a low-voltage network which supplies buildings used for domestic purposes.

Second environment includes all establishments other than those directly connected to a low-voltage network which supplies buildings used for domestic purposes.

Drive of category C2. Power drive system with rated voltage less than 1000 V which is neither a plug-in device nor a movable device and, when used in the first environment, is intended to be installed and commissioned only by a professional.

Drive of category C3. Power drive system with rated voltage less than 1000 V, intended for use in the second environment and not intended for use in the first environment.

Drive of category C4. Power drive system with rated voltage equal to or above 1000 V, or rated current equal to or above 400 A, or intended for use in complex systems in the second environment.

Compliance with EN 61800-3:2004, category C2

The drive meets the requirements of the EMC Directive with the following provisions:

1. The drive is equipped with external EMC filter JFI-0x (optional accessory).
2. The motor and control cables are selected as specified in chapter [Planning the electrical installation](#).
3. The drive is installed according to the instructions given in this manual.
4. Motor cable length does not exceed 100 metres (328 ft).

Note: It is not allowed to use the optional EMC filter on IT (ungrounded) systems. The supply network becomes connected to ground potential through the EMC filter capacitors which may cause danger or damage the drive.

Note: It is not allowed to use the optional EMC filter on a corner-grounded TN system as this would damage the drive.



WARNING! The drive may cause radio interference if used in a residential or domestic environment. The user is required to take measures to prevent interference, in addition to the requirements for CE compliance listed above, if necessary.

Compliance with EN 61800-3:2004, category C3

The drive meets the requirements of the EMC Directive with the following provisions:

1. The drive is equipped with filtering option +E200.
2. The motor and control cables are selected as specified in chapter [Planning the electrical installation](#).
3. The drive is installed according to the instructions given in this manual.
4. Motor cable length does not exceed 100 metres (328 ft).

Compliance with EN 61800-3:2004, category C4

The drive meets the requirements of the EMC Directive with the following provisions:

1. It is ensured that no excessive emission is propagated to neighbouring low-voltage networks. In some cases, the natural suppression in transformers and cables is sufficient. If in doubt, a supply transformer with static screening between the primary and secondary windings can be used.

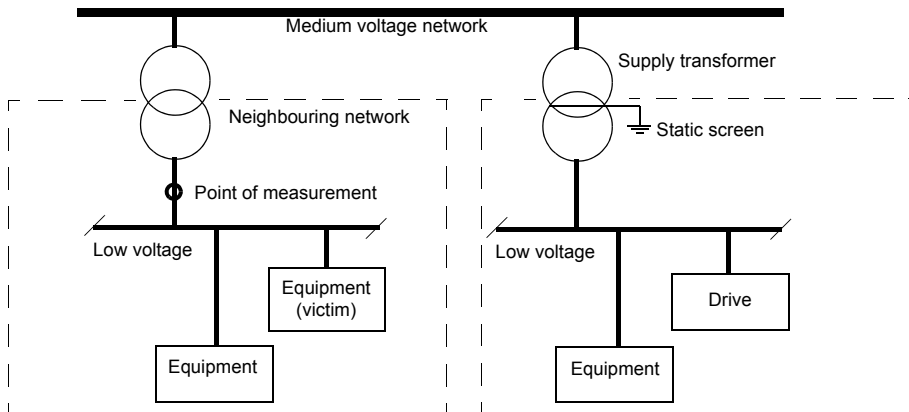

2. An EMC plan for preventing disturbances is drawn up for the installation. A template is available from the local ABB representative.
3. The motor and control cables are selected as specified in chapter [Planning the electrical installation](#).
4. The drive is installed according to the instructions given in this manual.

Compliance with the Machinery Directive

The drive complies with the European Machinery Directive requirements for a partly completed machinery.



Declaration of Incorporation

(According to Machinery Directive 98/37/EC art. 4.2 and Annex II, Sub B)

Manufacturer: ABB Oy

Address: P.O Box 184, FIN-00381 Helsinki, Finland. Street address: Hiomotie 13,

herewith declare under our sole responsibility that the product:

Frequency converter series ACS850 with current rating from 3 A up to 720 A and type marking ACS850-04

are intended to be incorporated into machinery to constitute machinery covered by the EEC directive 98/37/EC;

do therefore not in every respect comply with the provisions of this directive;

and that the following harmonised European standard has been applied:

EN 60204-1 (1997 + corrigendum Sep.1998)

Safety of machinery - Electrical equipment of machines- Part 1: general requirements

and that the following technical standard have been used:

EN 60529 (1991 + corrigendum May 1993 + amendment A1:2000)

Degrees of protection provided by enclosures (IP codes)

and furthermore declares that

it is not allowed to put the equipment into service until the machinery into which it is to be incorporated or of which it is to be a component has been found and declared to be in conformity with the provisions of the Directive 98/37/EC and with national implementing legislation, i.e. as a whole, including the equipment referred to in this Declaration.

Helsinki, 31.3.2009

A handwritten signature in black ink, appearing to read 'Jukka Poutanen', with a long horizontal stroke extending to the right.

Jukka Poutanen

Vice President
ABB Oy, Drives

C-Tick marking

A C-Tick mark is attached to each drive in order to verify compliance with the EMC product standard (EN 61800-3:2004), required under the Trans-Tasman Electromagnetic Compatibility Scheme for levels 1, 2 and 3 in Australia and New Zealand.

Note: To meet the standard, the installation of the drive must meet the requirements described under section [Compliance with the European EMC Directive](#) on page 91.

UL marking

See the type designation label for the valid markings of your drive.

UL checklist

Input power connection – See section [AC input \(supply\) connection](#) on page 85.

Disconnecting device (Disconnecting means) – See section [Supply disconnecting device](#) on page 39.

Ambient conditions – The drive is to be used in a heated indoor controlled environment. See section [Ambient conditions](#) on page 89 for specific limits.

Input cable fuses – For installation in the United States, branch circuit protection must be provided in accordance with the National Electrical Code (NEC) and any applicable local codes. To fulfill this requirement, use the UL classified fuses given in section [Supply cable fuses](#) on page 84.

For installation in Canada, branch circuit protection must be provided in accordance with the Canadian Electrical Code and any applicable provincial codes. To fulfil this requirement, use the UL classified fuses given in section [Supply cable fuses](#) on page 84.

Power cable selection – See section [Selecting the power cables](#) on page 43.

Power cable connections – For the connection diagram and tightening torques, see section [Power cable connection](#) on page 52.

Control connections – For the connection diagram and tightening torques, see section [Connecting the control cables](#) on page 62.

Overload protection – The drive provides overload protection in accordance with the National Electrical Code (US).

Braking – The ACS850-04 has an internal braking chopper. When applied with appropriately sized braking resistors, the braking chopper will allow the drive to dissipate regenerative energy (normally associated with quickly decelerating a motor). Braking resistor selection is discussed in chapter [Resistor braking](#) on page 109.

UL standards – See section [Applicable standards](#) on page 90.

Patent protection in the US

This product is protected by one or more of the following US patents:

4,920,306	5,301,085	5,463,302	5,521,483	5,532,568	5,589,754
5,612,604	5,654,624	5,799,805	5,940,286	5,942,874	5,952,613
6,094,364	6,147,887	6,175,256	6,184,740	6,195,274	6,229,356
6,252,436	6,265,724	6,305,464	6,313,599	6,316,896	6,335,607
6,370,049	6,396,236	6,448,735	6,498,452	6,552,510	6,597,148
6,600,290	6,741,059	6,774,758	6,844,794	6,856,502	6,859,374
6,922,883	6,940,253	6,934,169	6,956,352	6,958,923	6,967,453
6,972,976	6,977,449	6,984,958	6,985,371	6,992,908	6,999,329
7,023,160	7,034,510	7,036,223	7,045,987	7,057,908	7,059,390
7,067,997	7,082,374	7,084,604	7,098,623	7,102,325	7,109,780
7,164,562	7,176,779	7,190,599	7,215,099	7,221,152	7,227,325
7,245,197	7,250,739	7,262,577	7,271,505	7,274,573	7,279,802
7,280,938	7,330,095	7,349,814	7,352,220	7,365,622	7,372,696
7,388,765	7,408,791	7,417,408	7,446,268	7,456,615	7,508,688
7,515,447	7,560,894	7,589,984	7,652,602	7,663,850	7,670,163
7,671,548	7,679,425	7,688,845	7,696,532	7,706,396	7,724,503
7,729,148	7,741,796	7,733,048	7,755,501	7,759,897	D503,931
D510,319	D510,320	D511,137	D511,150	D512,026	D512,696
D521,466	D541,743S	D541,744S	D541,745S	D548,182S	D548,183S
D573,090S	D610,553S				

Other patents pending.

Mains chokes

What this chapter contains

This chapter describes how to select and install mains chokes for the ACS850-04. The chapter also contains the relevant technical data.

When is a mains choke required?

Frame C and D drive modules have an internal mains choke. With frames A and B, the need for an external choke should be determined on a case-by-case basis. The main choke typically

- reduces harmonics in the input current
- reduces the r.m.s. input current
- reduces supply disturbance and low-frequency interference
- increases the allowed DC bus continuous power
- ensures even current distribution in common DC configurations (see page [59](#)).

Selection table

<i>Mains chokes for ACS850-04</i>		
Drive type ACS850-04...	Type	Inductance μH
-03A0-2, -03A0-5	CHK-01	6370
-03A6-2, -03A6-5		
-04A8-2, -04A8-5	CHK-02	4610
-06A0-2, -06A0-5		
-08A0-2, -08A0-5		
-010A-2, -010A-5	CHK-03	2700
-014A-2, -014A-5		
-018A-2, -018A-5	CHK-04	1475
-025A-2, -025A-5	(Internal choke as standard)	
-030A-2, -030A-5		
-035A2, -035A-5		
-044A-2, -044A-5		
-050A-2, -050A-5		
-061A-2, -061A-5		
-078A-2, -078A-5		
-094A-2, -094A-5		

581898

The mains chokes are protected to IP20. Refer to page [118](#) for dimensions, wire sizes and tightening torques.

Installation guidelines

- If an EMC filter is also installed, the mains choke is connected between the supply and the EMC filter. See the diagram below.
- For optimal operation of the choke, the drive and the choke must be mounted on the same conductive surface.
- Ensure the choke does not block the airflow through the drive module, and that the air rising from the choke is deflected away from the air inlet of the drive module
- Keep the cable between the drive and the choke as short as possible.



WARNING! The surface of the mains choke becomes hot when in use.

Connection diagram

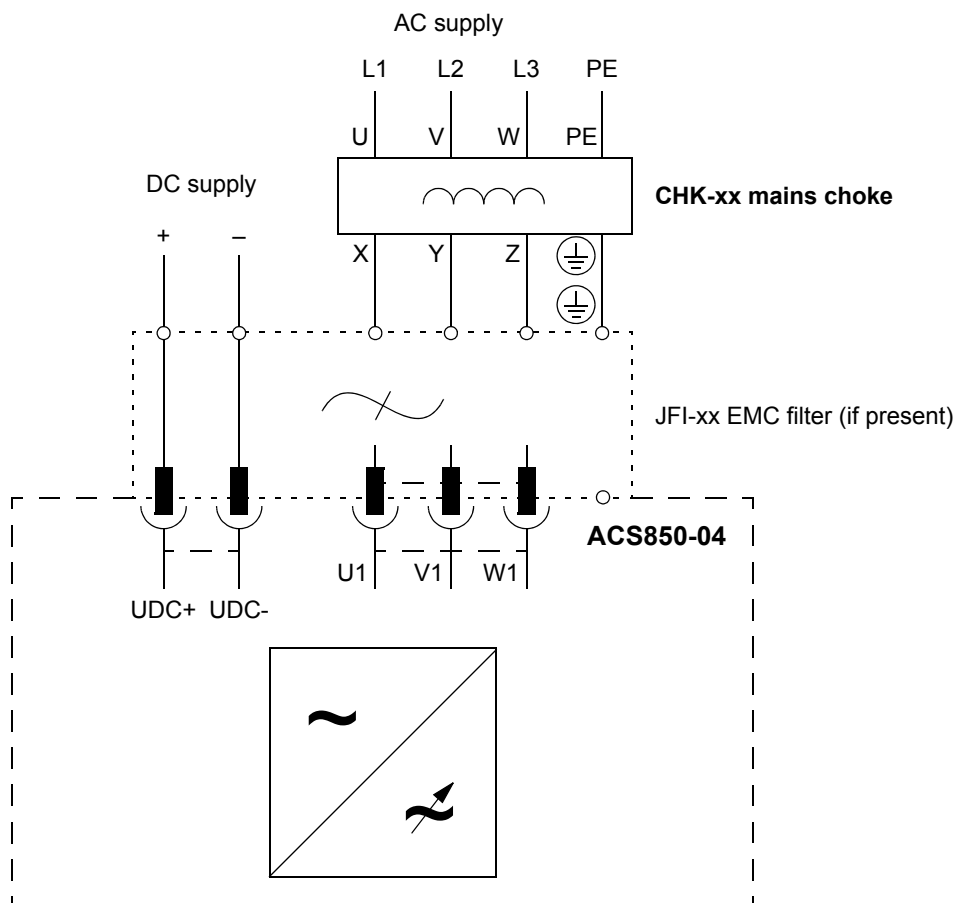

EMC filters

What this chapter contains

This chapter describes how to select and install EMC filters for the ACS850-04. The chapter also contains the relevant technical data.

When is an EMC filter required?

The EMC product standard (EN 61800-3 + Amendment A11 (2000)) covers the specific EMC requirements stated for drives (tested with motor and cable) within the EU. The new revision of 61800-3:2004 product standard can be applied from now on, but from 1st October 2007 at the latest. EMC standards such as EN 55011 or EN 61000-6-3/4 apply to industrial and household equipment and systems including drive components inside. Drive units complying with the requirements of EN 61800-3 are always compliant with comparable categories in EN 55011 and EN 61000-6-3/4, but not necessarily vice versa. EN 55011 and EN 61000-6-3/4 do neither specify cable length nor require a motor to be connected as a load. The emission limits are comparable according to the following table.

<i>EMC standards in general</i>		
EN 61800-3/A11 (2000), product standard	EN 61800-3:2004, product standard	EN 55011, product family standard for industrial, scientific and medical (ISM) equipment
1st environment, unrestricted distribution	Category C1	Group 1 Class B
1st environment, restricted distribution	Category C2	Group 1 Class A
2nd environment, unrestricted distribution	Category C3	Group 2 Class A
2nd environment, restricted distribution	Category C4	Not applicable

Filtering option +E200 is required in order to meet the category C3 level with the ACS850-04 drive installation, including a motor with a max. 100 m cable. This level corresponds to the A limits for Group 2 equipment according to EN 55011. With frame sizes A and B, option +E200 is an external filter of type JFI-A1 or JFI-B1; with frame sizes C and D, the filter is internal.

An external EMC filter of the type JFI-0x is required in order to meet the category C2 level with the ACS850-04 drive installation, including a motor with a max. 100 m cable. This level corresponds to the A limits for Group 1 equipment according to EN 55011.



WARNING! An EMC filter must not be installed if the drive is connected to an IT power system (i.e. an ungrounded, or a high resistance grounded [over 30 ohm] power system).

Selection table

<i>EMC filters for ACS850-04</i>		
Drive type ACS850-04...	Filter type	
	EN 61800-3 (2004): Category C3	EN 61800-3 (2004): Category C2
-03A0-2, -03A0-5	Option code +E200 (external filter JFI-A1)	JFI-02*
-03A6-2, -03A6-5		
-04A8-2, -04A8-5		
-06A0-2, -06A0-5		
-08A0-2, -08A0-5		
-010A-2, -010A-5	Option code +E200 (external filter JFI-B1)	JFI-03*
-014A-2, -014A-5		
-018A-2, -018A-5		
-025A-2, -025A-5	Option code: +E200 (internal filter)	JFI-05*
-030A-2, -030A-5		
-035A2, -035A-5		
-044A-2, -044A-5		
-050A-2, -050A-5		
-061A-2, -061A-5		
-078A-2, -078A-5		JFI-07*
-094A-2, -094A-5		

*External filter; to be ordered separately

All EMC filters are protected to IP20. Refer to page [119](#) for dimensions of the JFI-x1 filters. Refer to page [121](#) for dimensions, wire sizes and tightening torques of the JFI-0x filters.

JFI-A1/JFI-B1 (Frame A/B, category C3) installation

Installation guidelines

- The filter is connected directly to the drive input connectors.
- For optimal operation of the filter, the drive and the filter must be mounted on the same conductive surface.

Connection diagram

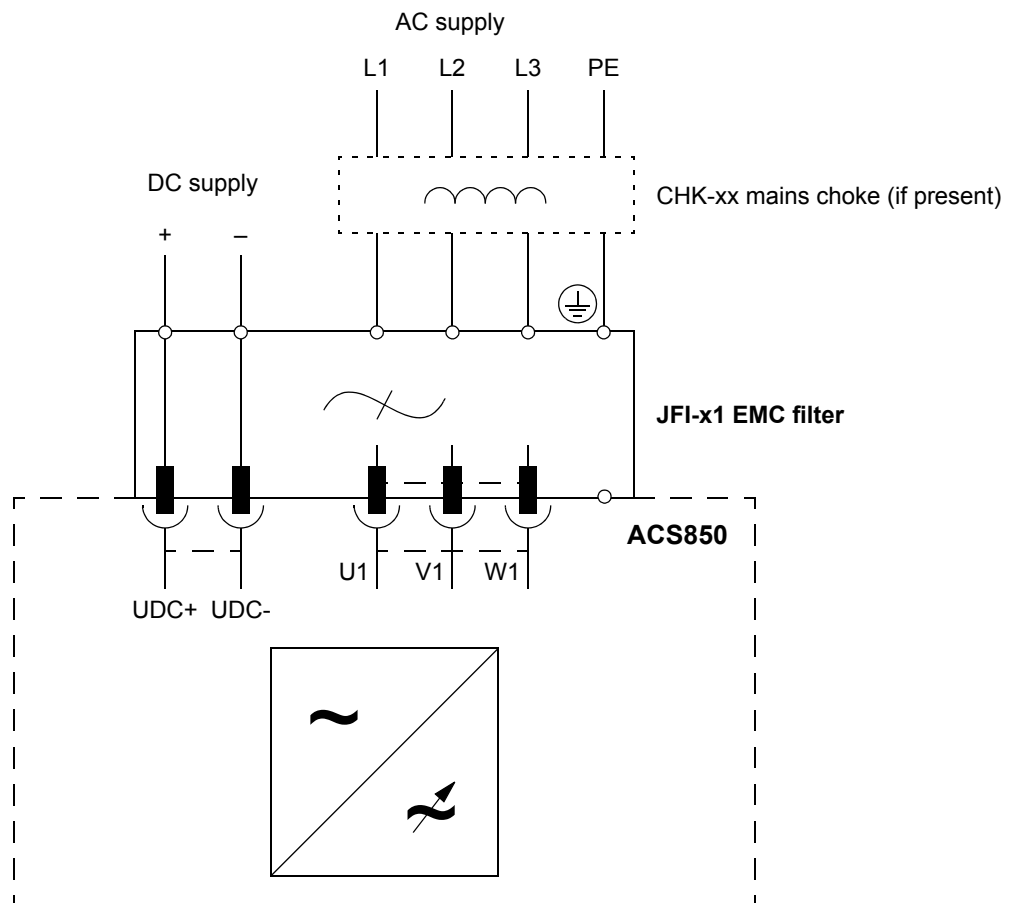

Mounting procedures

JFI-A1

- Remove the UDC+/- and U1/V1/W1 terminal blocks (1), and the upper power cable clamp plate (2) from the drive.
- Fasten the mounting bracket (3) to the drive module base with two screws (4). Tighten to 1.5 N·m (13 lbf·in).
- Push the filter into place through the mounting bracket.
- Fasten the filter to the mounting bracket with two screws (5). Tighten to 1.5 N·m (13 lbf·in).
- Fasten the top edge of the filter to the mounting base with two screws (6).
- Fasten the power cable clamp plate at the top of the filter. Tighten to 1.5 N·m (13 lbf·in).
- Attach the terminal blocks to the filter.

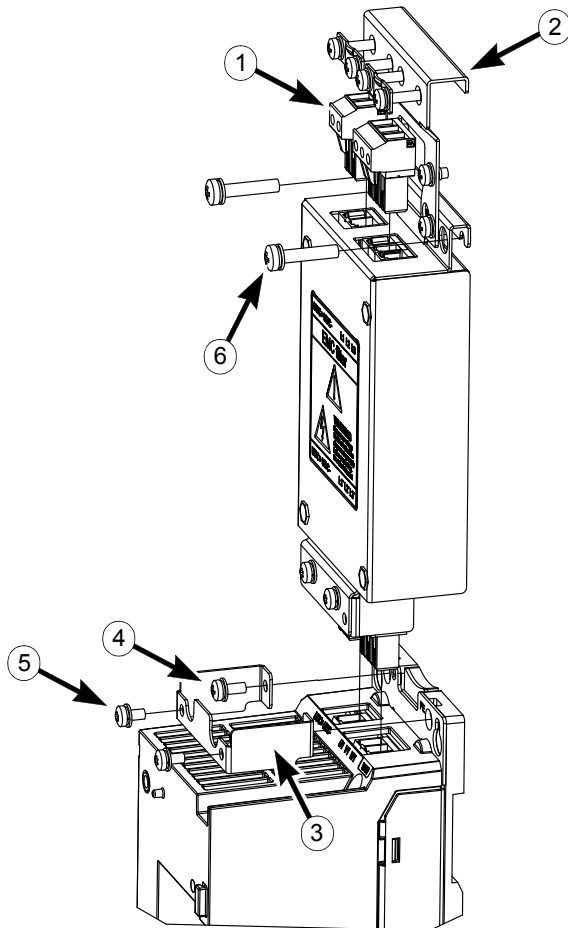

JFI-B1

- Remove the UDC+/- and U1/V1/W1 terminal blocks (1), and the upper power cable clamp plate (2) from the drive.
- Push the filter into the connectors.
- Fasten the filter to the drive module base with two screws (3). Tighten to 1.5 N·m (13 lbf·in).
- Fasten the top edge of the filter to the mounting base with two screws (4).
- Fasten the power cable clamp plate at the top of the filter. Tighten to 1.5 N·m (13 lbf·in).
- Attach the terminal blocks to the filter.

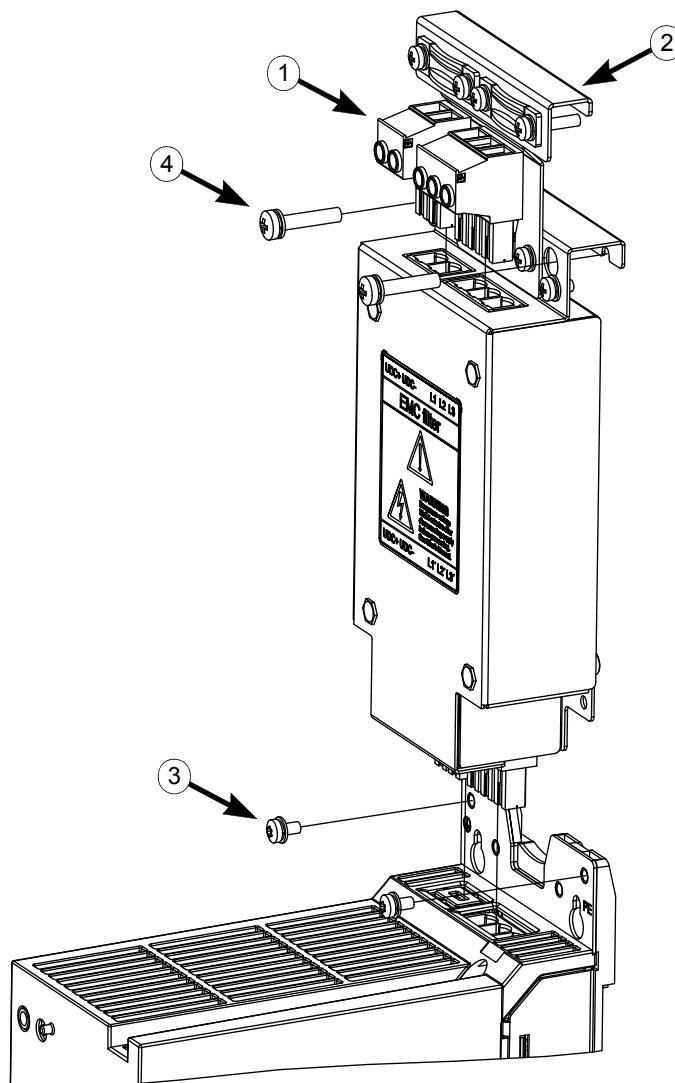

JFI-0x (Frames A...D, category C2) installation

Installation guidelines

- If a mains choke is also installed, the EMC filter is connected between the mains choke and the drive module.
- For optimal operation of the filter, the drive and the filter must be mounted on the same conductive surface.
- Ensure the filter does not block the airflow through the drive module.
- Keep the cable between the drive and the filter as short as possible.

Connection diagram

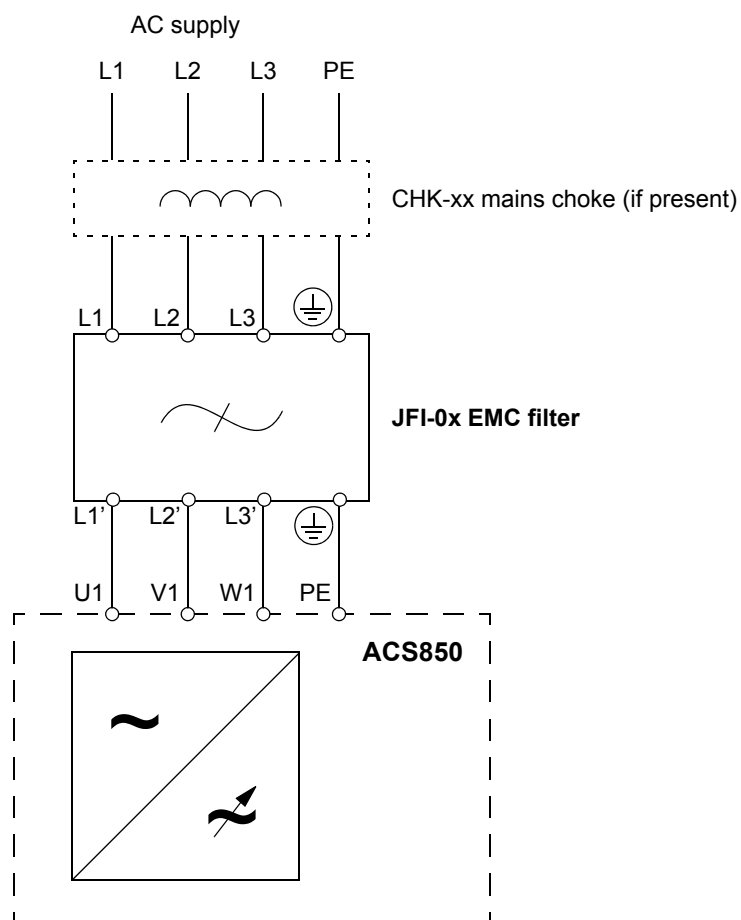

***du/dt* and common mode filtering**

What this chapter contains

This chapter describes how to select *du/dt* and common mode filtering for the ACS850-04. The chapter also contains the relevant technical data.

When is *du/dt* or common mode filtering required?

The output of the drive comprises – regardless of output frequency – pulses of approximately 1.35 times the equivalent supply voltage with a very short rise time. This is the case with all drives employing modern IGBT inverter technology.

The voltage of the pulses can be almost double at the motor terminals, depending on the attenuation and reflection properties of the motor cable and the terminals. This in turn can cause additional stress on the motor and motor cable insulation.

Modern variable speed drives with their fast-rising voltage pulses and high switching frequencies can generate current pulses that flow through the motor bearings, which can gradually erode the bearing races and rolling elements.

The stress on motor insulation can be avoided by using optional ABB *du/dt* filters. *du/dt* filters also reduce bearing currents. Common mode filtering mainly reduces bearing currents.

To avoid damage to the motor bearings, the cables must be selected and installed according to the instructions given in chapter [Electrical installation](#). In addition, *du/dt* filtering, common mode filtering, and insulated N-end bearings must be used according to the following table.

Motor type	Supply voltage (U_N)	Motor insulation system	Requirement		
			du/dt filtering	Insulated N-end bearing	Common mode filtering
Random-wound ABB M2_, M3_ motors	$U_N \leq 500$ V	Any	–	–	–
Form-wound ABB HX_ or modular motor manufactured before 1 Jan 1998	$U_N \leq 500$ V	Any	Check with motor manufacturer	Yes	Yes
Random-wound ABB HX_ and AM_ motor manufactured before 1 Jan 1998	$U_N \leq 500$ V	Enamelled wire with fiberglass taping	Check with motor manufacturer		
Random-wound ABB HX_ and AM_ motor manufactured from 1 Jan 1998	$U_N \leq 500$ V	Enamelled wire with fiberglass taping	–	Yes	Yes
Other ABB motors, or random-wound or form-wound non-ABB motors	$U_N \leq 420$ V	Standard ($\dot{U}_{LL} = 1300$ V)	–	–	–
	420 V < $U_N \leq 500$ V	Standard ($\dot{U}_{LL} = 1300$ V)	Yes	–	–
		Reinforced ($\dot{U}_{LL} = 1600$ V, 0.2 microsecond rise time)	–	–	–

du/dt filters are optional accessories and to be ordered separately. For more information on common mode filtering, contact your local ABB representative. Contact the motor manufacturer for information on the motor construction.

Filter types

du/dt filters

<i>du/dt filters for ACS850-04</i>	
Drive type ACS850-04...	Filter type
-03A0-2, -03A0-5	NOCH0016-60 (3-phase)
-03A6-2, -03A6-5	
-04A8-2, -04A8-5	
-06A0-2, -06A0-5	
-08A0-2, -08A0-5	
-010A-2, -010A-5	
-014A-2, -014A-5	
-018A-2, -018A-5	
-025A-2, -025A-5	NOCH0030-60 (3-phase)
-030A-2, -030A-5	
-035A2, -035A-5	
-044A-2, -044A-5	NOCH0070-60 (3-phase)
-050A-2, -050A-5	
-061A-2, -061A-5	
-078A-2, -078A-5	
-094A-2, -094A-5	NOCH0120-60 (1-phase; three filters included in kit)

Common mode filters

Contact your local ABB representative.

Technical data**du/dt filters***Dimensions and weights*

Filter type	Height mm (inches)	Width mm (inches)	Depth mm (inches)	Weight kg (lbs)
NOCH0016-60	195 (7.68)	140 (5.51)	115 (4.53)	2.4 (5.3)
NOCH0030-60	215 (8.46)	165 (6.50)	130 (5.12)	4.7 (10.4)
NOCH0070-60	261 (10.28)	180 (7.09)	150 (5.91)	9.5 (20.9)
NOCH0120-60*	200 (7.87)	154 (6.06)	106 (4.17)	7.0 (15.4)

*Dimensions given are per phase

Degree of protection

IP00

Common mode filters

Contact your local ABB representative.

Installation

Follow the instructions included with the filters.

Resistor braking

What this chapter contains

This chapter describes how to select, protect and wire braking choppers and resistors. The chapter also contains the technical data.

Braking choppers and resistors with the ACS850-04

Braking choppers

ACS850-04 (frame A...D) drives have a built-in braking chopper as standard equipment to handle the energy generated by a decelerating motor.

When the braking chopper is enabled and a resistor connected, the chopper will start conducting when the DC link voltage of the drive reaches $U_{DC_BR} - 30$ V. The maximum braking power is achieved at $U_{DC_BR} + 30$ V.

$$U_{DC} = 1.35 \times \text{Used AC supply voltage}$$

$$U_{DC_BR} = 1.25 \times U_{DC}$$

Braking resistor selection

To select a braking resistor:

1. Calculate the maximum power generated by the motor during braking.
2. Calculate the continuous power based on the braking duty cycle.
3. Calculate the braking energy during the duty cycle.

Pre-selected resistors are available from ABB as shown in the table on page [111](#). If the listed resistor is not sufficient for the application, a custom resistor can be selected within the limits imposed by the internal braking chopper of the ACS850-04. The following rules apply:

- The resistance of the custom resistor must be at least R_{min} . The braking power capacity with different resistance values can be calculated from the following formula:

$$P_{max} < \frac{U_{DC_BR} + 30 \text{ V}^2}{R}$$



WARNING! Never use a braking resistor with a resistance below the value specified for the particular drive type. The drive and the chopper are not able to handle the overcurrent caused by the low resistance.

- The maximum braking power must not exceed P_{brmax} at any point
- The average braking power must not exceed P_{brcont}
- The braking energy must not exceed the energy dissipation capacity of the selected resistor
- It is highly recommended that the resistor be protected from thermal overload; see section [Contactor protection of drive](#) on page 112.

Chopper data table

The ratings apply at an ambient temperature of 40°C (104°F).

Drive type ACS850-04...	Internal braking chopper							P_{brmax} (kW)	R_{min} (ohm)
	P_{br5} (kW)	P_{br5} (kW) L	P_{br10} (kW)	P_{br10} (kW) L	P_{brcont} (kW)	P_{brcont} (kW) L			
-03A0-2	0.5	0.2	0.5	0.2	0.45	0.15	2.75	120	
-03A6-2	0.75	0.3	0.7	0.25	0.65	0.2			
-04A8-2	1.0	0.3	1.0	0.3	0.9	0.25			
-06A0-2	1.5	0.8	1.4	0.75	1.3	0.35			
-08A0-2									
-010A-2	2.8	1.0	2.7	0.9	2.25	0.75	4.0	80	
-014A-2	4.1	1.3	3.9	1.2	3.3	1.1	7.3	40	
-018A-2	5.3	1.7	5.1	1.6	4.25	1.4			
-025A-2	6.8	3.8	6.5	3.4	5.25	2.7	15.4	20	
-030A-2	7.8	4.4	7.4	4.0	6	3.1			
-035A-2									
-044A-2									
-050A-2	11.4	6.4	10.8	5.7	8.75	4.5	22.0	13	
-061A-2	20.2	14.0	20.0	11.8	18	8			
-078A-2									
-094A-2									
-03A0-5	1.0	0.4	1.0	0.4	0.9	0.3	5.5	120	
-03A6-5	1.5	0.5	1.4	0.5	1.3	0.4			
-04A8-5	2.0	0.6	1.9	0.6	1.8	0.5			
-06A0-5	3.0	1.6	2.8	1.5	2.6	0.7			
-08A0-5									
-010A-5	5.5	1.9	5.3	1.8	4.5	1.5	7.9	80	
-014A-5	8.2	2.6	7.8	2.4	6.6	2.1	14.6	40	
-018A-5	10.5	3.4	10.1	3.2	8.5	2.7			
-025A-5	13.6	7.6	12.9	6.8	10.5	5.4	30.7	20	
-030A-5	15.5	8.8	14.7	7.9	12	6.2			
-035A-5									
-044A-5	22.7	12.7	21.5	11.4	17.5	9	43.9	13	
-050A-5									
-061A-5	40.4	28.0	40.0	23.6	36	16			
-078A-5									
-094A-5									

581898

- L Low motor noise mode. See section [Low motor noise derating](#) on page 80.
- P_{br5} The drive (inverter and chopper) will withstand this braking power for 5 seconds per minute.
- P_{br10} The drive (inverter and chopper) will withstand this braking power for 10 seconds per minute.

- P_{brcont} The drive (inverter and chopper) will withstand this continuous braking power. The braking is considered continuous if the braking time exceeds 30 seconds.
- P_{brmax} Maximum braking power of the drive (inverter and chopper). The drive (inverter and chopper) will withstand this braking power for 1 second within every 10 seconds. **Note:** The listed resistors will withstand this braking power for 1 second within every 120 seconds.
- R_{min} The minimum allowed resistance of the braking resistor.

Resistor selection table

The ratings apply at an ambient temperature of 40°C (104°F).

Drive type ACS850-04...	Example braking resistor			
	Type	R (ohm)	P_n (W)	E_{pulse} (kJ)
-03A0-2, -03A0-5	JBR-01	120	105	22
-03A6-2, -03A6-5				
-04A8-2, -04A8-5				
-06A0-2, -06A0-5				
-08A0-2, -08A0-5				
-010A-2, -010A-5	JBR-03	80	135	40
-014A-2, -014A-5	JBR-04	40	360	73
-018A-2, -018A-5				
-025A-2, -025A-5	JBR-05	20	570	77
-030A-2, -030A-5				
-035A-2, -035A-5				
-044A-2, -044A-5				
-050A-2, -050A-5	JBR-06	13	790	132
-061A-2, -061A-5				
-078A-2, -078A-5				
-094A-2, -094A-5				

581898

- R Resistance of the listed resistor.
- P_n Continuous power (heat) dissipation of the listed resistor when cooled naturally in a vertical position.
- E_{pulse} Energy pulse the listed resistor will withstand.

The braking resistors are protected to IP20. Refer to page [123](#) for dimensions, wire sizes and tightening torques for the resistors

Resistor installation and wiring

All resistors must be installed outside the drive module in a place where they are cooled sufficiently, do not block the airflow to other equipment, or dissipate hot air into the air inlets of other equipment.



WARNING! The materials near the braking resistor must be non-flammable. The surface temperature of the resistor may rise above 200 °C (400 °F), and the temperature of the air flowing from the resistor is hundreds of degrees Celsius. Protect the resistor against contact.

The maximum length of the resistor cable(s) is 20 m (65 ft). For the connections, see section [Power cable connection](#) on page [52](#).

Contactor protection of drive

It is highly recommended to equip the drive with a main contactor for safety reasons. Wire the contactor so that it opens in case the resistor overheats. This is essential for safety since the drive will not otherwise be able to interrupt the main supply if the chopper remains conductive in a fault situation.

Below is a simple example wiring diagram.

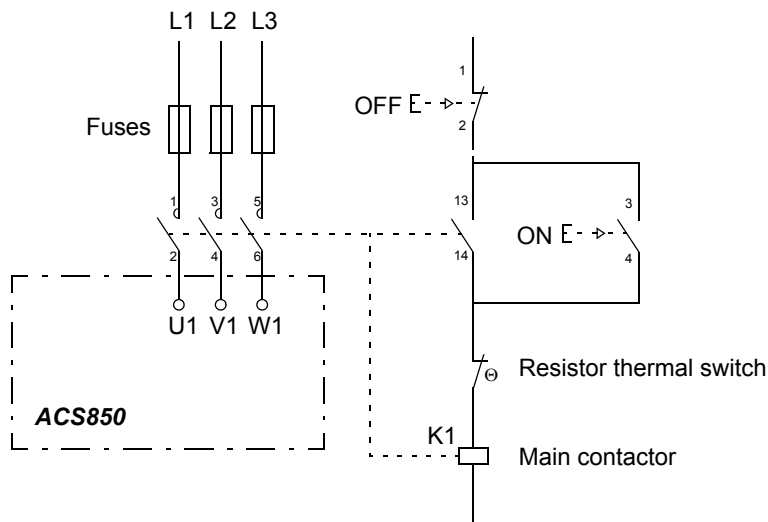

Braking circuit commissioning

For more information, see the appropriate *Firmware Manual*.

- Enable the braking chopper function. Please note that a braking resistor must be connected when the chopper is enabled
- Switch off the overvoltage control of the drive
- Adjust any other relevant parameters in group 48.



WARNING! If the drive is equipped with a braking chopper but the chopper is not enabled by parameter setting, the braking resistor must be disconnected because the protection against resistor overheating is then not in use.

Dimension drawings

What this chapter contains

Dimension drawings of the ACS850-04 and related accessories are shown below. The dimensions are given in millimetres and [inches].

Frame size A

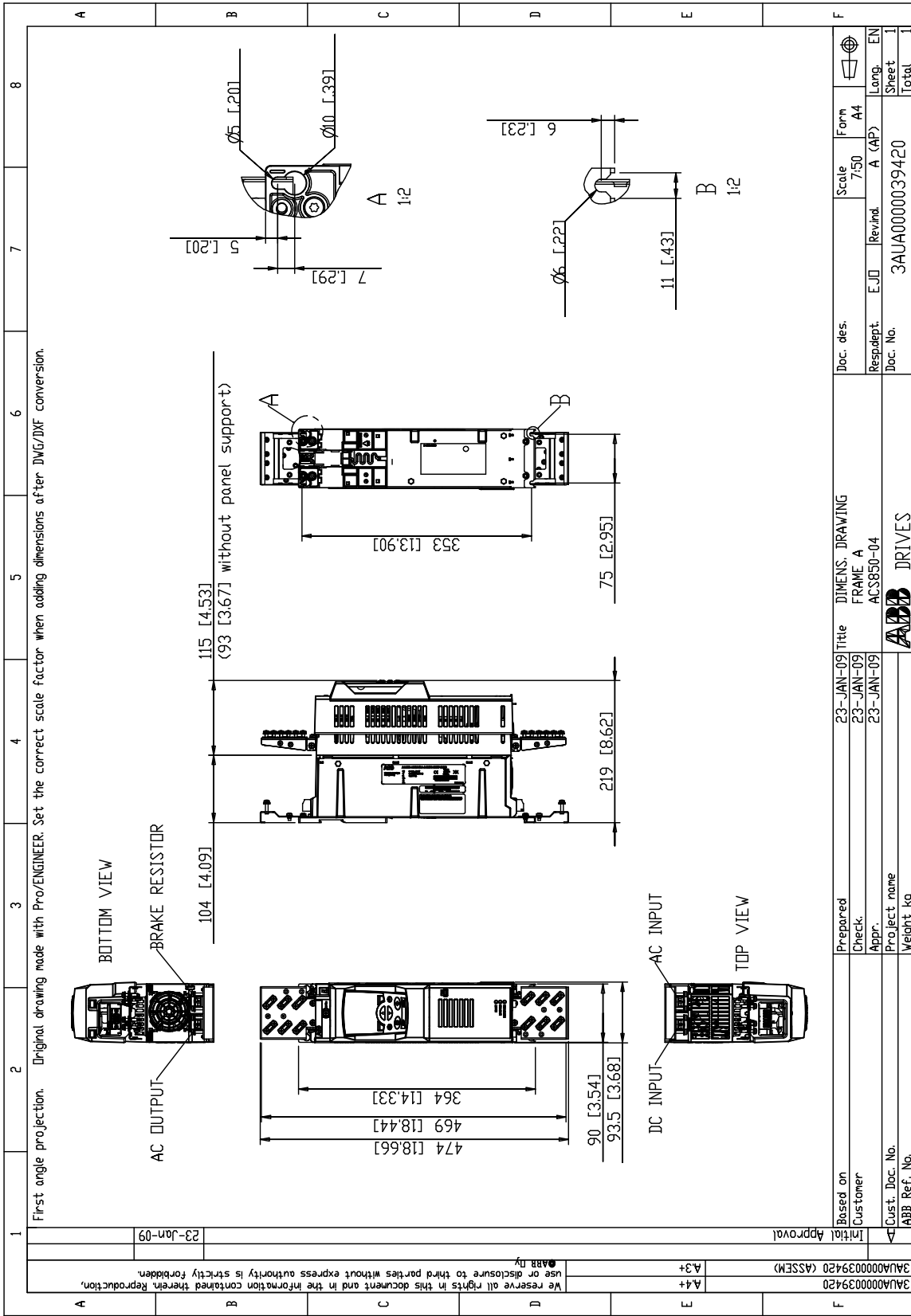

Frame size C

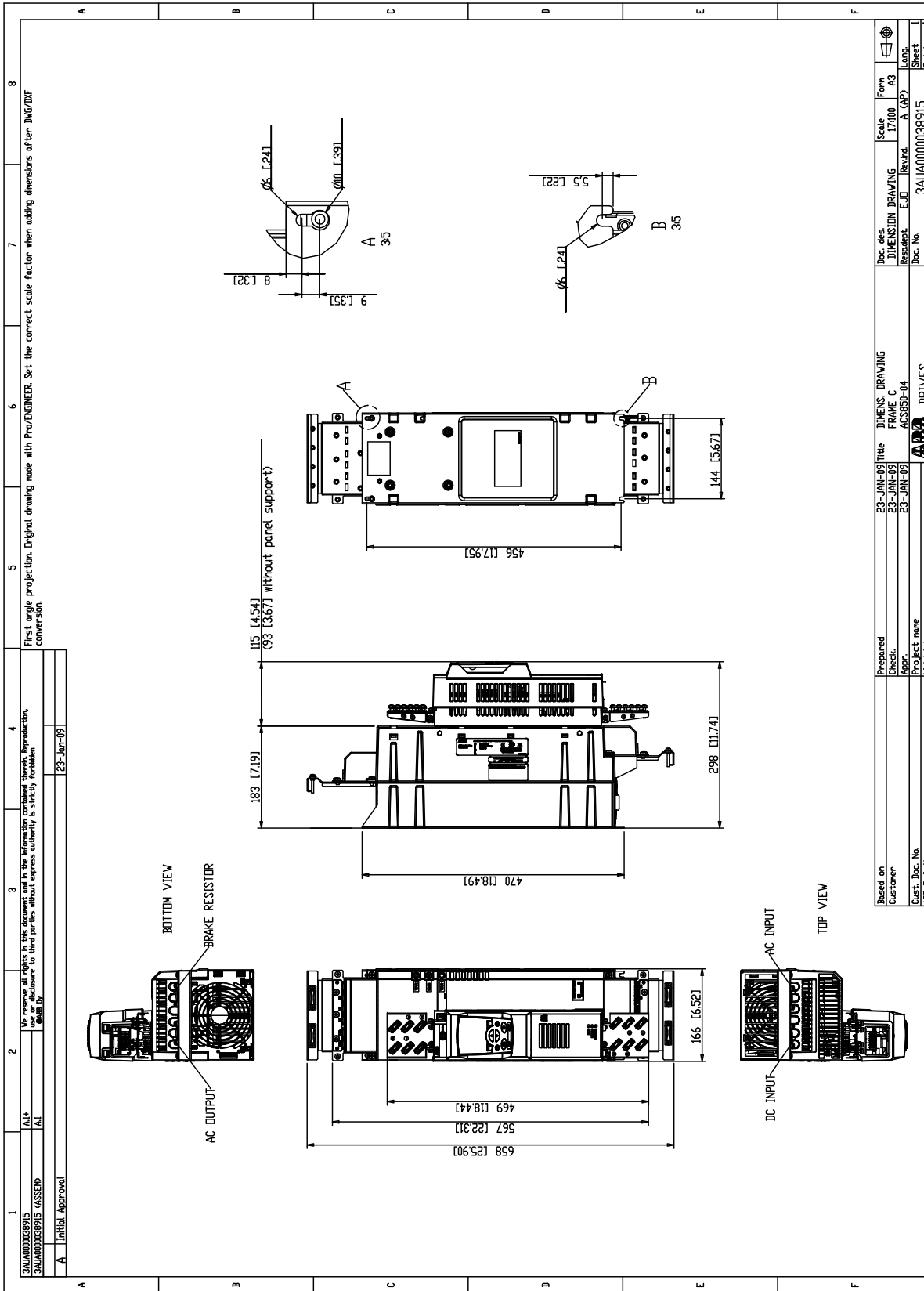

First angle projection. Original drawing made with Pro/ENGINEER. Set the correct scale factor when adding dimensions after IMG/DWG conversion.

1	2	3	4	5	6	7	8
3AUJ000038915	3AUJ000038915	3AUJ000038915	3AUJ000038915	3AUJ000038915	3AUJ000038915	3AUJ000038915	3AUJ000038915
Initial Approval							
Prepared Checked Appr. Project name Weight kg		DIMENS. DRAWING FRAME C ACS550-04		DIMENS. DRAWING SCALE 1:1 A3		Form A3	
Customer 3AUJ000038915		Date 23-JAN-19		Respondent E.J. Revind		Loop A (AP)	
ABB Ref. No. 3AUJ000038915		Project name DRIVES		Doc. No. 3AUJ000038915		Sheet 1	
						Total 1	

Frame size D

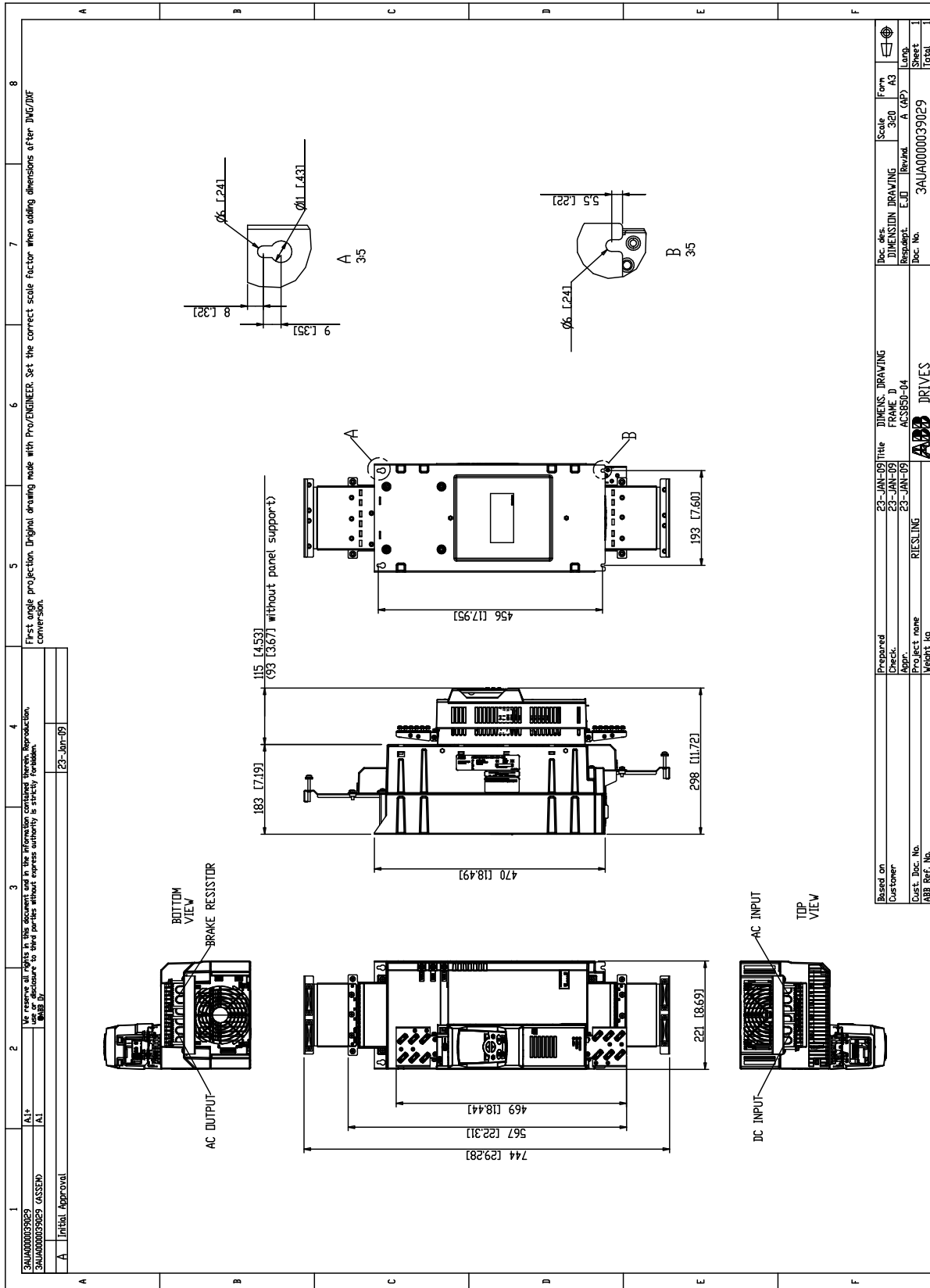

Mains chokes (type CHK-0x)

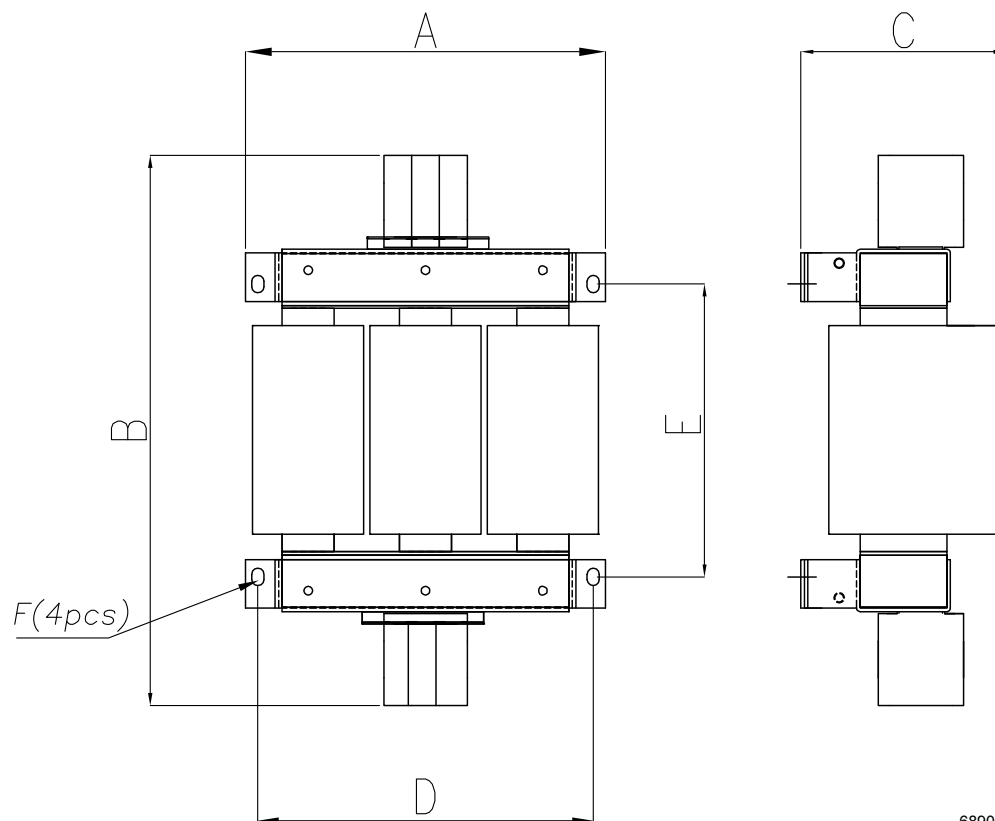

68906903

CHK-xx dimensions				
Parameter	Choke type			
	CHK-01	CHK-02	CHK-03	CHK-04
dim A mm (in.)	120 (4.72)	150 (5.91)	150 (5.91)	150 (5.91)
dim B mm (in.)	146 (5.75)	175 (6.89)	175 (6.89)	175 (6.89)
dim C mm (in.)	79 (3.11)	86 (3.39)	100 (3.94)	100 (3.94)
dim D mm (in.)	77 (3.03)	105 (4.13)	105 (4.13)	105 (4.13)
dim E mm (in.)	114 (4.49)	148 (5.83)	148 (5.83)	148 (5.83)
F screw size	M5	M5	M5	M5
Weight kg (lbs)	1.8 (4.0)	3.8 (8.4)	5.4 (11.9)	5.2 (11.5)
Wire size – Main terminals mm ² (AWG)	0.5 ... 10 (20...6)	0.5 ... 10 (20...6)	0.5 ... 10 (20...6)	0.5 ... 10 (20...6)
Tightening torque – Main terminals N·m (lbf·in)	1.5 (13)	1.5 (13)	1.5 (13)	1.5 (13)
PE/Chassis terminals	M4	M5	M5	M5
Tightening torque – PE/Chassis terminals N·m (lbf·in)	3 (26)	4 (35)	4 (35)	4 (35)

EMC filters (type JFI-x1)

JFI-A1

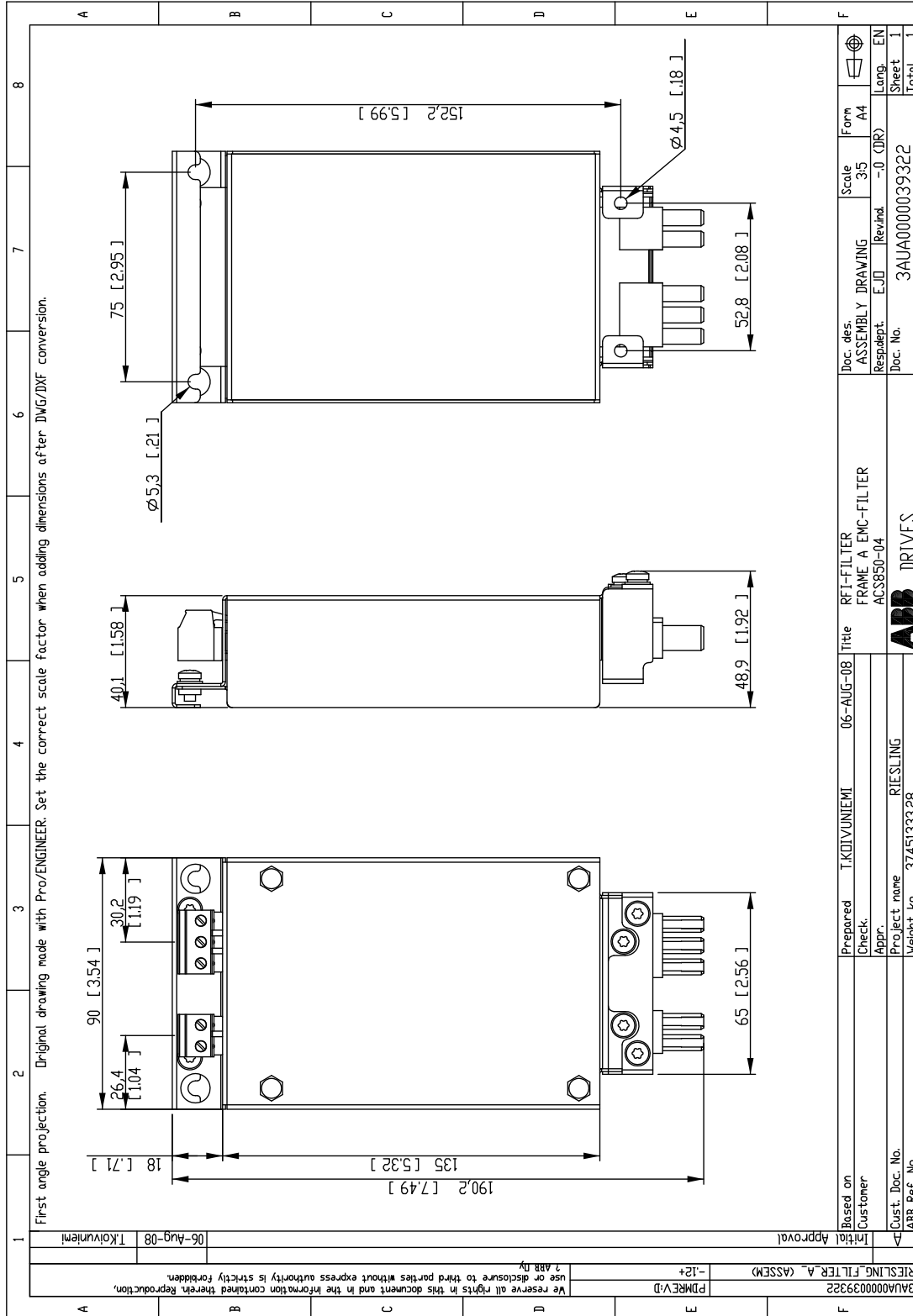

JFI-B1

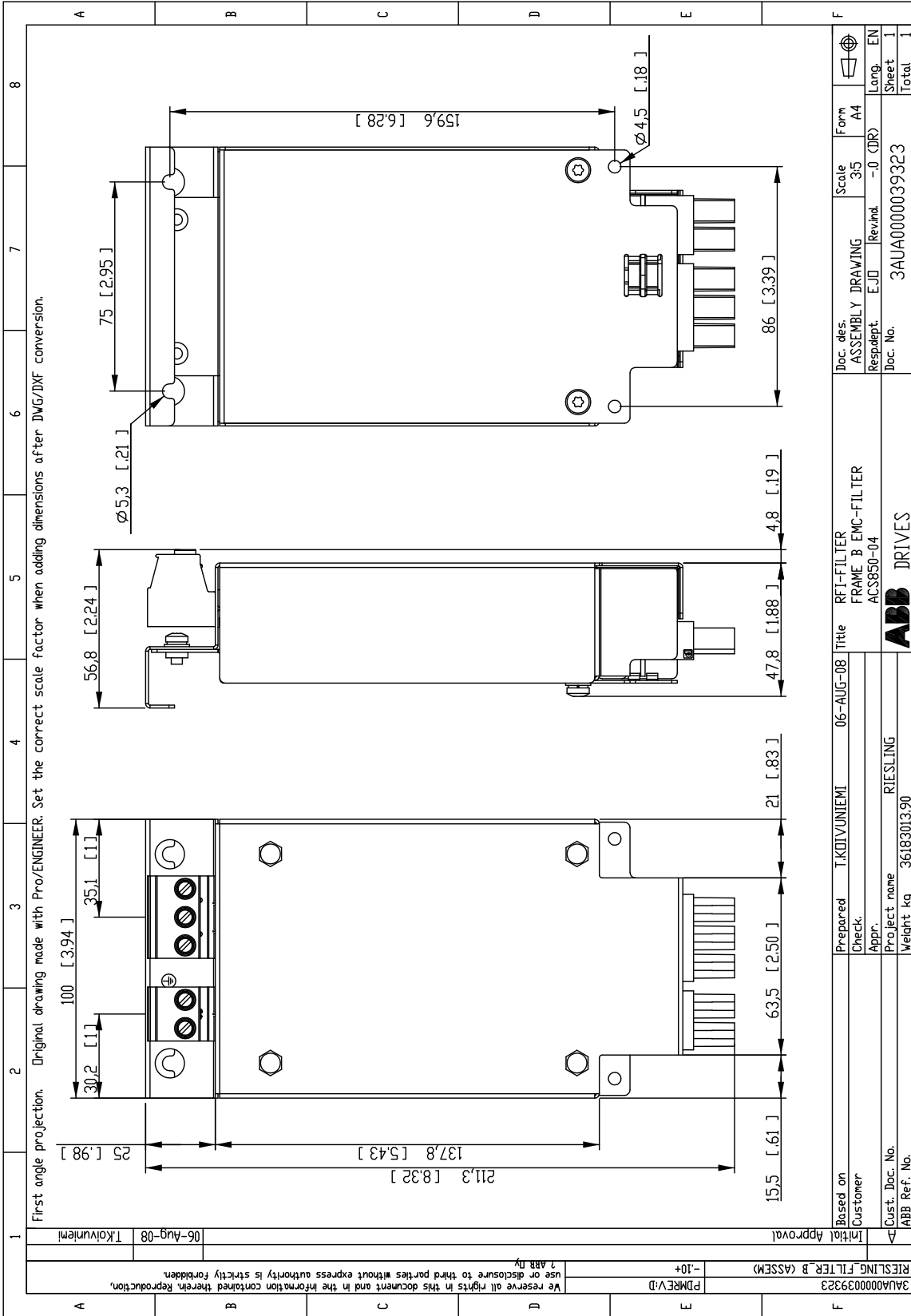

Parameter	JFI-xx dimensions		
	JFI-02	JFI-03	JFI-05
Dim. A mm (in.)	250 (9.84)	250 (9.84)	250 (9.84)
Dim. B mm (in.)	45 (1.77)	50 (1.97)	85 (3.35)
Dim. C mm (in.)	70 (2.76)	85 (3.35)	90 (3.54)
Dim. D mm (in.)	220 (8.66)	240 (9.45)	220 (8.66)
Dim. E mm (in.)	235 (9.25)	255 (10.04)	235 (9.25)
Dim. F mm (in.)	25 (0.98)	30 (1.18)	60 (2.36)
Dim. G mm (in.)	5.4 (0.21)	5.4 (0.21)	5.4 (0.21)
Dim. H mm (in.)	1 (0.04)	1 (0.04)	1 (0.04)
Dim. I mm (in.)	22 (0.87)	25 (0.98)	39 (1.54)
Dim. J	M5	M5	M6
Dim. K mm (in.)	22.5 (0.89)	25 (0.98)	42.5 (1.67)
Dim. L mm (in.)	29.5 (1.16)	39.5 (1.56)	26.5 (1.04)
Weight kg (lbs)	0.8 (1.75)	1.1 (2.4)	1.8 (4.0)
Wire size (solid) mm ² (AWG)	0.2 ... 10 (AWG24...8)	0.5 ... 16 (AWG20...6)	6...35 (AWG8...2)
Wire size (stranded) mm ² (AWG)	0.2 ... 6 (AWG24...10)	0.5 ... 10 (AWG20...8)	10...25 (AWG6...4)
Tightening torque of terminals N·m (lbf·in)	1.5 ... 1.8 (13.3 ... 15.9)	1.5 ... 1.8 (13.3 ... 15.9)	4.0 ... 4.5 (35 ... 40)
			7...8 (60...70)

Braking resistors (type JBR-xx)

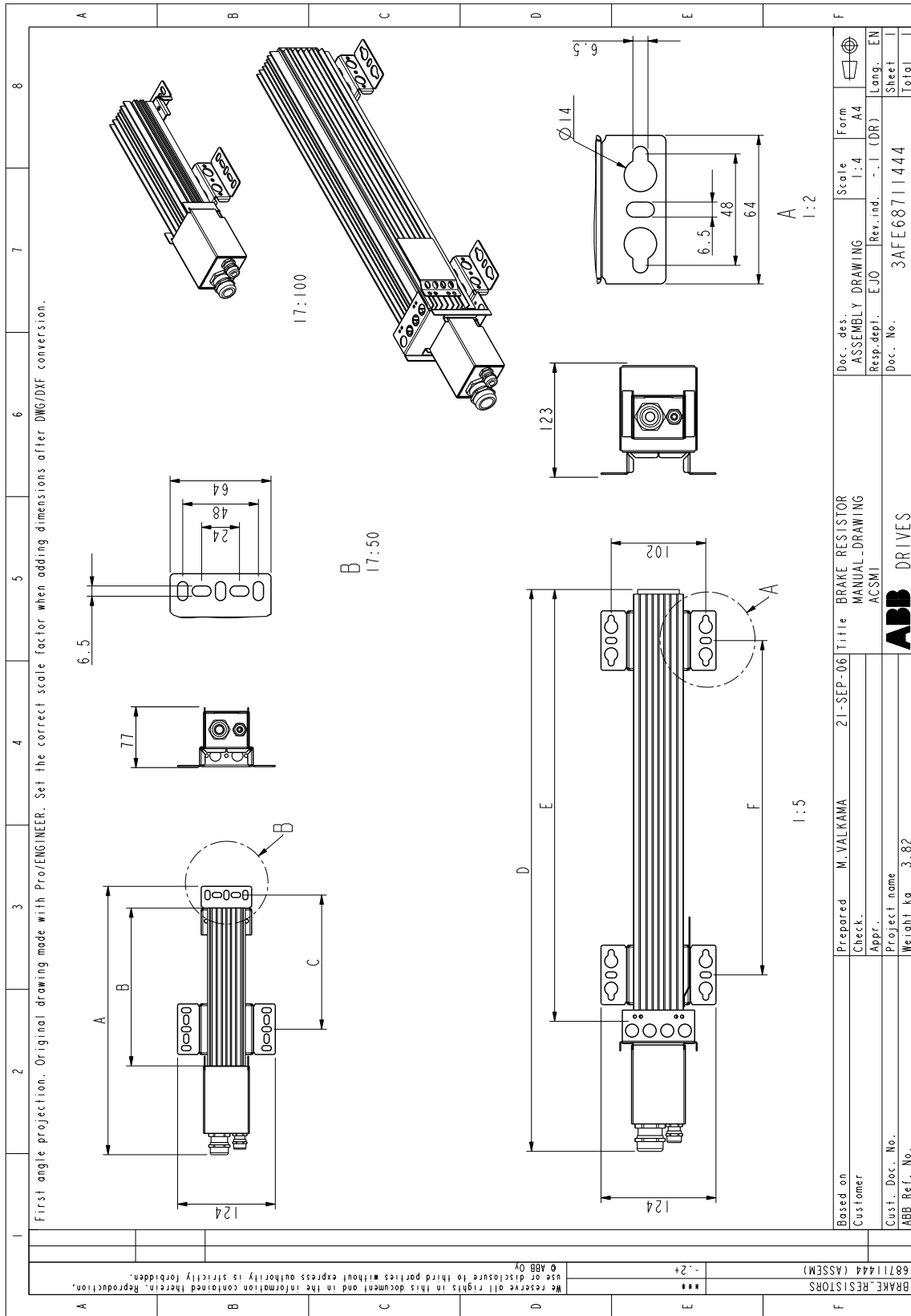

JBR-xx dimensions						
Parameter	Resistor type					
	JBR-01	JBR-03	JBR-04	JBR-05	JBR-06	
Dim. A mm (in.)	295 (11.61)	340 (13.39)	–	–	–	–
Dim. B mm (in.)	155 (6.10)	200 (7.87)	–	–	–	–
Dim. C mm (in.)	125 (4.92)	170 (6.69)	–	–	–	–
Dim. D mm (in.)	–	–	345 (13.58)	465 (18.31)	595 (23.43)	–
Dim. E mm (in.)	–	–	210 (8.27)	330 (12.99)	460 (18.11)	–
Dim. F mm (in.)	–	–	110 (4.33)	230 (9.06)	360 (14.17)	–
Weight kg (lbs)	0.75 (1.7)	0.8 (1.8)	1.8 (4.0)	3.0 (6.6)	3.9 (8.6)	–
Max. wire size – Main terminals	10 mm ² (AWG6)					
Tightening torque – Main terminals	1.5 ... 1.8 N·m (13 ... 16 lbf·in)					
Max. wire size – Thermal switch terminals	4 mm ² (AWG12)					
Tightening torque – Thermal switch terminals	0.6 ... 0.8 N·m (5.3 ... 7.1 lbf·in)					

Further information

Product and service inquiries

Address any inquiries about the product to your local ABB representative, quoting the type designation and serial number of the unit in question. A listing of ABB sales, support and service contacts can be found by navigating to www.abb.com/drives and selecting *Sales, Support and Service network*.

Product training

For information on ABB product training, navigate to www.abb.com/drives and select *Training courses*.

Providing feedback on ABB Drives manuals

Your comments on our manuals are welcome. Go to www.abb.com/drives and select *Document Library – Manuals feedback form (LV AC drives)*.

Document library on the Internet

You can find manuals and other product documents in PDF format on the Internet. Go to www.abb.com/drives and select *Document Library*. You can browse the library or enter selection criteria, for example a document code, in the search field.



ABB Oy

Drives
P.O. Box 184
FI-00381 HELSINKI
FINLAND
Telephone +358 10 22 11
Fax +358 10 22 22681
www.abb.com/drives

ABB Inc.

Automation Technologies
Drives & Motors
16250 West Glendale Drive
New Berlin, WI 53151
USA
Telephone 262 785-3200
1-800-HELP-365
Fax 262 780-5135
www.abb.com/drives

ABB Beijing Drive Systems Co. Ltd.

No. 1, Block D, A-10 Jiuxianqiao Beilu
Chaoyang District
Beijing, P.R. China, 100015
Telephone +86 10 5821 7788
Fax +86 10 5821 7618
www.abb.com/drives

3AUA0000045496 Rev E / EN
EFFECTIVE: 2010-10-26