

ABB Drives

[efesotomasyon.com](http://efesotomasyon.com)

---

**Installation and Start-up Guide**

[efesotomasyon.com](http://efesotomasyon.com)

---

CS 31 Adapter Module  
NCSA-01





CS 31 Adapter Module  
NCSA-01

**Installation and  
Start-up Guide**

[efesotomasyon.com](http://efesotomasyon.com)

---

3BFE 58920029 R0225

EFFECTIVE: 1.12.1999  
SUPERSEDES: 1996-02-01



# Safety Instructions

---

## Overview

This chapter states the safety instructions that must be followed when installing and operating the NCSA-01 CS 31 Adapter Module. The material in this chapter must be studied before attempting any work on, or with, the unit.

## Warnings and Notes

This manual distinguishes two sorts of safety instructions. Warnings are used to inform of conditions which can, if proper steps are not taken, lead to a serious fault condition, physical injury and death. Notes are used when the reader is required to pay special attention or when there is additional information available on the subject. Notes are less crucial than Warnings, but should not be disregarded.

### Warnings

Readers are informed of situations that can result in serious physical injury and/or serious damage to equipment with the following symbols:



**Dangerous Voltage Warning:** warns of situations in which a high voltage can cause physical injury and/or damage equipment. The text next to this symbol describes ways to avoid the danger.



**General Warning:** warns of situations which can cause physical injury and/or damage equipment by means other than electrical. The text next to this symbol describes ways to avoid the danger.



**Electrostatic Discharge Warning:** warns of situations in which an electrostatic discharge can damage equipment. The text next to this symbol describes ways to avoid the danger.

### Notes

Readers are notified of the need for special attention or additional information available on the subject with the following symbols:

#### CAUTION!

**Caution** aims to draw special attention to a particular issue.

#### Note:

**Note** gives additional information or points out more information available on the subject.

**General Safety Instructions**



**WARNING!** All electrical installation and maintenance work on the drive should be carried out by qualified electricians.

The drive and adjoining equipment must be properly earthed.

Do not attempt any work on a powered drive. After switching off the mains, always allow the intermediate circuit capacitors 5 minutes to discharge before working on the frequency converter, the motor or the motor cable. It is good practice to check (with a voltage indicating instrument) that the drive is in fact discharged before beginning work.

The motor cable terminals of the drive are at a dangerously high voltage when mains power is applied, regardless of motor operation.

There can be dangerous voltages inside the drive from external control circuits even when the drive mains power is shut off. Exercise appropriate care when working with the unit. Neglecting these instructions can cause physical injury and death.



---

**WARNING!** There are several automatic reset functions in the drive. If selected, they reset the unit and resume operation after a fault. These functions should not be selected if other equipment is not compatible with this kind of operation, or dangerous situations can be caused by such action.

---

More Warnings and Notes are printed at appropriate instances along the text.

# Table of Contents

---

## **Safety Instructions**

Overview .....	i
Warnings and Notes .....	i
Warnings .....	i
Notes .....	i
General Safety Instructions .....	ii

## **Table of Contents**

### **Chapter 1 – Introduction**

Contents .....	1-1
Intended Audience .....	1-1
What This Guide Contains .....	1-1
Conventions Used in This Guide .....	1-2

### **Chapter 2 – Overview**

Contents .....	2-1
CS 31 .....	2-1
NCSA-01 .....	2-1
Compatibility .....	2-2
Delivery Check .....	2-3
Warranty and Liability Information .....	2-3

### **Chapter 3 – Mechanical Installation**

Contents .....	3-1
Mounting Outside the Drive .....	3-1
Mounting Inside the Drive .....	3-2

### **Chapter 4 – Electrical Installation**

Contents .....	4-1
Cabling .....	4-1
Bus Termination .....	4-1
NCSA-01 Connections .....	4-2
Earthing .....	4-3
Earthing the Bus Cable Screens .....	4-3

## Table of Contents

### **Chapter 5 – Programming**

Contents . . . . .	5-1
Configuring the System . . . . .	5-1
Drive Configuration . . . . .	5-1
Control Locations. . . . .	5-4

### **Chapter 6 – Communication**

Contents . . . . .	6-1
CS 31 Messaging . . . . .	6-1
Memory Mapping . . . . .	6-1
Drive Control Data . . . . .	6-2
Drive Feedback Data . . . . .	6-3
The Control Word and the Status Word. . . . .	6-4
References . . . . .	6-4
Actual Values. . . . .	6-4

### **Chapter 7 – Fault Tracing**

Contents . . . . .	7-1
Installation Problems . . . . .	7-1
Drive Setup Problems . . . . .	7-1
PLC Programming Problems . . . . .	7-1
Status LEDs . . . . .	7-2
Normal Power-up Sequence . . . . .	7-2

### **Appendix A – Technical Data**

DDCS Link . . . . .	A-1
Fieldbus Link . . . . .	A-2
NCSA-01 . . . . .	A-3

### **Appendix B – Ambient Conditions**

Ambient Conditions, Operation . . . . .	B-1
Ambient Conditions, Storage . . . . .	B-1
Ambient Conditions, Transportation . . . . .	B-1

# Chapter 1 – Introduction

---

## **Contents**

This chapter contains a description of the *NCSA-01 CS 31 Adapter Module Installation and Start-up Guide*.

## **Intended Audience**

The Guide is intended for the people who are responsible for installing, commissioning, and using the NCSA-01 CS 31 Adapter Module with an ABB drive. The reader is expected to have a basic knowledge of electrical fundamentals, electrical wiring practices, the drive, and the use of the drive control panel.

## **What This Guide Contains**

The installation and start-up of the NCSA-01 CS 31 Adapter Module are introduced in this Guide.

It is assumed that the drive is installed and ready to operate before starting the installation of the adapter module. For more information on the installation and start-up procedures of the drive, please refer to its user documentation.

**Safety Instructions** are featured in the first few pages of this Guide. Safety Instructions describe the formats for various warnings and notations used within this Guide. This chapter also states the safety instructions which apply to the installation and operation of the NCSA-01 Module.

**Chapter 2 – Overview** contains a short description of the CS 31 system and the NCSA-01 Adapter Module, a delivery checklist, and information on the manufacturer's warranty.

**Chapter 3 – Mechanical Installation** contains the instructions for placing and mounting the module.

**Chapter 4 – Electrical Installation** contains the wiring instructions.

**Chapter 5 – Programming** explains how to program the master station and the drive before the communication through the adapter module can be started.

**Chapter 6 – Communication** contains a description of how data is transmitted through the NCSA-01.

**Appendix A** contains technical data.

**Appendix B** contains a specification of the ambient conditions allowed during transportation, storage and use of the NCSA-01.

## **Conventions Used in This Guide**

<i>Communication Module (COMM.MODULE)</i>	Communication Module is a parameter name/parameter selection name for a device (e.g. a fieldbus adapter) through which the drive is connected to an external serial communication network (e.g. a fieldbus). The communication with the communication module is activated with a drive parameter.
<i>Data Sets and Data Words</i>	Data sets are clusters of data sent through the DDCS link between the fieldbus adapter module and the drive. Each data set consists of three 16-bit words, ie. data words. The Control Word (sometimes called the Command Word) and the Status Word, References, and Actual Values (see Chapter 6) are types of data words; the contents of some data words are user-definable.
<i>DDCS</i>	Distributed Drives Communication System; a communication protocol used in fibre optic links in ABB drives.
<i>Parameter</i>	A parameter is an operating instruction for the drive. Parameters can be read and programmed with the drive control panel.

## Chapter 2 – Overview

---

### **Contents**

This chapter contains a short description of the CS 31 bus and the NCSA-01 CS 31 Adapter Module, an option package delivery checklist, and warranty information.

### **CS 31**

ABB Procontic CS 31 is a decentralised automation system. A typical CS 31 system consists of a Central Processing Unit and remote input/output units connected by serial communication bus. Using the CS 31 connection it is possible to handle a large amount of distributed process I/O in one central unit.

The physical transmission medium of the bus is a twisted pair cable (according to RS 485 standard). The maximum length of the bus cable is 500 metres and the transmission rate is 187.5 kbitps.

From the bus administration point of view all the remote units are slave stations. No communication between the slaves is possible. There is one master station – a CS 31 central unit – which polls the slave stations cyclically.

All messages from the master carry an address. The slave (remote unit) with this address receives the message and sends a response message back to the master. The master updates the system image continuously.

For more information on the CS 31 system, refer to Technical Documentation FPTN 440 004 R2001-a, available from ABB Control (France).

### **NCSA-01**

The NCSA-01 CS 31 Adapter Module is an optional device that enables connection of an ABB drive to a CS 31 system. The module is considered as a remote input/output unit in the system. A total of 30 remote units (e.g. NCSA-01 Modules) can be connected to one CS 31 master. (This is an electrical limit as each remote unit weakens the bus signal.) By default, the master writes the reference values to the drive every 6 milliseconds.

Through the NCSA-01, it is possible to

- Give control commands (Start, Stop, Run enable, etc.) to the drive
- Give a motor speed or torque reference to the drive
- Read status information and actual signals from the drive
- Reset a drive fault.

The adapter module can be mounted onto a standard mounting rail inside or outside the drive unit, depending on drive type and

configuration. See the user documentation of the drive for module placement options.

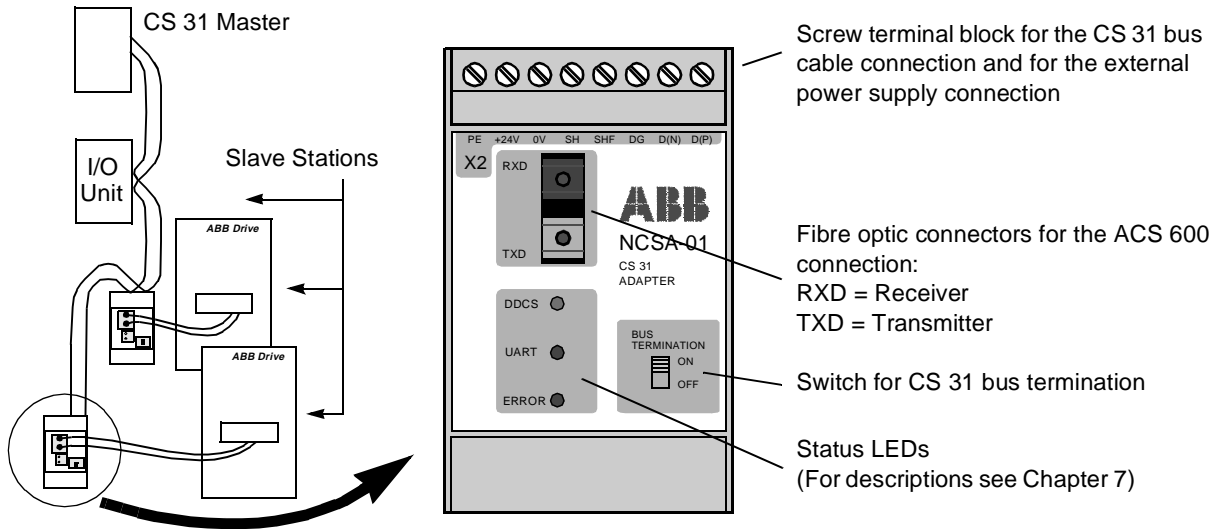

**Compatibility** The NCSA-01 is compatible with the following ABB drives:

- ACS 300 (SW vsn CDD02E.9/CDE02E.9 or later)
- ACS 400
- ACS 600 SingleDrive (SW vsn 2.8 or later)
- ACS 600 MultiDrive
- ACS 600 MotionControl (ACP 600) (SW vsn 1.1 or later)
- ACS 600 CraneDrive (ACC 600)
- ACS 600 Pump and Fan Drive (ACF 600) (SW vsn AF0A1020 or later)
- ACS 1000
- DCS 500 (SW vsn 21.226 or later).

The NCSA-01 is compatible with the following CS 31 master stations:

- Central Processing Units: 07 KR 31, 07 KT 31, 07 KR 91, 07 KT 92, 07 KT 93, AC30
- PLC Couplers: 07 CS 61 and 07 CS 91 for ABB Procontic T200 and T300
- 07 CM 90 PC Board.

- Delivery Check** The NCSA-01 option package contains:
- CS 31 Adapter Module, Type NCSA-01
  - Two pairs (four pieces) of fibre optic cables
  - Mounting rail
  - This manual, the *NCSA-01 Installation and Start-up Guide*.

**Warranty and Liability Information** The warranty for your ABB drive and options covers manufacturing defects. The manufacturer carries no responsibility for damage due to transport or unpacking.

In no event and under no circumstances shall the manufacturer be liable for damages and failures due to misuse, abuse, improper installation, or abnormal conditions of temperature, dust, or corrosives, or failures due to operation above rated capacities. Nor shall the manufacturer ever be liable for consequential and incidental damages.

The period of manufacturer's warranty is 12 months, and not more than 18 months, from the date of delivery.

Extended warranty may be available with certified start-up. Contact your local distributor for details.

Your local ABB Drives company or distributor may have a different warranty period, which is specified in their sales terms, conditions, and warranty terms.

If you have any questions concerning your ABB drive, contact your local distributor or ABB Drives office.

The technical data and specifications are valid at the time of printing. ABB reserves the right to subsequent alterations.



## Chapter 3 – Mechanical Installation

---

### Contents

This chapter contains module mounting instructions. Depending on the drive, the module can be installed either inside or outside the drive housing or cabinet. See the user's manual of the drive for module placement options.

### Mounting Outside the Drive

Choose the location for the module. Note the following:

- The cabling instructions in Chapter 4 must be followed. Also, the length of the fibre optic cables included in the option package restrict the distance between the module and the drive.
- Observe the free space requirements for the module (min. 10 mm from adjoining equipment or wall) and the drive (see the drive documentation).
- The ambient conditions should be taken into account (see Appendix B). The degree of protection of the module is IP 20.
- Module earth is connected to the mounting rail by means of an earthing clip (see figure below). The mounting rail onto which the option module is to be mounted must be earthed to a noiseless earth. If the rail is not mounted on a properly earthed base, a separate earthing conductor must be used. The conductor must be as short as possible and the cross-sectional area must be 6 mm<sup>2</sup> at least. **Note:** No solid copper conductor may be used (stranded wire allowed only).

Mounting instructions:

1. Switch off all dangerous voltages in the enclosure that the module is to be mounted in.
2. Fasten the rail and ensure the proper earthing as described above.
3. Push the module onto the rail. The module can be released by pulling the locking spring with a screwdriver as shown below.

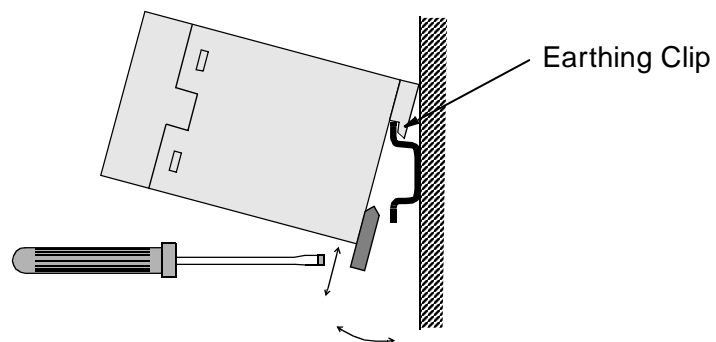

## Mounting Inside the Drive

The work inside the drive should be carried out by a qualified electrician only.



---

**WARNING!** Pay attention to the slowly discharging voltage of the capacitor bank and the voltages that are connected from external control circuits to the inputs and outputs of the drive.

---



---

**WARNING!** Do not touch the printed circuit boards. The integrated circuits are extremely sensitive to electrostatic discharge.

---

Mounting instructions:

1. Stop the drive.
2. Switch off the power supply of the drive and all dangerous voltages connected to the inputs and outputs.
3. Wait for five minutes to ensure that the capacitors in the intermediate circuit have discharged.
4. Remove the front cover of the drive.
5. Ensure that the mains cable, motor cable and capacitor bank (UDC+ and UDC-) are not powered.
6. Locate the position for the module (see the drive documentation). Fasten the mounting rail to its place if not already installed. Observe the free space requirements for the module (min. 10 mm from adjoining equipment/wall).
7. Push the module onto the rail. The module can be released by pulling the locking spring with a screwdriver (see the figure above).

## Chapter 4 – Electrical Installation

### Contents

This chapter contains:

- Cabling instructions
- Instructions for bus termination
- Connection and earthing instructions for the NCSA-01 Module and earthing instructions for the bus cable.



**WARNING!** Before installation, switch off the drive power supply. Wait for five minutes to ensure that the capacitor bank of the drive is discharged. Switch off all dangerous voltages connected from external control circuits to the inputs and outputs of the drive.

### Cabling

Arrange the bus cables as far away from the motor cables as possible. Avoid parallel runs. Use bushings at cable entries.

Handle the fibre optic cables with care. When unplugging optic cables, always grab the connector, not the cable itself. Do not touch the ends of the fibres with bare hands as the fibre is extremely sensitive to dirt.

The maximum long term tensile load for the fibre optic cable is 1 N. The minimum short term bend radius is 25 mm.

### Bus Termination

The built-in terminating resistors must be switched on if the NCSA-01 module is installed at the end of the bus. Otherwise the resistors must be switched off. Terminating resistors prevent signal reflections from the bus cable ends.

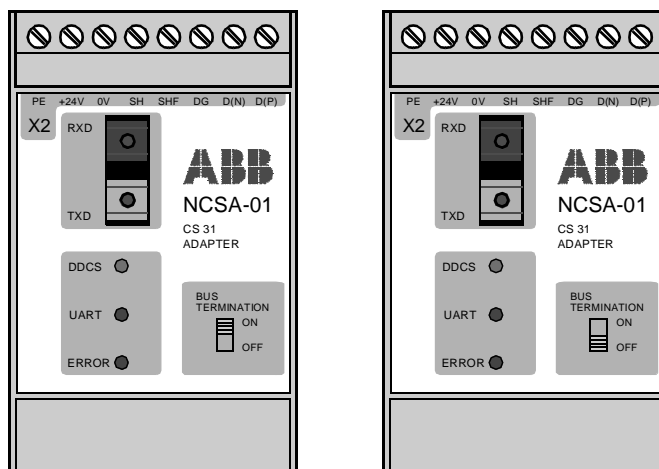

Figure 4-1 Terminating resistors on (left) and off (right).

**NCSA-01 Connections**

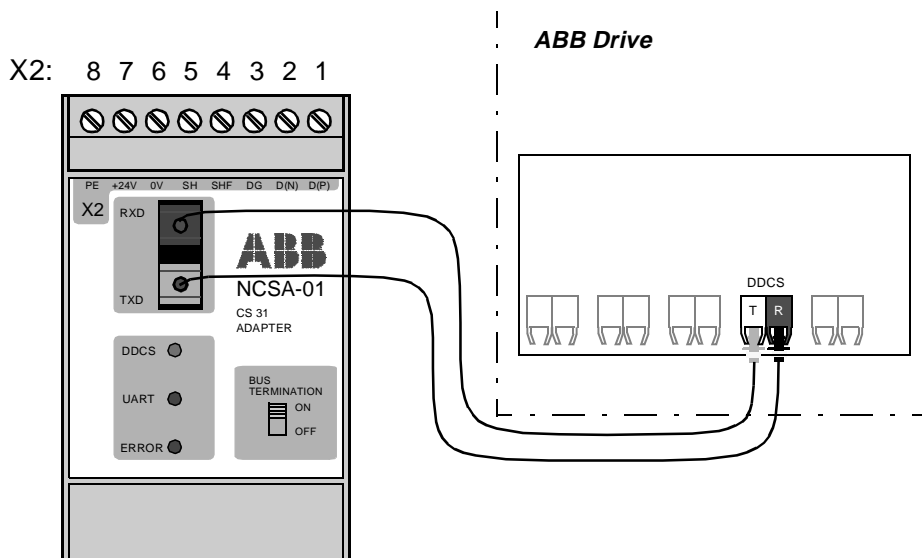

Figure 4-2 Fibre optic link connecting the NCSA-01 adapter to the drive.

The NCSA-01 module is connected to the drive using a fibre optic cable link. Consult the drive documentation as to the corresponding terminals inside the drive.

The bus cable and the external power supply are connected to terminal block X2 on the NCSA-01.

X2		Description
1	D(P)	D(P) = B = Data Positive (Conductor 1 in twisted pair) D(N) = A = Data Negative (Conductor 2 in twisted pair) DG = Data Ground
2	D(N)	
3	DG	
4	SHF	Cable screen AC earthing (via an RC filter)
5	SH	Cable screen earthing (directly earthed)
6	0V	Power supply for the module (24 V d.c. ± 10 %); screened cable.
7	+24 V	
8	PE	Earth

Figure 4-3 Description of terminal block X2.

## Earthing

The NCSA-01 module earth is connected to the rail onto which the module is mounted. If the rail is fastened to an earthed metallic assembly plate, the module is automatically earthed, and no external earthing wire is needed. If the rail is fastened to a base that is not earthed, the rail must be connected to the nearest earthing terminal. However, the earthing wire should not be connected to the same terminal as the power cable screens. (See page 3-1.)

The NCSA-01 module has several built-in earthing terminals (see Figure 4-4):

- The **PE** terminal is internally connected to the NCSA-01 module earth. Normally, no external wires need to be connected to this terminal.
- The **SH** terminal is internally connected to the NCSA-01 module earth. The SH terminal is normally used for earthing the bus cable shield if there is no other station at which the cable shield is directly earthed.
- The **SHF** terminal is internally connected to the NCSA-01 module earth via an RC filter. The SHF terminal is typically used for earthing the bus cable shield.
- The **DG** terminal is isolated from the NCSA-01 module earth. This terminal is to be connected to the SHF terminal on each module (as shown in Figure 4-4 below) in order to provide a common reference potential to all modules on the bus.

### Earthing the Bus Cable Screens

The bus cable screen may be directly earthed at one station only. At other stations the cable screen should be earthed via an RC filter. A wiring example is given below.

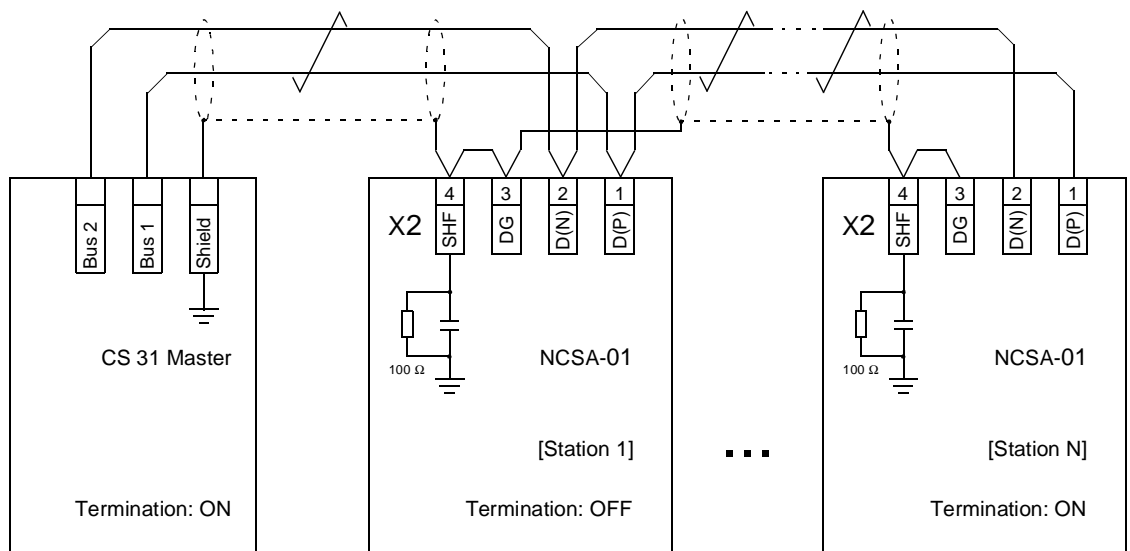

Figure 4-4 CS 31 bus cable connection.



## Chapter 5 – Programming

---

### **Contents**

This chapter gives information on configuring the CS 31 master station and the drive for communication through the NCSA-01 Module.

### **Configuring the System**

After the NCSA-01 Module has been mechanically and electrically installed according to Chapters 3 and 4, the CS 31 master station and the drive must be prepared for communication with the module.

Please refer to the documentation delivered with the master station for information on its configuration.

Type definition programs for various master stations are available from your local ABB representative.

### **Drive Configuration**

The detailed procedure of activating the module for communication with the drive is dependent on drive type. (Normally, a drive parameter must be adjusted to activate the communication. See the drive documentation.)

As communication between the drive and the NCSA-01 is established, several configuration parameters are copied to the drive. These parameters – shown in Figure 5-1 – must be checked first and adjusted if necessary. The alternative selections for these parameters are discussed in more detail below the table. (Note that the new settings take effect only when the module is powered up for the next time.)

---

**Note:** The drive parameter group in which the NCSA-01 configuration parameters appear depends on drive type, as does the adjustment procedure. See the drive documentation for information.

---

NCSA-01 Par. No.*	Parameter Name	Alternative Settings	Default Setting	Remark
01	MODULE TYPE		NCSA-01 Vx.x	Read-only
02	PROTOCOL		<b>(0)</b>	Read-only
03	MODULE ID	<b>(0)</b> WORD; <b>(1)</b> BINARY	<b>(0)</b> WORD	
04	STATION NUMBER	0 ... 5 (Word Mode) 0 ... 57 (Binary Mode)	1	
05	ADDR INDEX	<b>(0)</b> LOWER; <b>(1)</b> UPPER	<b>(0)</b> LOWER	Ineffective in Binary Mode
06	DATA SETS	1; 2; 3	1	
07	DATA SET1 CONST	0 ... 32767 (1 $\Delta$ 6 ms)	1	
08	DATA SET2 CONST	0 ... 32767 (1 $\Delta$ 6 ms)	1	
09	DATA SET3 CONST	0 ... 32767 (1 $\Delta$ 6 ms)	1	
10	DATA SET OFFSET	1 ... 255	1	
*The drive parameter group in which the parameters appear depends on drive type.				

Figure 5-1 Table of NCSA-01 configuration parameters.

**01 MODULE TYPE** This parameter shows the module type as detected by the drive. The value cannot be adjusted by the user. (If this parameter is undefined, the communication between the drive and the module has not been established.)

**02 PROTOCOL** This parameter cannot be adjusted by the user.

**03 MODULE ID** The NCSA-01 module can be used either in *Word Mode* or in *Binary Mode*. For detailed information on selecting the appropriate mode, refer to the CS 31 master station documentation, parameters STATION NUMBER and ADDR INDEX below, and Chapter 6.

**04 STATION NUMBER** Generally, each device on the CS 31 bus must have a unique station number. This parameter is used to define a station number for the drive it is connected to.

In Word Mode, allowable values are 0 to 5. One station number can be shared by two modules in Word Mode. See the ADDR INDEX parameter below.

In Binary Mode, allowable values are 0 to 57. However, consecutive station numbers cannot be used on the same bus. The numbering is also affected by the setting of DATA SETS (see below).

**05 ADDR INDEX** Two NCSA-01 modules can share the same station number, providing that they are both in *Word Mode*, and that this parameter is set to LOWER on one module and to UPPER on the other.

This parameter has no effect in Binary Mode.

**06 DATA SETS** This parameter selects the number of data sets used in CS 31 communication. The default selection (1) denotes that one data set is sent in each direction. Parameter value 2 enables the use of 2 data sets in each direction, and value 3 enables all 3 data sets per direction.

Each data set (abbreviated DS) normally contains three 16-bit data words (DW). However, the overall message length is limited to 16 bytes (8 words) in Word Mode or 15 bytes (7 words) in Binary Mode.

The I/O memory of the CS 31 master is divided between the slaves on the bus. Thus, the number of Binary Mode slaves decreases when the value of this parameter is increased.

The message frame lengths for each parameter value are shown below. The actual contents of the messages and the memory addresses for the data are detailed in Chapter 6.

**06 DATA SETS = 1:**

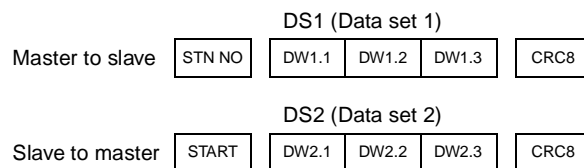

**06 DATA SETS = 2:**

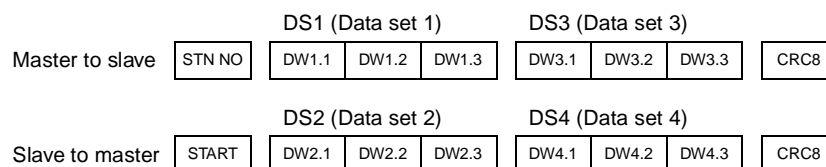

**06 DATA SETS = 3:**

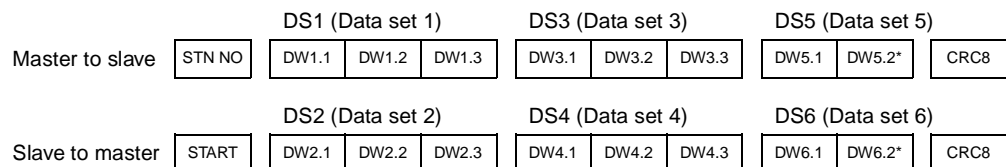

\*Included in Word Mode only

**07 DATA SET1 CONST** This parameter changes the polling time of the first data set. The default value (1) indicates that the first data set pair (usually DS1 and DS2) are sent during every polling sequence (every 6 milliseconds).

**08 DATA SET2 CONST** These parameters change the polling times of the second pair of data sets (usually DS3 and DS4) and third data set pair (usually DS5 and DS6) respectively. Allowable values are 1 to 32767, one unit corresponding to 6 milliseconds.  
**09 DATA SET3 CONST**

**10 DATA SET OFFSET** Normally, data sets DS1, DS3 and DS5 are sent by the master to the drive, whereas data sets DS2, DS4 and DS6 are sent by the drive to the master. The starting data set number can be offset by using this parameter.

The first data set number used equals the value of this parameter; e.g. if this parameter is set to 1, the first data set to be used is DS1.

By default, the value of this parameter is 1, thus the first data set used is DS1.

**Control Locations** ABB drives can receive control information from multiple sources including digital inputs, analogue inputs, the drive control panel and a communication module (e.g. NCSA-01). ABB drives allow the user to separately determine the source for each type of control information (Start, Stop, Direction, Reference, Fault Reset, etc.). In order to give the fieldbus master station the most complete control over the drive, the communication module must be selected as source for this information. See the user documentation of the drive for information on the selection parameters.

## Chapter 6 – Communication

---

### **Contents**

This chapter describes the contents of the messages used for communication between the CS 31 and the drive. Also introduced are the addresses in the CS 31 master register areas into which the drive data is written.

### **CS 31 Messaging**

In the CS 31 system, the master sends messages cyclically to each slave station. Each slave responds to messages with the correct address and takes the actions requested by the master. The message frames consist of a start/identification byte, one to three data sets, and an error check byte.

---

**Note:** Only cyclic drive control and feedback data can be transmitted via the CS 31 bus. The parameters of the drive cannot be read or adjusted through the CS 31 bus.

---

### **Memory Mapping**

The input/output memory system of the CS 31 master is divided between the devices connected to the CS 31 bus. The memory areas are as follows:

Binary inputs of CS 31 remote modules	E00,00 ... E57,15
Binary outputs of CS 31 remote modules	A00,00 ... A57,15
Word inputs of CS 31 remote modules	EW00,00 ... EW5,15
Word outputs of CS 31 remote modules	AW00,00 ... AW5,15

The NCSA-01 can be used either in Binary or Word Mode (see parameter 03 MODULE ID in Chapter 5). The control data can be modified by the CS 31 master program either on a bit (*A XX,YY*) or word (*AW XX,YY*) basis, where *XX* is the address (station number) of the NCSA-01 module and *YY* is the address of the variable. For detailed information on selecting the appropriate mode, consult the *CS 31 Program Manual*.

**Drive Control Data** The figure below shows the message frame for drive control data.

**Note:** The numbering of the control data sets shown below applies when Parameter 10 DATA SET OFFSET is set to its default, 1. For information on selecting different data set numbers, see Chapter 5, section 10 DATA SET OFFSET.

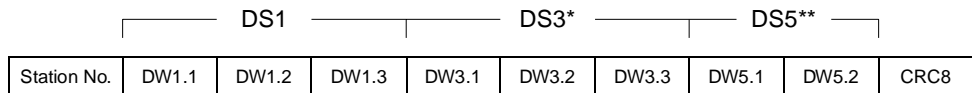

\*Included only when Parameter 06 DATA SETS = 2 or 3

\*\*Included only when Parameter 06 DATA SETS = 3

The drive control data is mapped in the memory of the CS 31 master as follows:

Data		Memory Location (XX = Station Number)		
		03 MODULE ID = WORD		03 MODULE ID = BINARY
		05 ADDR INDEX = LOWER	05 ADDR INDEX = UPPER	
DS1	DW1.1	AW XX,00	AW XX,08	A XX,0...15
	DW1.2	AW XX,01	AW XX,09	A XX+1,0...15
	DW1.3	AW XX,02	AW XX,10	A XX+2,0...15
DS3	DW3.1	AW XX,03	AW XX,11	A XX+3,0...15
	DW3.2	AW XX,04	AW XX,12	A XX+4,0...15
	DW3.3	AW XX,05	AW XX,13	A XX+5,0...15
DS5	DW5.1	AW XX,06	AW XX,14	A XX+6,0...15
	DW5.2	AW XX,07	AW XX,15	N/A
	DW5.3	N/A	N/A	N/A



**The Control Word and the Status Word**

The Control Word is the principal means for controlling the drive from a fieldbus system. It is sent by the fieldbus master station to the drive, the adapter module acting as a transparent link. The drive switches between its states according to the bit-coded instructions on the Control Word. The Status Word is a word containing status information, sent by the drive to the master station. The contents of both the Control and Status Words are explained in the drive documentation.

The Control and Status Words are not altered by the NCSA-01 in any way, excepting Bit 15 of the Status Word, which is turned on by the module in case of an error in the DDCS communication between the module and the drive.

**References**

References are 16-bit words containing a sign bit and a 15-bit integer. A negative reference (indicating reversed direction of rotation) is formed by calculating the two's complement from the corresponding positive reference.

ABB drives can receive control information from multiple sources including analogue and digital inputs, the drive control panel and a communication module (e.g. NCSA-01). In order to have the drive controlled through Interbus-S, the communication module must be defined as the source for control information, eg. Reference. The scaling of the integer received from the master as Reference is drive-specific. See its Programming Manual for available control source selections and Reference scaling factors.

**Actual Values**

Actual Values are 16-bit words containing information on the operation of the drive. The functions to be monitored are selected with a drive parameter. The scaling of the integers sent to the master as Actual Values depends on the selected function. Please refer to the drive documentation.

# Chapter 7 – Fault Tracing

---

## **Contents**

This chapter gives diagnostics information for finding out the root causes and corrections to the most common problems with the NCSA-01 module.

## **Installation Problems**

Verify all the connections of the module. Check that

- the CS 31 bus cable is connected correctly to terminal block X2.
- 24 V d.c. power is connected to the power connectors.
- the fibre cables between the drive and the NCSA-01 are correctly connected, so that the fibre cable connector colours match the drive and module connector colours.

## **Drive Setup Problems**

<b>Problem</b>	<b>Remedy</b>
The fieldbus parameters are not visible on the drive control panel.	Activate the fieldbus module according to the instructions in the drive manuals.
Drive parameters can be read, but control commands (Start/Stop, Reference, etc.) do not work.	Check that the drive has the fieldbus adapter selected as the source of these commands (see the drive manuals).

## **PLC Programming Problems**

Consult the documentation of the CS 31 master.

## Status LEDs

The NCSA-01 has three status LEDs. These are from top to bottom:

**DDCS** The *DDCS* LED indicates the status of the optical DDCS link between the NCSA-01 and the drive.

The *DDCS* LED should normally be illuminated. If it remains off after initialisation, the optical DDCS link between the NCSA-01 and the drive has not been successfully established; if the LED flashes, there are errors on the link. All errors in the DDCS communication are reported by the module to the master (using Bit 15 of the Status Word). If more than 1000 consecutive errors are detected, the DDCS link is re-initialised.

If DDCS errors occur, check the fibre optic cables visually for dirt or flaws. Ensure the connection is correct and the cables properly inserted. If these measures do not rectify the problem, try new cables. If errors still occur, contact an ABB service representative.

**UART** The *UART* LED indicates the status of CS 31 communication.

The *UART* LED should normally be illuminated. A flashing *UART* LED indicates errors in the data transfer on the CS 31 bus. If errors occur, check the wiring according to the instructions given in Chapter 4.

**ERROR** The *ERROR* LED indicates a hardware error, and should always be off. If the *ERROR* LED is illuminated, contact an ABB service representative.

## Normal Power-up Sequence

On module power-up, the NCSA-01 goes through a self-test sequence. The normal power-up procedure is as follows:

- All LEDs are lit for the duration of the RAM test. If the test is passed, all LEDs are turned off.
- The *DDCS* LED lights as soon as the optical DDCS link between the NCSA-01 and the drive has been initialised. The initialisation may take several seconds. (The first message sent to the drive is a production test message.)
- The *UART* LED lights as soon as the CS 31 bus has been initialised. The NCSA-01 is now operating.

## Appendix A – Technical Data

---

### **DDCS Link**

**Compatible Devices:** All ABB Fieldbus Adapter modules, ABB ACS 300, ACS 400, ACS/ACP/ACC/ACF 600, ACS 1000, DCS 500 Drives

**Size of the Link:** 2 stations (3 to 248 in Multiple Drive Control)

**Medium:** Fibre optic cable

- Construction: Plastic core, diameter 1 mm, sheathed with plastic jacket
- Attenuation: 0.31 dB/m
- Maximum Length between Stations: 10 m
- Specifications:

Parameter	Minimum	Maximum	Unit
Storage Temperature	-55	+85	°C
Installation Temperature	-20	+70	°C
Short Term Tensile Force		50	N
Short Term Bend Radius	25		mm
Long Term Bend Radius	35		mm
Long Term Tensile Load		1	N
Flexing		1000	cycles

**Topology:** Point-to-point (Ring in Multiple Drive Control)

**Serial Communication Type:** Asynchronous, half Duplex

**Transfer Rate:** 4 Mbit/s

**Protocol:** Distributed Drives Communication System (DDCS)

**Connectors:** Blue – receiver; grey – transmitter

### Fieldbus Link

**Compatible Devices:** All devices compatible with the ABB Procontic CS 31 protocol

**Size of the Link:** 22 stations

**Medium:** Shielded, twisted pair RS-485 cable

- Termination: 120  $\Omega$ , ¼ W resistor (built in the NCSA-01 module)
- Maximum Bus Length: 500 m
- Specifications:

Parameter	Minimum	Maximum	Unit
Cross-section	0.22	0.8	mm <sup>2</sup>
Twists	10		/m
Resistance		100	$\Omega$ /km
Impedance Characteristics	100	150	$\Omega$
Capacitance		150	nF/km

- Examples: Alcatel MCX-T, Draka Dracoda 2903

**Topology:** RS-485 Serial Link

**Serial Communication Type:** Asynchronous, half Duplex

**Transmission Rate:** 187.5 kbitps

**Protocol:** CS 31

**NCSA-01**

**Enclosure:** Plastic, dimensions 45 x 75 x 105 mm; degree of protection IP 20

**Mounting:** Onto a standard mounting rail

**Settings:** Via drive interface (control panel)

**Current Consumption:** 65 mA at 24 V d.c.

**Connectors:**

- Light transmitter (grey) and receiver (blue) (Hewlett-Packard Versatile Link) for connection to the drive
- One Combicon MVSTBW 2,5/8-ST-5,08 (8-pole, cross-section 2.5 mm<sup>2</sup> max.) screw terminal block for the fieldbus and power supply:

X2		Description
1	D(P)	D(P) = B = Data Positive (Conductor 1 in twisted pair) D(N) = A = Data Negative (Conductor 2 in twisted pair) DG = Data Ground
2	D(N)	
3	DG	
4	SHF	Cable screen AC earthing (via an RC filter)
5	SH	Cable screen earthing (directly earthed)
6	0V	Power supply for the module (24 V d.c. ± 10 %); screened cable.
7	+24 V	
8	PE	Earth

**General:**

- All materials are UL/CSA approved
- Complies with EMC Standards EN 50081-2 and EN 50082-2



## Appendix B – Ambient Conditions

---

### **Ambient Conditions, Operation**

Ambient operating conditions refer to the conditions the option module is subjected to when installed for stationary use.

**Air Temperature:** 0 to +50 °C

**Relative Humidity:** 5 to 95 %, no condensation allowed. Maximum allowed relative humidity is 60 % in the presence of corrosive gases.

**Contamination Levels:**

Chemical gases: IEC 721-3-3, Class 3C2

Solid particles: IEC 721-3-3, Class 3S2

**Installation Site Altitude:** 0 to 2000 m above sea level. If the installation site is higher than 2000 m above sea level, please contact your local ABB distributor or office for further information.

**Vibration:** Max 0.3 mm (2 to 9 Hz), max 1 m/s<sup>2</sup> (9 to 200 Hz) sinusoidal (IEC 68-2-6)

Shock: Max 70 m/s<sup>2</sup>, 22 ms (IEC 68-2-27)

### **Ambient Conditions, Storage**

Ambient storage conditions refer to the conditions the option module is subjected to during storage in the protective package.

**Temperature:** -40 to +70 °C.

Relative Humidity: Less than 95 %, no condensation allowed

Atmospheric Pressure: 70 to 106 kPa

Vibration: Max 0.3 mm (2 to 9 Hz), max 1 m/s<sup>2</sup> (9 to 200 Hz) sinusoidal (IEC 68-2-6)

Shock: Max 100 m/s<sup>2</sup>, 11 ms (IEC 68-2-27)

### **Ambient Conditions, Transportation**

Ambient transportation conditions refer to the conditions the option module is subjected to during transportation in the protective package.

**Temperature:** -40 to +70 °C

**Relative Humidity:** Less than 95 %, no condensation allowed.

**Atmospheric Pressure:** 60 to 106 kPa

Vibration: Max 3.5 mm (2 to 9 Hz), max 15 m/s<sup>2</sup> (9 to 200 Hz) sinusoidal (IEC 68-2-6)

Shock: Max 100 m/s<sup>2</sup>, 11 ms (IEC 68-2-27)

Bump: Max 300 m/s<sup>2</sup>, 6 ms (IEC 68-2-29)

Free Fall: 250 mm







NCSA-01/EN  
3AFY 58920029 R0225  
EFFECTIVE: 1.12.1999  
SUPERSEDES: 1996-02-01

---

**ABB Industry Oy**

Drives

P.O.Box 184

FIN-00381 Helsinki

FINLAND

Telephone: +358 10 22 2000

Telefax: +358 10 22 22681

Internet: <http://www.abb.com/automation>