

ACS 600 MultiDrive

efesotomasyon.com

System Description

Air-cooled Drives

efesotomasyon.com



Manuals for the Air-cooled ACS 600 MultiDrive *(English Originals)*

GENERAL MANUALS

*Safety and Product Information EN 63982229

- Complete general Safety Instructions
- Technical data for DSU and TSU supplies and Drive Sections: ratings, power losses, dimensions, weights, fuses etc.

*System Description EN 63700151

General description of ACS 600 MultiDrive

*Hardware Manual EN 63700118

- General Safety Instructions
- Hardware description of the Drive Section
- Cable selection
- ACS 600 MultiDrive mechanical and electrical installation
- Hardware commissioning of the Drive Section
- Preventive maintenance of ACS 600 MultiDrive

**Modules Product Catalogue EN 64104268

- Supply Unit components
- Drive Unit components
- Dynamic Braking Units
- DriveWare information
- Dimensional drawings
- Single line diagrams
- Auxiliary power consumption
- Master component tables

**Modules Installation Manual EN 64119010

- Cabinet assembly
- Wiring

**Grounding and Cabling of the Drive System EN 61201998

- Grounding and cabling principles of a variable speed drive system

**EMC Compliant Installation and Configuration for a Power Drive System EN 61348280

* Included with cabinet-assembled systems only

** Included in Modules deliveries only

SUPPLY UNIT USER'S MANUALS (depending on the supply type one of these manuals is included in the delivery)

Diode Supply Unit (DSU) EN 61451544

- DSU specific Safety Instructions
- DSU hardware and software descriptions
- DSU commissioning
- Earth fault protection options

Thyristor Supply Unit (TSU) EN 64170597

- TSU operation basics
- TSU firmware description
- TSU program parameters
- TSU commissioning

IGBT Supply Unit User's Manual (ISU) EN 64013700

- ISU specific Safety Instructions
- Main components of ISU
- ISU ratings
- ISU power losses
- ISU dimensions and weights
- ISU fuses
- ISU program parameters
- Earth fault protection options

FIRMWARE MANUALS FOR DRIVE APPLICATION PROGRAMS (appropriate manual is included in the delivery)

System EN 63700177

- Commissioning of the System Application Program
- Control Panel use
- Software description
- Parameters of the System Application Program
- Fault tracing
- Terms

Application Program Template EN 63700185

- Commissioning of the Drive Section
- Control Panel use
- Software description
- Parameters
- Fault tracing
- Terms

Standard EN 61201441

- Control Panel use
- Standard application macros with external control connection diagrams
- Parameters of the Standard Application Program
- Fault tracing
- Fieldbus control

Note: a separate Start-up Guide is attached

Crane Drive EN 3BSE 011179

- Commissioning of the Crane Drive Application Program
- Control Panel use
- Crane program description
- Parameters of the Crane Drive Application Program
- Fault tracing

CONTROL SECTION MANUALS (delivered with optional Control Section)

Advant Controller 80 User's Manual EN 64116487

- AC 80 hardware and connections
- AC 80 software
- Programming
- Diagnostics

Advant Controller 80 Reference Manual PC Elements EN 64021737

- Description of PC and DB elements

Advant Controller 80 Reference Manual TC Elements EN 64331868

- Description of TC elements

BRAKING SECTION MANUAL (delivered with optional Braking Section)

ACA 621/622 Braking Sections User's Manual EN 64243811

- Installation, Start-up, Fault tracing, Technical data
- Dimensional drawings

MANUALS FOR OPTIONAL EQUIPMENT (delivered with optional equipment)

Fieldbus Adapters, I/O Extension Modules, Braking Choppers etc.

- Installation
- Programming
- Fault tracing
- Technical data

Air-cooled ACS 600 MultiDrive

System Description

efesotomasyon.com

3AFY 63700151 R0325

EFFECTIVE: 8.11.2000
SUPERSEDES: 18.09.1997

Table of Contents

Manuals for the Air-cooled ACS 600 MultiDrive (English Originals)

Table of Contents

Chapter 1 – Introduction

| | |
|--|-----|
| About the User's Manuals | 1-1 |
| Common Abbreviations | 1-1 |
| ACS 600 Product Family and ACS 600 MultiDrive in Brief | 1-2 |
| Main Features | 1-3 |
| Mechanical Construction | 1-4 |
| Bus Bars | 1-5 |
| Degree of Protection | 1-6 |
| EMC Design | 1-6 |
| IP 21 | 1-6 |
| IP 22 | 1-6 |
| IP 42 | 1-6 |
| IP 54R | 1-6 |
| Cables | 1-6 |

Chapter 2 – Supply Section

| | |
|--|------|
| Diode Supply Section | 2-1 |
| Overall View | 2-1 |
| Auxiliary Control Unit (ACU) | 2-2 |
| Options | 2-2 |
| Incoming Unit (ICU) | 2-3 |
| Diode Supply Unit (DSU) | 2-4 |
| Features | 2-4 |
| Six Pulse Connection | 2-4 |
| Twelve Pulse Connection | 2-5 |
| Options | 2-5 |
| Thyristor Supply Section | 2-6 |
| Overall View | 2-6 |
| Auxiliary Control Unit (ACU) | 2-7 |
| Incoming Unit (ICU) | 2-7 |
| Thyristor Supply Unit (TSU) | 2-8 |
| Features | 2-8 |
| Six Pulse Bridge Connection | 2-8 |
| Twelve Pulse Bridge Connection | 2-9 |
| Optional Devices | 2-10 |
| IGBT Supply Section | 2-11 |
| Overall View | 2-11 |
| Auxiliary Control Unit (ACU) | 2-12 |

Table of Contents

| | |
|--|------|
| Incoming Unit (ICU) | 2-12 |
| IGBT Supply Unit (ISU) | 2-13 |
| Main Circuit Diagram | 2-13 |
| Control | 2-13 |
| Harmonics | 2-13 |
| ISU and DSU in Parallel | 2-13 |
| Chapter 3 – Drive Sections | |
| Inverter Module Frame Sizes | 3-1 |
| Single R2i - R5i Units | 3-2 |
| Single R6i - R12i Units | 3-2 |
| Parallel Units | 3-2 |
| Drive Control | 3-2 |
| Optional Features | 3-3 |
| Disconnect Switch with Charging Control | 3-3 |
| External Control Power Supply | 3-3 |
| Prevention of Unexpected Start-up | 3-3 |
| Control Panel | 3-3 |
| LED Panel | 3-3 |
| Fieldbus Adapter Modules | 3-3 |
| Analogue I/O Extension Module | 3-3 |
| Digital I/O Extension Module | 3-3 |
| Chapter 4 – Braking Section | |
| Overall View | 4-1 |
| Attenuator | 4-2 |
| Braking Resistors | 4-2 |
| Braking Chopper | 4-2 |
| Braking Section Selection Tool | 4-2 |
| Chapter 5 – Control Section and User Interfaces | |
| Control Section Overview | 5-1 |
| User Interfaces | 5-1 |
| LED Monitoring Display | 5-2 |
| Drives Control Panel CDP 312 | 5-3 |
| Graphical Operating Panel (GOP) | 5-3 |
| Chapter 6 – Process Control | |
| General Information | 6-1 |
| Automation | 6-1 |
| Advant Fieldbus 100 (AF100) | 6-2 |
| Inputs/Outputs | 6-2 |
| Advant Controller 80 (AC 80) | 6-3 |
| DriveBus | 6-4 |
| ModuleBus | 6-5 |
| Special I/O Link | 6-6 |

| | |
|---|------|
| Fieldbus Link | 6-7 |
| Panel/Printer Link | 6-8 |
| Tool Link | 6-8 |
| Related Devices | 6-9 |
| Application and Motor Controller (NAMC) | 6-10 |
| Fieldbus Adapter Modules | 6-11 |

Chapter 7 – PC Tools

| | |
|-----------------------------|-----|
| DriveWare PC Tools | 7-1 |
| DriveWindow | 7-1 |
| DriveSize | 7-2 |
| DriveBuilder | 7-2 |
| DriveSupport | 7-2 |
| DriveLink | 7-3 |
| DriveDebug | 7-3 |
| AdvaBuild for Windows | 7-4 |

Table of Contents

Chapter 1 – Introduction

About the User's Manuals

This manual includes an overall description of the Air-cooled ACS 600 MultiDrive. Since the ACS 600 MultiDrive is customised out of a various pre-designed components, the user documentation is also split into parts. On the inside of the front cover there is a complete list of the manuals. See “a component specific manual” for a detailed information on a particular issue.

Common Abbreviations

Several abbreviations are used in this manual. They are explained briefly in the table below.

Table 1-1 Common abbreviations of this manual

| | |
|-------------|---|
| ACU | Auxiliary Control Unit |
| AMC | Application and Motor Controller is a single board that has a powerful digital signal processor to implement the inverter and motor control. |
| APC2 | Application Controller is a single board that can control up to four inverters (AMC) and communicate to several fieldbus systems and I/O devices. |
| DDCS | Distributed Drives Communication System is a communication protocol that uses a 4 Mbit/s fibre optical data bus dedicated to ABB drives. |
| DSU | Diode Supply Unit |
| DTC | Direct Torque Control is a motor control method. |
| FIU | Filter Unit |
| I/O | Input / Output |
| ICU | Incoming Unit |
| IGBT | Insulated Gate Bipolar Transistor is a voltage controlled semiconductor type that is widely used in inverters due to the easy controllability and high switching frequency. |
| ISU | IGBT Supply Unit |
| LCD | Liquid Crystal Display |
| LED | Light Emitting Diode |
| NAC | New AC drive |
| NAIO | Nac Analogue I/O extension module |
| NAMC | Nac Application and Motor Control board |
| NBIO | Nac Basic I/O unit |
| NDCU | Nac Drive Control unit |
| NDIO | Nac Digital I/O extension module |
| NDSC | Nac Diode Supply unit Control board |

| | |
|-------------|--|
| NPCT | Nac Pulse Counter and Time unit |
| NTAC | Nac pulse encoder interface module |
| NWIO | Nac Watchdog and I/O module |
| PLC | Programmable Logic Controller |
| PPCS | Power Plate Communication System is a communication protocol that uses an 8 Mbit/s fibre optical data bus dedicated to ABB drives. |
| RFI | Radio Frequency Interference |
| TSU | Thyristor Supply Unit |

**ACS 600 Product
Family and ACS 600
MultiDrive in Brief**

efesotomasyon.com

The ACS 600 product family includes:

- a fully customised product for demanding system applications (ACS 600 MultiDrive)
- drives for general purpose standard applications (ACS 600 SingleDrive)
- drives for special applications such as positioning and cranes (ACS 600 CraneDrive, ACS 600 MotionControl)
- drives for special branches (ACS 600 MarineDrive)

ACS 600 MultiDrive is designed for the optimum configuration in multiple drive applications. Whether an application involves a drive or two hundred drives, there is an optimum configuration to meet the application need.

ACS 600 MultiDrive consists of four different section types: a supply section; a braking section, several drive sections and control sections. The section type determines which type of equipment are in each section cubicle. The modularity is a key-feature of the construction.

Main Features A high degree of commonality exists throughout the complete ACS 600 product family. Features such as mechanical construction of inverter modules, DTC motor control performance and IGBT power semiconductor technology are common for the complete ACS 600 product family.

In addition, many man-machine interfaces and PC tools for programming, commissioning and servicing are the same for the complete ACS 600 product family.

The main features of the ACS 600 MultiDrive include:

- **Direct Torque Control**
 - Excellent torque response and control
 - Good performance at low speeds
 - Low audible noise
- **Cabinet**
 - Safety features such as separate compartment for standard flat bus bars and encapsulated sections
 - Easy access to main circuit connections with a thermal camera
 - Easy re-tightening of main circuit connections
- **Common DC Bus Connection**
 - Shared regenerative energy among drives
 - Single rectification unit
 - Floor space-saving
- **Comprehensive Set of PC Tools**
 - Familiar and user-friendly Windows environment
 - Easy to learn and use
- **Process Controllers**
 - For the distributed control of a large drive system, ACS 600 MultiDrive utilises Application Controllers, which can be used both with the ABB AC and DC drives.
 - Small systems can be controlled with a powerful drive controller, the Application and Motor Controller by programming the required application software to the circuit memory.

**Mechanical
Construction**

ACS 600 MultiDrive cabinet lineup is shown below.



ACS 600 MultiDrive cabinet has commonality with other ABB cabinets in business areas other than drives such as distribution and installation. The mechanical construction enables the use of a thermal camera in critical main circuit connections. The connections can also be re-tightened easily because the nut does not fall off from the hold block.

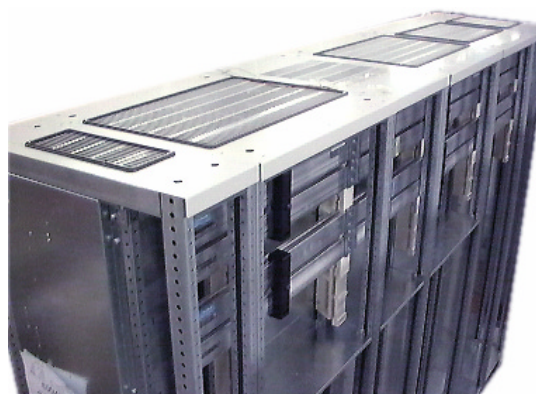

Figure 1-1 The frame is strong and includes a compartment for standard flat bus bars (no hat installed yet)

Bus Bars The separate compartment for standard flat AC or DC bus bars is a well appreciated safety feature in high powers.

efesotomasyon.com

The bus bars of the cabinet are typically aluminium as a standard (copper bus bars with high currents). Optional copper or tin plated copper bus bars are available to implement the AC or DC bus.

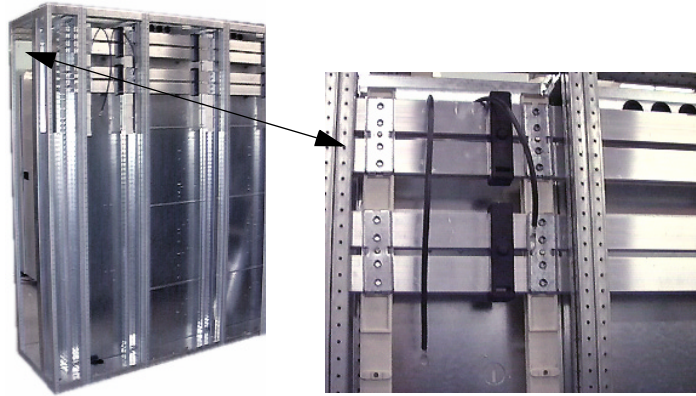

Figure 1-2 DC bus is implemented with standard flat bars (inverter cables are not tightened and placed yet)

- Degree of Protection** The cabinet complies with several International Protection (IP) standards. In addition, it is designed to comply with European Union electromagnetic compatibility directives.
- EMC Design** The joints between the cover plates and the frame are sealed. The cabinet is equipped with cable sleeves for earthing the cable screens. Conductive gaskets are provided for doors and control cables to comply with European Union EMC directives.
- IP 21** As a standard, the cabinet is protected against vertically falling water drops. With doors open, the circuits are protected against solid foreign objects the diameter of which is 12,5 mm and greater.
- IP 22** This optional class offers protection against vertically falling water drops when the cabinet is tilted at any angle up to 15° on either side of the vertical position.
- IP 42** This optional protection class defines that solid foreign objects the diameter of which is one millimetre and greater have no entrance into the cabinet. A metallic net with meshes smaller than one millimetre is provided.
- IP 54R** This optional protection class is dust-tight. This is achieved with air inlet filters. They can be easily replaced while the drive is operating.
- The “R” means that the cabinet is provided with a special roof which contains a clamp for an air channel. Thus, the air outlet is always connected to the air duct of the industrial plant.
- Cables** As a standard, the cables enter and exit through the cabinet bottom. Cable entry and exit through the cabinet top is optional (in some cases, an extra cabinet is required).

Chapter 2 – Supply Section

Diode Supply Section

The diode supply section is functionally divided into three parts: Auxiliary Control Unit (ACU), Incoming Unit (ICU), and Diode Supply Unit (DSU).

Overall View

The figures below show the ACS 600 MultiDrive with diode supply section. The main components typically included in the supply section are drawn using schematic symbols.

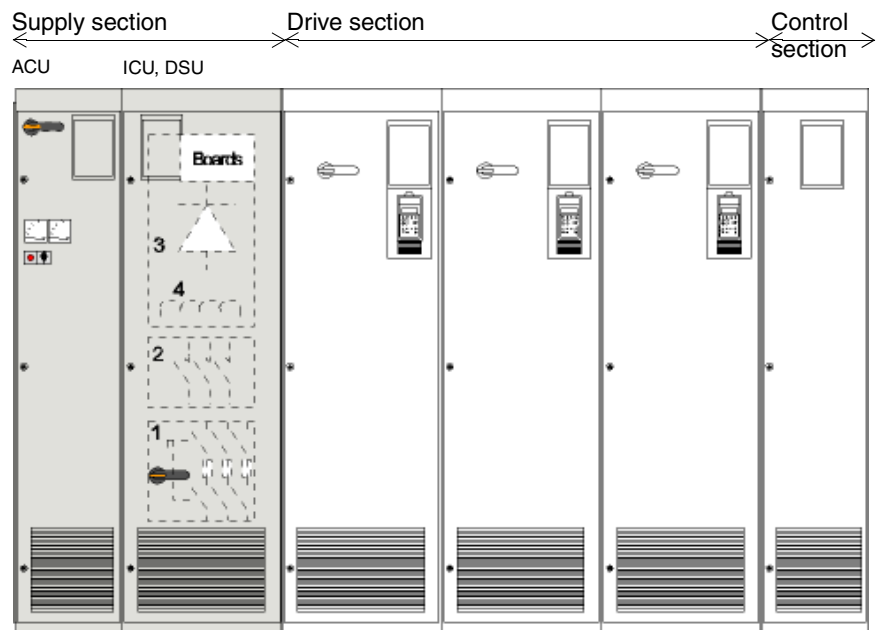

Supply section with up to B3 size diode supply module:

| Unit | Description | No. |
|------|---|-----|
| ACU | 230 VAC (115 VAC) auxiliary circuit equipment (e.g. starting switch, emergency stop switch, relays, protective circuit breakers for 230 VAC circuits) | - |
| ICU | Main disconnect and fuses (fuse-switch) | 1 |
| | Main contactor | 2 |
| DSU | Rectifying diode bridge | 3 |
| | Intermediate circuit DC reactor | 4 |

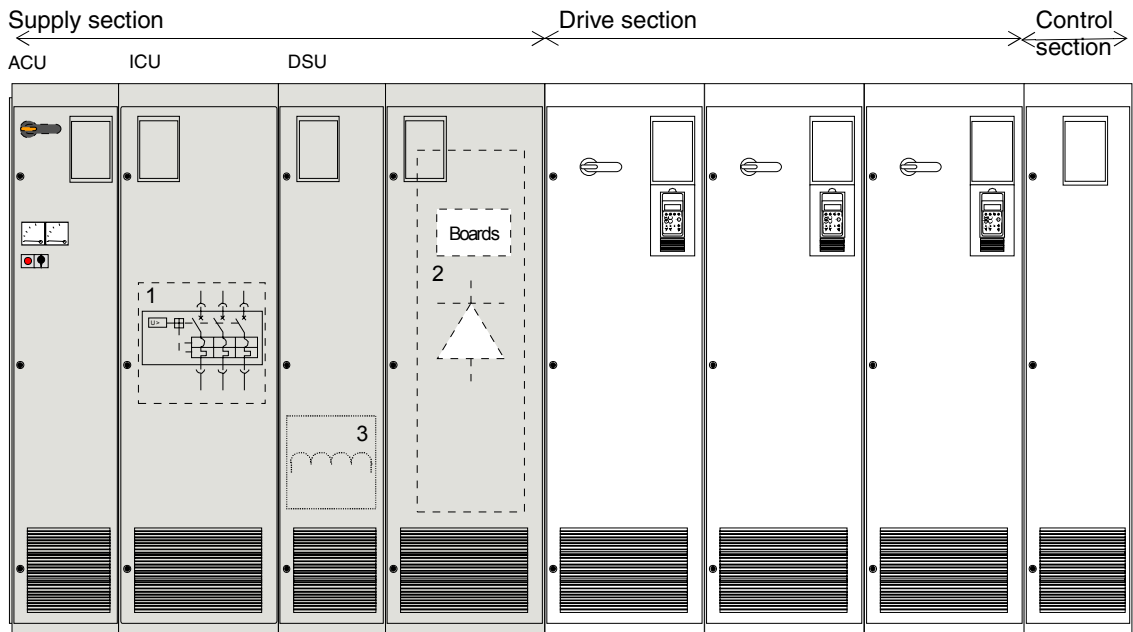

Supply section with size B4 and B5 diode supply modules:

| Unit | Description | No. |
|------|---|-----|
| ACU | 230 VAC (115 VAC) auxiliary circuit equipment (e.g. starting switch, emergency stop switch, relays, protective circuit breakers for 230 VAC circuits) | - |
| ICU | Main breaker (including: disconnecting device, load current on/off switch, long term thermal protection, instantaneous magnetic protection) | 1 |
| DSU | Rectifying diode bridge | 2 |
| | Intermediate circuit DC reactor | 3 |

Auxiliary Control Unit (ACU)

The Auxiliary Control Unit includes a 115 VAC or a 230 VAC auxiliary transformer. In addition, a 24 VDC power source for an emergency stop signal is located in the auxiliary control unit.

Options

AC voltage measurement meter can be selected to monitor all three phase-to-phase voltages of the net supply.

One to three AC current measurement meters can be selected to monitor one or the three phases of the net supply.

An insulation monitor can be used for earth fault protection in IT (floating) networks.

An arc monitor system includes optical sensors to detect the electric arc in the bus bar compartment.

Incoming Unit (ICU) The incoming unit includes supply cable terminals and the main disconnecting switching and protection equipment.

The table below shows the alternative components available for a supply section including a six pulse Diode Supply Unit (DSU).

| Fig. | Equipment | Supply Converter Module Size | | | | |
|------|------------------------------------|------------------------------|-----------|-----------|---|---|
| | | B1 | B2 | B3 | B4 | B5 |
| 1 | Load switch (OETL) | - | - | - | All except ACA 638-1290-3 ACA 636-2130-3 ACA 638-1615-5 ACA 638-2660-5 ACA 639-1615-6 ACA-639-2660-6 and 800 V units | All except ACA-636-3220-3 ACA-636-4030-5 ACA-636-4700-5 ACA-636-4950-6 ACA-636-6500-6 and 800 V units |
| 2 | Fuse switch (OESA) + Contactor *) | - | All types | All types | Only ACA 632-0850-6 ACA 636-1615-6 ACA 633-1700-6 | - |
| 3 | Air circuit breaker (ABB SACE) | - | - | - | All except ACA 632-0850-6 ACA 636-1615-6 ACA 633-1700-6 | All types |
| | Air circuit breaker (Merlin Gerin) | - | - | - | All except ACA 632-0850-6 ACA 636-1615-6 ACA 633-1700-6 | All types |

*) All Thyristor Supply Sections with B1 module has a fuse switch

PDM-code: 00010321.xls - Rev K

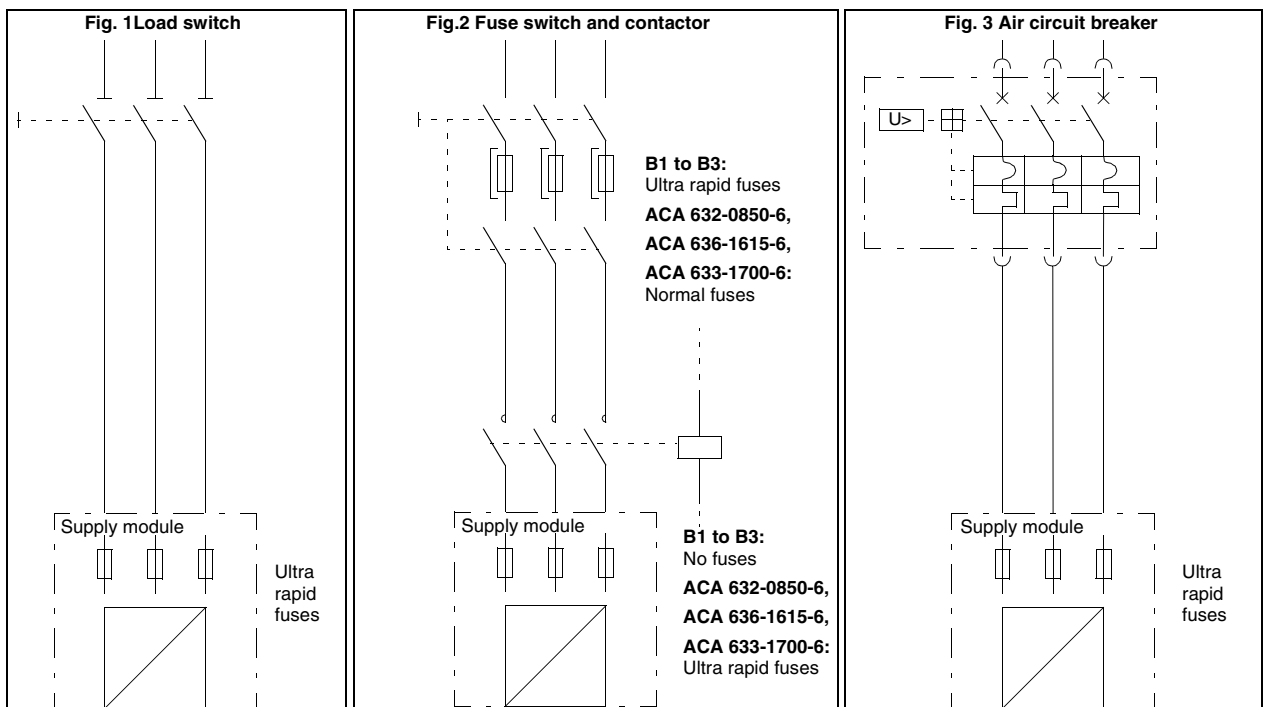

Diode Supply Unit (DSU)

A diode-thyristor bridge converts three phase AC input into DC plus and minus outputs. The thyristor firing angle is controlled during power-up when charging the intermediate circuit capacitors. No separate charging circuit is needed.

The DC reactor is used to smooth the output DC current. DC capacitors for smoothing the DC voltage are located inside inverter modules. A cooling fan is provided to transfer the heat loss outside.

Features

A Diode Supply Unit has a control board which can provide information such as AC/DC voltage and current measurements, phase lost indication, bridge overtemperature and earth fault via an optical DDCS communication link.

The supply unit has a main contactor or an air circuit breaker control via digital I/Os. The cooling fan is supervised with a relay contact.

Six Pulse Connection

A six pulse diode bridge consists of three thyristors and three diodes.

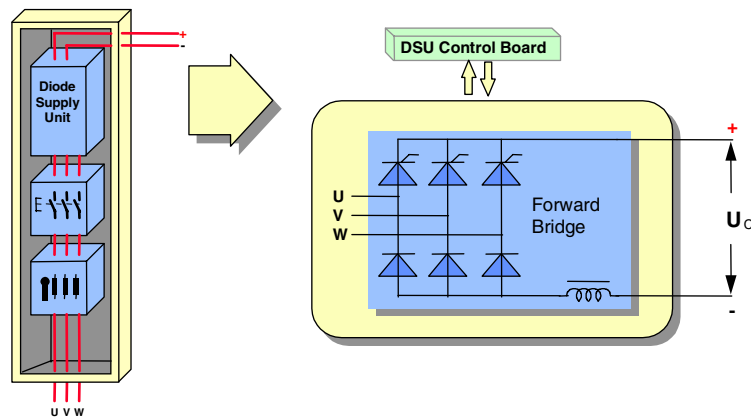
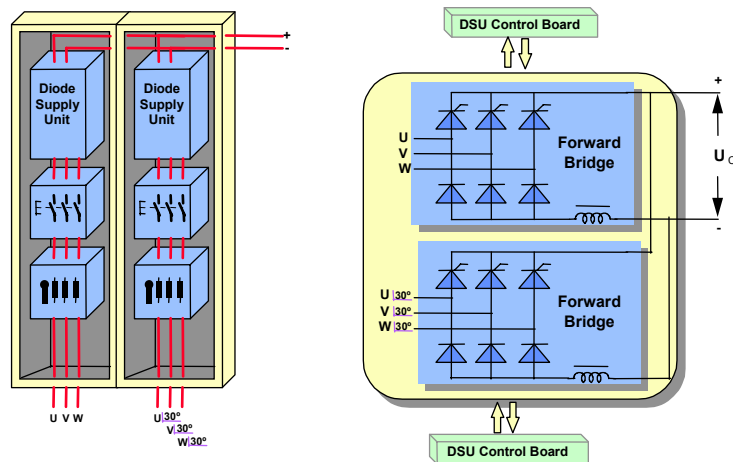

Figure 2-1 A 525 kVA diode supply unit with a six pulse bridge connection

Twelve Pulse Connection A twelve pulse diode bridge consists of two diode supply sections which are connected in parallel. The supply is phase shifted by 30° for one of the diode supply units.



Two 525 kVA diode supply units with a twelve pulse bridge connection

Twelve pulse supply is used when:

- A high power supply is needed.
- The total harmonics distortion needs to be reduced. The 12-pulse supply remarkably decreases the harmonics fed back to the supply network by eliminating the 5th and 7th harmonics.
- A supply backup (redundancy) is required to minimise the process down-time in case of failures.

Options Earthing switch

The device is used to earth the AC bus bars for safety reasons when work is being done on the system. The device is mechanically or electrically interlocked with the main switch and can be used only when the main switch has been disconnected.

RFI filter

The RFI line filter is used for suppressing conducted emissions from ACS 600 MultiDrive to network. The RFI filter must not be used in IT (floating) networks. Read more from *ACS 600 MultiDrive Safety and Product Information manual* (EN 3AFY 63982229).

Cables/bus bars top entry

The cables/bus bars can enter and exit from the top. In lower power ratings (≤ 525 kVA), an extra cubicle is required to implement the cable top entry.

Thyristor Supply Section

The thyristor supply section is functionally divided into three parts: Auxiliary Control Unit (ACU), Incoming Unit (ICU), and Thyristor Supply Unit (TSU).

Overall View

The figure below shows the ACS 600 MultiDrive with thyristor supply section. The main components typically included in the supply section are drawn using schematic symbols.

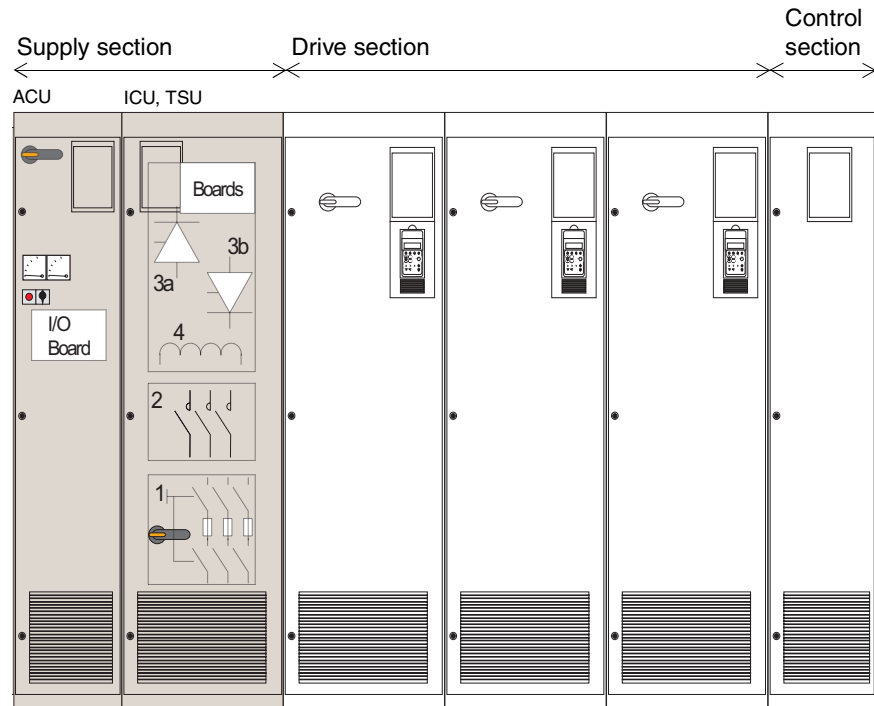

Supply section with up to B3 size thyristor supply module:

| Unit | Description | No. |
|------|---|-----|
| ACU | 230 VAC (115 VAC) auxiliary circuit equipment (e.g. starting switch, emergency stop switch, relays, protective circuit breakers for 230 VAC circuits). TSU I/O board | - |
| ICU | Main disconnect and fuses (fuse-switch) | 1 |
| | Main contactor | 2 |
| TSU | Rectifying (forward) thyristor bridge | 3a |
| | Regenerating (reverse) thyristor bridge | 3b |
| | Intermediate circuit DC reactor | 4 |

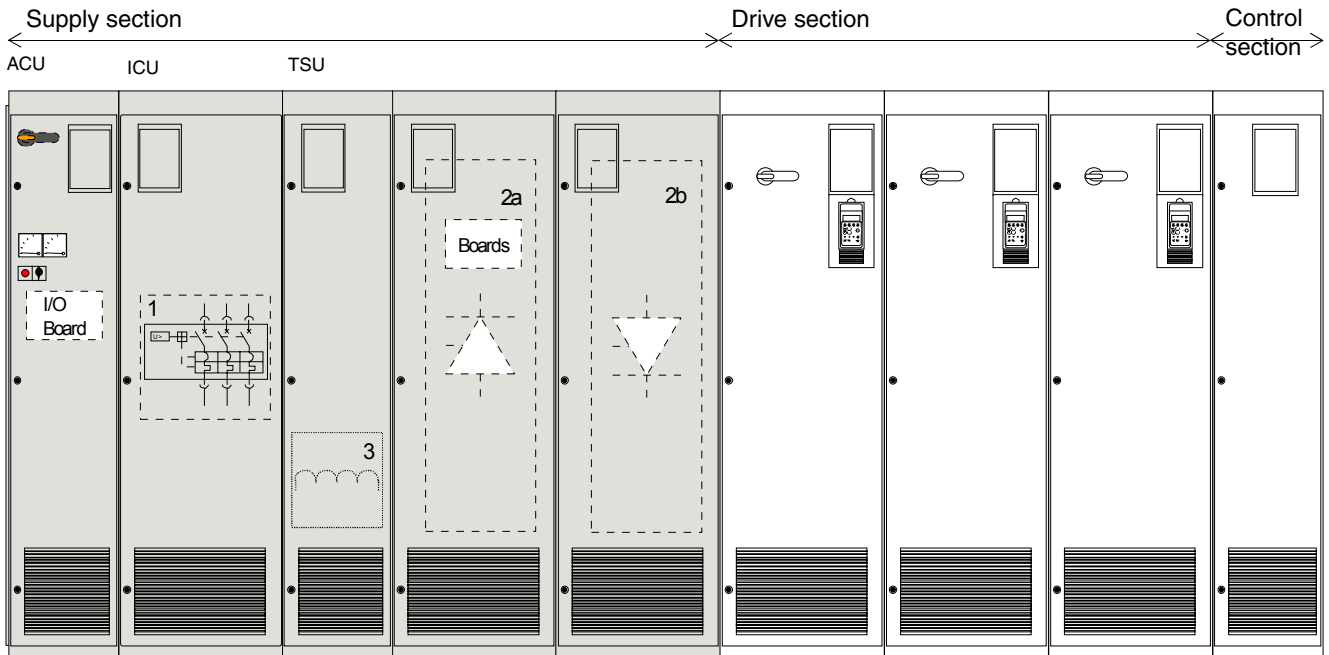

Supply section with size B4 or B5 thyristor supply modules:

| Unit | Description | No. |
|------|---|-----|
| ACU | 230 VAC (115 VAC) auxiliary circuit equipment (e.g. starting switch, emergency stop switch, relays, protective circuit breakers for 230 VAC circuits). TSU I/O board | - |
| ICU | Main breaker (including: disconnecting device, load current on/off switch, long term thermal protection, instantaneous magnetic protection) | 1 |
| TSU | Rectifying (forward) thyristor bridge | 2a |
| | Regenerating (reverse) thyristor bridge | 2b |
| | Intermediate circuit DC reactor | 3 |

Auxiliary Control Unit (ACU)

The design of the Auxiliary Control Unit is the same as in the diode supply section. See [Auxiliary Control Unit \(ACU\)](#) under *Diode Supply Section*.

Exception: The TSU I/O signal interface board is in the ACU cubicle, not inside the TSU module.

Incoming Unit (ICU)

The design of the Incoming Unit is the same as in the diode supply section. See [Incoming Unit \(ICU\)](#) under *Diode Supply Section*.

Thyristor Supply Unit (TSU)

Thyristor Supply Unit includes two six pulse bridges, motoring (forward) bridge and generating (reverse) bridge in anti-parallel connection to convert three phase AC input into DC plus and minus outputs and vice versa.

The DC reactor is used to smooth the output DC current. DC capacitors for smoothing the DC voltage are located inside inverter modules. A cooling fan is provided to transfer the heat loss outside.

Features

A thyristor supply unit has a microprocessor based control board which can provide information such as AC/DC voltage and current measurements, phase lost, bridge overtemperature and earth fault via an optical communication link.

The supply unit has a main contactor or an air circuit breaker control via digital I/Os. The cooling fan is supervised with a relay contact.

Six Pulse Bridge Connection

A six pulse thyristor bridge consists of six thyristors.

With power ratings greater than 525 kVA if high braking power is not needed, the generating bridge can be one step size smaller compared to the motoring bridge.

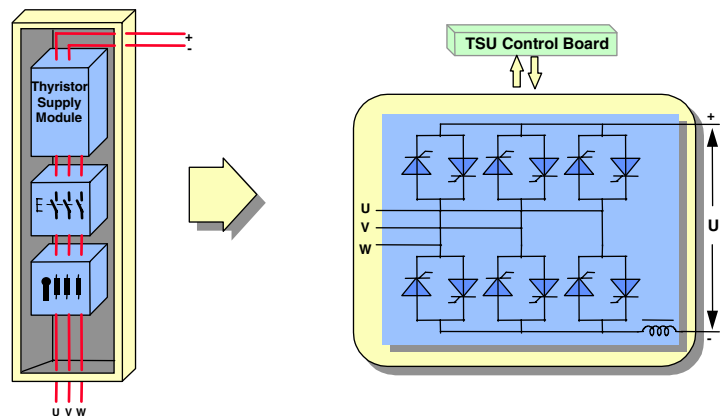

Figure 2-2 A 525/525 kVA thyristor supply unit with integrated motoring and generating bridges

Twelve Pulse Bridge Connection

In a 12-pulse supply, there are two Thyristor Supply Units connected in parallel. The operation is controlled by the master TSU, while the parallel slave TSU follows the commands of the master.

A 12-pulse supply is used when:

- A high power supply is needed.
- The total harmonics distortion needs to be reduced. The 12-pulse supply remarkably decreases the harmonics fed back to the supply network by eliminating the 5th and 7th harmonics.
- A supply backup (redundancy) is required to minimise the process down-time in case of failures.

Two 12-pulse configurations are shown below.

12/12-Pulse Configuration

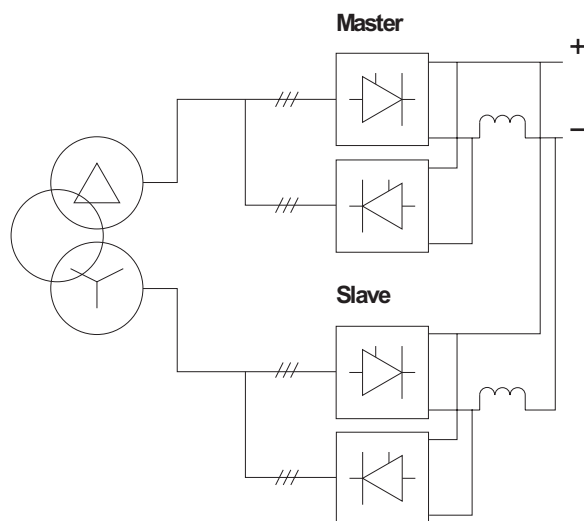

12/6-Pulse Configuration

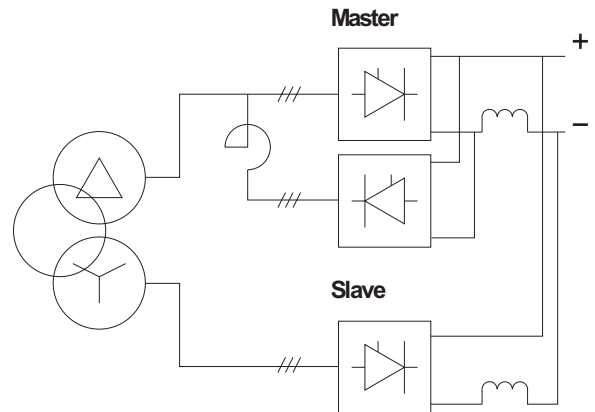

A 12/12-pulse configuration without autotransformers is shown in the figure above. Both the master TSU and the slave TSU have forward and reverse bridges enabling equal forward and reverse power flows.

A 12/6-pulse configuration is shown above. The supply is equipped with an autotransformer. A 12/6-pulse configuration is used if the maximum reverse power is equal or less than 50% of the forward power rating. In a 12/6-pulse supply, the master TSU has both the forward and reverse bridge, while the slave TSU has the forward bridge only.

Optional Devices

The supply network forms the thyristor bridge commutation circuit. In a weak supply network the commutation ability needs to be ensured through some extra arrangements:

- using a higher supply voltage than the nominal motor voltage. However, this arrangement consumes reactive power which is not usually desired because of the network voltage rise.
- using an optional autotransformer. This solution does not increase the consumption of reactive power.

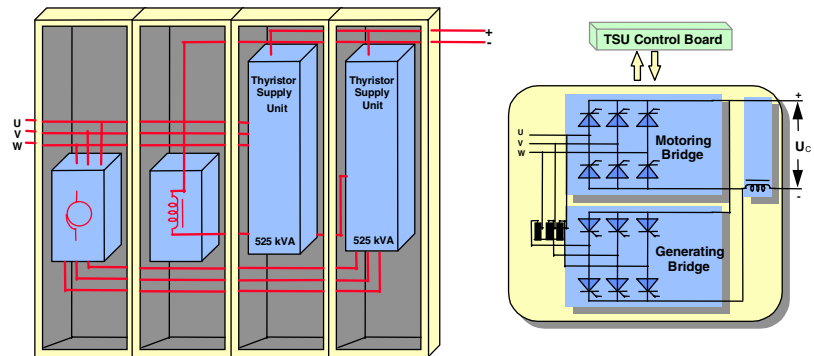

Figure 2-3 The step-up transformer fits inside the cabinet with ratings up to 525 kVA.

IGBT Supply Section

The IGBT supply section is functionally divided into four parts: Auxiliary Control Unit (ACU), Incoming Unit (ICU), Filter Unit (FIU) and IGBT Supply Unit (ISU).

Overall View

The figure below shows the layout of ACS 600 MultiDrive with the ISU. The main components typically included in the supply section are drawn using schematic symbols.

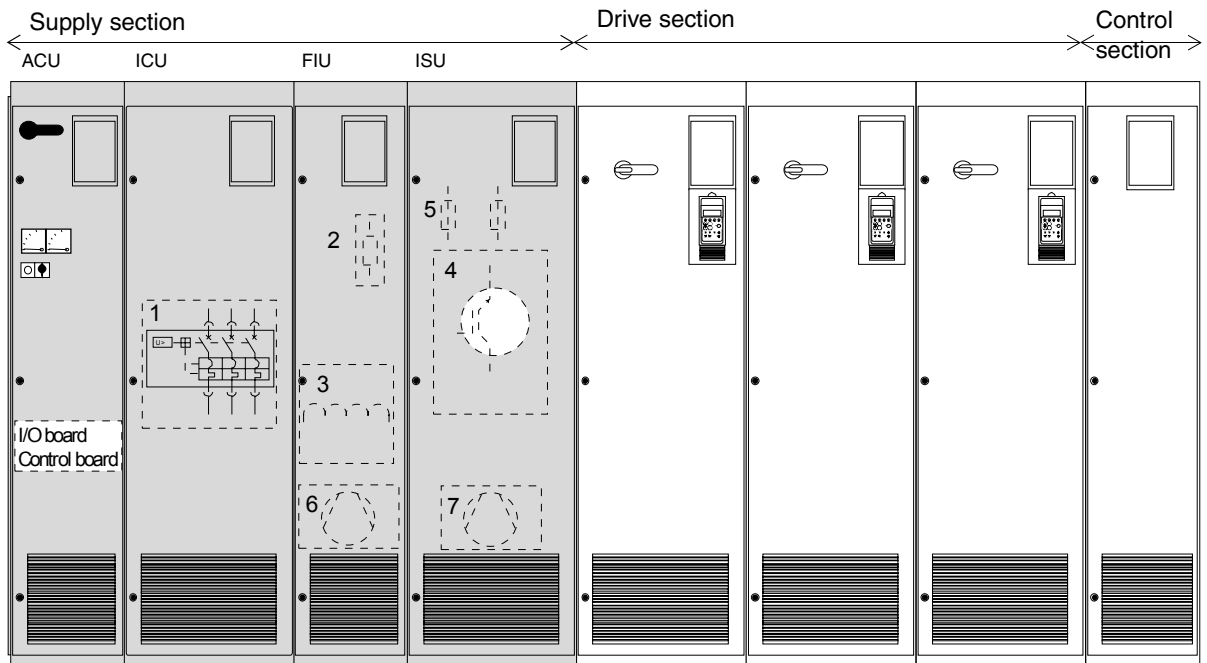

| Unit | Description | No. |
|------|--|-----|
| ACU | 230 VAC (115 VAC) auxiliary circuit equipment (e.g. starting switch, emergency stop switch, relays, protective circuit breakers for 230 VAC circuits). ISU I/O board and control board | - |
| ICU | Main disconnecter and fuses (fuse-switch) + main contactor or Main breaker (including: disconnecting device, load current on/off switch, long term thermal protection, instantaneous magnetic protection) | 1 |
| FIU | Charging circuit resistors | 2 |
| | AC choke | 3 |
| | AC choke cooling fan | 6 |
| ISU | IGBT Supply Unit | 4 |
| | DC fuses | 5 |
| | Converter cooling fan | 7 |

Auxiliary Control Unit (ACU)

The design of the Auxiliary Control Unit is the same as in the diode supply section. See the [Auxiliary Control Unit \(ACU\)](#) under *Diode Supply Section*.

Exception: The ISU control board and I/O signal interface board are in the ACU, not inside the ISU module.

Incoming Unit (ICU)

The Incoming Unit includes supply cable terminals, the main disconnecting and switching equipment and fuses.

The table below shows the alternative components available for a supply section including an IGBT Supply Unit (ISU).

| Equipment | Converter Module Size | | |
|--------------------------------|-----------------------|----------------------|----------------------|
| | R8i, R9i, R10i | R11i, 2xR11i, 4xR11i | R12i, 2xR12i, 4xR12i |
| Fuse switch (OESA) + Contactor | All types | - | - |
| Air circuit breaker (SACE) | - | All types | All types |

PDM-code: 00018306.xls - Rev F

For the ICU circuit diagrams see the [Incoming Unit \(ICU\)](#) under *Diode Supply Section*. The ICU circuit diagrams for the DSU supplies are valid for the ISU supplies considering the following exceptions:

1. No load switch is available.
2. The main fuses are outside the converter module:
 - For modules R8i, R9i and R10i the fuse switch is equipped with ultrarapid fuses.
 - For modules R11i and R12i the ultrarapid fuses are located in the filter unit.

IGBT Supply Unit (ISU) The ISU is a four-quadrant switching-mode converter. The converter consists of an IGBT bridge which forms controlled DC voltage from the supply network AC voltage and vice versa. The hardware is equal to the inverter hardware.

The AC current of the ISU is nearly sinusoidal at a unity power factor. In addition, the power flow through the converter is reversible.

Main Circuit Diagram A diagram of the main circuit of the IGBT supply is shown below.

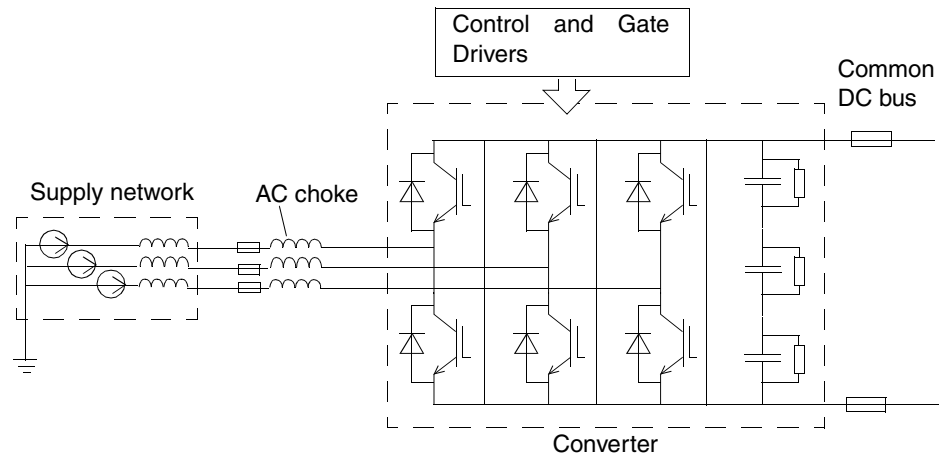

Control The control and modulation is based on the Direct Torque Control (DTC) method typically used in ACS 600 motor control. Two line currents and DC link voltage are measured and used for the control. The boards are similar to the boards of the inverter.

Harmonics IGBT Supply Unit does not generate characteristic current/voltage overtones the way a traditional 6- or 12-pulse bridge does, because of the sinusoidal waveform of the line current. The typical spectrum of the line current and line-to-line voltage harmonics is quite wide, but there are no high individual components.

ISU and DSU in Parallel In applications where the motoring power is considerably higher than the braking power and the braking lasts only short time periods, a Diode Supply Unit can be connected in parallel with an IGBT Supply Unit.

The parallel configuration is allowed only with a supply transformer equipped with two secondary windings.

Chapter 3 – Drive Sections

A drive section includes one to three inverters depending on the inverter power rating.



Figure 3-1 A 320 kVA / 500 V drive section

As a standard the inverters are protected with fuses. An optional disconnecting switch can be selected to disconnect the inverter from the DC supply.

The inverter main circuit includes DC capacitors, discharging resistors, clamping capacitors and six Insulated Gate Bipolar Transistors (IGBTs).

Inverter Module Frame Sizes

Inverter modules are installed into cubicles depending upon the physical size of the module. The frame size are: R2i, R3i, R4i, R5i, R6i, R7i, R8i, R9i, R10i, R11i or R12i.

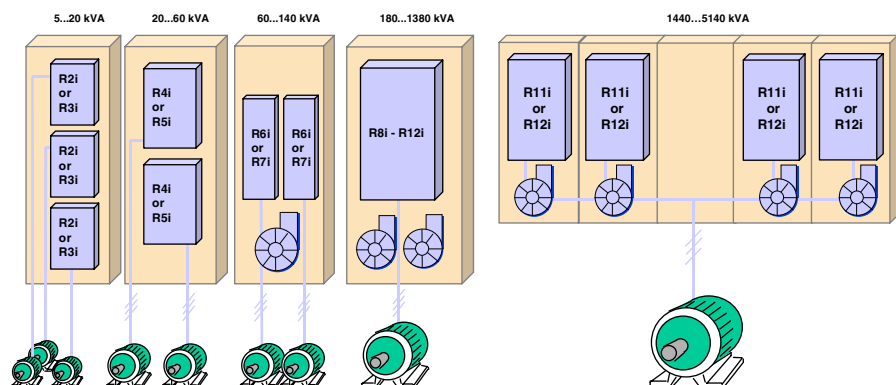

Figure 3-2 Inverter module configurations

Single R2i - R5i Units

Power ratings:

- 5 - 50 kVA, 400 VAC range
- 6 - 60 kVA, 500 VAC range
- 9 - 50 kVA, 690 VAC range

DC cooling fans are used to transfer the heat losses outside. They are located inside the module.

Single R6i - R12i Units

Power ratings:

- 60 - 1120 kVA, 400 VAC range
- 70 - 1380 kVA, 500 VAC range
- 60 - 1380 kVA, 690 VAC range

AC cooling fans are used to transfer the heat losses outside inverter modules. The fans are used for maximum cooling efficiency with fast replacement times (separate fan modules).

Parallel Units

Power ratings:

- 1440 - 2820 kVA, 400 VAC range
- 1760 - 3450 kVA, 500 VAC range
- 1710 - 5140 kVA, 690 VAC range

Up to four R11i or R12i inverter units can be connected in parallel to extend the power range. Motor outputs of the parallel inverter units are connected together with an AC bus or connected together in the motor end.

Drive Control

There is one Drive Control Unit, NDCU, for an inverter. NDCU contains the Application and Motor Control Board, NAMC and a Standard I/O Board, NIOC. The NAMC controls the inverter. With parallel inverter modules, an optical branching distributes the IGBT control signals.

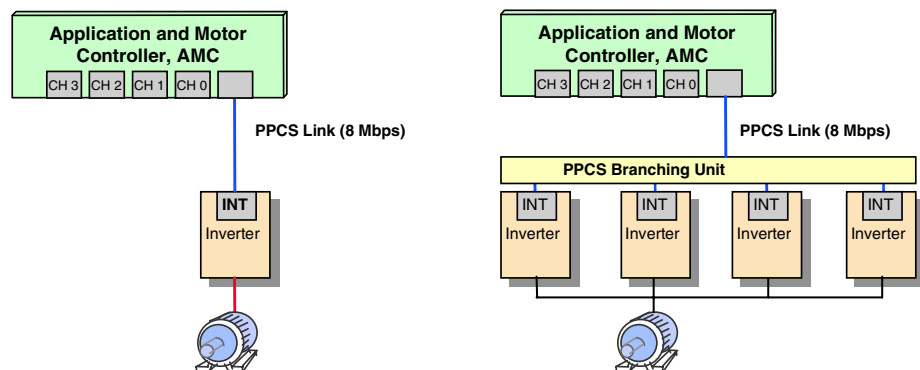

Figure 3-3 Control of single and parallel inverter units

The power supply of the Drive Control Unit is internal to the DC bus. This eliminates the need for an external power supply and allows operation to be independent of the AC supply.

Optional Features

| | |
|--|---|
| <i>Disconnect Switch with Charging Control</i> | Available options for the drive sections are provided in order to give flexibility to the ACS 600 MultiDrive. The customer can choose the preferred configuration with options. |
| | When disconnection of a single drive section is needed without opening the main switch of the incoming section, an optional DC switch can be provided instead of the standard fuse base. |
| | In thyristor and diode supply units, the common DC bus is charged in order to limit the in-rush of current during power-up. The drive units can have this feature as an option. This is necessary when a drive unit has a disconnect switch which removes it from the common DC bus connection. |
| <i>External Control Power Supply</i> | As a standard, the 24 VDC power supply for powering the control boards of a drive unit is from the common DC bus supply voltage. |
| | As an option, a 24 VDC power supply with 115 or 230 VAC input voltage is available. This is necessary when the user wants to configure the software or perform various tests without the DC bus powered. Data loggers can also be secured with an UPS system. |
| <i>Prevention of Unexpected Start-up</i> | For personal safety, operator can have a switch which prevents the unexpected start-up of the drive while servicing the production machine. |
| | Prevention of unexpected start-up switch disconnects the power from boards that give control pulses to the inverter power semiconductors. Thus it is impossible for the power stage to produce an AC voltage needed to rotate the motor. |
| <i>Control Panel</i> | See Chapter 5 – Control Section and User Interfaces / Drives Control Panel CDP 312 . |
| <i>LED Panel</i> | See Chapter 5 – Control Section and User Interfaces / LED Monitoring Display . |
| <i>Fieldbus Adapter Modules</i> | See Chapter 6 – Process Control / Fieldbus Adapter Modules . |
| <i>Analogue I/O Extension Module</i> | See Chapter 6 – Process Control / NAIO-03 (Analogue I/O Extension Module) , optional. |
| <i>Digital I/O Extension Module</i> | See Chapter 6 – Process Control / NDIO-02 (Digital I/O Extension Module) , optional. |

Chapter 4 – Braking Section

Typically the ACS 600 MultiDrive is equipped with the optional braking section if:

- High capacity braking is needed and the ACS 600 MultiDrive cannot be equipped with a regenerative supply section.
- A backup for the regenerative supply section is needed.

The braking sections include a preselected chopper(s), or chopper(s) and resistor(s).

Overall View

The overall view of the ACS 600 MultiDrive equipped with a braking section is shown below.

Both in ACA 621 and 622 Braking Sections:

- 1 DC fuses
- 2 Attenuator
- 3 Braking chopper (NBRA-6xx)
- 5a Cooling fan
- 6a Chopper cabinet

Only in ACA 622 Braking Sections:

- 4 Braking resistors (SAFUR)
- 5b Cooling fan
- 6b Resistor cabinet

Configuration of Parallel Cubicles

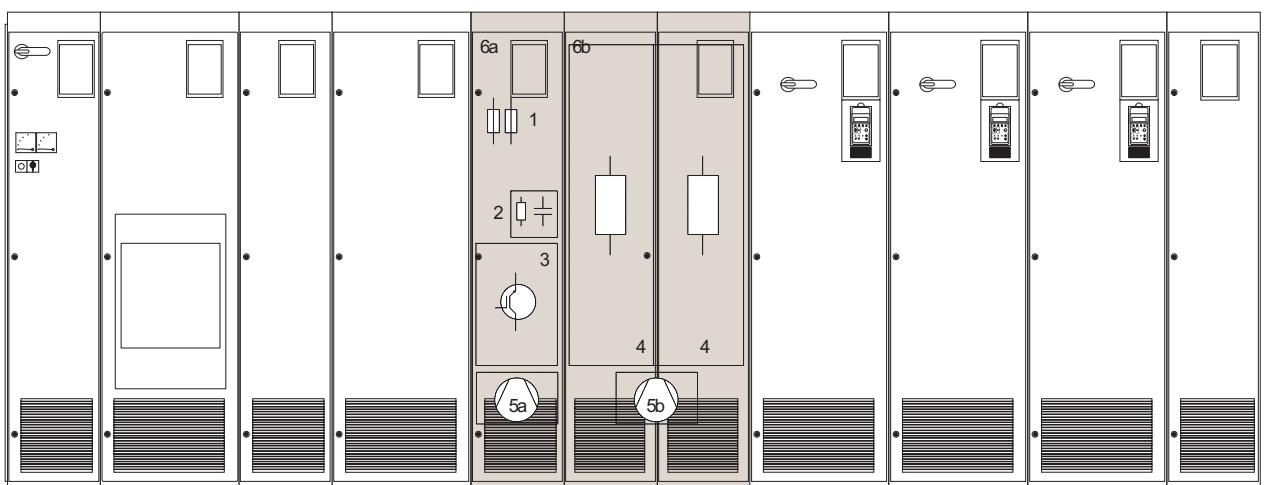
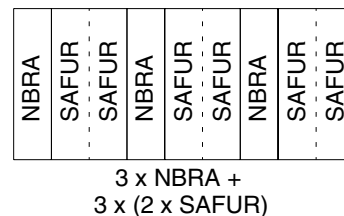
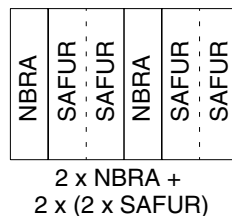

Attenuator

The attenuator damps the intermediate circuit voltage spikes at the chopper input terminals thus decreasing the chopper stress.

Braking Resistors

The braking resistors dissipate the surplus energy conducted by the choppers.

ACA 622 braking sections are equipped with the braking resistors. ACA 621 braking sections must be equipped with the braking resistors by the user.

Braking Chopper

The chopper connects the braking resistor to the intermediate circuit whenever the voltage in the intermediate circuit (DC bus) exceeds the maximum limit.

Energy consumption by resistor losses lowers the voltage until the resistor can be disconnected. The energy generated by the motor during a fast deceleration of the drive typically causes the voltage to rise in the intermediate circuit.

The chopper control board supervises system status and detects failures such as:

- braking resistor and resistor cable short circuits
- chopper (IGBT) short circuit
- chopper control board failure
- chopper and resistor overtemperature

Braking Section Selection Tool

A Microsoft Excel based tool for selecting the braking section is available. Please ask your local ABB representative.

Chapter 5 – Control Section and User Interfaces

Control Section Overview

The ACS 600 MultiDrive line-up can be equipped with the optional control section for housing local process control equipment such as Advant Controller AC80, panels, I/O units, modems, fieldbus adapters, communication link branching units, etc. The figure below shows the ACS 600 MultiDrive with the control section.



User Interfaces

The ACS 600 MultiDrive offers the user numerous possibilities to monitor, control and program.

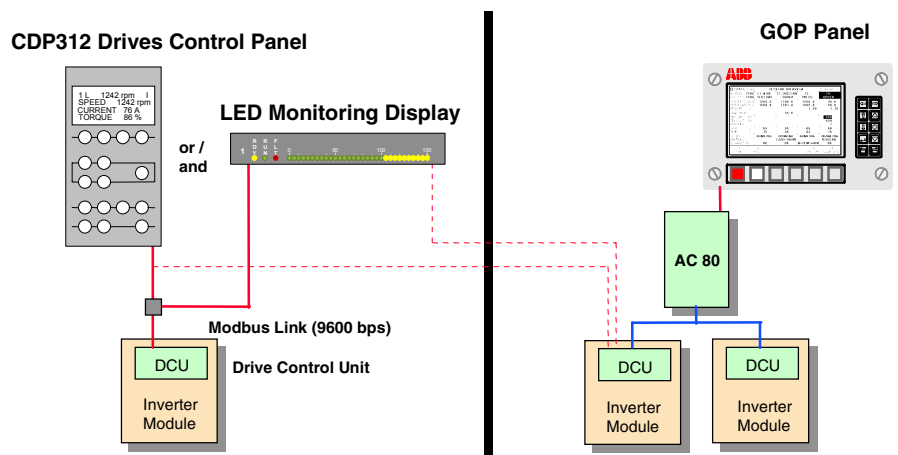

Figure 5-1 Man-machine interfaces of ACS 600 MultiDrive

- LED Monitoring Display**
- Three status indicators: Run, Ready, and Fault
 - 0-150% selectable parameter indicator

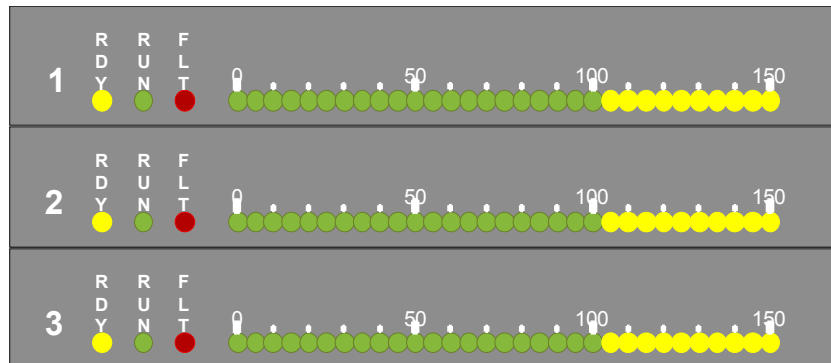

Figure 5-2 One cubicle can contain a maximum of three LED monitoring displays, one per inverter

The LED monitoring display is a door mountable unit which is used for monitoring the ACS 600 inverter modules. It contains three status indicators: ready, run, and fault, and a LED bar display with the scale of 0 - 150%. The LED bar displays the parameter level of the inverter which is selected by the software on the NAMC board.

The display is connected to the NAMC board through a standard Modbus link.

**Drives Control Panel
CDP 312**



- Two status LEDs (on the panel mounting platform)
- Four lines x 20 character backlit LCD display

Functions available:

- Enter start-up parameter data
- Local control with reference setting
- Display actual values
- Display and adjust parameters
- Display information of five most recent faults and reset
- Upload/download complete parameter settings from one drive to another.

The panel can be attached directly to the door of the cabinet, the cover of the drive unit, or on a control desk.

**Graphical Operating
Panel (GOP)**

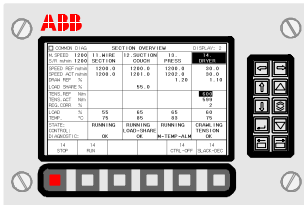

- 16 programmable control keys
- High-resolution electroluminescent display, 640 x 640 pixels
- Display size: 192 mm x 120 mm
- Outer dimensions: 330 mm x 220 mm x 68 mm (w x h x d)
- Power Consumption: 24 VDC, 0.8 A
- Process Interface: RS 485, multidrop, 19.2 kbit/s
- Weight: 3 kg
- Protected to IP 65

Chapter 6 – Process Control

General Information

Advanced interfacing, utilising data set communications and open programming methods, allow the ACS 600 MultiDrive to be connected and tightly co-ordinated with ABB and non-ABB control systems. All of the ABB process controllers share a common programming language and tool, the AdvaBuild Function Chart Builder, which enables reusable code and future expandability to be easily taken into account.

Automation

ABB's Advant Open Control System (Advant OCS) can be utilised with large production lines. The Advant OCS comprises several scalable process controllers, the Advant Controllers. They provide hundreds of centralised analogue and digital I/O points which can be further expanded up to thousands of I/O points using distributed control.

The Advant automation products provide a range of top-level controllers – such as AC 80/110/410/450/460, MasterPiece 200/1, Advant Station 500 – which complement the ACS 600 MultiDrive for large systems. (These controllers are defined in greater detail in the respective product manuals.)

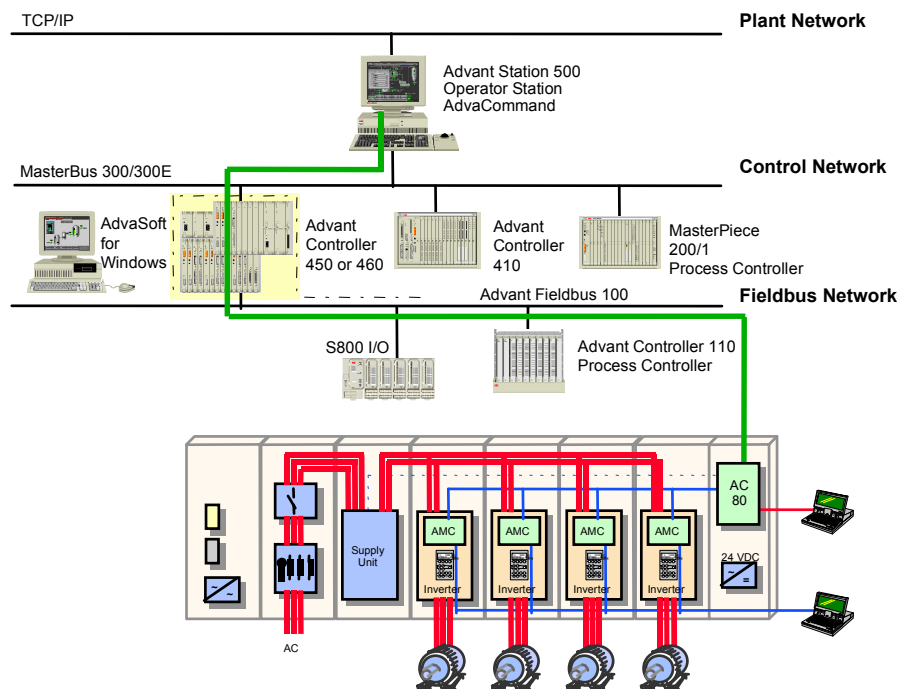

Figure 6-1 Event handling via ABB process controllers

*Advant Fieldbus 100
(AF100)*

Advant Controllers employ the Advant Fieldbus 100 (AF 100) communication bus. It is a high speed communication link intended for communication between an Advant Controller 400 Series, Advant Controller 110, Advant Controller 80, and S800 I/O Stations, AdvSoft for Windows, and other equipment adapted for the bus.

The AF 100 is specifically designed for real-time applications. It features reliable, cyclic data transfer as well as event-driven background transfer of service data. The AF 100 features a master scheme, distributed to one or several communication interfaces on the bus. Such an interface is called the bus administrator.

Inputs/Outputs

The ACS 600 MultiDrive utilises numerous I/O devices to collect and send process information. When the Advant Controller 80 (AC 80) solution is used, the I/O modules connected to it collect the process information that is required to control the drives correctly. The inverter unit I/O is mainly used for inverter-specific safety features such as emergency stop, start inhibition and motor temperature supervision with a Pt100 sensor.

With the AC 80, also the inverter unit I/O can be used to collect process information. However, this information must first be sent to the AC 80 and then again back to the inverter units to control the motors.

Advant Controller 80 (AC 80)

The ACS 600 MultiDrive is integrated to an Advant OCS by using the Advant Controller 80 (AC 80) which is specially designed for control of drives. The AC 80 can also be used independently, or connected to another AC 80 via an AF100 bus. In a configuration like this, an additional bus administrator device, such as a CI627A Communication Interface, is required.

The AC 80 features a system control with a processing unit capable of handling the process control and peripheral devices. The AC 80 is a single processing unit which has various I/O options to fully integrate the dedicated drives controller with both drives and upper level control systems.

Figure 6-2 gives an overview of the connections of the AC 80, followed by a brief description of each I/O link. These are detailed further in the *AC 80 User's Manual* (EN 3BFE 64116487) and the *S800 I/O User's Guide* (EN 3BSE 008 878).

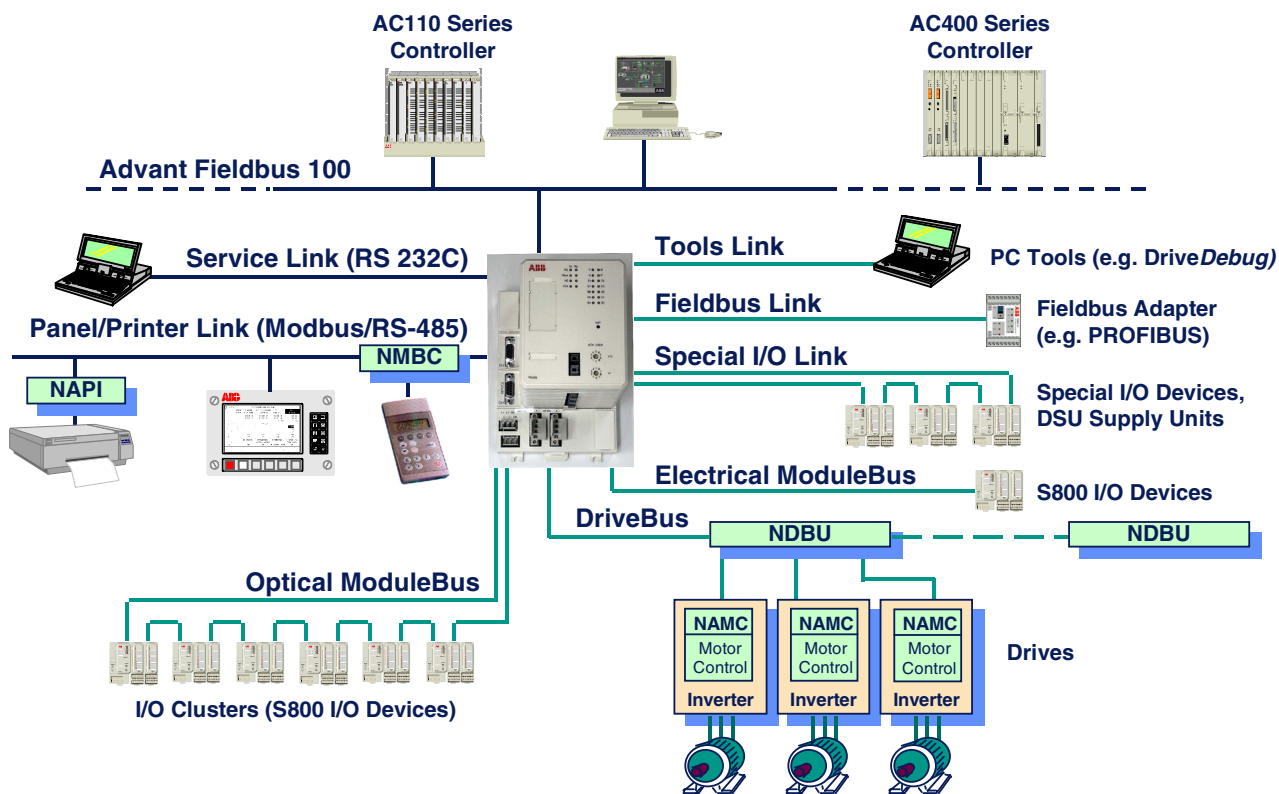

Figure 6-2 The connections of the AC 80

DriveBus The optical DriveBus link can be used for controlling 12 NAMC-based drives or inverter units. The connection of multiple drives requires the use of a DDCCS branching unit (NDBU), which enables the construction of a logical bus with physical star topology. Branching units can be chained together.

The DriveBus link can employ both plastic and HCS fibre optic cables. The use of HCS cables enables longer distances; the maximum length of the bus is 15 m for plastic cable, 200 m for HCS cable.

DriveBus uses a communication speed of 4 Mbit/s, with a message cycle time of 50 μ s (asynchronous). The specified transfer capability is 16 data sets (8 data sets in each direction) per millisecond. One data set consists of three 16-bit words.

Communication delays are shown below.

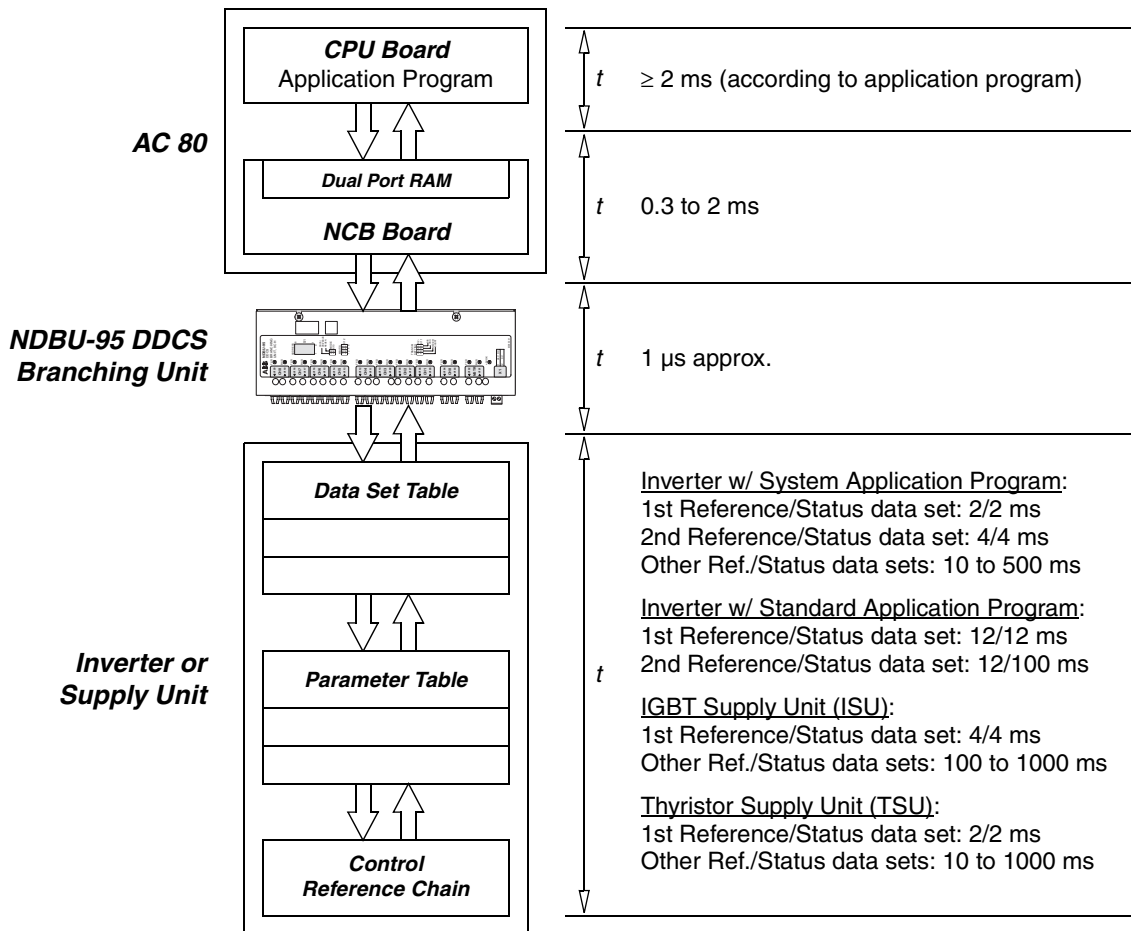

Figure 6-3 Signal delays between the AC 80 and NAMC-based inverter/supply units on DriveBus

ModuleBus ModuleBus is used for connecting I/O devices (or NAMC-based inverters). The AC 80 and the devices connected to ModuleBus form an I/O station. One I/O station can handle up to 384 digital I/O signals or 192 analogue I/O signals.

ModuleBus is divided into electrical and optical busses which are logically the same bus. The electrical ModuleBus link is made up of S800 I/O devices installed side by side on the same mounting rail as the AC 80 itself. Extension cables may also be used to install I/O devices of different types onto different mounting rails. The maximum length of the bus is 2 metres.

The optical ModuleBus link is constructed as a ring on the optional TB810/811 Optical Port, plugged onto the AC 80. NAMC-based drives can be connected directly to the link, while S800 I/O devices can be connected using TB820 ModuleBus Modems. The maximum number of S800 devices and drives on the optical ModuleBus link is 12.

S800 I/O devices are distributed modular I/O units which communicate with Advant controllers over an AF100 bus. Each S800 I/O device consists of a module termination unit (MTU) and an I/O module installed on it. Table 6-1 below shows the typical S800 I/O module types used with the AC 80. For more information on the different S800 I/O devices available, refer to the *S800 I/O User's Guide* (EN 3BSE 008 878).

Communication delays are shown in Figure 6-4.

Table 6-1 Typical S800 I/O modules used with the AC 80

| Module Type | Channels | Channel Type |
|-------------|----------|------------------------------------|
| AI810 | 8 | 0 to 20 mA, 0 to 10 V |
| AI820 | 4 | ± 20 mA, ± 10 V, ± 5 V |
| AI835 | 8 | for Thermocoupling, mV |
| AO810 | 8 | 0 to 20 mA, 0 to 10 V |
| AO820 | 4 | ± 20 mA, ± 10 V, ± 5 V |
| DI810 | 16 | 24 V DC (current sink) |
| DI814 | 16 | 24 V DC (current source) |
| DI820 | 8 | 120 V AC |
| DI821 | 8 | 230 V AC |
| DO810 | 16 | 24 V DC (current sourcing) |
| DO814 | 16 | 24 V DC (current sinking) |
| DO820 | 8 | 230 V (relay) |

Special I/O Link This DDCS-protocol, fibre optic ring can be used for connecting up to eight I/O devices to the AC 80. The transmission speed of the Special I/O connection is 4 Mbit/s, and the maximum transfer capability 4 data sets (2 data sets in each direction) per millisecond. One data set consists of three 16-bit words.

The Special I/O connection can be used with the following devices:

NBIO-21 (Basic I/O Unit 2)

- Two analogue inputs, 0...2 V, 0...10 V, -10...+10 V or 0...20 mA. Resolution: 12 bits, except for -10...+10 V (11 bits + sign bit). Hardware filtering time constant: 10 ms
- Two analogue outputs, -10...+10 V or 0...20 mA. Resolution: 12 bits. Hardware filtering time constant: 1 ms
- Three digital inputs, 24 VDC or 115/230 VAC. Hardware filtering time constant: 8 ms. Individually isolated
- Two relay outputs. Switching capacity: 6 A at 24 VDC (resistive load), 0.2 A at 120 VDC (resistive load), 6 A at 250 VAC. Maximum continuous current: 2 A

NBIO-31 (Basic I/O Unit 3)

- Four digital inputs, 24 VDC or 115/230 VAC. Hardware filtering time constant: 8 ms. Individually isolated
- Three relay outputs. Switching capacity: 6 A at 24 VDC (resistive load), 0.2 A at 120 VDC (resistive load), 6 A at 250 VAC. Maximum continuous current: 2 A

NWIO-01 (Watchdog and I/O Module)

- Two digital inputs, 24 VDC or 115/230 VAC. Hardware filtering time constant: 8 ms or 1 ms (selectable). Individually isolated
- Two relay outputs. Switching capacity: 8 A at 24 VDC (resistive load), 0.4 A at 120 VDC (resistive load), 2000 VA at 250 VAC. Maximum continuous current: 2 A
- 1 watchdog timer. Time constant: 1 s or 0.2 s. Enabled with switch. Connected to relay output DO2.

NAIO-03 (Analogue I/O Extension Module). See *Chapter 6 – Process Control / NAIO-03 (Analogue I/O Extension Module), optional.*

NDIO-02 (Digital I/O Extension Module). See *Chapter 6 – Process Control / NDIO-02 (Digital I/O Extension Module), optional.*

NTAC-02 (Pulse Encoder Interface Module). See *Chapter 6 – Process Control / NTAC-02 (Pulse Encoder Interface Module), optional.*

NPCT-01 (Pulse Counter and Timer Unit)

- Two encoder inputs, single-ended or differential, A, B, Z, \bar{A} , \bar{B} , \bar{Z} . Maximum signal frequency: 300 kHz. Signal level/power supply for encoder: 15 or 24 VDC. Speed feedback resolution: 24 bits. Position feedback resolution: 16 bits
- Two programmable, 24-bit-wide counters
- Four digital inputs, 24 VDC. Individually isolated
- Four digital outputs, open emitter/collector. Maximum output voltage: 30 VDC. Maximum output current: 100 mA. Individually isolated.

NDSC-01, the control board of a Diode Supply Unit (DSU).

Fieldbus Link

This DDCS-protocol, 4 Mbit/s fibre optic link can be used for connecting the AC 80 to an open fieldbus. The AC 80 primarily supports *extended mode* fieldbus adapters. Extended mode adapters are specifically designed for use with the AC 80, and are suitable for transferring large amounts of data.

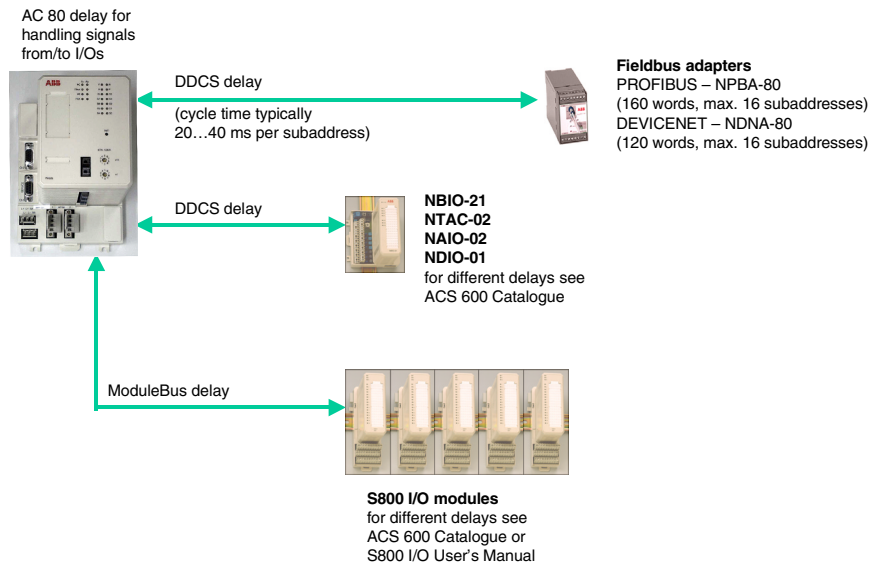

Figure 6-4 Signal delays between I/O devices on ModuleBus, Special I/O and Fieldbus Link, and the AC 80

For more information on extended mode adapters, see their respective protocol manuals. For information on connecting the AC 80 to other fieldbus systems, contact an ABB representative.

Table 6-2 Available extended-mode fieldbus adapter modules

| Type | Protocol | Manual Code (English) |
|---------|-------------|-----------------------|
| NDNA-80 | DeviceNet | 3BFE 64336886 |
| NPBA-80 | PROFIBUS-DP | 3BFE 64248260 |

Panel/Printer Link The panel/printer connector is a Modbus-protocol RS-485 interface for up to 8 devices. The panel/printer link can be operated in two modes (only one of which can be active at a time):

Panelbus mode: for connection of Slave devices such as the CDP 80 Control Panel or a Centronics-interface alarm printer.

MultiVendor mode: for connection of a Man/Machine Interface (MMI) – such as the Graphical Operator Panel (GOP) from ABB Industry Pulp & Paper – or external Modbus-protocol Slave or Master devices.

See Figure 6-5.

Table 6-3 Devices connectible to the Panel/Printer Link

| | | MultiVendor Mode | | Panelbus Mode |
|--|----|---|--|--|
| Required Application Programming Elements: | DB | MVICHAN, MVINODE, MVB | | PANBUS |
| | PC | none | | PANC (for CDP 80), PRTCON (for printer), MODR and MODW (for other devices) |
| Modbus Mode: | | Master | Slave | Master |
| Connectible Devices: | | MMI (e.g. GOP) and/or slave AC 80s and/or other slave devices | One master device (e.g. PC or master AC 80) | CDP 80 panel and/or NAPI-01 printer interface and/or other slave devices |

Tool Link This DDCS-protocol fibre optic link can be used for connecting the AC 80 to a PC equipped with e.g. DriveDebug. The PC must be equipped with a NPCM-01 PCMCIA/DDCS interface or an NISA-03 ISA/DDCS interface. For more information on PC tools, see [Chapter 7 – PC Tools](#).

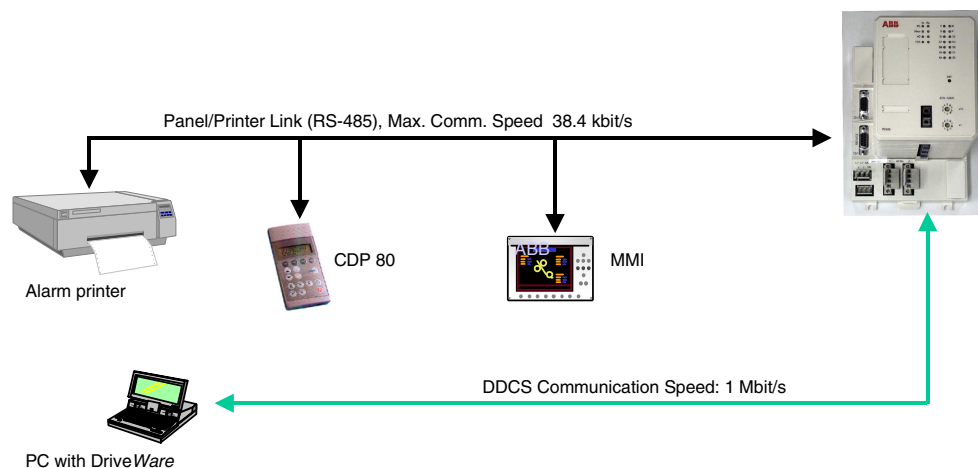

Figure 6-5 Communication speeds on the Panel/Printer and Tool links

*Related Devices***CI626A/CI627A AF 100 Bus Administrators**

The CI626A and CI627A are stand-alone AF 100 bus administrators that can be used when no other administration-capable devices are present on the AF 100 bus. (For example, AC 80 units connected by an AF 100 bus require an additional bus administrator.) The CI626A has coaxial AF 100 connectors while the CI627A has twisted-pair screw connectors.

NDBU-85/NDBU-95 (DDCS Branching Units)

While DDCS data buses normally have a ring topology, the NDBU branching units can be used to construct a star communication configuration, thus allowing the disconnection of one or more ACS 600 inverter modules without disrupting the entire system.

NOCR-01 (Optical Converter/Repeater Unit)

The NOCR can be used as a converter between different types of optical components. In addition, two NOCR units can be used to extend the maximum length of an optical DDCS link up to 1.2 km. The long-distance link between the NOCR units uses Hard Clad Silica (HCS) or Glass Optical Cable (GOF).

NMBC-01 (Modbus Termination Unit)

This board is used as a connection/termination unit on the panel/printer link of the AC 80. The NMBC provides a terminal block for a twisted-pair bus (to a MMI, or the NAPI Alarm Printer Interface), as well as jacks for a CDP 80 control panel and an NDPI-21 control panel interface.

NAPI-01 (Alarm Printer Interface)

This board interfaces a Centronics alarm printer with the twisted-pair bus provided by NMBC-01. The board has two bus cable connectors to enable an intermediate connection.

Application and Motor Controller (NAMC)

The Application and Motor Controller (NAMC) is used in inverter units throughout the whole ACS 600 product family. The NAMC utilises a high speed digital signal processor, ASIC technology and optical high speed communication channels. The NAMC contains the unique DTC motor control as well as the application program. ACS 600 MultiDrive inverter units are usually equipped with the System Application Program, but other application programs of the ACS 600 family can be selected as well, or a custom application program can be created using the Function Chart Builder.

As standard, the NAMC and standard I/O board (NIOC) are packaged into one Drive Control Unit (NDCU)

Figure below presents the communication links of the NAMC board.

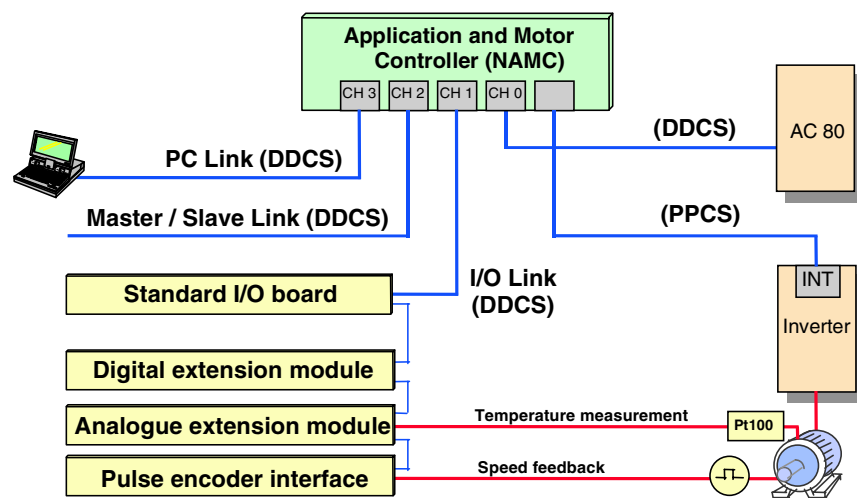

Figure 6-6 NAMC communication links

NIOC (Standard I/O Board)

- Two current analogue inputs, 0(4)...20 mA. Resolution: 10 bits
- One voltage analogue input, 0(2)...10V. Resolution: 10 bits
- Two current analogue outputs, 0(4)...20 mA. Resolution: 10 bits
- One constant voltage output, 10 V ±0.5%
- Six digital inputs, +24 V
- Three relay outputs. Switching capacity: 8 A at 24 VDC or 250 VAC, 0.4 A at 120 VDC. Maximum continuous current: 2 A

NAIO-03 (Analogue I/O Extension Module), optional

- Two analogue inputs, ±0(4)...20 mA, ±0(2)...10 V, or ±0...2 V. Resolution: in unipolar mode 12 bits; in bipolar mode 11 data bits + sign bit
- Two analogue outputs, 0(4)...20 mA. Resolution: 12 bits
- Inputs and outputs galvanically isolated from power supply and from earth
- DIN rail mountable

NDIO-02 (Digital I/O Extension Module), optional

- Two digital inputs, 110...230 VAC or 24...250 VDC
- Two relay outputs. Switching capacity: 2000 VA at 250 VAC, 8 A at 24 VDC (resistive load), 0.4 A at 120 VDC (resistive load). Maximum continuous current: 2 A
- Inputs and outputs galvanically isolated from power supply and from earth
- DIN rail mountable

NBIO-21 (Basic I/O Unit 2), optional. See *Chapter 6 – Process Control / NBIO-21 (Basic I/O Unit 2)*.

NTAC-02 (Pulse Encoder Interface Module), optional

- 15 or 24 VDC signal level and power supply for encoder
- Single ended or differential inputs
- A, B, Z, \bar{A} , \bar{B} , \bar{Z} ; A and B 90° (electrical) apart from each other
- Maximum signal frequency: 100 kHz
- Speed feedback resolution: 15 bits
- Encoder input Isolated from power supply and from earth
- DIN rail mountable

Fieldbus Adapter Modules

Fieldbus adapter modules are used for connecting an NAMC-based inverter unit directly to a fieldbus. The fieldbus adapters listed below are compatible with the ACS 600 System Application Program. For other drive application programs, check the compatibility with your ABB representative. Further information on the fieldbus adapter modules is available from the product documentation.

- AF 100 Adapter Kit (NAFA-01)
- Building Automation Adapter Module (NBAA-01)
- CANopen Adapter Module (NCAN-02)
- CS 31 Adapter Module (NCSA-01)
- DeviceNet Adapter Module (NDNA-02)
- InterBus-S Adapter Module (NIBA-01)
- LONWORKS® Adapter Module (NLON-01)
- Modbus Adapter Module (NMBA-01)
- Modbus Plus Adapter Module (NMBP-01)
- PROFIBUS Adapter Module (NPBA-02).

Chapter 7 – PC Tools

DriveWare PC Tools

The DriveWare family of PC tools includes Windows-based applications for commissioning, control and maintenance of ACS 600 drives.

DriveWindow

DriveWindow is an application designed for online commissioning and maintenance purposes. It is possible to adjust the parameters, read the actual values and control up to 255 drives with DriveWindow. It is also possible to follow trends, draw graphs and load custom-made application software to the drives.

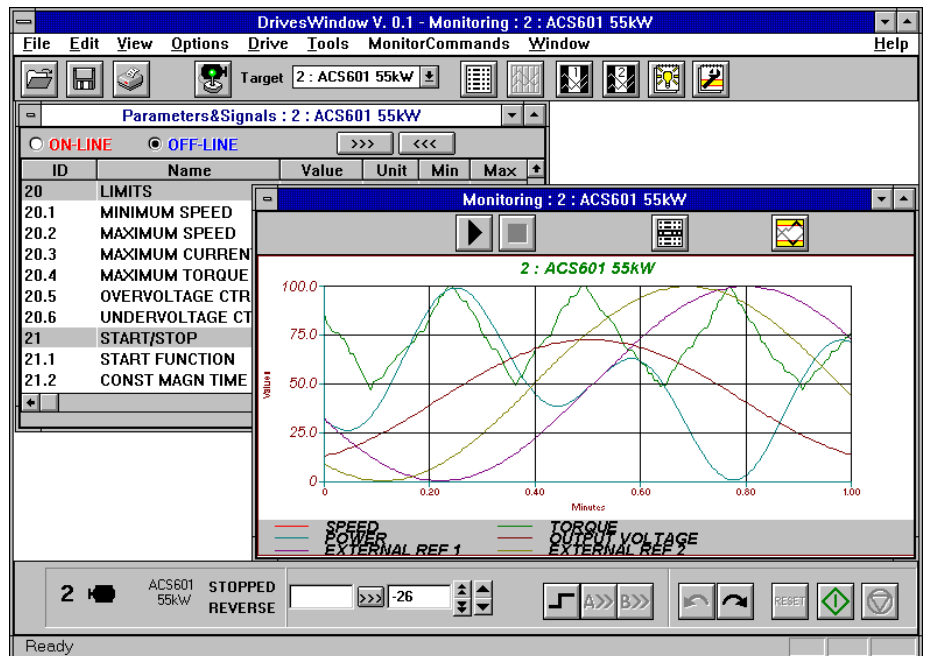

The DriveWindow kit includes:

- either an ISA/DDCS or a PCMCIA/DDCS connection kit
- a pair of fibre optic cables
- installation CD-ROM.

Multiple drives are connected in a ring. Using DDCS branching units, a more reliable star topology can also be realised.

DriveSize DriveSize is an application designed for dimensioning of motors (ABB or customer-specified AC motors), drives and transformers in a drive system. DriveSize comes with MotSize, a dimensioning tool for direct-on-line motors.

DriveSize supports the following functions:

- Ambient conditions
- Motor load types: constant power; constant torque; constant torque and power; squared torque
- Cyclic motor load types: standard duty cycles S1 - S30 and DCI - DCIV; customised duty cycles
- Motor temperature rise class and cooling class selections
- Network harmonics calculation
- Supply unit power factor and DC voltage calculation
- Numerical and graphical display of unit capabilities
- Selection of alternative motors, inverter units or supply units
- Imperial and metric units.

DriveBuilder DriveBuilder is a tool for generating bills of material, actual cabinet dimensions and electrical single-line diagrams. In addition, DriveBuilder produces system-specific customer documentation on the grounds of user input as well as information imported from DriveSize.

DriveSupport DriveSupport is a multimedia-based service tool for ABB drives. It provides actual pictures and clear instructions for troubleshooting and servicing the drive. DriveSupport also creates a maintenance record, including types of faults, operators' names, and service activities performed since start-up.

The customer can tailor DriveSupport to meet the needs of his specific process by adding his own graphics, user language, more detailed instructions, spare part numbers and contact information.

DriveLink DriveLink is an application for connecting ABB drives with PC-based monitoring systems. DriveLink is compatible with all Windows applications that support DDE (Dynamic Data Exchange), such as WonderWare Intouch®, Genesis®, Excel®, Visual Basic®, DriveSupport and Adva Command®.

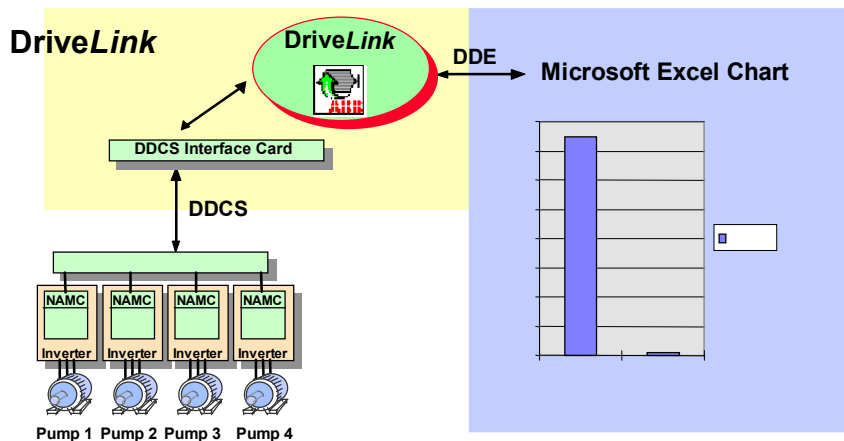

DriveDebug

DriveDebug is an advanced diagnostic tool for devices that use ABB’s DDCCS protocol. These include e.g. the Advant Controller 80 and the ACS 600. Using DriveDebug requires an ISA/DDCCS or a PCMCIA/ DDCCS interface, depending on type of computer used.

DriveDebug can be used for data logging, setting and backing up parameters, backing up the whole application program and graphical trending of actual values, application variables and/or memory locations, etc.

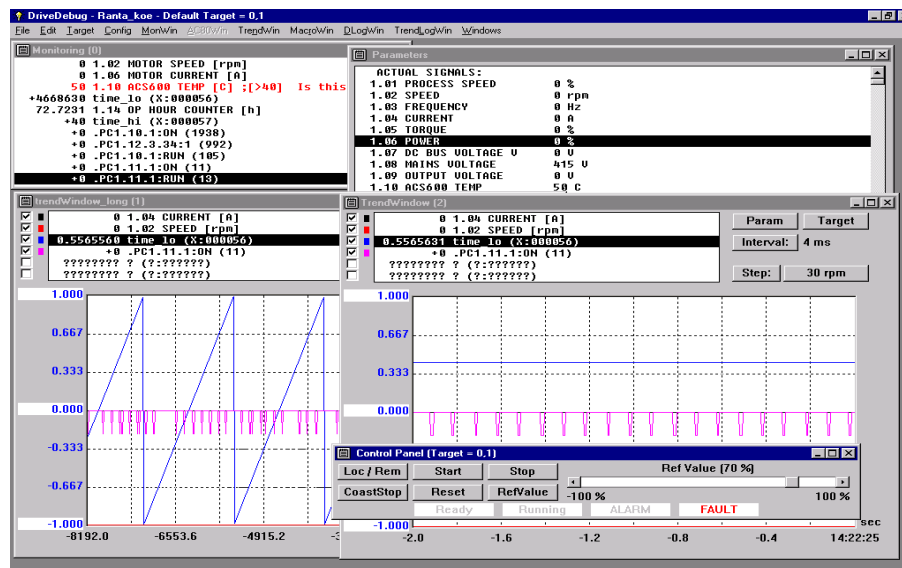

AdvaBuild for Windows

AdvaBuild for Windows is an engineering tool for creating and modifying application programs. The programming is function block orientated. The PC tool is common for products such as the NAMC (Application and Motor Controller) and the Advant Controllers.

Applications created using an older programming tool, the Function Chart Editor (FCE) can be imported.

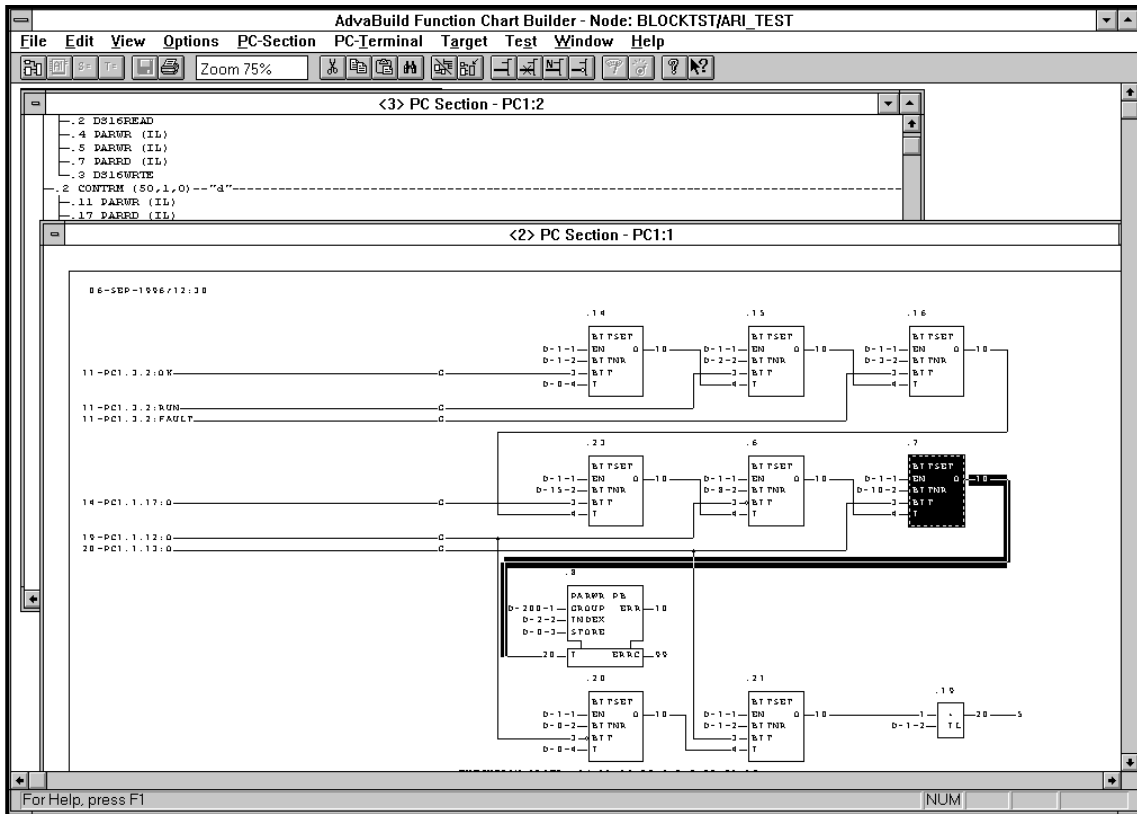



3AFY 63700151 R0325
EFFECTIVE: 8.11.2000

ABB Industry Oy

Drives

P.O.Box 184

FIN-00381 Helsinki

FINLAND

Telephone: +358 10 22 2000

Telefax: +358 10 22 22681

Internet: <http://www.abb.com/automation>