

This manual includes

- Safety Instructions
- Technical data

These Safety Instructions must be studied before storing, installing, commissioning, servicing and operating the air-cooled ACS 600 MultiDrive frequency converters.

ACS 600 MultiDrive Manuals (Air-cooled Units, English Originals)

GENERAL MANUALS

*Safety and Product Information EN 63982229

- Complete general Safety Instructions
- Technical data for DSU and TSU supplies and Drive Sections: ratings, power losses, dimensions, weights, fuses etc.

*System Description EN 63700151

- General description of ACS 600 MultiDrive

*Hardware Manual EN 63700118

- General Safety Instructions
- Hardware description of the Drive Section
- Cable selection
- ACS 600 MultiDrive mechanical and electrical installation
- Hardware commissioning of the Drive Section
- Preventive maintenance of ACS 600 MultiDrive

ACS 600 MultiDrive Control Electronics LED Indicators

EN 64289721

- LED descriptions

**Modules Product Catalogue EN 64104268

- Supply Unit components
- Drive Unit components
- Dynamic Braking Units
- DriveWare information
- Dimensional drawings
- Single line diagrams
- Auxiliary power consumption
- Master component tables

**Modules Installation Manual EN 64119010

- Cabinet assembly
- Wiring

**Grounding and Cabling of the Drive System EN 61201998

- Grounding and cabling principles of a variable speed drive system

**EMC Compliant Installation and Configuration for a Power Drive System EN 61348280

- * Included with cabinet-assembled systems only
- ** Included in Modules deliveries only

SUPPLY SECTION MANUALS (depending on the supply type one of these manuals is included in the delivery)

Diode Supply Sections User's Manual (DSU) EN 61451544

- DSU specific Safety Instructions
- DSU hardware and software descriptions
- DSU commissioning
- Earth fault protection options

Thyristor Supply Sections User's Manual (TSU) EN 64170597

- TSU operation basics
- TSU firmware description
- TSU program parameters
- TSU commissioning

IGBT Supply Sections User's Manual (ISU) EN 64013700

- ISU specific Safety Instructions
- Main components of ISU
- ISU ratings
- ISU power losses
- ISU dimensions and weights
- ISU fuses
- ISU program parameters
- Earth fault protection options

FIRMWARE MANUALS FOR DRIVE APPLICATION PROGRAMS

(appropriate manual is included in the delivery)

System EN 63700177

- Commissioning of the System Application Program
- Control Panel use
- Software description
- Parameters of the System Application Program
- Fault tracing
- Terms

Application Program Template EN 63700185

- Commissioning of the Drive Section
- Control Panel use
- Software description
- Parameters
- Fault tracing
- Terms

Standard EN 61201441

- Control Panel use
- Standard application macros with external control connection diagrams
- Parameters of the Standard Application Program
- Fault tracing
- Fieldbus control

Note: a separate Start-up Guide is attached

Crane Drive EN 3BSE 011179

- Commissioning of the Crane Drive Application Program
- Control Panel use
- Crane program description
- Parameters of the Crane Drive Application Program
- Fault tracing

CONTROL SECTION MANUALS (delivered with optional Control Section)

Advant Controller 80 User's Manual EN 64116487

- AC 80 hardware and connections
- AC 80 software
- Programming
- Diagnostics

Advant Controller 80 Reference Manual PC Elements EN 64021737

- Description of PC and DB elements

Advant Controller 80 Reference Manual TC Elements EN 64331868

- Description of TC elements

BRAKING SECTION MANUAL (delivered with optional Braking Section)

ACA 621/622 Braking Sections User's Manual EN 64243811

- Installation, Start-up, Fault tracing, Technical data
- Dimensional drawings

MANUALS FOR OPTIONAL EQUIPMENT (delivered with optional equipment)

Fieldbus Adapters, I/O Extension Modules, Braking Choppers etc.

- Installation
- Programming
- Fault tracing
- Technical data

ACA 6xx Sections
3 to 4300 kW

Safety and Product Information

efesotomasyon.com

3AFY 63982229 R0125 REV D

EFFECTIVE: 1.12.2000
SUPERSEDES: 15.10.1999

Table of Contents

ACS 600 MultiDrive Manuals (Air-cooled Units, English Originals)

Table of Contents

Safety Instructions

Overview	1
CAUTION!	1
Note:	1
Operation	1
Installation and Maintenance Safety	2
Starting TSU or DSU	4
ACA 635 (ISU) Supply	5
Supply Connections	5
Earth Fault Protective Function	6
Emergency Stop Devices	6
Immediate Removal of Power (Category 0)	7
Controlled Emergency Stop (Category 1)	7
Restart	7
Prevention of Unexpected Start	7
Motor Connections	8
Pulses in the Drive Output	8
Power Factor Compensation Capacitors	12
Components Connected to Digital/Analogue Inputs	13
EMC	13
Fibre Optic Cables	14
Cooling	14
Mechanical Installation	15

ACS 600 MultiDrive – Technical Data

Abbreviations	A-1
Supply Section Tables	A-2
Notes	A-2
Ratings 380...415 V	A-3
Ratings 380...500 V	A-4
Ratings 525...690 V	A-5
Ratings 830 V	A-6
Autotransformer Data	A-7
Dimensions and Weights 400 V	A-8
Dimensions and Weights 500 V	A-9
Dimensions and Weights 690 V	A-10
Dimensions and Weights 830 V	A-11

Drive Section Tables	A-12
Notes	A-12
Ratings 400 V	A-13
Ratings 500 V	A-14
Ratings 690 V	A-15
Braking Section Tables	A-16
Abbreviations and Notes	A-16
Ratings	A-17
Dimensions, Air Flow and Noise	A-18
Cabinet	A-19
IP 54 R Air Outlet Duct Connection	A-19
Input Power Connection	A-20
Motor Connection	A-20
Efficiency and Cooling Method	A-22
Ambient Conditions	A-22
Fuses	A-24
AC Fuses	A-24
Branch Fuses	A-25
Supply DC Fuses	A-26
Drive Unit DC Fuses	A-27
Braking Section DC Fuses	A-28
Power Cable Entries	A-29
Tightening Torque	A-29
Marking	A-29
Diode Supply Sections	A-30
Thyristor Supply Section: Terminal Block Connection	A-30
Thyristor Supply Section: Busbar / Bus Duct Connection	A-31
Drive Sections: Terminal Block Connection	A-32
Drive Sections: Busbar Connection	A-32
NIOC Board Specifications	A-34
Application Programs	A-35
Protection Features	A-36
Applicable Standards	A-37
Materials	A-37
Transportation	A-37
Disposal	A-38
CE Marking	A-38
Compliance with the EMC Directive	A-38
Machinery Directive	A-40
CSA Marking	A-40
“C-tick” Marking	A-40
Compliance with AS/NZS 2064	A-40
Equipment Warranty and Liability	A-41
Limitation of Liability	A-42

Marine Applications – Technical Data

Ratings	B-1
Cabinet	B-1
Ambient Conditions	B-1

Applicable Standards B-2
Materials B-2
Other Technical Data B-2

Safety Instructions

Overview

This chapter states the safety instructions that must be followed when installing, operating and servicing the ACS 600 MultiDrive frequency converters. If neglected, physical injury and death may follow, or damage may occur to the frequency converter, the motor and driven equipment. The material in this chapter must be studied before attempting any work on, or with, the unit.

All personnel who will install or do maintenance shall be familiar with the safety instructions before opening the door of the ACS 600 MultiDrive frequency converter cabinet.

When installed and used in accordance with instructions, the ACS 600 MultiDrive causes no risk to its associated environment.

ACS 600 MultiDrive is referred to as ACx 600 in this chapter.

The following notation is used throughout the manual:



Dangerous Voltage WARNING! warns of situations in which a high voltage can cause physical injury and/or damage equipment. The text next to this symbol describes ways to avoid the danger.



General WARNING! warns of situations which can cause physical injury and/or damage equipment by means other than electrical. The text next to this symbol describes ways to avoid the danger.



Electrostatic Discharge WARNING! warns of situations in which an electrostatic discharge can damage equipment. The text next to this symbol describes ways to avoid the danger.

CAUTION! Aims to draw special attention to a particular issue.

Note: Gives additional information or points out more information available on the subject.

Operation

The doors of the ACS 600 MultiDrive frequency converter must be kept locked when the frequency converter is in operation.

The operator should be informed of the significance of the diagnostics. In case of an alarm indication, possibly followed by tripping, the operator should be able to decide whether part of the system should be removed from operation or whether the system should be restarted after resetting the alarm. In the event that part of the drive system is taken out of service, the appropriate maintenance personnel should be called to further investigate the problem.

In most cases, the diagnostic displays can be used for preliminary tracing of the fault location and fault resetting can be done without opening the door of the ACS 600 MultiDrive frequency converters.

Installation and Maintenance Safety

These safety instructions are intended for all work on the ACS 600 MultiDrive. Neglecting these instructions can cause physical injury or death.



WARNING! All electrical installation and maintenance work on the ACx 600 should be carried out by qualified electricians.

Any installation work must be done with power off, and power is not to be reconnected unless the installation work is complete. Dangerous residual voltages remain in capacitors when the disconnecting device is opened. Wait 5 minutes after switching off the supply before starting work. Always ensure by measuring that the voltage between terminals UDC+ and UDC- and frame is close to 0 V and that the supply has been switched off before performing any work on the equipment or making main circuit connections.

If the main circuit of the inverter unit is live, the motor terminals are also live even if the motor is not running!

Open switch fuses of all parallel connected inverters before installation or maintenance work in any of them.

Check the cable connections at the shipping split joints before switching on the supply voltage.

If the auxiliary voltage circuit of the ACx 600 is powered from an external power supply, opening the disconnecting device does not remove all voltages. Control voltages of 115/230 VAC may be present on the digital inputs or outputs even though the inverter unit is not powered. Before starting work, check which circuits remain live after opening of the disconnecting device by referring to the circuit diagrams for your particular delivery. Ensure by measuring that the part of the cabinet you are working on is not live.

In ACx 600 frequency converters, control boards of the converter unit may be at the main circuit potential. Dangerous voltages may be present between the control boards and the frame of the converter unit, when the main circuit voltage is on. It is critical that the measuring instruments, such as an oscilloscope, are used with caution and safety as a high priority. The fault tracing instructions give special mention of cases in which measurements may be performed on the control boards, also indicating the measuring method to be used.

Live parts on the inside of doors are protected against direct contact. Special safety attention shall be paid when handling shrouds made of sheet metal.

Do not make any voltage withstand tests on any part of the unit while the unit is connected. Disconnect motor cables before making any measurements on motors or motor cables.



WARNING! Close switch fuses of all parallel connected inverters before starting the frequency converter.

Do not open the drive section switch fuses when the inverter is running.

Do not use Prevention of Unexpected Start for stopping the drive when the inverter is running. Give a Stop command instead.

CAUTION! Fans may continue to rotate for a while after the disconnection of the electrical supply.

CAUTION! Some parts like heatsinks of power semiconductors and toroidal cores on motor cables inside of cabinet remain hot for a while after the disconnection of the electrical supply.

Starting TSU or DSU



Note the warning below before starting drives equipped with a Thyristor or Diode Supply Section.

WARNING! Before power switch-on, make sure that a sufficient inverter power is connected to the intermediate circuit. Rules of thumb:

1. The sum power of the inverters connected must be at least 30% of the sum power of all inverters.
2. The sum power of the inverters connected must be at least 30% of the rated power of the braking section ($P_{br.max}$) if present.

If the above mentioned rules are not followed, the DC fuses of the connected inverter(s) may blow or the braking chopper (if used) may be damaged.

The phenomena which result in a fuse blow are as follows:

- At start, a charging current high enough for charging all the inverters flows to the connected ones.
- In Thyristor Supply Sections, the DC voltage may overshoot the controller bridge change limit, causing an immediate change to regeneration and a high reverse current.
- The DC voltage may overshoot the braking chopper controller voltage limit, causing an immediate switching into braking mode and a high braking current, which in turn discharges low power inverter capacitors.

The braking chopper may be damaged by repeated on-off switching of the braking due to a high supply and braking section power compared to the inverter power.

ACA 635 (ISU) Supply



WARNING! ACA 635 must be supplied with a transformer dedicated to drives and motors or equipment of equal or higher power, or with a transformer equipped with two secondary windings, one of which is dedicated to drives and motors. Resonances might occur if there is capacitive load (e.g. lighting, PC, PLC, small power factor compensation capacitors) in the same network with ACA 635. The resonance current might damage some unit in the network.

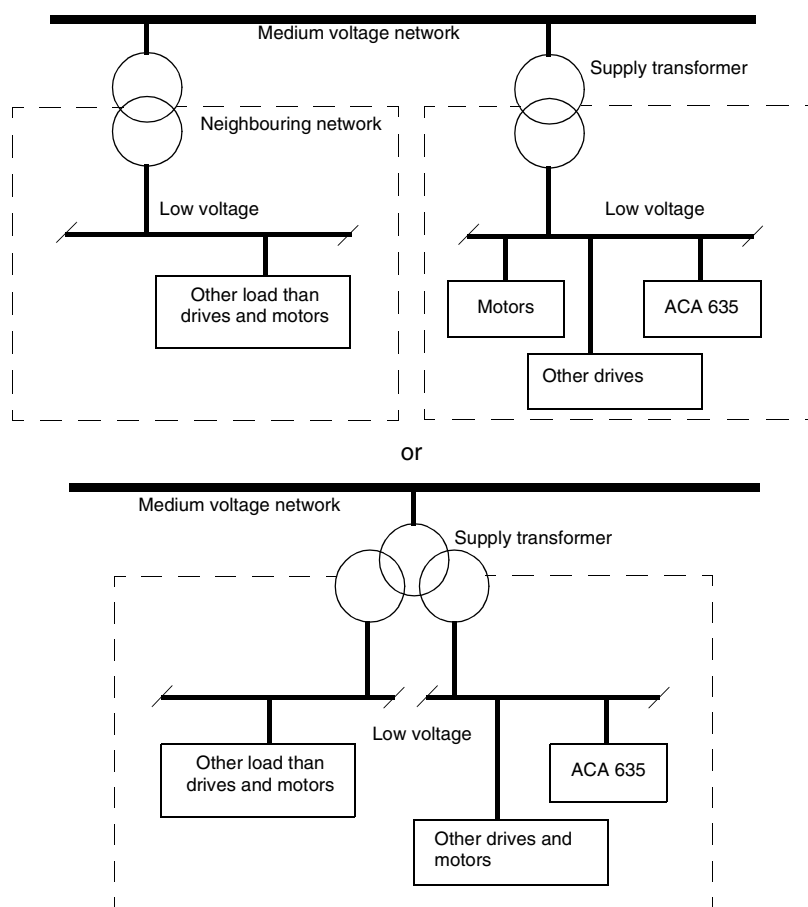

efesotomasyon.com

Supply Connections

The supply section is equipped with a disconnecting device. The electric parts of the whole drive system can be separated by the disconnecting device from the mains network for installation and maintenance work. The supply disconnecting device must be locked to the open position during installation and maintenance work. Both disconnecting devices of 12-pulse units must be locked to the open position during installation and maintenance work.

The supply section can be equipped with an earthing switch as an option. It is used to earth the AC busbars for safety reasons when work is being done on the system. The device is mechanically or electrically interlocked with the main switch.



WARNING! Each drive section can be equipped with an optional manually operated switch fuse for electrical disconnection. During maintenance work in the drive section or on the motor or the motor cable, the switch fuses of all parallel connected drive sections must be locked to the open position, or the DC fuses of all parallel connected drive sections must be removed if the switch fuses are not installed.

Opening the disconnecting device does not remove all control voltages. Before starting work, check with the circuit diagrams which circuits remain live after opening the disconnecting device. **Note:** Voltages from external control circuits may be present.

Earth Fault Protective Function

The ACx 600 is equipped with an internal earth fault protective function to protect the unit against earth faults in the inverter, the motor and the motor cable. This is not a personal safety or a fire protection feature. The internal earth fault protective function is not applicable in the parallel connected inverters. For more information on the earth fault parameter settings, see the appropriate firmware manual.

The supply of the ACx 600 can be equipped with an optional earth fault protective function, refer to *Supply Section Manuals*.

Emergency Stop Devices

Emergency stop devices must be installed at each operator control station and at other operating stations where emergency stop may be required. Pressing the  key on the Control Panel of ACS 600 MultiDrive does not generate an emergency stop of the motor or separate the drive from dangerous potential.

An emergency stop function has been provided (optional) in the ACx 600 to stop and switch off the whole drive. The available modes are: Immediate Removal of Power and Controlled Emergency Stop (with thyristor supply only). The emergency stop function must not be used as the normal mode of stopping the drive.

The emergency stop function complies to the principles of the standards listed below.

Table 1 Standards.

EN 292-1: 1991	Safety of machinery - Basic concepts, general principles for design - Part 1: Basic terminology, methodology
EN 292-2: 1991	Safety of machinery - Basic concepts, general principles for design - Part 2: technical principles and specifications
EN 418: 1992	Safety of machinery - Emergency stop equipment, functional aspects - Principles for design
EN 954-1: 1996	Safety of machinery - Safety related parts of control systems - Part 1: General principles for design
EN 60204-1: 1992 + Corr. 1993	Safety of machinery - electrical equipment of machines - Part 1: General principles for design

Immediate Removal of Power (Category 0)

After pressing the emergency stop push-button the power semiconductors of the inverter are blocked (coast stop) and the main contactor (or air circuit-breaker) is opened immediately. No attention is paid to deceleration of the speed of the motor shaft after the emergency stop is activated.

Controlled Emergency Stop (Category 1)

The installer has to make sure that the overriding control fulfils the requirements of EN 60204-1, category 1.

1. Upon receiving the emergency stop signal, each inverter starts braking (by ramp or torque limits) and acknowledges the signal by closing its output contact. (If the emergency stop signal is not acknowledged by all inverters within two seconds, the supply main contactor is opened.)
2. After a delay set with a time relay in the emergency stop circuitry, the supply main contactor is opened. The time delay should be set slightly longer than the inverter stop ramps to ensure controlled braking of all inverters.

Restart

In order to restart the drive system after an emergency stop, the emergency stop push-button has to be released and a reset given before the main contactor (or air circuit-breaker) can be closed and the drive started.

Prevention of Unexpected Start

For personnel safety, it must be possible for the operator to prevent unexpected start of the drive while the production machine is serviced. **Note:** Prevention of Unexpected Start must not to be used for stopping the drive when the inverter is running. A Stop command must be given instead.

The ACS 600 MultiDrive can be equipped with an optional Prevention of Unexpected Start according to the standards: EN 292-1: 1991, EN 292-2: 1991, EN 954-1: 1996, EN 60204-1-1: 1992 + Corr. 1993 (refer to Table 1) and EN 1037: 1995.

The function is achieved by disconnecting the control voltage to the power semiconductors of the inverter. Thus it is not possible for the power semiconductors to switch and generate the AC voltage needed to rotate the motor. In case of faulty main circuit components, the DC voltage from the busbar can be connected to the motor but an AC motor cannot rotate without the field generated by the AC voltage.

The operator activates the Prevention of Unexpected Start with a switch mounted on the control desk. When Prevention of Unexpected Start is activated, the switch is turned to position "0". A signal lamp will be lit on the control desk, indicating that Prevention of Unexpected Start is activated.



WARNING! Prevention of Unexpected Start does not disconnect the voltage of the main and auxiliary circuits. Therefore maintenance work on electrical parts can only be carried out after disconnecting the drive system.

Motor Connections



WARNING! Operation is not allowed if the motor nominal voltage is less than one half of the ACx 600 nominal input voltage, or the motor nominal current is less than 1/6 of the ACx 600 nominal output current (I_{2base} for 50s/60s duty cycle).

Pulses in the Drive Output

As with all frequency converters employing the most modern IGBT inverter technology, the ACS 600 output comprises – regardless of output frequency – pulses of approximately 1.35 times the mains network voltage with a very short rise time.

The voltage of the pulses can be almost double at the motor terminals, depending on the motor cable properties. This in turn can cause additional stress to the motor insulation.

Modern variable speed drives with their fast rising voltage pulses and high switching frequencies can cause current pulses through the bearings whose repeated discharging can gradually erode the bearing races.

Protecting the Motor Wiring

The stress to motor insulation can be avoided by optional ABB du/dt filters. du/dt filters also reduce bearing currents.

Protecting the Motor Bearing

To avoid damage occurring to motor bearings, insulated N (non-driven end) bearings must be used generally with 100 kW and higher motor powers. In addition, common mode filters from ABB must be used according to the following table. The common mode filter is composed of toroidal cores installed onto the motor cable. The cables must be selected and installed according to the instructions given in the appropriate *Hardware Manual*. The precautions to minimize the risk on motor bearing damage depend on the motor size and rated power. Three types of filters are used alone or in combinations:

1. optional ACS 600 du/dt filter (protects motor insulation system and reduces bearing currents)
2. ACS 600 common mode filter (mainly reduces bearing currents)
3. ACS 600 light common mode filter (mainly reduces bearing currents).

Requirements Table

The following table shows how to select the motor insulation system and when optional ACS 600 du/dt filters, insulated N (non-driven end) motor bearings and ACS 600 common mode filters are required at the output of the drive. The motor manufacturer should be consulted regarding the construction of the motor insulation and additional requirements for explosion-safe motors. Failure of the motor to fulfil the following requirements may shorten its life or damage the motor bearings.

Manufacturer	Motor Type	Nominal Mains Voltage	Requirement for			
			Motor Insulation System	ACS 600 du/dt Filter, ACS 600 Common Mode Filter and Insulated N-bearing		
				$P_N < 100 \text{ kW}$ and Frame Size < IEC 315	$100 \text{ kW} \leq P_N < 350 \text{ kW}$ or Frame Size \geq IEC 315	$P_N \geq 350 \text{ kW}$
A B B	Random-wound M2_ and M3_	$U_N \leq 500 \text{ V}$	Standard	-	+ N	+ N + CMF
		$500 \text{ V} < U_N \leq 600 \text{ V}$	Standard	+ du/dt	+ du/dt	+ du/dt + N + LCMF
			or	Reinforced	-	+ N
	$600 \text{ V} < U_N \leq 690 \text{ V}$	Reinforced	+ du/dt	+ du/dt	+ du/dt + N + LCMF	
	Form-wound HXR and AM_	$380 \text{ V} < U_N \leq 690 \text{ V}$	Standard	n.a.	+ N + CMF	+ N + CMF
	Old* form-wound HX_ and modular	$380 \text{ V} < U_N \leq 690 \text{ V}$	Check from the motor manufacturer.	+ du/dt filter with voltages over 500 V + N + CMF		
Random-wound HXR	$380 \text{ V} < U_N \leq 690 \text{ V}$	Check from the motor manufacturer.	+ du/dt filter with voltages over 500 V + N + CMF			
N O N - A B B	Random-wound	$U_N \leq 420 \text{ V}$	Standard: $\dot{U}_{LL} = 1300 \text{ V}$	-	+ N or CMF	+ N + CMF
		$420 \text{ V} < U_N \leq 500 \text{ V}$	Standard: $\dot{U}_{LL} = 1300 \text{ V}$	+ du/dt	+ du/dt + N	+ du/dt + N + CMF
				or	+ du/dt + CMF	
		or	Reinforced: $\dot{U}_{LL} = 1600 \text{ V}$, 0.2 microsecond rise time	-	+ N or CMF	+ N + CMF
	$500 \text{ V} < U_N \leq 600 \text{ V}$	Reinforced: $\dot{U}_{LL} = 1600 \text{ V}$	+ du/dt	+ du/dt	+ du/dt + N + LCMF	
		or	Reinforced: $\dot{U}_{LL} = 1800 \text{ V}$	-	+ N or CMF	+ N + CMF
		$600 \text{ V} < U_N \leq 690 \text{ V}$	Reinforced: $\dot{U}_{LL} = 1800 \text{ V}$	+ du/dt	+ du/dt	+ du/dt + N + LCMF
Form-wound	$U_N \leq 690 \text{ V}$	Reinforced: $\dot{U}_{LL} = 2000 \text{ V}$, 0.3 microsecond rise time	n.a.	+ N + CMF	+ N + CMF	

* manufactured before 1992

Note 1: The abbreviations and concepts used in the table are defined below.

Abbreviation	Concept	Definition
-	U_N	nominal mains voltage
-	$\hat{U}_{LL} = \dots V$	peak line to line voltage at motor terminals which the motor insulation withstands
-	Rise time: $\Delta t = 0.8 \cdot \hat{U}_{LL} / (du/dt)$	The time interval during which the line to line voltage at motor terminals changes from 10 % to 90 % of the whole voltage range. \hat{U}_{LL} and Δt depend on cable length. See the figures below.
-	P_N	motor nominal power
du/dt	-	du/dt filter
CMF	Common mode filter	3 toroidal cores per each motor cable
LCMF	Light common mode filter	1 toroidal core per each motor cable
N	N-bearing	insulated motor non-driven end bearing
n.a.	-	Motors of this power range are not available as standard units. Consult the motor manufacturer.

Note 2: *ACA 635 IGBT Supply Sections and the ACS/ACC 611*

If voltage is raised by the ACA 635 or the ACS/ACC 611, select the motor insulation system according to the increased intermediate circuit d.c. voltage level, especially in the 500 V (+10%) supply voltage range.

Note 3: *HXR and AMA Motors*

All AMA machines (manufactured in Helsinki) to be supplied by a frequency converter have form-wound windings. All HXR machines manufactured in Helsinki since 1997 have form-wound windings.

Note 4: *Chopper Resistor Braking*

When the drive is in braking mode for a large part of its operation time, the intermediate circuit DC voltage of the drive increases, the effect being similar to increasing the supply voltage by up to 20 percent. This should be taken into consideration when determining the motor insulation requirement.

Example: Motor insulation requirement for a 400 V application must be selected as if the drive was supplied with 480 V.

Note 5: This table applies to NEMA motors with the following heading.

$P_N < 134 \text{ HP}$ and Frame Size < NEMA 500	$134 \text{ HP} \leq P_N < 469 \text{ HP}$ or Frame Size \geq NEMA 500	$P_N \geq 469 \text{ HP}$
---	---	---------------------------

Without Filtering Below is a diagram of \hat{U}_{LL} and du/dt as a function of cable length when no du/dt filter is used.

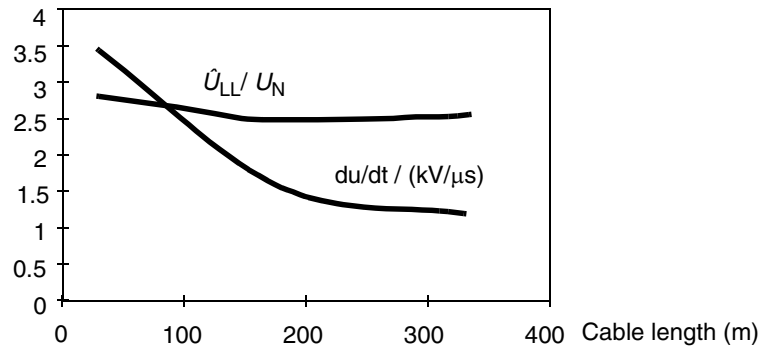

With du/dt Filter Below is a diagram of \hat{U}_{LL} and du/dt as a function of cable length with du/dt filter at the output of the ACx 600.

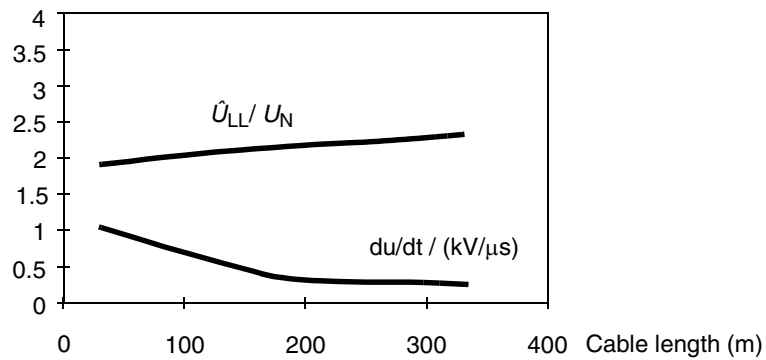

Power Factor Compensation Capacitors Power factor compensation capacitors and surge absorbers must not be connected to the motor cables. These devices are not designed to be used with frequency converters, and will degrade motor control accuracy. They can cause permanent damage to the ACx 600 or themselves due to the rapid changes in the ACx 600 output voltage.

If there are power factor compensation capacitors in parallel with the ACx 600 make sure that the capacitors and the ACx 600 are not charged simultaneously to avoid voltage surges which might damage the unit.

Components Connected to Digital/Analogue Inputs



WARNING! IEC 664 requires double or reinforced insulation between live parts and the surface of accessible parts of electrical equipment which are either non-conductive or conductive but not connected to the protective earth.

To fulfil this requirement, the connection of a thermistor (and other similar components) to the digital inputs of ACx 600 can be implemented in three alternate ways:

1. There is double or reinforced insulation between the thermistor and live parts of the motor.
 2. Circuits connected to all digital and analogue inputs of the ACx 600
 - are protected against contact, and
 - insulated with basic insulation (the same voltage level as the converter main circuit) from other low voltage circuits.
 3. An external thermistor relay is used. The insulation of the relay must be rated for the same voltage level as the converter main circuit.
-

EMC

Note: If safety switches, contactors, connection boxes or similar equipment are used in the motor cable, they should be installed in a metal enclosure with 360 degrees earthing for the screens of both the incoming cable and the outgoing cable, or the screens of the cables should otherwise be connected together.





WARNING! The printed circuit boards contain integrated circuits that are extremely sensitive to electrostatic discharge. Exercise appropriate care when working on the unit to avoid permanent damage to the circuits. Do not touch the boards unnecessarily. When handling the printed circuit boards, the use of a properly earthed wrist strap and other appropriate material for the handling of printed circuit boards is recommended.

Fibre Optic Cables

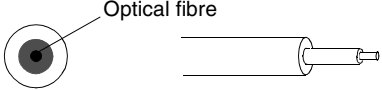
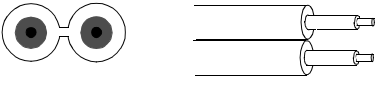

WARNING! Handle the fibre optic cables with care (especially when joining the shipping splits). When unplugging optic cables, always grab the connector, not the cable itself. Do not touch the ends of the fibres with bare hands as the fibre is extremely sensitive to dirt.

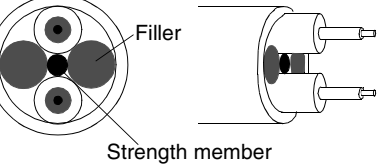
Cable Type	Parameter	Minimum	Maximum	Unit
Plastic Optical Cable (POF, fibre core diameter 1 mm): Simplex  Duplex (zipcord) 	Storage and Operating Temperature	-55	+85	°C
	Recommended Operating Temperature	-40	+85	°C
	Installation Temperature	-20	+70	°C
	Short Term Tensile Force		Simplex: 50 Duplex: 100	N
	Short Term Bend Radius	25		mm
	Long Term Bend Radius	35		mm
	Long Term Tensile Load		1	N
	Flexing		1000	cycles
Hard Clad Silica Oval Shape Duplex Cable (HCS[®], SpecTran, fibre core diameter 200 µm, outer dimensions 3.2 x 5.4 mm) 	Storage Temperature	-40	+80	°C
	Operating Temperature	-20	+80	°C
	Short Term Tensile Force		46/205	lbs./N
	Long Term Tensile Force		10/44	lbs./N
	Bend Radius	25		mm
Hard Clad Silica 2-channel (Duplex) Cable (HCS[®], SpecTran, fibre core diameter 200 µm, outer diameter 7.5 mm): 	Storage and Operating Temperature	-40	+85	°C
	Short Term Tensile Force		46/205	lbs./N
	Long Term Tensile Force		10/44	lbs./N
	Bend Radius	75		mm

Cooling



WARNING! The cooling air flow and space requirements must be fulfilled. Air flow from below (from a cable conduit) to the cabinet must be prevented to ensure the degree of protection and fire protection.

Mechanical Installation **CAUTION!** Fastening any device to the cabinet frame for lifting purposes is forbidden.

CAUTION! Make sure that dust from drilling does not enter the cabinet when installing. Electrically conductive dust inside the unit may cause damage or lead to malfunction.

CAUTION! Welding of the cabinet frame is not recommended because it may damage electronic circuits located in the drive sections. However, if electric welding is the only way to mount the cabinet connect the return conductor of the welding equipment low to the cabinet frame within 0.5 metres of the welding point to reduce the risk of damage.

ACS 600 MultiDrive – Technical Data

Abbreviations

The abbreviations used in the following supply and drive section rating tables are explained below.

Supply Section	Drive Section
I_{1N} Total rms input current (continuous a.c. current)	I_{2N} Rated rms a.c. output current (= maximum continuous output current)
<p>Duty Cycle (10 s / 60 s)</p> I_{DCbase} Maximum base current with I_{DCmax} . I_{DCbase} is 60 % of I_{DC} . I_{DCmax} Short term rms overload d.c. current (allowed for 10 seconds every 60 seconds)	<p>200 % Duty Cycle (10 s / 60 s)</p> I_{2base} Maximum base current with I_{2max} . I_{2base} is the nominal heavy duty output current. I_{2max} Short term rms a.c. overload current (allowed for 10 seconds every 60 seconds) i.e. maximum output current
<p>Duty Cycle (1 min / 5 min)</p> I_{DCbase} Maximum base current with I_{DCmax} . I_{DCbase} is 60 % of I_{DC} . I_{DCmax} Short term rms overload d.c. current (allowed for one minute every 5 minutes).	<p>150 % Duty Cycle (1 min / 5 min)</p> I_{2base} Maximum base current with I_{2max} I_{2max} Short term rms a.c. overload current (allowed for one minute every 5 minutes)
I_{DC} Continuous d.c. current S_N Rated apparent output power of the supply section P_N Nominal output power (continuous active power) P_G Regenerative braking power to mains P_{loss} Power loss U_N Nominal mains voltage	S_N Rated apparent output power of the drive section P_N Typical motor power. The power ratings in kW apply to most IEC 34 motors. U_N Nominal mains voltage

Note 1: Drive section output currents are valid when output frequency is above 10 Hz.

Note 2: The ratings given correspond to voltage U_N and fan supply voltage 230 V or 115 V.

Note 3: The limiting factor for P_G in thyristor supply sections with autotransformer is either the autotransformer or the generator bridge current depending on the configuration of the supply section.

Supply Section Tables The following tables specify the ratings for the supply sections. For IGBT supply section ratings see *ACA 635 IGBT Supply Sections User's Manual* (EN code 64013700).

Notes The notes concerning the supply section tables are listed below.

P_{loss} P_{loss} is the heat loss of a unit with basic options.

Noise Level Noise level applies to echoless room.

Height Cabinet height is 2072 mm for IP 54R classification.

Weight/Width Bottom and top entry weights in the following tables apply to units with basic options and aluminium DC busbars. **Width (EMC)** is the width of the EMC filter cabinet, **Weight (EMC)** is the additional weight due to the EMC filter cabinet.

An auxiliary control unit is included in every ACS 600 MultiDrive delivery. The following tables do not include the width and weight of the auxiliary control unit: 400 mm (approximately 170 kg) or 600 mm (approximately 190 kg).

Ratings 380...415 V The table below shows the nominal ratings for the 400 V range supply sections.

Type Marking	Nominal Ratings					Duty Cycle (10 s / 60 s)		Duty Cycle (1 min / 5 min)		Frame	Air Flow m ³ /h	P _{loss} kW	Noise Level dBA
	S _N kVA	I _{1N} A	I _{DC} A	P _N kW	P _G kW	I _{DCbase} A	I _{DCmax} A	I _{DCbase} A	I _{DCmax} A				
Diode supply sections (380...415 V Range, U_N = 400 V)													
ACA 631-0140-31-xx	140	202	247	131	–	148	317	148	289	B2	370	1.5	56
ACA 631-0200-31-xx	200	289	354	188	–	212	455	212	414	B2	370	2.3	56
ACA 631-0300-31-xx	300	433	530	282	–	318	795	318	700	B3	770	2.8	64
ACA 631-0420-31-xx	420	606	742	394	–	445	1113	445	979	B3	770	3.6	64
ACA 631-0680-31-xx	680	981	1202	639	–	721	1947	721	1406	B4	1500	6.3	70
ACA 631-1120-31-xx	1120	1617	1980	1053	–	1188	3208	1188	2317	B4	1500	10.2	70
ACA 631-1700-31-xx	1697	2449	3000	1595	–	1800	4860	1800	3798	B5	2800	16.5	74
ACA 631-2100-31-xx	1980	2858	3500	1861	–	2100	5670	2100	4431	B5	2800	20.8	74
Thyristor supply sections (380...415 V Range, U_N = 400 V)													
ACA 632-0015-31-xx	12	18	22	12	11	13	28	13	26	B1	150	1.1	55
ACA 632-0030-31-xx	26	37	45	24	22	27	58	27	53	B1	150	1.1	55
ACA 632-0040-31-xx	38	55	67	36	32	40	86	40	78	B1	150	1.1	55
ACA 632-0070-31-xx	71	102	125	66	60	75	161	75	146	B1	150	1.1	55
ACA 632-0140-31-xx	140	202	247	131	118	148	317	148	289	B2	370	1.5	56
ACA 632-0200-31-xx	200	289	354	188	169	212	455	212	414	B2	370	2.3	56
ACA 632-0300-31-xx	300	433	530	282	254	318	795	318	700	B3	770	2.8	64
ACA 632-0420-31-xx	420	606	742	394	355	445	1113	445	979	B3	770	3.6	64
ACA 632-0680-31-xx	680	981	1202	639	575	721	1947	721	1406	B4	2500	6.3	72
ACA 632-1120-31-xx	1120	1617	1980	1053	947	1188	3208	1188	2317	B4	2500	10.2	72
ACA 632-1700-31-xx	1697	2449	3000	1595	1435	1800	4860	1800	3798	B5	4500	16.5	75
ACA 632-2100-31-xx	1980	2858	3500	1861	1675	2100	5670	2100	4431	B5	4500	20.8	75
Asymmetrical thyristor supply sections (380...415 V Range, U_N = 400 V)													
ACA 632-1700/0680-31-xx	1697	2449	3000	1595	575	1800	4860	1800	3798	B5	4500	16.5	75
ACA 632-1700/1120-31-xx	1697	2449	3000	1595	947	1800	4860	1800	3798	B5	4500	16.5	75
ACA 632-2100/0680-31-xx	1980	2858	3500	1861	575	2100	5670	2100	4431	B5	4500	20.8	75
ACA 632-2100/1120-31-xx	1980	2858	3500	1861	947	2100	5670	2100	4431	B5	4500	20.8	75
12 pulse diode supply sections (380...415 V Range, U_N = 400 V)													
ACA 633-0280-31-xx	280	404	494	263	–	296	634	296	578	B2	2x370	2x1.5	56
ACA 633-0400-31-xx	400	578	708	376	–	425	909	425	828	B2	2x370	2x2.3	56
ACA 633-0600-31-xx	600	866	1060	564	–	636	1590	636	1399	B3	2x770	2x2.8	64
ACA 633-0840-31-xx	840	1212	1484	789	–	890	2226	890	1959	B3	2x770	2x3.6	64
ACA 633-1360-31-xx	1360	1962	2404	1279	–	1442	3894	1442	2813	B4	2x1500	2x6.3	72
ACA 633-2240-31-xx	2240	3234	3960	2106	–	2376	6415	2376	4633	B4	2x1500	2x10.2	72
ACA 633-3400-31-xx	3394	4898	6000	3190	–	3600	9720	3600	7596	B5	2x2800	2x16.5	75
6 pulse thyristor supply sections with autotransformer (380...415 V Range, U_N = 400 V)													
ACA 634-0200-31-xx	200	289	354	188	171	212	455	212	414	B2	370	2.3	56
ACA 634-0420-31-xx	420	606	742	394	388	445	1113	445	979	B3	770	3.6	64
ACA 634-0680-31-xx	680	981	1202	639	639	721	1947	721	1406	B4	2500	6.3	72
ACA 634-1120-31-xx	1120	1617	1980	1053	639	1188	3208	1188	2317	B4	2500	10.2	72
ACA 634-1700-31-xx	1697	2449	3000	1595	1065	1800	4860	1800	3798	B5	4500	16.5	75
ACA 634-2100-31-xx	1980	2858	3500	1861	1065	2100	5670	2100	4431	B5	4500	20.8	75
12 pulse thyristor supply sections (380...415 V Range, U_N = 400 V)													
ACA 636-0800-31-xx	798	1151	1410	761	685	846	2115	846	1861	B3	2x770	2x3.6	66
ACA 636-1290-31-xx	1292	1865	2284	1232	1109	1370	3700	1370	2672	B4	2x2500	2x6.3	74
ACA 636-2130-31-xx	2128	3072	3763	2030	1827	2257	6094	2257	4402	B4	2x2500	2x10.2	74
ACA 636-3220-31-xx	3224	4654	5701	3076	2768	3420	9234	3420	7216	B5	2x4500	2x16.5	77
12 pulse thyristor supply sections with autotransformer (380...415 V Range, U_N = 400 V)													
ACA 638-0800-31-xx	798	1151	1410	761	761	846	2115	846	1861	B3	2x770	2x3.6	66
ACA 638-1290-31-xx	1292	1865	2284	1232	776	1370	3700	1370	2672	B4	2x2500	2x6.3	74
ACA 638-2130-31-xx	2128	3072	3763	2030	1277	2257	6094	2257	4402	B4	2x2500	2x10.2	74
ACA 638-3220-31-xx	3224	4654	5701	3076	2130	3420	9234	3420	7216	B5	2x4500	2x16.5	77
12/6 pulse thyristor supply sections with autotransformer (380...415 V Range, U_N = 400 V)													
ACA 639-0800-31-xx	798	1151	1410	761	380	846	2115	846	1861	B3	2x770	2x3.6	66
ACA 639-1290-31-xx	1292	1865	2284	1232	388	1370	3700	1370	2672	B4	4000	2x6.3	74
ACA 639-2130-31-xx	2128	3072	3763	2030	639	2257	6094	2257	4402	B4	4000	2x10.2	74
ACA 639-3220-31-xx	3224	4654	5701	3076	1065	3420	9234	3420	7216	B5	7300	2x16.5	77

PDM code 00001749-C

Ratings 380...500 V The table below shows the nominal ratings for the 500 V range supply sections.

Type Marking	Nominal Ratings					Duty Cycle (10 s / 60 s)		Duty Cycle (1 min / 5 min)		Frame	Air Flow m ³ /h	P _{loss} kW	Noise Level dBA
	S _N	I _{1N}	I _{DC}	P _N	P _G	I _{DCbase}	I _{DCmax}	I _{DCbase}	I _{DCmax}				
	kVA	A	A	kW	kW	A	A	A	A				
Diode supply sections (380...500 V Range, U_N = 500 V)													
ACA 631-0175-51-xx	175	202	247	163	–	148	317	148	289	B2	370	1.5	56
ACA 631-0250-51-xx	250	289	354	233	–	212	455	212	414	B2	370	2.3	56
ACA 631-0375-51-xx	375	433	530	349	–	318	795	318	700	B3	770	2.8	64
ACA 631-0525-51-xx	525	606	742	489	–	445	1113	445	979	B3	770	3.6	64
ACA 631-0850-51-xx	850	981	1202	792	–	721	1947	721	1406	B4	1500	6.3	70
ACA 631-1400-51-xx	1400	1617	1980	1304	–	1188	3208	1188	2317	B4	1500	10.2	70
ACA 631-2120-51-xx	2120	2449	3000	1976	–	1800	4860	1800	3798	B5	2800	16.5	74
ACA 631-2600-51-xx	2475	2858	3500	2305	–	2100	5670	2100	4431	B5	2800	20.8	74
Thyristor supply sections (380...500 V Range, U_N = 500 V)													
ACA 632-0020-51-xx	16	18	22	15	13	13	28	13	26	B1	150	1.1	55
ACA 632-0035-51-xx	32	37	45	30	27	27	58	27	53	B1	150	1.1	55
ACA 632-0050-51-xx	47	55	67	44	40	40	86	40	78	B1	150	1.1	55
ACA 632-0090-51-xx	88	102	125	82	74	75	161	75	146	B1	150	1.1	55
ACA 632-0175-51-xx	175	202	247	163	147	148	317	148	289	B2	370	1.5	56
ACA 632-0250-51-xx	250	289	354	233	210	212	455	212	414	B2	370	2.3	56
ACA 632-0375-51-xx	375	433	530	349	314	318	795	318	700	B3	770	2.8	64
ACA 632-0525-51-xx	525	606	742	489	440	445	1113	445	979	B3	770	3.6	64
ACA 632-0850-51-xx	850	981	1202	792	713	721	1947	721	1406	B4	2500	6.3	72
ACA 632-1400-51-xx	1400	1617	1980	1304	1174	1188	3208	1188	2317	B4	2500	10.2	72
ACA 632-2120-51-xx	2120	2449	3000	1976	1778	1800	4860	1800	3798	B5	4500	16.5	75
ACA 632-2600-51-xx	2475	2858	3500	2305	2074	2100	5670	2100	4431	B5	4500	20.8	75
Asymmetrical thyristor supply sections (380...500 V Range, U_N = 500 V)													
ACA 632-2120/0850-51-xx	2120	2449	3000	1976	713	1800	4860	1800	3798	B5	4500	16.5	75
ACA 632-2120/1400-51-xx	2120	2449	3000	1976	1174	1800	4860	1800	3798	B5	4500	16.5	75
ACA 632-2600/0850-51-xx	2475	2858	3500	2305	713	2100	5670	2100	4431	B5	4500	20.8	75
ACA 632-2600/1400-51-xx	2475	2858	3500	2305	1174	2100	5670	2100	4431	B5	4500	20.8	75
12 pulse diode supply sections (380...500 V Range, U_N = 500 V)													
ACA 633-0350-51-xx	350	404	494	326	–	296	634	296	578	B2	2x370	2x1.5	56
ACA 633-0500-51-xx	500	578	708	466	–	425	909	425	828	B2	2x370	2x2.3	56
ACA 633-0750-51-xx	750	866	1060	698	–	636	1590	636	1399	B3	2x770	2x2.8	64
ACA 633-1050-51-xx	1050	1212	1484	978	–	890	2226	890	1959	B3	2x770	2x3.6	64
ACA 633-1700-51-xx	1700	1962	2404	1584	–	1442	3894	1442	2813	B4	2x1500	2x6.3	72
ACA 633-2800-51-xx	2800	3234	3960	2608	–	2376	6415	2376	4633	B4	2x1500	2x10.2	72
ACA 633-4240-51-xx	4240	4898	6000	3952	–	3600	9720	3600	7596	B5	2x2800	2x16.5	75
6 pulse thyristor supply sections with autotransformer (380...500 V Range, U_N = 500 V)													
ACA 634-0250-51-xx	250	289	354	233	190	212	455	212	414	B2	370	2.3	56
ACA 634-0375-51-xx	375	433	530	349	380	318	795	318	700	B3	770	2.8	64
ACA 634-0850-51-xx	850	981	1202	792	645	721	1947	721	1406	B4	2500	6.3	72
ACA 634-1400-51-xx	1400	1617	1980	1304	1063	1188	3208	1188	2317	B4	2500	10.2	72
ACA 634-2120-51-xx	2120	2449	3000	1976	1063	1800	4860	1800	3798	B5	4500	16.5	75
ACA 634-2600-51-xx	2475	2858	3500	2305	1874	2100	5670	2100	4431	B5	4500	20.8	75
12 pulse thyristor supply sections (380...500 V Range, U_N = 500 V)													
ACA 636-1000-51-xx	997	1151	1410	929	836	846	2115	846	1861	B3	2x770	2x3.6	66
ACA 636-1615-51-xx	1614	1864	2283	1504	1353	1370	3700	1370	2672	B4	2x2500	2x6.3	74
ACA 636-2660-51-xx	2661	3072	3764	2479	2231	2257	6094	2257	4402	B4	2x2500	2x10.2	74
ACA 636-4030-51-xx	4030	4653	5700	3754	3378	3420	9234	3420	7216	B5	2x4500	2x16.5	77
ACA 636-4700-51-xx	4703	5430	6652	4381	3943	3990	10773	3990	8419	B5	2x4500	2x20.8	77
12 pulse thyristor supply sections with autotransformer (380...500 V Range, U_N = 500 V)													
ACA 638-1000-51-xx	997	1151	1410	929	722	846	2115	846	1861	B3	2x770	2x3.6	66
ACA 638-1615-51-xx	1614	1864	2283	1504	1170	1370	3700	1370	2672	B4	2x2500	2x6.3	74
ACA 638-2660-51-xx	2661	3072	3764	2479	1927	2257	6094	2257	4402	B4	2x2500	2x10.2	74
ACA 638-4030-51-xx	4030	4653	5700	3754	3580	3420	9234	3420	7216	B5	2x4500	2x16.5	77
ACA 638-4700-51-xx	4703	5430	6652	4381	3580	3990	10773	3990	8419	B5	2x4500	2x20.8	77
12/6 pulse thyristor supply sections with autotransformer (380...500 V Range, U_N = 500 V)													
ACA 639-1000-51-xx	997	1151	1410	929	361	846	2115	846	1861	B3	2x770	2x3.6	66
ACA 639-1615-51-xx	1614	1864	2283	1504	585	1370	3700	1370	2672	B4	4000	2x6.3	74
ACA 639-2660-51-xx	2661	3072	3764	2479	963	2257	6094	2257	4402	B4	4000	2x10.2	74
ACA 639-4030-51-xx	4030	4653	5700	3754	1790	3420	9234	3420	7216	B5	7300	2x16.5	77
ACA 639-4700-51-xx	4703	5430	6652	4381	1790	3990	10773	3990	8419	B5	7300	2x20.8	77

PDM code 00001749-C

Ratings 525...690 V The table below shows the nominal ratings for the 690 V range supply sections.

Type Marking	Nominal Ratings					Duty Cycle (10 s / 60 s)		Duty Cycle (1 min / 5 min)		Frame	Air Flow m ³ /h	P _{loss} kW	Noise Level dBA
	S _N	I _N	I _{DC}	P _N	P _G	I _{DCbase}	I _{DCmax}	I _{DCbase}	I _{DCmax}				
	kVA	A	A	kW	kW	A	A	A	A				
Diode supply sections (525...690 V Range, U_N = 690 V)													
ACA 631-0090-61-xx	90	75	92	83	–	55	118	55	108	B2	370	0.6	56
ACA 631-0175-61-xx	175	146	179	161	–	107	230	107	209	B2	370	1.5	56
ACA 631-0250-61-xx	250	209	256	231	–	154	329	154	300	B2	370	2.3	56
ACA 631-0375-61-xx	375	314	384	346	–	230	576	230	507	B3	770	2.8	64
ACA 631-0525-61-xx	525	439	538	484	–	323	807	323	710	B3	770	3.6	64
ACA 631-0850-61-xx	850	711	871	784	–	523	1411	523	1019	B4	1500	6.3	70
ACA 631-1400-61-xx	1400	1171	1435	1292	–	861	2325	861	1679	B4	1500	10.2	70
ACA 631-2600-61-xx	2600	2176	2664	2400	–	1598	4316	1598	3373	B5	2800	16.5	74
ACA 631-3600-61-xx	3415	2858	3500	3152	–	2100	5670	2100	4431	B5	2800	20.8	74
Thyristor supply sections (525...690 V Range, U_N = 690 V)													
ACA 632-0090-61-xx	90	75	92	83	74	55	118	55	108	B2	370	0.6	56
ACA 632-0175-61-xx	175	146	179	161	145	107	230	107	209	B2	370	1.5	56
ACA 632-0250-61-xx	250	209	256	231	207	154	329	154	300	B2	370	2.3	56
ACA 632-0375-61-xx	375	314	384	346	312	230	576	230	507	B3	770	2.8	64
ACA 632-0525-61-xx	525	439	538	484	436	323	807	323	710	B3	770	3.6	64
ACA 632-0850-61-xx	850	711	871	784	706	523	1411	523	1019	B4	2500	6.3	72
ACA 632-1400-61-xx	1400	1171	1435	1292	1163	861	2325	861	1679	B4	2500	10.2	72
ACA 632-2600-61-xx	2600	2176	2664	2399	2159	1598	4316	1598	3373	B5	4500	16.5	75
ACA 632-3600-61-xx	3415	2858	3500	3152	2837	2100	5670	2100	4431	B5	4500	20.8	75
Asymmetrical thyristor supply sections (525...690 V Range, U_N = 690 V)													
ACA 632-2600/0850-61-xx	2600	2176	2664	2399	706	1598	4316	1598	3373	B5	4500	16.5	75
ACA 632-2600/1400-61-xx	2600	2176	2664	2399	1163	1598	4316	1598	3373	B5	4500	16.5	75
ACA 632-3600/0850-61-xx	3415	2858	3500	3152	706	2100	5670	2100	4431	B5	4500	20.8	75
ACA 632-3600/1400-61-xx	3415	2858	3500	3152	1163	2100	5670	2100	4431	B5	4500	20.8	75
ACA 632-3600/2600-61-xx	3415	2858	3500	3152	2159	2100	5670	2100	4431	B5	4500	20.8	75
12 pulse diode supply sections (525...690 V Range, U_N = 690 V)													
ACA 633-0180-61-xx	180	150	184	165	–	110	236	110	215	B2	2x370	2x0.6	56
ACA 633-0350-61-xx	350	292	358	322	–	215	460	215	419	B2	2x370	2x1.5	56
ACA 633-0500-61-xx	500	418	512	461	–	307	657	307	599	B2	2x370	2x2.3	56
ACA 633-0750-61-xx	750	628	768	693	–	461	1152	461	1014	B3	2x770	2x2.8	64
ACA 633-1050-61-xx	1050	878	1076	968	–	646	1614	646	1420	B3	2x770	2x3.6	64
ACA 633-1700-61-xx	1700	1422	1742	1569	–	1045	2822	1045	2038	B4	2x1500	2x6.3	72
ACA 633-2800-61-xx	2800	2342	2870	2583	–	1722	4649	1722	3358	B4	2x1500	2x10.2	72
ACA 633-5200-61-xx	5200	4352	5328	4798	–	3197	8631	3197	6745	B5	2x2800	2x16.5	75
6 pulse thyristor supply sections with autotransformer (525...690 V Range, U_N = 690 V)													
ACA 634-1400-61-xx	1400	1171	1435	1292	1063	861	2325	861	1679	B4	2500	10.2	72
ACA 634-2600-61-xx	2600	2176	2664	2399	1874	1598	4316	1598	3373	B5	4500	16.5	75
ACA 634-3600-61-xx	3415	2858	3500	3152	1874	2100	5670	2100	4431	B5	4500	20.8	75
12 pulse thyristor supply sections (525...690 V Range, U_N = 690 V)													
ACA 636-1000-61-xx	997	834	1022	920	828	613	1533	613	1349	B3	2x770	2x3.6	66
ACA 636-1615-61-xx	1614	1351	1655	1490	1341	993	2681	993	1936	B4	2x2500	2x6.3	74
ACA 636-2660-61-xx	2659	2225	2726	2455	2209	1636	4417	1636	3190	B4	2x2500	2x10.2	74
ACA 636-4950-61-xx	4941	4134	5065	4561	4105	3037	8200	3037	6408	B5	2x4500	2x16.5	77
ACA 636-6500-61-xx	6490	5430	6652	5991	5392	3990	10773	3990	8419	B5	2x4500	2x20.8	77
12 pulse thyristor supply sections with autotransformer (525...690 V Range, U_N = 690 V)													
ACA 638-1615-61-xx	1614	1351	1655	1490	1344	993	2681	993	1936	B4	2x2500	2x6.3	74
ACA 638-2660-61-xx	2659	2225	2726	2455	2214	1636	4417	1636	3190	B4	2x2500	2x10.2	74
ACA 638-4950-61-xx	4941	4134	5065	4561	3905	3037	8200	3037	6408	B5	2x4500	2x16.5	77
ACA 638-6500-61-xx	6490	5430	6652	5991	3905	3990	10773	3990	8419	B5	2x4500	2x20.8	77
12/6 pulse thyristor supply sections with autotransformer (525...690 V Range, U_N = 690 V)													
ACA 639-1615-61-xx	1614	1351	1655	1490	672	993	2681	993	1936	B4	4000	2x6.3	74
ACA 639-2660-61-xx	2659	2225	2726	2455	1107	1636	4417	1636	3190	B4	4000	2x10.2	74
ACA 639-4950-61-xx	4941	4134	5065	4561	1952	3037	8200	3037	6408	B5	7300	2x16.5	77
ACA 639-6500-61-xx	6490	5430	6652	5991	1952	3990	10773	3990	8419	B5	7300	2x20.8	77

PDM code 00001749-C

Ratings 830 V The table below shows the nominal ratings for the 830 V supply sections.

Type Marking	Nominal Ratings					Duty Cycle (10 s / 60 s)		Duty Cycle (1 min / 5 min)		Frame	Air Flow m ³ /h	P _{loss} kW	Noise Level dBA
	S _N kVA	I _N A	I _{DC} A	P _N kW	P _G kW	I _{DCbase} A	I _{DCmax} A	I _{DCbase} A	I _{DCmax} A				
Thyristor supply sections (525...830 V Range, U _N = 830 V)													
ACA 632-1680-81-xx	1680	1169	1432	1290	1290	859	2320	859	1675	B4	2500	6.3	72
ACA 632-3100-81-xx	3100	2156	2640	2378	2378	1584	4277	1584	3342	B5	2500	10.2	72
ACA 632-3520-81-xx	3520	2449	3000	2702	2702	1800	4860	1800	3798	B5	4500	16.5	75
ACA 632-4310-81-xx	4110	2858	3500	3152	3152	2100	5670	2100	4431	B5	4500	20.8	75
Asymmetrical thyristor supply sections (525...830 V Range, U _N = 830 V)													
ACA 632-3100/1680-81-xx	3100	2156	2640	2378	1290	1584	4277	1584	3342	B5	2500	10.2	72
ACA 632-3520/1680-81-xx	3520	2449	3000	2702	1290	1800	4860	1800	3798	B5	4500	16.5	75
ACA 632-4310/1680-81-xx	4110	2858	3500	3152	1290	2100	5670	2100	4431	B5	4500	20.8	75
12 pulse thyristor supply sections (525...830 V Range, U _N = 830 V)													
ACA 636-3190-81-xx	3193	2221	2721	2451	2451	1632	4408	1632	3183	B4	2x2500	2x6.3	74
ACA 636-5890-81-xx	5889	4096	5018	4520	4520	3010	8126	3010	6350	B5	2x2500	2x10.2	77
ACA 636-8190-81-xx	7806	5430	6652	5991	5991	3990	10773	3990	8419	B5	2x4500	2x20.8	77
12/6 pulse thyristor supply sections (525...830 V Range, U _N = 830 V)													
ACA 637-3190-81-xx	3193	2221	2721	2451	1225	1632	4408	1632	3183	B4	2500	2x6.3	74
ACA 637-5890-81-xx	5889	4096	5018	4520	2260	3010	8126	3010	6350	B5	2500	2x10.2	77
ACA 637-8190-81-xx	7806	5430	6652	5991	2996	3990	10773	3990	8419	B5	4500	2x20.8	77

PDM code 00001749-C

Autotransformer Data

The table below shows the nominal ratings for thyristor supply autotransformers.

Type Marking	Autotransformer					Forward Bridge Type	Reverse Bridge Type
	Type	S_N kVA	S_{rms} kVA	I_1 A	U_1 V		
400 V Range							
6 pulse thyristor supply sections with autotransformer (380...415 V Range, $U_N = 400$ V)							
ACA 634-0200-31-xx	NDAT-08	299	214	416	415	ACN654 0250 5	ACN664 0250 5
ACA 634-0420-31-xx	NDAT-09	677	485	942	415	ACN654 0525 5	ACN664 0525 5
ACA 634-0680-31-xx	NDAT-10	1115	798	1552	415	ACN654 0850 5	ACN664 0850 5
ACA 634-1120-31-xx	NDAT-10	1115	798	1552	415	ACN654 1400 5	ACN664 1400 5
ACA 634-1700-31-xx	NDAT-11	1859	1331	2587	415	ACN654 2120 5	ACN664 2120 5
ACA 634-2100-31-xx	NDAT-11	1859	1331	2587	415	ACN654 2600 5	ACN664 2600 5
12 pulse thyristor supply sections with autotransformer (380...415 V Range, $U_N = 400$ V)							
ACA 638-0800-31-xx	NDAT-09	677	485	942	415	ACN654 0525 5	ACN664 0525 5
ACA 638-1290-31-xx	NDAT-09	677	485	942	415	ACN654 0855 5	ACN664 0855 5
ACA 638-2130-31-xx	NDAT-10	1115	798	1552	415	ACN654 1405 5	ACN664 1405 5
ACA 638-3220-31-xx	NDAT-11	1859	1331	2587	415	ACN654 2120 5	ACN664 2120 5
12/6 pulse thyristor supply sections with autotransformer (380...415 V Range, $U_N = 400$ V)							
ACA 639-0800-31-xx	NDAT-09	677	485	942	415	ACN654 0525 5	ACN664 0525 5
ACA 639-1290-31-xx	NDAT-09	677	485	942	415	ACN654 0855 5	ACN664 0855 5
ACA 639-2130-31-xx	NDAT-10	1115	798	1552	415	ACN654 1405 5	ACN664 1405 5
ACA 639-3220-31-xx	NDAT-11	1859	1331	2587	415	ACN654 2120 5	ACN664 2120 5
500 V Range							
6 pulse thyristor supply sections with autotransformer (380...500 V Range, $U_N = 500$ V)							
ACA 634-0250-51-xx	NDAT-02	331	237	277	690	ACN654 0250 5	ACN664 0375 6
ACA 634-0375-51-xx	NDAT-03	696	498	582	690	ACN654 0375 5	ACN664 0525 6
ACA 634-0850-51-xx	NDAT-04	1126	806	942	690	ACN654 0850 5	ACN664 1400 6
ACA 634-1400-51-xx	NDAT-05	1855	1328	1552	690	ACN654 1400 5	ACN664 2600 6
ACA 634-2120-51-xx	NDAT-05	1855	1328	1552	690	ACN654 2120 5	ACN664 2600 5
ACA 634-2600-51-xx	NDAT-06	3272	2343	2282	690	ACN654 2600 5	ACN664 3600 5
12 pulse thyristor supply sections with autotransformer (380...500 V Range, $U_N = 500$ V)							
ACA 638-1000-51-xx	NDAT-03	696	498	582	690	ACN654 0525 5	ACN664 0525 6
ACA 638-1615-51-xx	NDAT-04	1126	806	942	690	ACN654 0855 5	ACN664 0855 6
ACA 638-2660-51-xx	NDAT-05	1855	1328	1552	690	ACN654 1405 5	ACN664 1405 6
ACA 638-4030-51-xx	NDAT-06	3272	2343	2738	690	ACN654 2120 5	ACN664 2600 6
ACA 638-4700-51-xx	NDAT-06	3272	2343	2738	690	ACN654 2600 5	ACN664 2600 6
12/6 pulse thyristor supply sections with autotransformer (380...500 V Range, $U_N = 500$ V)							
ACA 639-1000-51-xx	NDAT-03	696	498	582	690	ACN654 0525 5	ACN664 0525 6
ACA 639-1615-51-xx	NDAT-04	1126	806	942	690	ACN654 0855 5	ACN664 0855 6
ACA 639-2660-51-xx	NDAT-05	1855	1328	1552	690	ACN654 1405 5	ACN664 1405 6
ACA 639-4030-51-xx	NDAT-06	3272	2343	2738	690	ACN654 2120 5	ACN664 2600 6
ACA 639-4700-51-xx	NDAT-06	3272	2343	2738	690	ACN654 2600 5	ACN664 2600 6
690 V Range							
6 pulse thyristor supply sections with autotransformer (525...690 V Range, $U_N = 690$ V)							
ACA 634-1400-61-xx	NDAT-05	1855	1328	1552	690	ACN654 1400 6	ACN664 1680 8
ACA 634-2600-61-xx	NDAT-06	3272	2343	2282	690	ACN654 2600 6	ACN664 3100 8
ACA 634-3600-61-xx	NDAT-06	3272	2343	2282	690	ACN654 3600 6	ACN664 4210 8
12 pulse thyristor supply sections with autotransformer (525...690 V Range, $U_N = 690$ V)							
ACA 638-1615-61-xx	NDAT-04	1126	806	942	690	ACN654 0855 6	ACN664 1680 8
ACA 638-2660-61-xx	NDAT-05	1855	1328	1552	690	ACN654 1405 6	ACN664 1680 8
ACA 638-4950-61-xx	NDAT-06	3272	2343	2738	690	ACN654 2600 6	ACN664 3100 8
ACA 638-6500-61-xx	NDAT-06	3272	2343	2738	690	ACN654 3600 6	ACN664 3100 8
12/6 pulse thyristor supply sections with autotransformer (525...690 V Range, $U_N = 690$ V)							
ACA 639-1615-61-xx	NDAT-04	1126	806	942	690	ACN654 0855 6	ACN664 1680 8
ACA 639-2660-61-xx	NDAT-05	1855	1328	1552	690	ACN654 1405 6	ACN664 1680 8
ACA 639-4950-61-xx	NDAT-06	3272	2343	2738	690	ACN654 2600 6	ACN664 3100 8
ACA 639-6500-61-xx	NDAT-06	3272	2343	2738	690	ACN654 3600 6	ACN664 3100 8

PDM code 00001749-C

Dimensions and Weights 400 V The table below shows the dimensions and weights of the 400 V range supply sections. See notes on page A-2.

Type Marking	Height mm	Bottom Entry: Width mm	Top Entry: Width mm	Depth mm	Bottom Entry: Weight kg	Top Entry: Weight kg	Width (EMC) mm	Weight (EMC) kg
Diode supply sections (380...415 V Range)								
ACA 631-0140-31-xx	2065	400	800 (400+400)	600	300	420	400	100
ACA 631-0200-31-xx	2065	400	800 (400+400)	600	300	420	400	100
ACA 631-0300-31-xx	2065	600	1200 (600+600)	600	380	510	400	120
ACA 631-0420-31-xx	2065	600	1200 (600+600)	600	380	510	600	120
ACA 631-0680-31-xx	2065	1600 (600+400+600)	1600 (600+400+600)	600	1300	1300	600	150
ACA 631-1120-31-xx	2130	1600 (600+400+600)	1600 (600+400+600)	600	1300	1300	–	–
ACA 631-1700-31-xx	2130	1600 (600+400+600)	1600 (600+400+600)	600	1600	1600	–	–
ACA 631-2100-31-xx	2130	1600 (600+400+600)	1600 (600+400+600)	600	1600	1600	–	–
Thyristor supply sections (380...415 V Range)								
ACA 632-0015-31-xx	2065	400	400	600	250	250	–	–
ACA 632-0030-31-xx	2065	400	400	600	250	250	–	–
ACA 632-0040-31-xx	2065	400	400	600	250	250	–	–
ACA 632-0070-31-xx	2065	400	400	600	250	250	–	–
ACA 632-0140-31-xx	2065	400	800 (400+400)	600	300	420	–	–
ACA 632-0200-31-xx	2065	400	800 (400+400)	600	300	420	–	–
ACA 632-0300-31-xx	2065	600	1200 (600+600)	600	380	510	–	–
ACA 632-0420-31-xx	2065	600	1200 (600+600)	600	380	510	–	–
ACA 632-0680-31-xx	2130	2200 (600+400+600+600)	2200 (600+400+600+600)	600	1500	1500	–	–
ACA 632-1120-31-xx	2130	2200 (600+400+600+600)	2200 (600+400+600+600)	600	1500	1500	–	–
ACA 632-1700-31-xx	2130	2200 (600+400+600+600)	2200 (600+400+600+600)	600	1900	1900	–	–
ACA 632-2100-31-xx	2130	2200 (600+400+600+600)	2200 (600+400+600+600)	600	1900	1900	–	–
Asymmetrical thyristor supply sections (380...415 V Range, $U_N = 400$ V)								
ACA 632-1700/0680-31-xx	2130	2200 (600+400+600+600)	2200 (600+400+600+600)	600	1900	1900	–	–
ACA 632-1700/1120-31-xx	2130	2200 (600+400+600+600)	2200 (600+400+600+600)	600	1900	1900	–	–
ACA 632-2100/0680-31-xx	2130	2200 (600+400+600+600)	2200 (600+400+600+600)	600	1900	1900	–	–
ACA 632-2100/1120-31-xx	2130	2200 (600+400+600+600)	2200 (600+400+600+600)	600	1900	1900	–	–
12 pulse diode supply sections (380...415 V Range)								
ACA 633-0280-31-xx	2065	800 (2x400)	1600 (2x(400+400))	600	480	720	–	–
ACA 633-0400-31-xx	2065	800 (2x400)	1600 (2x(400+400))	600	480	720	–	–
ACA 633-0600-31-xx	2065	1200 (2x600)	2400 (2x(600+600))	600	640	900	–	–
ACA 633-0840-31-xx	2065	1200 (2x600)	2400 (2x(600+600))	600	640	900	–	–
ACA 633-1360-31-xx	2130	3200 (2x(600+400+600))	3200 (2x(600+400+600))	600	2400	2400	–	–
ACA 633-2240-31-xx	2130	3200 (2x(600+400+600))	3200 (2x(600+400+600))	600	2400	2400	–	–
ACA 633-3400-31-xx	2130	3200 (2x(600+400+600))	3200 (2x(600+400+600))	600	3000	3000	–	–
6 pulse thyristor supply sections with autotransformer (380...415 V Range, $U_N = 400$ V)								
ACA 634-0200-31-xx	2065	1400 (400+600+400)	1800 (400+400+600+400)	600	950	1050	–	–
ACA 634-0420-31-xx	2065	2000 (600+800+600)	2600 (600+600+800+600)	600	1250	1400	–	–
ACA 634-0680-31-xx	2130	3000 (600+400+600+800+600)	3000 (600+400+600+800+600)	600	2000	2000	–	–
ACA 634-1120-31-xx	2130	3000 (600+400+600+800+600)	3000 (600+400+600+800+600)	600	2000	2000	–	–
ACA 634-1700-31-xx	2130	3200 (600+400+600+1000+600)	3200 (600+400+600+1000+600)	600	2700	2700	–	–
ACA 634-2100-31-xx	2130	3200 (600+400+600+1000+600)	3200 (600+400+600+1000+600)	600	2700	2700	–	–
12 pulse thyristor supply sections (380...415 V Range, $U_N = 400$ V)								
ACA 636-0800-31-xx	2065	2x600	2x1200 (2x(600+600))	600	760	1020	–	–
ACA 636-1290-31-xx	2130	4600	4600	600	3100	3100	–	–
ACA 636-2130-31-xx	2130	4600	4600	600	3100	3100	–	–
ACA 636-3220-31-xx	2130	4600	4600	600	3100	3100	–	–
12 pulse thyristor supply sections with autotransformer (380...415 V Range, $U_N = 400$ V)								
ACA 638-0800-31-xx	2065	4200	5400	600	2560	2880	–	–
ACA 638-1290-31-xx	2130	6200	6200	600	4100	4100	–	–
ACA 638-2130-31-xx	2130	6200	6200	600	4100	4100	–	–
ACA 638-3220-31-xx	2130	6600	6600	600	5500	5500	–	–
12/6 pulse thyristor supply sections with autotransformer (380...415 V Range, $U_N = 400$ V)								
ACA 639-0800-31-xx	2065	2600 (600+800+600+600)	3800	600	1640	1900	–	–
ACA 639-1290-31-xx	2130	4800	4800	600	3400	3400	–	–
ACA 639-2130-31-xx	2130	4800	4800	600	3400	3400	–	–
ACA 639-3220-31-xx	2130	5000	5000	600	4100	4100	–	–

PDM code 00001749-C

Dimensions and Weights 500 V The table below shows the dimensions and weights of the 500 V range supply sections. See notes on page A-2.

Type Marking	Height mm	Bottom Entry: Width mm	Top Entry: Width mm	Depth mm	Bottom Entry: Weight kg	Top Entry: Weight kg	Width (EMC) mm	Weight (EMC) kg
Diode supply sections (440...500 V Range)								
ACA 631-0175-51-xx	2065	400	800 (400+400)	600	300	420	400	100
ACA 631-0250-51-xx	2065	400	800 (400+400)	600	300	420	400	100
ACA 631-0375-51-xx	2065	600	1200 (600+600)	600	380	510	600	120
ACA 631-0525-51-xx	2065	600	1200 (600+600)	600	380	510	600	120
ACA 631-0850-51-xx	2130	1600 (600+400+600)	1600 (600+400+600)	600	1300	1300	600	150
ACA 631-1400-51-xx	2130	1600 (600+400+600)	1600 (600+400+600)	600	1300	1300	–	–
ACA 631-2120-51-xx	2130	1600 (600+400+600)	1600 (600+400+600)	600	1600	1600	–	–
ACA 631-2600-51-xx	2130	1600 (600+400+600)	1600 (600+400+600)	600	1600	1600	–	–
Thyristor supply sections (440...500 V Range)								
ACA 632-0020-51-xx	2065	400	400	600	250	250	–	–
ACA 632-0035-51-xx	2065	400	400	600	250	250	–	–
ACA 632-0050-51-xx	2065	400	400	600	250	250	–	–
ACA 632-0090-51-xx	2065	400	400	600	250	250	–	–
ACA 632-0175-51-xx	2065	400	800 (400+400)	600	300	420	–	–
ACA 632-0250-51-xx	2065	400	800 (400+400)	600	300	420	–	–
ACA 632-0375-51-xx	2065	600	1200 (600+600)	600	380	510	–	–
ACA 632-0525-51-xx	2065	600	1200 (600+600)	600	380	510	–	–
ACA 632-0850-51-xx	2130	2200 (600+400+600+600)	2200 (600+400+600+600)	600	1500	1500	–	–
ACA 632-1400-51-xx	2130	2200 (600+400+600+600)	2200 (600+400+600+600)	600	1500	1500	–	–
ACA 632-2120-51-xx	2130	2200 (600+400+600+600)	2200 (600+400+600+600)	600	1900	1900	–	–
ACA 632-2600-51-xx	2130	2200 (600+400+600+600)	2200 (600+400+600+600)	600	1900	1900	–	–
Asymmetrical thyristor supply sections (380...500 V Range, $U_N = 500$ V)								
ACA 632-2120/0850-51-xx	2130	2200 (600+400+600+600)	2200 (600+400+600+600)	600	1900	1900	–	–
ACA 632-2120/1400-51-xx	2130	2200 (600+400+600+600)	2200 (600+400+600+600)	600	1900	1900	–	–
ACA 632-2600/0850-51-xx	2130	2200 (600+400+600+600)	2200 (600+400+600+600)	600	1900	1900	–	–
ACA 632-2600/1400-51-xx	2130	2200 (600+400+600+600)	2200 (600+400+600+600)	600	1900	1900	–	–
12 pulse diode supply sections (440...500 V Range)								
ACA 633-0350-51-xx	2065	800 (2x400)	1600 (2x(400+400))	600	480	720	–	–
ACA 633-0500-51-xx	2065	800 (2x400)	1600 (2x(400+400))	600	480	720	–	–
ACA 633-0750-51-xx	2065	1200 (2x600)	2400 (2x(600+600))	600	640	900	–	–
ACA 633-1050-51-xx	2065	1200 (2x600)	2400 (2x(600+600))	600	640	900	–	–
ACA 633-1700-51-xx	2130	3200 (2x(600+400+600))	3200 (2x(600+400+600))	600	2400	2400	–	–
ACA 633-2800-51-xx	2130	3200 (2x(600+400+600))	3200 (2x(600+400+600))	600	2400	2400	–	–
ACA 633-4240-51-xx	2130	3200 (2x(600+400+600))	3200 (2x(600+400+600))	600	3000	3000	–	–
6 pulse thyristor supply sections with autotransformer (380...500 V Range, $U_N = 500$ V)								
ACA 634-0250-51-xx	2065	1400 (400+600+400)	1800 (400+400+600+400)	600	950	1050	–	–
ACA 634-0375-51-xx	2065	2000 (600+800+600)	2600 (600+600+800+600)	600	1250	1400	–	–
ACA 634-0850-51-xx	2130	3000 (600+400+600+800+600)	3000 (600+400+600+800+600)	600	2000	2000	–	–
ACA 634-1400-51-xx	2130	3200 (600+400+600+1000+600)	3200 (600+400+600+1000+600)	600	2700	2700	–	–
ACA 634-2120-51-xx	2130	3200 (600+400+600+1000+600)	3200 (600+400+600+1000+600)	600	2700	2700	–	–
ACA 634-2600-51-xx	2130	3700 (600+400+600+1500+600)	3700 (600+400+600+1500+600)	600	3700	3700	–	–
12 pulse thyristor supply sections (380...500 V Range, $U_N = 500$ V)								
ACA 636-1000-51-xx	2065	2x600	2x1200 (600+600)	600	760	1020	–	–
ACA 636-1615-51-xx	2130	4600	4600	600	3100	3100	–	–
ACA 636-2660-51-xx	2130	4600	4600	600	3100	3100	–	–
ACA 636-4030-51-xx	2130	4600	4600	600	3100	3100	–	–
ACA 636-4700-51-xx	2130	4600	4600	600	3100	3100	–	–
12 pulse thyristor supply sections with autotransformer (380...500 V Range, $U_N = 500$ V)								
ACA 638-1000-51-xx	2065	4200	5400	600	2460	2880	–	–
ACA 638-1615-51-xx	2130	6200	6200	600	4100	4100	–	–
ACA 638-2660-51-xx	2130	6600	6600	600	5500	5500	–	–
ACA 638-4030-51-xx	2130	8000	8000	600	7500	7500	–	–
ACA 638-4700-51-xx	2130	8000	8000	600	7500	7500	–	–
12/6 pulse thyristor supply sections with autotransformer (380...500 V Range, $U_N = 500$ V)								
ACA 639-1000-51-xx	2065	2600 (600+800+600+600)	3800	600	1640	1900	–	–
ACA 639-1615-51-xx	2130	4800	4800	600	3400	3400	–	–
ACA 639-2660-51-xx	2130	5000	5000	600	4100	4100	–	–
ACA 639-4030-51-xx	2130	5700	5700	600	5100	5100	–	–
ACA 639-4700-51-xx	2130	5700	5700	600	5100	5100	–	–

PDM code 00001749-C

Dimensions and Weights 690 V

The table below shows the dimensions and weights of the 690 V range supply sections. See notes on page A-2.

Type Marking	Height mm	Bottom Entry: Width mm	Top Entry: Width mm	Depth mm	Bottom Entry: Weight kg	Top Entry: Weight kg	Width (EMC) mm	Weight (EMC) kg
Diode supply sections (525...690 V Range)								
ACA 631-0090-61-xx	2065	400	800	600	300	420	400	100
ACA 631-0175-61-xx	2065	400	800 (400+400)	600	300	420	400	100
ACA 631-0250-61-xx	2065	400	800 (400+400)	600	300	420	400	100
ACA 631-0375-61-xx	2065	600	1200 (600+600)	600	380	510	600	120
ACA 631-0525-61-xx	2065	600	1200 (600+600)	600	380	510	600	120
ACA 631-0850-61-xx	2130	1600 (600+400+600)	1600 (600+400+600)	600	1300	1300	600	150
ACA 631-1400-61-xx	2130	1600 (600+400+600)	1600 (600+400+600)	600	1300	1300	-	-
ACA 631-2600-61-xx	2130	1600 (600+400+600)	1600 (600+400+600)	600	1600	1600	-	-
ACA 631-3600-61-xx	2130	1600 (600+400+600)	1600 (600+400+600)	600	1600	1600	-	-
Thyristor supply sections (525...690 V Range)								
ACA 632-0090-61-xx	2065	400	800 (400+400)	600	300	420	-	-
ACA 632-0175-61-xx	2065	400	800 (400+400)	600	300	420	-	-
ACA 632-0250-61-xx	2065	400	800 (400+400)	600	300	420	-	-
ACA 632-0375-61-xx	2065	600	1200 (600+600)	600	380	510	-	-
ACA 632-0525-61-xx	2065	600	1200 (600+600)	600	380	510	-	-
ACA 632-0850-61-xx	2130	2200 (600+400+600+600)	2200 (600+400+600+600)	600	1500	1500	-	-
ACA 632-1400-61-xx	2130	2200 (600+400+600+600)	2200 (600+400+600+600)	600	1500	1500	-	-
ACA 632-2600-61-xx	2130	2200 (600+400+600+600)	2200 (600+400+600+600)	600	1900	1900	-	-
ACA 632-3600-61-xx	2130	2200 (600+400+600+600)	2200 (600+400+600+600)	600	1900	1900	-	-
Asymmetrical thyristor supply sections (525...690 V Range, $U_N = 690$ V)								
ACA 632-2600/0850-61-xx	2130	2200 (600+400+600+600)	2200 (600+400+600+600)	600	1900	1900	-	-
ACA 632-2600/1400-61-xx	2130	2200 (600+400+600+600)	2200 (600+400+600+600)	600	1900	1900	-	-
ACA 632-3600/0850-61-xx	2130	2200 (600+400+600+600)	2200 (600+400+600+600)	600	1900	1900	-	-
ACA 632-3600/1400-61-xx	2130	2200 (600+400+600+600)	2200 (600+400+600+600)	600	1900	1900	-	-
ACA 632-3600/2600-61-xx	2130	2200 (600+400+600+600)	2200 (600+400+600+600)	600	1900	1900	-	-
12 pulse diode supply sections (525...690 V Range)								
ACA 633-0180-61-xx	2065	800 (2x400)	1600 (2x(400+400))	600	480	720	-	-
ACA 633-0350-61-xx	2065	800 (2x400)	1600 (2x(400+400))	600	480	720	-	-
ACA 633-0500-61-xx	2065	800 (2x400)	1600 (2x(400+400))	600	480	720	-	-
ACA 633-0750-61-xx	2065	1200 (2x600)	2400 (2x(600+600))	600	640	900	-	-
ACA 633-1050-61-xx	2065	1200 (2x600)	2400 (2x(600+600))	600	640	900	-	-
ACA 633-1700-61-xx	2130	3200 (2x(600+400+600))	3200 (2x(600+400+600))	600	2400	2400	-	-
ACA 633-2800-61-xx	2130	3200 (2x(600+400+600))	3200 (2x(600+400+600))	600	2400	2400	-	-
ACA 633-5200-61-xx	2130	3200 (2x(600+400+600))	3200 (2x(600+400+600))	600	3000	3000	-	-
6 pulse thyristor supply sections with autotransformer (525...690 V Range, $U_N = 690$ V)								
ACA 634-1400-61-xx	2130	3200 (600+400+600+1000+600)	3200 (600+400+600+1000+600)	600	2700	2700	-	-
ACA 634-2600-61-xx	2130	3700 (600+400+600+1500+600)	3700 (600+400+600+1500+600)	600	3700	3700	-	-
ACA 634-3600-61-xx	2130	3700 (600+400+600+1500+600)	3700 (600+400+600+1500+600)	600	3700	3700	-	-
12 pulse thyristor supply sections (525...690 V Range, $U_N = 690$ V)								
ACA 636-1000-61-xx	2065	2x600	2x1200 (600+600)	600	760	1020	-	-
ACA 636-1615-61-xx	2130	4600	4600	600	3100	3100	-	-
ACA 636-2660-61-xx	2130	4600	4600	600	3100	3100	-	-
ACA 636-4950-61-xx	2130	4600	4600	600	3100	3100	-	-
ACA 636-6500-61-xx	2130	4600	4600	600	3100	3100	-	-
12 pulse thyristor supply sections with autotransformer (525...690 V Range, $U_N = 690$ V)								
ACA 638-1615-61-xx	2130	6200	6200	600	4100	4100	-	-
ACA 638-2660-61-xx	2130	6600	6600	600	5500	5500	-	-
ACA 638-4950-61-xx	2130	8000	8000	600	7500	7500	-	-
ACA 638-6500-61-xx	2130	8000	8000	600	7500	7500	-	-
12/6 pulse thyristor supply sections with autotransformer (525...690 V Range, $U_N = 690$ V)								
ACA 639-1615-61-xx	2130	4800	4800	600	3400	3400	-	-
ACA 639-2660-61-xx	2130	5000	5000	600	4100	4100	-	-
ACA 639-4950-61-xx	2130	5700	5700	600	5100	5100	-	-
ACA 639-6500-61-xx	2130	5700	5700	600	5100	5100	-	-

PDM code 00001749-C

Dimensions and Weights 830 V The table below shows the dimensions and weights of the 830 V supply sections. See notes on page A-2.

Type Marking	Height mm	Bottom Entry: Width mm	Top Entry: Width mm	Depth mm	Bottom Entry: Weight kg	Top Entry: Weight kg	Width (EMC) mm	Weight (EMC) kg
Thyristor supply sections (830 V)								
ACA 632-1680-81-xx	2130	2200 (600+400+600+600)	2200 (600+400+600+600)	600	1500	1500	–	–
ACA 632-3100-81-xx	2130	2200 (600+400+600+600)	2200 (600+400+600+600)	600	1500	1500	–	–
ACA 632-3520-81-xx	2130	2200 (600+400+600+600)	2200 (600+400+600+600)	600	1900	1900	–	–
ACA 632-4210-81-xx	2130	2200 (600+400+600+600)	2200 (600+400+600+600)	600	1900	1900	–	–
Asymmetrical thyristor supply sections (525...830 V Range, $U_N = 830$ V)								
ACA 632-3100/1680-81-xx	2130	2200 (600+400+600+600)	2200 (600+400+600+600)	600	1500	1500	–	–
ACA 632-3520/1680-81-xx	2130	2200 (600+400+600+600)	2200 (600+400+600+600)	600	1900	1900	–	–
ACA 632-4310/1680-81-xx	2130	2200 (600+400+600+600)	2200 (600+400+600+600)	600	1900	1900	–	–
12 pulse thyristor supply sections (525...830 V Range, $U_N = 830$ V)								
ACA 636-3190-81-xx	2130	4600	4600	600	3100	3100	–	–
ACA 636-5890-81-xx	2130	4600	4600	600	3100	3100	–	–
ACA 636-8190-81-xx	2130	4600	4600	600	3100	3100	–	–
12/6 pulse thyristor supply sections (525...830 V Range, $U_N = 830$ V)								
ACA 637-3190-81-xx	2130	4000	4000	600	2900	2900	–	–
ACA 637-5890-81-xx	2130	4000	4000	600	2900	2900	–	–
ACA 637-8190-81-xx	2130	4000	4000	600	2900	2900	–	–

PDM code 00001749-C

Drive Section Tables

The following tables specify the ratings for the drive sections.

Notes The notes concerning the following drive section tables are listed below.

P_{loss} P_{loss} is the heat loss of a unit with basic options.

Noise Level Noise level applies to echoless room.

Height The height of the cabinet for IP 21/22/42 classification is 2065 mm up to frame type R7i. The height of frame type R8i and above is 2130 mm. Cabinet height is 2072 mm for IP 54R classification.

Depth The depth of the cabinet is 600 mm.

Width and Weight

Note	Description	Weight kg
1	200 mm is added with the top exit	40
2	400 mm is added with the top exit	110
3	600 mm is added with the top exit	160
4	800 mm is added with the top exit and/or common motor connection terminals	230
5	600 mm is added with the top exit and/or common motor connection terminals	190
6	The width is 400 mm with no options and 600 mm when optional devices are included. 600 mm is added when more than one inverter unit is used in the drive section.	
7	200 mm wide joining cabinet is added (max. transportation length is 4000 mm)	40

PDM code 00004863-D

Ratings 400 V The table below shows the nominal ratings for the 400 V range drive sections.

Type Marking	Nominal Ratings			Duty Cycle (10 s / 60 s)		Duty Cycle (1 min / 5 min)		Frame type	P_{loss} kW	Air flow m ³ /h	Noise level dBA	Width mm	Weight kg	Notes
	S_N kVA	P_N kW	I_{2N} A	I_{2base} A	I_{2max} A	I_{2base} A	I_{2max} A							
Drive sections (380...500 V Range, $U_N = 400$ V)														
ACA 610-05/00/00-3	5	3	7.6	6.2	12	6.2	9.3	R2i	0.08	40	48	400	170	1
ACA 610-05/05/00-3								2xR2i	0.16	80	50	400 or 600	210	1, 6
ACA 610-05/05/05-3								3xR2i	0.24	120	51	400 or 600	220	1, 6
ACA 610-06/00/00-3	6	4	11	7.6	15	7.6	11	R2i	0.09	40	48	400	170	1
ACA 610-06/06/00-3								2xR2i	0.18	80	50	400 or 600	210	1, 6
ACA 610-06/06/06-3								3xR2i	0.27	120	51	400 or 600	220	1, 6
ACA 610-09/00/00-3	9	5.5	15	11	22	11	17	R2i	0.14	40	48	400	170	1
ACA 610-09/09/00-3								2xR2i	0.28	80	50	400 or 600	210	1, 6
ACA 610-09/09/09-3								3xR2i	0.42	120	51	400 or 600	220	1, 6
ACA 610-11/00/00-3	11	7.5	18	15	30	15	23	R3i	0.17	60	48	400	180	1
ACA 610-11/11/00-3								2xR3i	0.34	120	50	400 or 600	220	1, 6
ACA 610-11/11/11-3								3xR3i	0.51	180	51	400 or 600	230	1, 6
ACA 610-16/00/00-3	16	11	24	18	36	18	27	R3i	0.24	60	48	400	180	1
ACA 610-16/16/00-3								2xR3i	0.48	120	50	400 or 600	220	1, 6
ACA 610-16/16/16-3								3xR3i	0.72	180	51	400 or 600	230	1, 6
ACA 610-020/000-3	20	15	32	24	48	24	36	R4i	0.30	70	54	400	190	1
ACA 610-020/020-3								2xR4i	0.60	140	54	400 or 600	240	1, 6
ACA 610-025/000-3	25	18.5	41	32	64	32	48	R4i	0.38	100	54	400	190	1
ACA 610-025/025-3								2xR4i	0.76	200	54	400 or 600	240	1, 6
ACA 610-030/000-3	30	22	47	41	82	41	62	R5i	0.45	260	54	400	190	1
ACA 610-030/030-3								2xR5i	0.90	520	54	400 or 600	240	1, 6
ACA 610-040/000-3	40	30	62	47	94	47	71	R5i	0.60	260	54	400	190	1
ACA 610-040/040-3								2xR5i	1.20	520	54	400 or 600	240	1, 6
ACA 610-050/000-3	50	37	76	62	124	62	93	R5i	0.75	260	54	400	190	1
ACA 610-050/050-3								2xR5i	1.50	520	54	400 or 600	240	1, 6
ACA 610-060/000-3	60	45	89	76	152	76	114	R6i	0.90	480	64	400	200	1
ACA 610-060/060-3								2xR6i	1.80	960	68	600	250	1
ACA 610-070/000-3	70	55	112	89	178	89	134	R6i	1.05	480	64	400	200	1
ACA 610-070/070-3								2xR6i	2.10	960	68	600	250	1
ACA 610-100/000-3	100	75	147	112	224	112	168	R7i	1.50	480	64	400	200	1
ACA 610-100/100-3								2xR7i	3.00	960	68	600	250	1
ACA 610-120/000-3	120	90	178	147	294	147	221	R7i	1.80	480	64	400	200	1
ACA 610-120/120-3								2xR7i	3.60	960	68	600	250	1
ACA 610-0185-3	180	135	259	178	356	194	291	R8i	2.70	1550	61	600	250	2
ACA 610-0225-3	220	165	312	216	432	234	351	R8i	3.30	1550	61	600	250	2
ACA 610-0265-3	260	200	379	260	520	284	426	R8i	3.90	1550	61	600	250	2
ACA 610-0335-3	330	250	474	316	632	356	533	R9i	4.95	1550	61	600	270	2
ACA 610-0405-3	400	315	576	395	790	432	648	R9i	6.00	1550	61	600	270	2
ACA 610-0500-3	500	400	720	494	988	540	810	R10i	7.50	3100	66	1000	450	2
ACA 610-0630-3	630	500	907	600	1200	680	1020	R11i	9.45	3100	66	1000	480	2
ACA 610-0765-3	760	630	1094	751	1502	821	1231	R11i	11.40	3100	66	1000	480	2
ACA 610-0935-3	930	-	1336	901	1802	1002	1503	R12i	13.95	4650	69	1500	950	3
ACA 610-1125-3	1120	-	1624	1126	2252	1218	1827	R12i	16.80	4650	69	1500	950	3
ACA 610-1440-3	1440	-	2079	1501	3002	1559	2339	2xR11i	21.60	6200	69	2x1000	1200	3, 5
ACA 610-1775-3	1770	-	2558	1801	3602	1919	2878	2xR12i	26.55	9300	71	2x1500	1900	4
ACA 610-2145-3	2140	-	3085	2252	4504	2314	3471	2xR12i	32.10	9300	71	2x1500	1900	4
ACA 610-2340-3	2340	-	3374	2402	4804	2531	3796	4xR11i	35.10	12400	71	4x1000	2400	4
ACA 610-2820-3	2820	-	4070	3002	6004	3053	4579	4xR11i	42.30	12400	71	4x1000	2400	4

PDM code 00004863-C

Ratings 500 V The table below shows the nominal ratings for the 500 V range drive sections.

Type Marking	Nominal Ratings			Duty Cycle (10 s / 60 s)		Duty Cycle (1 min / 5 min)		Frame type	P _{loss} kW	Air flow m ³ /h	Noise level dBA	Width mm	Weight kg	Notes
	S _N kVA	P _N kW	I _{2N} A	I _{2base} A	I _{2max} A	I _{2base} A	I _{2max} A							
Drive sections(380...500 V Range, U _N = 500 V)														
ACA 610-06/00/00-5	6	4	7.6	6.2	12	6.2	9.3	R2i	0.09	40	48	400	170	1,
ACA 610-06/06/00-5								2xR2i	0.18	80	50	400 or 600	210	1, 6
ACA 610-06/06/06-5								3xR2i	0.27	120	51	400 or 600	220	1, 6
ACA 610-09/00/00-5	9	5.5	11	7.6	15	7.6	11	R2i	0.14	40	48	400	170	1
ACA 610-09/09/00-5								2xR2i	0.28	80	50	400 or 600	210	1, 6
ACA 610-09/09/09-5								3xR2i	0.42	120	51	400 or 600	220	1, 6
ACA 610-11/00/00-5	11	7.5	15	11	22	11	17	R2i	0.17	40	48	400	170	1
ACA 610-11/11/00-5								2xR2i	0.34	80	50	400 or 600	210	1, 6
ACA 610-11/11/11-5								3xR2i	0.51	120	51	400 or 600	220	1, 6
ACA 610-16/00/00-5	16	11	18	15	30	15	23	R3i	0.24	60	48	400	180	1
ACA 610-16/16/00-5								2xR3i	0.48	120	50	400 or 600	220	1, 6
ACA 610-16/16/16-5								3xR3i	0.72	180	51	400 or 600	230	1, 6
ACA 610-20/00/00-5	20	15	24	18	36	18	27	R3i	0.30	60	48	400	180	1
ACA 610-20/20/00-5								2xR3i	0.60	120	50	400 or 600	220	1, 6
ACA 610-20/20/20-5								3xR3i	0.90	180	51	400 or 600	230	1, 6
ACA 610-025/000-5	25	18.5	31	24	48	24	36	R4i	0.38	70	54	400 or 600	240	1, 6
ACA 610-025/025-5								2xR4i	0.76	140	54	400	190	1
ACA 610-030/000-5	30	22	41	31	62	31	47	R4i	0.45	100	54	400 or 600	240	1, 6
ACA 610-030/030-5								2xR4i	0.90	200	54	400	190	1
ACA 610-040/000-5	40	30	47	41	82	41	62	R5i	0.60	260	54	400 or 600	240	1, 6
ACA 610-040/040-5								2xR5i	1.20	520	54	400	190	1
ACA 610-050/000-5	50	37	58	47	94	47	71	R5i	0.75	260	54	400 or 600	240	1, 6
ACA 610-050/050-5								2xR5i	1.50	520	54	400	190	1
ACA 610-060/000-5	60	45	65	58	116	58	87	R5i	0.90	260	54	400 or 600	240	1, 6
ACA 610-060/060-5								2xR5i	1.80	520	54	400	190	1
ACA 610-070/000-5	70	55	84	65	130	65	98	R6i	1.05	480	64	400	200	1
ACA 610-070/070-5								2xR6i	2.10	960	68	600	250	1
ACA 610-100/000-5	100	75	112	84	168	84	126	R6i	1.50	480	64	400	200	1
ACA 610-100/100-5								2xR6i	3.00	960	68	600	250	1
ACA 610-120/000-5	120	90	135	112	224	112	168	R7i	1.80	480	64	400	200	1
ACA 610-120/120-5								2xR7i	3.60	960	68	600	250	1
ACA 610-140/000-5	140	110	164	135	270	135	203	R7i	2.10	480	64	400	200	1
ACA 610-140/140-5								2xR7i	4.20	960	68	600	250	1
ACA 610-0215-5	210	160	246	164	328	185	277	R8i	3.15	1550	61	600	250	2
ACA 610-0255-5	250	200	295	200	400	221	332	R8i	3.75	1550	61	600	250	2
ACA 610-0325-5	320	250	368	240	480	276	414	R8i	4.80	1550	61	600	250	2
ACA 610-0395-5	390	315	448	300	600	336	504	R9i	5.85	1550	61	600	270	2
ACA 610-0495-5	490	400	565	365	730	424	636	R9i	7.35	1550	61	600	270	2
ACA 610-0610-5	610	500	700	456	912	525	788	R10i	9.15	3100	66	1000	450	2
ACA 610-0770-5	770	630	887	570	1140	665	998	R11i	11.55	3100	66	1000	480	2
ACA 610-0935-5	930	-	1073	694	1388	805	1207	R11i	13.95	3100	66	1000	480	2
ACA 610-1095-5	1090	-	1263	855	1710	947	1421	R12i	16.35	4650	69	1500	950	3
ACA 610-1385-5	1380	-	1593	1040	2080	1195	1792	R12i	20.70	4650	69	1500	950	3
ACA 610-1760-5	1760	-	2039	1387	2774	1529	2294	2xR11i	26.40	6200	69	2x1000	1200	3, 5
ACA 610-2165-5	2160	-	2501	1710	3420	1876	2814	2xR12i	32.40	9300	71	2x1500	1900	4
ACA 610-2625-5	2620	-	3026	2081	4162	2270	3404	2xR12i	39.30	9300	71	2x1500	1900	4
ACA 610-2850-5	2850	-	3300	2280	4560	2475	3713	4xR11i	42.75	12400	71	4x1000	2400	4, 7
ACA 610-3450-5	3450	-	3992	2774	5548	2994	4491	4xR11i	51.75	12400	71	4x1000	2400	4, 7

PDM code 00004863-C

Ratings 690 V The table below shows the nominal ratings for the 690 V range drive sections.

Type Marking	Nominal Ratings			Duty Cycle (10 s / 60 s)		Duty Cycle (1 min / 5 min)		Frame type	P_{loss} kW	Air flow m ³ /h	Noise level dBA	Width mm	Weight kg	Notes
	S_N kVA	P_N kW	I_{2N} A	I_{2base} A	I_{2max} A	I_{2base} A	I_{2max} A							
Drive sections (525...690 V Range, $U_N = 690$ V)														
ACA 610-09/00/00-6	9	5.5	7.6	6.2	12	6.2	9	R3i	0,14	60	48	400	170	1
ACA 610-09/09/00-6								2xR3i	0,28	120	50	400 or 600	210	1, 6
ACA 610-09/09/09-6								3xR3i	0,42	180	51	400 or 600	220	1, 6
ACA 610-11/00/00-6	11	8	10	8.7	17	8.7	13	R3i	0,17	60	48	400	170	1
ACA 610-11/11/00-6								2xR3i	0,34	120	50	400 or 600	210	1, 6
ACA 610-11/11/11-6								3xR3i	0,51	180	51	400 or 600	220	1, 6
ACA 610-16/00/00-6	16	11	14	10	20	10	15	R3i	0,24	60	48	400	170	1
ACA 610-16/16/00-6								2xR3i	0,48	120	50	400 or 600	210	1, 6
ACA 610-16/16/16-6								3xR3i	0,72	180	51	400 or 600	220	1, 6
ACA 610-20/00/00-6	20	15	20	15	30	15	23	R3i	0,30	60	48	400	170	1
ACA 610-20/20/00-6								2xR3i	0,60	120	50	400 or 600	210	1, 6
ACA 610-20/20/20-6								3xR3i	0,90	180	51	400 or 600	220	1, 6
ACA 610-025/000-6	25	19	25	20	40	20	30	R4i	0,38	70	54	400	240	1, 6
ACA 610-025/025-6								2xR4i	0,76	140	54	400 or 600	190	1
ACA 610-030/000-6	30	22	28	25	50	25	38	R4i	0,45	100	54	400	240	1, 6
ACA 610-030/030-6								2xR4i	0,90	200	54	400 or 600	190	1
ACA 610-040/000-6	40	30	36	28	56	28	42	R5i	0,60	260	54	400	240	1, 6
ACA 610-040/040-6								2xR5i	1,20	520	54	400 or 600	190	1
ACA 610-050/000-6	50	37	44	36	72	36	54	R5i	0,75	260	54	400	240	1, 6
ACA 610-050/050-6								2xR5i	1,50	520	54	400 or 600	190	1
ACA 610-060/000-6	60	45	52	44	88	44	66	R6i	0,90	480	64	400	200	1
ACA 610-060/060-6								2xR6i	1,80	960	68	600	250	1
ACA 610-070/000-6	70	55	65	52	104	52	78	R6i	1,05	480	64	400	200	1
ACA 610-070/070-6								2xR6i	2,10	960	68	600	250	1
ACA 610-100/000-6,	100	75	88	65	130	65	98	R7i	1,50	480	64	400	200	1
ACA 610-100/100-6								2xR7i	3,00	960	68	600	250	1
ACA 610-120/000-6	120	90	105	88	176	88	132	R7i	1,80	480	64	400	200	1
ACA 610-120/120-6								2xR7i	3,60	960	68	600	250	1
ACA 610-0185-6	180	132	149	106	212	112	168	R8i	2,70	1550	61	600	250	2
ACA 610-0205-6	210	160	176	127	254	132	198	R8i	3,15	1550	61	600	250	2
ACA 610-0255-6	250	200	210	150	300	158	236	R8i	3,75	1550	61	600	250	2
ACA 610-315-6	310	250	264	179	358	198	297	R8i	4,65	1550	61	600	250	2
ACA 610-375-6	370	315	310	225	450	233	349	R9i	5,55	1550	61	600	270	2
ACA 610-0485-6	490	400	410	265	530	308	461	R9i	7,35	1550	61	600	270	2
ACA 610-600-6	600	500	502	340	680	377	565	R10i	9,00	3100	66	1000	450	2
ACA 610-0750-6	750	630	630	428	856	473	709	R11i	11,25	3100	66	1000	480	2
ACA 610-900-6	900	-	755	504	1008	566	849	R11i	13,50	3100	66	1000	480	2
ACA 610-1045-6	1040	-	874	641	1282	656	983	R12i	15,60	4650	69	1500	950	3
ACA 610-1385-6	1380	-	1156	755	1510	867	1301	R12i	20,70	4650	69	1500	950	3
ACA 610-1710-6	1710	-	1435	1007	2014	1076	1614	2xR11i	25,65	6200	69	2x1000	1200	3, 5
ACA 610-2125-6	2120	-	1777	1283	2566	1333	1999	2xR12i	31,80	9300	71	2x1500	1900	4
ACA 610-2545-6	2540	-	2129	1511	3022	1597	2395	2xR12i	38,10	9300	71	2x1500	1900	4
ACA 610-2800-6	2800	-	2344	1710	3420	1758	2637	4xR11i	42,00	12400	71	4x1000	2400	4
ACA 610-3350-6	3350	-	2809	2014	4028	2107	3160	4xR11i	50,25	12400	71	4x1000	2400	4
ACA 610-3880-6	3880	-	3251	2564	5128	2438	3657	4xR12i	58,20	18600	72	4x1500	3800	4
ACA 610-5140-6	5140	-	4300	3020	6040	3225	4838	4xR12i	77,10	18600	72	4x1500	3800	4

PDM code 00004863-C

Braking Section Tables

The following tables specify the ratings for the braking sections.

Abbreviations and Notes

The abbreviations and notes concerning the braking section tables are listed below.

Example: ACA 622-0640-3

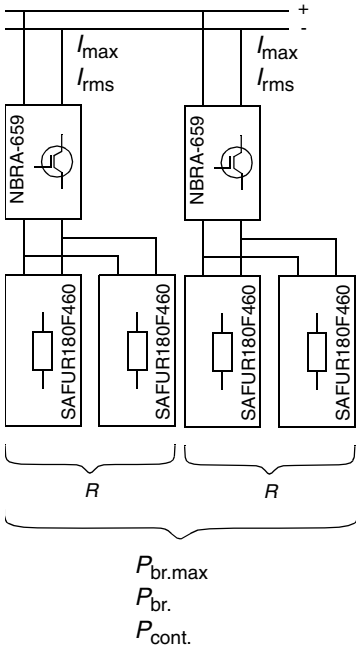

Braking Section	
$P_{br.max}$	Maximum braking power per section allowed momentarily
R	ACA 621 types: the minimum allowed resistance value for the braking resistor (recommended resistance) per chopper ACA 622 types: Resistance value for the used resistor per braking chopper (resistance of one (2 x SAFURxxxxxxx))
I_{max}	Peak braking current (d.c.) per chopper
$P_{cont.}$	Continuous braking power per section
Duty Cycle (10 s / 60 s)	
I_{rms}	Total rms d.c. current (per chopper) during a period of 10 seconds with braking power P_{br} .
$P_{br.}$	Short term braking power per section allowed for 10 seconds every 60 seconds
Duty Cycle (1 min / 5 min)	
I_{rms}	Total rms d.c. current (per chopper) during a period of 1 minute with braking power P_{br} .
$P_{br.}$	Short term braking power per section allowed for one minute every 5 minutes.
Braking current wave form	

Heat loss of the braking chopper is one percent of braking power.

The degree of protection for the SAFUR and NBRA-6xx is IP 00. The SAFUR resistors consist of several resistor elements. The resistance of one element is 8 ohm. The resistors are built in an metal frame.

The degree protection for the braking section cabinets is IP 21/22/42.

Ratings The table below shows the nominal ratings for the dynamic braking sections.

Section	Chopper	Resistor	$P_{br,max}$ (kW)	R (ohm)	I_{max} (A)	$P_{cont.}$ (kW)	Duty Cycle (1min/5min)		Duty Cycle (10s/60s)	
							$P_{br.}$ (kW)	I_{rms} (A)	$P_{br.}$ (kW)	I_{rms} (A)
Braking sections (380...415 V Range, $U_N = 400$ V)										
ACA 621-0210-3	NBRA658	*	230	1.7	384	70	230	355	230	355
ACA 621-0320-3	NBRA659	*	353	1.2	545	96	303	468	353	545
ACA 621-0640-3	2 x NBRA659	*	706	1.2	545	192	606	468	706	545
ACA 621-0960-3	3 x NBRA659	*	1058	1.2	545	288	909	468	1059	545
ACA 621-1280-3	4 x NBRA659	*	1411	1.2	545	384	1212	468	1412	545
ACA 621-1600-3	5 x NBRA659	*	1764	1.2	545	480	1515	468	1765	545
ACA 621-1920-3	6 x NBRA659	*	2117	1.2	545	576	1818	468	2118	545
ACA 622-0210-3	NBRA658	2 x SAFUR210F575	230	1.7	384	42	130	200	224	345
ACA 622-0320-3	NBRA659	2 x SAFUR180F460	353	1.2	545	54	167	257	287	444
ACA 622-0640-3	2 x NBRA659	2 x (2 x SAFUR180F460)	706	1.2	545	108	333	257	575	444
ACA 622-0960-3	3 x NBRA659	3 x (2 x SAFUR180F460)	1058	1.2	545	162	500	257	862	444
ACA 622-1280-3	4 x NBRA659	4 x (2 x SAFUR180F460)	1411	1.2	545	216	667	257	1150	444
ACA 622-1600-3	5 x NBRA659	5 x (2 x SAFUR180F460)	1764	1.2	545	270	833	257	1437	444
ACA 622-1920-3	6 x NBRA659	6 x (2 x SAFUR180F460)	2117	1.2	545	324	1000	257	1724	444
Braking sections (380...500 V Range, $U_N = 500$ V)										
ACA 621-0260-5	NBRA658	*	268	2.15	380	81	268	331	268	331
ACA 621-0400-5	NBRA659	*	403	1.43	571	109	317	391	403	498
ACA 621-0800-5	2 x NBRA659	*	806	1.43	571	218	634	391	806	498
ACA 621-1200-5	3 x NBRA659	*	1208	1.43	571	327	951	391	1209	498
ACA 621-1600-5	4 x NBRA659	*	1611	1.43	571	436	1268	391	1612	498
ACA 621-2000-5	5 x NBRA659	*	2014	1.43	571	545	1585	391	2015	498
ACA 621-2400-5	6 x NBRA659	*	2417	1.43	571	654	1902	391	2418	498
ACA 622-0260-5	NBRA658	2 x SAFUR125F500	268	2.00	408	36	111	137	192	237
ACA 622-0400-5	NBRA659	2 x SAFUR200F500	403	1.35	605	54	167	206	287	355
ACA 622-0800-5	2 x NBRA659	2 x (2 x SAFUR200F500)	806	1.35	605	108	333	206	575	355
ACA 622-1200-5	3 x NBRA659	3 x (2 x SAFUR200F500)	1208	1.35	605	162	500	206	862	355
ACA 622-1600-5	4 x NBRA659	4 x (2 x SAFUR200F500)	1611	1.35	605	216	667	206	1150	355
ACA 622-2000-5	5 x NBRA659	5 x (2 x SAFUR200F500)	2014	1.35	605	270	833	206	1437	355
ACA 622-2400-5	6 x NBRA659	6 x (2 x SAFUR200F500)	2417	1.35	605	324	1000	206	1724	355
Braking sections (525...690 V Range, $U_N = 690$ V)										
ACA 621-0400-6	NBRA669	*	404	2.72	414	119	298	267	404	361
ACA 621-0800-6	2 x NBRA669	*	807	2.72	414	238	596	267	808	361
ACA 621-1200-6	3 x NBRA669	*	1211	2.72	414	357	894	267	1212	361
ACA 621-1600-6	4 x NBRA669	*	1615	2.72	414	476	1192	267	1616	361
ACA 621-2000-6	5 x NBRA669	*	2019	2.72	414	595	1490	267	2020	361
ACA 621-2400-6	6 x NBRA669	*	2422	2.72	414	714	1788	267	2424	361
ACA 622-0400-6	NBRA669	2 x SAFUR200F500	404	1.35	835	54	167	149	287	257
ACA 622-0800-6	2 x NBRA669	2 x (2 x SAFUR200F500)	807	1.35	835	108	333	149	287	257
ACA 622-1200-6	3 x NBRA669	3 x (2 x SAFUR200F500)	1211	1.35	835	162	500	149	575	257
ACA 622-1600-6	4 x NBRA669	4 x (2 x SAFUR200F500)	1615	1.35	835	216	667	149	862	257
ACA 622-2000-6	5 x NBRA669	5 x (2 x SAFUR200F500)	2019	1.35	835	270	833	149	1150	257
ACA 622-2400-6	6 x NBRA669	6 x (2 x SAFUR200F500)	2422	1.35	835	324	2000	149	1724	257

PDM code 00017952-C

* The ACA 621 braking sections are not equipped with the braking resistors. They must be installed by the user.

Dimensions, Air Flow and Noise

The dimensions, air flows and noise levels for braking sections are given below. The depth of the cabinet is 600 mm. An extra 200 mm wide cabinet is added for top exit ACA 621 units.

Section	Height (mm)	Width (mm)	Weight (kg)	Noise (dB)	Air flow (m3/h)
Braking sections (380...415 V Range, $U_N = 400$ V)					
ACA 621-0210-3	2065	400	110	64	660
ACA 621-0320-3	2065	400	110	64	660
ACA 621-0640-3	2065	800	220	67	1320
ACA 621-0960-3	2065	1200	330	68	1980
ACA 621-1280-3	2065	1600	440	69	2640
ACA 621-1600-3	2065	2000	550	70	3300
ACA 621-1920-3	2065	2400	660	71	3960
ACA 622-0210-3	2078	1200	340	66	2500
ACA 622-0320-3	2078	1200	340	66	2500
ACA 622-0640-3	2078	2400	680	69	5000
ACA 622-0960-3	2078	3600	1020	70	7500
ACA 622-1280-3	2078	4800	1360	71	10000
ACA 622-1600-3	2078	6000	1700	72	12500
ACA 622-1920-3	2078	7200	2040	73	15000
Braking sections (380...500 V Range, $U_N = 500$ V)					
ACA 621-0260-5	2065	400	110	64	660
ACA 621-0400-5	2065	400	110	64	660
ACA 621-0800-5	2065	800	220	67	1320
ACA 621-1200-5	2065	1200	330	68	1980
ACA 621-1600-5	2065	1600	440	69	2640
ACA 621-2000-5	2065	2000	550	70	3300
ACA 621-2400-5	2065	2400	660	71	3960
ACA 622-0260-5	2078	1200	340	66	2500
ACA 622-0400-5	2078	1200	340	66	2500
ACA 622-0800-5	2078	2400	680	69	5000
ACA 622-1200-5	2078	3600	1020	70	7500
ACA 622-1600-5	2078	4800	1360	71	10000
ACA 622-2000-5	2078	6000	1700	72	12500
ACA 622-2400-5	2078	7200	2040	73	15000
Braking sections (525...690 V Range, $U_N = 690$ V)					
ACA 621-0400-6	2065	400	110	64	660
ACA 621-0800-6	2065	400	110	67	660
ACA 621-1200-6	2065	800	220	68	1320
ACA 621-1600-6	2065	1200	330	69	1980
ACA 621-2000-6	2065	1600	440	70	2640
ACA 621-2400-6	2065	2000	550	71	3300
ACA 622-0400-6	2078	1200	340	66	2500
ACA 622-0800-6	2078	1200	340	69	5000
ACA 622-1200-6	2078	2400	680	70	7500
ACA 622-1600-6	2078	3600	1020	71	10000
ACA 622-2000-6	2078	4800	1360	72	12500
ACA 622-2400-6	2078	6000	1700	73	15000

PDM code 00017952-C

Cabinet

The cabinet, degrees of protection and free space requirements of ACS 600 MultiDrive are listed below.

<i>ACx 600 Type</i>	<i>Enclosure</i>	<i>Degree of Protection</i>	<i>Space above mm</i>	<i>Space below mm</i>	<i>Space on left/right mm</i>	<i>Space in front/back mm</i>
ACS 600 MultiDrive	Cabinet	IP 21, IP 22, IP 42, IP 54 R 1)	500	0	0	200/100 2)

1) IP 21 = standard, R = air outlet duct

2) 200 between cabinets when installed back to back

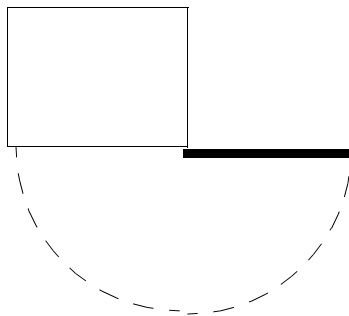

Common Cabinet Door Opening

IP 54 R Air Outlet Duct Connection

The dimensions of the duct adjoining to IP 54 R cabinet are below.

<i>Cabinet Width mm</i>	<i>Duct Ø mm</i>
400	250
600	310
800	310
1000	2x310
1500	3x310

Input Power Connection

Voltage (U_1):

380/400/415 VAC 3-phase $\pm 10\%$ for 400 VAC units
 380/400/415/440/460/480/500 VAC 3-phase $\pm 10\%$ for 500 VAC units
 525/550/575/600/660/690 VAC 3-phase $\pm 10\%$ for 690 VAC units
 525...830 VAC 3-phase $\pm 10\%$ for 830 VAC units

Short Circuit Capability (IEC 439-1): The rated short time withstand current of ACS 600 MultiDrive is given below.

Frame Type	$I_{cw} / 1\text{ s}$ (kA)	I_{pk} (kA)
B1, B2	18	38
B3	37	78
B4, B5	50	105
B4, B5 optional	65	137

Frequency: 48 to 63 Hz, maximum rate of change 17 %/s

Input Voltage Unbalance: $\pm 3\%$ (EN 60204-1)

Power Factor:

Diode and Thyristor Supply Units

($\cos \varphi_1$): 0.97 (fundamental at nominal load)

($\cos \varphi$): 0.93...0.95 (total)

IGBT Supply Units

$\cos \varphi_1 = 1.00$ (fundamental at nominal load)

$\lambda = I_1 / I_{rms} \cdot \cos \varphi_1 > 0.98$ (total) , where

λ is power factor,

I_1 is fundamental input current rms value,

I_{rms} is total input current rms value.

Motor Connection

Voltage (U_2): 0 to U_1 , 3-phase symmetrical.

Frequency: 0 to 300 Hz with 380 to 415 V,
 0 to 120 Hz with 525 to 690 V

Frequency Resolution: 0.01 Hz

Continuous Current: $1.0 \cdot I_{2N}$ (normal use)

Short Term Overload Capacity: see rating tables (valid when output frequency is > 10 Hz)

Field Weakening Point: 8 to 300 Hz

Switching Frequency: 2 kHz (average)

Maximum Recommended Motor Cable Length: For cables longer than 500 metres (cumulative length in case of parallel connected motors), an ABB representative must be consulted. With pulse encoder speed measurement maximum cable length is 300 m. With du/dt filters refer to *du/dt Installation Guide* (code: 58933368). For additional EMC requirements on cable length refer to section *CE Marking* below.

Cable Types: The tables below give the copper and aluminium cable types for different load currents (I_{Lmax}). A correction factor of $K = 0.70$ has been used (max. 9 cables laid on a cable ladder side by side, three ladders on top of each other, ambient temperature 30 °C (86 °F), EN 60204-1 and IEC 364-5-523)

COPPER CABLES WITH A CONCENTRIC COPPER SCREEN		
I_{Lmax} [A]	Cable Type	Diameter [mm]
13	3x1.5 + 1.5	13
18	3x2.5 + 2.5	14
24	3x4 + 4	16
30	3x6 + 6	18
42	3x10 + 10	21
56	3x16 + 16	23
71	3x25 + 16	24
88	3x35 + 16	26
107	3x50 + 25	29
137	3x70 + 35	32
167	3x95 + 50	38
193	3x120 + 70	41
223	3x150 + 70	44
255	3x185 + 95	50
274	2 x (3x70 + 35)	2 x 32
301	3x240 + 120	55
334	2 x (3x95 + 50)	2 x 38
386	2 x (3x120 + 70)	2 x 41
446	2 x (3x150 + 70)	2 x 44
510	2 x (3x185 + 95)	2 x 50
579	3 x (3x120 + 70)	3 x 41
602	2 x (3x240 + 120)	2 x 55
669	3 x (3x150 + 70)	3 x 44
765	3 x (3x185 + 95)	3 x 50
772	4 x (3x120 + 70)	4 x 41
892	4 x (3x150 + 70)	4 x 44
903	3 x (3x240 + 120)	3 x 55
1020	4 x (3x185 + 95)	4 x 50

ALUMINIUM CABLES WITH A CONCENTRIC COPPER SCREEN		
I_{Lmax} [A]	Cable Type	Diameter [mm]
69	3x35Al + 10Cu	26
83	3x50Al + 15Cu	29
107	3x70Al + 21Cu	32
130	3x95Al + 29Cu	38
151	3x120Al + 41Cu	41
174	3x150Al + 41Cu	44
199	3x185Al + 57Cu	49
214	2 x (3x70Al + 21Cu)	2 x 32
235	3x240Al + 72Cu	54
260	2 x (3x95Al + 29Cu)	2 x 38
302	2 x (3x120Al + 41Cu)	2 x 41
348	2 x (3x150Al + 41Cu)	2 x 44
398	2 x (3x185Al + 57Cu)	2 x 49
470	2 x (3x240Al + 72Cu)	2 x 54
522	3 x (3x150Al + 41Cu)	3 x 44
597	3 x (3x185Al + 57Cu)	3 x 49
696	4 x (3x150Al + 41Cu)	4 x 44
705	3 x (3x240Al + 72Cu)	3 x 54
796	4 x (3x185Al + 57Cu)	4 x 49
940	4 x (3x240Al + 72Cu)	4 x 54
995	5 x (3x185Al + 57Cu)	5 x 49
1175	5 x (3x240Al + 72Cu)	5 x 54

Bearings of over 90 kW Motors: Insulated bearing at non-driven end is recommended.

Efficiency and Cooling Method

Efficiency: Approximately 98 % at nominal power level and frequency. For units equipped with IGBT supply unit approximately 96 %.

Cooling Method: Internal fan, flow direction from the bottom to the top

Ambient Conditions

Environmental limits of the ACS 600 MultiDrive frequency converters are given below.

Condition	Operation installed for stationary use	Storage in the protective package	Transportation in the protective package
Installation Site Altitude	Nominal output power at 0 to 1000 m above sea level ¹⁾	-	-
Air Temperature	0 to +40 °C ²⁾ (IP 21/22/42) 0 to +35 °C ²⁾ (IP 54R)	-40 to +70 °C	-40 to +70 °C
Relative Humidity	5 to 95 %	Max. 95 %	Max. 95 %
	No condensation allowed. Maximum allowed relative humidity is 60 % in the presence of corrosive gases.		
Contamination Levels (IEC 721-3-3)	No conductive dust allowed.		
	Boards without coating: Chemical gases: Class 3C1 Solid particles: Class 3S2 Boards with coating: Chemical gases: Class 3C2 Solid particles: Class 3S2	Boards without coating: Chemical gases: Class 1C2 Solid particles: Class 1S3 Boards with coating: Chemical gases: Class 1C2 Solid particles: Class 1S3	Boards without coating: Chemical gases: Class 2C2 Solid particles: Class 2S2 Boards with coating: Chemical gases: Class 2C2 Solid particles: Class 2S2
Atmospheric Pressure	70 to 106 kPa	70 to 106 kPa	60 to 106 kPa
Vibration (IEC 68-2-6)	Max. 0.3 mm (2 to 9 Hz), max. 1 m/s ² (9 to 200 Hz) sinusoidal	Max. 1.5 mm (2 to 9 Hz), max. 5 m/s ² (9 to 200 Hz) sinusoidal	Max. 3.5 mm (2 to 9 Hz), max. 15 m/s ² (9 to 200 Hz) sinusoidal
Shock (IEC 68-2-29)	Not allowed	Max. 100 m/s ² , 11 ms	Max. 100 m/s ² , 11 ms
Free Fall	Not allowed	250 mm (weight under 100 kg) 100 mm (weight over 100 kg)	250 mm (weight under 100 kg) 100 mm (weight over 100 kg)

¹⁾ At sites over 1000 m above sea level, the maximum output current is derated as follows.

$$I_{max} = I_{N40C} \cdot (100 \% - 1 \% \cdot (h - 1000 \text{ m}) / (100 \text{ m}) + 1.5 \% \cdot (40 \text{ °C} - T_{amb}))$$

where

h altitude above sea level

*I*_{N40C} ACS 600 nominal current at 40 °C

*T*_{amb} maximum ambient temperature.

Note: *I*_{max} < *I*_{N40C} and *T*_{amb} < 40 °C. At 2000...4000 m optional “varistors” are needed.

²⁾ If the ambient temperature is higher than +40 °C (+35 °C), the output capacity of the ACx 600 decreases. The output current is calculated by multiplying the current given in the rating table by the derating factor.

Derating factor for degree of protection IP 21/22/42:

- Above +40 °C, the rated output current is decreased 1.5 % for every additional 1 °C (up to +50 °C).
- *Example 1.* If the ambient temperature is 50 °C the derating factor is

$$100\% - 1.5 \frac{\%}{^{\circ}\text{C}} \cdot 10^{\circ}\text{C} = 85\% \text{ or } 0.85.$$
 The output current is then $0.85 \cdot I_{2N}$ (or $I_{2\text{base}}$ or $I_{2\text{max}}$).

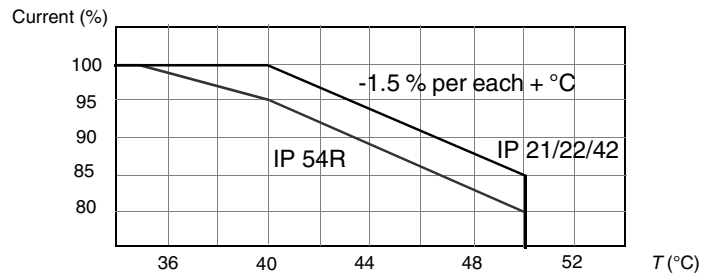

Derating Diagram: the effect of ambient temperature on the ACS 600 MultiDrive continuous load capacity.

Fuses

The ultrarapid fuses of the ACS 600 MultiDrive are given below. Equivalent fuses from other manufacturers can also be used. Only ultra rapid fuses guarantee proper protection for the rectifier semiconductors. U_N and I_N stand for the nominal voltage and the nominal current of the fuse.

AC Fuses Below are listed a.c. fuses (Bussmann) used in the supply section of ACS 600 MultiDrive frames B1, B2 and B3.

Thyristor Supply Section	Fuse					Diode Supply (6-pulse and 12-pulse) Section	Fuse				
	U_N (V)	I_N (A)	Pre-arching Integral (A^2s)	Type	Size		U_N (V)	I_N (A)	Pre-arching Integral (A^2s)	Type	Size
ACA 632-0015-31-xx ACA 632-0020-51-xx	660	50	115	170M1564	000						
ACA 632-0030-31-xx ACA 632-0035-51-xx	660	80	380	170M1566	000						
ACA 632-0040-31-xx ACA 632-0050-51-xx	660	125	1200	170M1568	000						
ACA 632-0070-31-xx ACA 632-0090-51-xx	660	160	2300	170M1569	000						
ACA 632-0140-31-xx ACA 632-0175-51-xx	660	315	4950	170M5806	2	ACA 631-0140-31-xx ACA 633-0280-31-xx ACA 631-0175-51-xx	660	315	4950	170M5806	2
ACA 632-0200-31-xx ACA 634-0200-31-xx ACA 632-0250-51-xx ACA 634-0250-51-xx	660	450	15500	170M5371	2SHT	ACA 631-0200-31-xx ACA 633-0400-31-xx ACA 631-0250-51-xx	690	500	21500	170M5810	2
ACA 632-0300-31-xx ACA 632-0375-51-xx	660	700	44500	170M6206	3SHT	ACA 631-0300-31-xx ACA 633-0600-31-xx ACA 631-0375-51-xx	690	800	69500	170M6812	3
ACA 632-0420-31-xx ACA 634-0420-31-xx ACA 636-0800-31-xx ACA 638-0800-31-xx ACA 639-0800-31-xx ACA 632-0525-51-xx ACA 636-1000-51-xx ACA 638-1000-51-xx ACA 639-1000-51-xx	660	900	100000	170M6207	3SHT	ACA 631-0420-31-xx ACA 633-0840-31-xx ACA 631-0525-51-xx	660	900	100000	170M6207	3SHT
ACA 632-0090-61-xx ACA 633-0180-61-xx ACA 632-0175-61-xx ACA 633-0350-61-xx	1250	200	3800	170M4700	1SHT	ACA 631-0090-61-xx	690	200	1200	170M5804	2
ACA 632-0250-61-xx	1250	315	13000	170M5403	2SHT	ACA 631-0175-61-xx	690	200	1200	170M5804	2
ACA 632-0375-61-xx	1250	400	23000	170M5404	2SHT	ACA 631-0250-61-xx	690	350	10000	170M3818	1*
ACA 632-0525-61-xx ACA 636-1000-61-xx	1250	630	83500	170M6205	3SHT	ACA 631-0375-61-xx	690	630	41000	170M5812	2
						ACA 631-0525-61-xx	690	800	69500	170M6812	3
						ACA 633-0180-61-xx	690	200	1200	170M5804	2
						ACA 633-0350-61-xx	690	200	1200	170M5804	2
						ACA 633-0500-61-xx	690	350	10000	170M3818	1*
						ACA 633-0750-61-xx	690	630	41000	170M5812	2
						ACA 633-1050-61-xx	690	800	69500	170M6812	3

PDM code 00010321-K

Branch Fuses Frame B4 to B5 diode and thyristor supply modules employ internal branch fuses instead of input or output fuses. The table lists the applicable Bussmann types.

Branch Fuses for Frame B4 and B5 Supply Modules					
Supply Module Type	U_N (V)	I_N (A)	Pre-arcing Integral (A²s)	Type	Size
ACN 654 0855 5 ACN 664 0855 5 ACN 684 0855 5	660	900	100000	170M6163	3/110
ACN 654 1405 5 ACN 664 1405 5 ACN 684 1405 5	660	1500	460000	170M6168	3/110
ACN 654 2120 5 ACN 664 2120 5 ACN 684 2120 5					
ACN 654 2600 5 ACN 664 2600 5 ACN 684 2600 5					
ACN 654 0855 6 ACN 664 0855 6 ACN 684 0855 6	1250	630	83500	170M6144	3/110
ACN 654 1405 6 ACN 664 1405 6 ACN 684 1405 6	1250	1100	575000	170M6149	3/110
ACN 654 2600 6 ACN 664 2600 6 ACN 684 2600 6					
ACN 654 3600 6 ACN 664 3600 6 ACN 684 3600 6	1110	1400	1250000	170M6151	3/110
ACN 654 1685 8 ACN 664 1685 8	1250	1100	575000	170M6149	3/110
ACN 654 3100 8 ACN 664 3100 8					
ACN 654 3520 8 ACN 664 3520 8	1110	1400	1250000	170M6151	3/110
ACN 654 4310 8 ACN 664 4310 8					

PDM code 00004021-B

Supply DC Fuses Below are listed Bussmann d.c. fuses used in the thyristor supply section of ACS MultiDrive frames B1, B2 and B3.

Thyristor Supply Section	Fuse				
	U_N (V)	I_N (A)	Pre-arcing Integral (A ² s)	Type	Size
400 V and 500 V Supply					
ACA 632-0015-31-xx ACA 632-0020-51-xx ACA 632-0030-31-xx ACA 632-0035-51-xx	1250	63		170M4722	1*
ACA 632-0040-31-xx ACA 632-0050-51-xx	1250	100		170M4724	1*
ACA 632-0070-31-xx ACA 632-0090-51-xx	1250	160	1900	170M4699	1*
ACA 632-0140-31-xx ACA 632-0175-51-xx	1250	315	13000	170M5140	2
ACA 632-0200-31-xx ACA 634-0200-31-xx ACA 632-0250-51-xx ACA 634-0250-51-xx	1250	400	23000	170M5142	2
ACA 632-0300-31-xx ACA 632-0375-51-xx	1250	630	115000	170M5146	2
ACA 632-0420-31-xx ACA 634-0420-31-xx ACA 636-0800-31-xx ACA 638-0800-31-xx ACA 639-0800-31-xx ACA 632-0525-51-xx ACA 636-1000-51-xx ACA 638-1000-51-xx ACA 639-1000-51-xx	1250	800	245000	170M5148	2
690 V Supply					
ACA 632-0090-61-xx ACA 633-0180-61-xx ACA 632-0175-61-xx ACA 633-0350-61-xx	1250	200	3800	170M4139	1
ACA 632-0250-61-xx	1250	315	13000	170M5140	2
ACA 632-0375-61-xx	1250	400	23000	170M5142	2
ACA 632-0525-61-xx ACA 636-1000-61-xx	1250	630	115000	170M5146	2

PDM code 000010321-K

Drive Unit DC Fuses Below are listed Bussmann fuses used in the inverters of ACS MultiDrive.

Drive Section Frame	Fuse					Drive Section Frame/Type	Fuse				
	U_N (V)	Size	I_N (A)	Pre-arcing Integral (A^2s)	Type		U_N (V)	Size	I_N (A)	Pre-arcing Integral (A^2s)	Type
415 V and 500 V Range						690 V Range					
R2i	660V	000	25	19	170M1561	R3i: ACA-610-0009-6 ACA-610-0011-6	1000V	00	25	29	170M2674
R3i	660V	000	50	115	170M1564	R3i: ACA-610-0016-6 ACA-610-0020-6	1000V	00	35	69	170M2676
R4i	660V	000	80	380	170M1566	R4i	1000V	00	63	380	170M2679
R5i	660V	000	160	2300	170M1569	R5i	1000V	00	80	815	170M2680
R6i	660V	000	200	4200	170M1570	R6i	1000V	00	125	3000	170M2682
R7i	660V	1*	350	10000	170M3818	R7i	1250V	1SHT	200	3800	170M4700
R8i R10i	660V	3	630	31000	170M6810	R8i: ACA-610-0185-6 ACA-610-0205-6	1250V	3SHT	315	9500	170M6301
R9i R11i 2xR11 4xR11i R12i 2xR12i	660V	3	1000	140000	170M6814	R8i: ACA-610-0255-6 ACA-610-0315-6 R10i	1250V	3SHT	400	19500	170M6303
						R9i R11i 4xR11i R12i 2xR12i 4xR12i	1250V	3SHT	630	83500	170M6205

PDM code 00008855-F

Braking Section DC Fuses

The d.c. fuses (Bussmann) for the braking sections are listed below.

Dynamic Braking Section	Fuse				
	U_N (V)	I_N (A)	Pre-arcing Integral (A ² s)	Type	Size
400 V Range					
ACA 621-0210-3	1000–1250	400	23000	170M 5142	2/110
ACA 621-0320-3...-1920-3	1000–1250	630	115000	170M 5146	2/110
ACA 622-0210-3	1000–1250	400	23000	170M 5142	2/110
ACA 622-0320-3...-1920-3	1000–1250	630	115000	170M 5146	2/110
500 V Range					
ACA 621-0260-5	1000–1250	400	23000	170M 5142	2/110
ACA 621-0400-5...-2400-3	1000–1250	630	115000	170M 5146	2/110
ACA 622-0260-5	1000–1250	400	23000	170M 5142	2/110
ACA 622-0400-5...-2400-5	1000–1250	630	115000	170M 5146	2/110
690 V Range					
ACA 621-0400-6...-2400-6	1000–1250	630	115000	170M 5146	2/110
ACA 622-0400-6...-2400-6	1000–1250	630	115000	170M 5146	2/110

PDM code 00025310-A

Power Cable Entries

Notes concerning the cable entry tables are below.

Tightening Torque

Tightening torques for screw connections (applicable to zinc and chrome platings and screw strength class 8.8) are presented below.

Screw	Torque (Nm) *	
	Soft aluminium	Alloyed aluminium and copper
M5	3.5	3.5
M6	6	9
M8	17	20
M10	35	40
M12	55	70
M16	130	180

* valid also for greased screws

Marking

Below is explained the way cable connections are marked in the following tables. The terminals accept cable lugs according to DIN 46234 for copper cables and DIN 46329 for aluminium cables.

4x(13x18)

Number of connection holes in terminal _____

Connection hole (max. screw) diameter or dimensions in mm _____

Note: Cable lugs can also be fastened using screws one size down from the hole size. Example: A cable lug with a hole diameter of 12.5 mm can be fastened with either a M12 or a M10 bolt.

Diode Supply Sections The connection holes for cable lugs and bus duct are presented below.

Type	Holes for cable lugs per phase	Number of cable entries at bottom (diameter 60 mm)	Bottom plate opening dimensions (mm)	Number of cable entries at top (diameter 60 mm)	Holes for bus duct connection
U_N = 400V (380V...415V)					
ACA 631-0140-3	2x14	3	310x240	3	-
ACA 631-0200-3	2x14	3	310x240	3	-
ACA 631-0300-3	4x14	6	502x280	6	-
ACA 631-0420-3	4x14	6	502x280	6	-
ACA 631-0680-3	4x(13x18)	12	502x280	12	4x(13x24)
ACA 631-1120-3	8x(13x18)	12	502x280	12	4x(13x24)
ACA 631-1700-3	12x(13x18)	18	502x280	18	4x(13x24)
ACA 631-2100-3	12x(13x18)	18	502x280	18	4x(13x24)
U_N = 500V (380V...500V)					
ACA 631-0175-5	2x14	3	310x240	3	-
ACA 631-0250-5	2x14	3	310x240	3	-
ACA 631-0375-5	4x14	6	502x280	6	-
ACA 631-0525-5	4x14	6	502x280	6	-
ACA 631-0850-5	4x(13x18)	12	502x280	12	4x(13x24)
ACA 631-1400-5	8x(13x18)	12	502x280	12	4x(13x24)
ACA 631-2120-5	12x(13x18)	18	502x280	18	4x(13x24)
ACA 631-2600-5	12x(13x18)	18	502x280	18	4x(13x24)
U_N = 690V (525V...690V)					
ACA 631-0090-6	2x14	3	310x240	3	-
ACA 631-0175-6	2x14	3	310x240	3	-
ACA 631-0250-6	2x14	3	310x240	3	-
ACA 631-0375-6	4x14	6	502x280	6	-
ACA 631-0525-6	4x14	6	502x280	6	-
ACA 631-0850-6	4x(13x18)	12	502x280	12	4x(13x24)
ACA 631-1400-6	8x(13x18)	12	502x280	12	4x(13x24)
ACA 631-2600-6	12x(13x18)	18	502x280	18	4x(13x24)
ACA 631-3600-6	12x(13x18)	18	502x280	18	4x(13x24)

Thyristor Supply Section: Terminal Block Connection The maximum cable size accepted by the terminal block of frame type B1 is given below.

Types: ACA 632-0015-3 ACA 632-0030-3 ACA 632-0040-3 ACA 632-0070-3 ACA 632-0020-5 ACA 632-0035-5 ACA 632-0050-5 ACA 632-0090-5	Frame Size B1	Cable Size		Tightening Torque	Cable entries at bottom (diameter 60 mm)	Bottom plate opening dimensions	Cable entries at top (diameter 60 mm)
		mm ²	AWG	Nm	pcs	mm	pcs
		70	2/0	8	3	310x240	3

Thyristor Supply Section: Busbar / Bus Duct Connection The connection holes for cable lugs and bus duct are presented below.

Type	Holes for cable lugs per phase	Number of cable entries at bottom (diameter 60 mm)	Bottom plate opening dimensions (mm)	Number of cable entries at top (diameter 60 mm)	Holes for bus duct connection
$U_N = 400V (380V...415V)$					
ACA 632-0140-3	2x14	3	310x240	3	-
ACA 632-0200-3	2x14	3	310x240	3	-
ACA 632-0300-3	4x14	6	502x280	6	-
ACA 632-0420-3	4x14	6	502x280	6	-
ACA 632-0680-3	4x(13x18)	12	502x280	12	4x(13x24)
ACA 632-1120-3	8x(13x18)	12	502x280	12	4x(13x24)
ACA 632-1700-3	12x(13x18)	18	502x280	18	4x(13x24)
ACA 632-2100-3	12x(13x18)	18	502x280	18	4x(13x24)
$U_N = 500V (380V...500V)$					
ACA 632-0175-5	2x14	3	310x240	3	-
ACA 632-0250-5	2x14	3	310x240	3	-
ACA 632-0375-5	4x14	6	502x280	6	-
ACA 632-0525-5	4x14	6	502x280	6	-
ACA 632-0850-5	4x(13x18)	12	502x280	12	4x(13x24)
ACA 632-1400-5	8x(13x18)	12	502x280	12	4x(13x24)
ACA 632-2120-5	12x(13x18)	18	502x280	18	4x(13x24)
ACA 632-2600-5	12x(13x18)	18	502x280	18	4x(13x24)
$U_N = 690V (525V...690V)$					
ACA 632-0090-6	2x14	3	310x240	3	-
ACA 632-0175-6	2x14	3	310x240	3	-
ACA 632-0250-6	2x14	3	310x240	3	-
ACA 632-0375-6	4x14	6	502x280	6	-
ACA 632-0525-6	4x14	6	502x280	6	-
ACA 632-0850-6	4x(13x18)	12	502x280	12	4x(13x24)
ACA 632-1400-6	8x(13x18)	12	502x280	12	4x(13x24)
ACA 632-2600-6	12x(13x18)	18	502x280	18	4x(13x24)
ACA 632-3600-6	12x(13x18)	18	502x280	18	4x(13x24)
$U_N = 830V (525V...830V)$					
ACA 632-1680-8	4x(13x18)	12	502x280	12	4x(13x24)
ACA 632-3100-8	12x(13x18)	18	502x280	18	4x(13x24)
ACA 632-3520-8	12x(13x18)	18	502x280	18	4x(13x24)
ACA 632-4310-8	12x(13x18)	18	502x280	18	4x(13x24)

Drive Sections: Terminal Block Connection The maximum cable sizes accepted by the terminal block for motor and brake cable connection (terminals U2, V2, W2, PE, UDC+, UDC-) of frame types R2i to R5i are given below.

Frame	Cable Size			Tightening Torque	Cable entries at bottom (diameter 60 mm)	Bottom plate opening dimensions	Cable entries at top (diameter 60 mm)
	Solid	Stranded					
	mm ²	mm ²	AWG	Nm	pcs	mm	pcs
R2i	10	6	8	1.5...1.8	3	110x235	3
R3i	16	10	6	1.5...1.8	3	110x235	3
R4i	25	16	4	1.5...1.8	3	110x235	3
R5i	35	25	2	4.0...4.5	3	110x235	3

Drive Sections: Busbar Connection The connection holes for motor and brake cable lugs (terminals U2, V2, W2, PE, UDC+, UDC-) of the drive sections are presented below.

Type	Holes for cable lugs per phase	Number of cable entries at bottom (diameter 60 mm)	Bottom plate opening dimensions (mm)	Number of cable entries at top (diameter 60 mm)
380V, 400V, 415V				
ACA 610-0060-3	1x(13x18)	3	110x235	3
ACA 610-0070-3	1x(13x18)	3	110x235	3
ACA 610-0100-3	1x(13x18)	3	110x235	3
ACA 610-0120-3	1x(13x18)	3	110x235	3
ACA 610-0185-3	4x(13x18)	6	270x511	6
ACA 610-0225-3	4x(13x18)	6	270x511	6
ACA 610-0265-3	4x(13x18)	6	270x511	6
ACA 610-0335-3	4x(13x18)	6	270x511	6
ACA 610-0405-3	4x(13x18)	6	270x511	6
ACA 610-0500-3	6x(13x18)	6	270x911	6
ACA 610-0630-3	6x(13x18)	6	270x911	6
ACA 610-0760-3	6x(13x18)	6	270x911	6
ACA 610-0935-3	8x(13x18)	12	195x501	12
ACA 610-1125-3	8x(13x18)	12	195x501	12
ACA 610-1440-3	16x(13x18)	18	270x711	18
ACA 610-1775-3	16x(13x18)	18	270x711	18
ACA 610-2145-3	16x(13x18)	18	270x711	18
ACA 610-2340-3	16x(13x18)	18	270x711	18
ACA 610-2820-3	16x(13x18)	18	270x711	18
440V, 460V, 500V				
ACA 610-0070-5	1x(13x18)	3	110x235	3
ACA 610-0100-5	1x(13x18)	3	110x235	3
ACA 610-0120-5	1x(13x18)	3	110x235	3
ACA 610-0140-5	1x(13x18)	3	110x235	3
ACA 610-0205-5	4x(13x18)	6	270x511	6
ACA 610-0255-5	4x(13x18)	6	270x511	6
ACA 610-0325-5	4x(13x18)	6	270x511	6
ACA 610-0395-5	4x(13x18)	6	270x511	6

Type	Holes for cable lugs per phase	Number of cable entries at bottom (diameter 60 mm)	Bottom plate opening dimensions (mm)	Number of cable entries at top (diameter 60 mm)
ACA 610-0495-5	4x(13x18)	6	270x511	6
ACA 610-0610-5	6x(13x18)	6	270x911	6
ACA 610-0770-5	6x(13x18)	6	270x911	6
ACA 610-0935-5	6x(13x18)	6	270x911	6
ACA 610-1095-5	8x(13x18)	12	195x501	12
ACA 610-1385-5	8x(13x18)	12	195x501	12
ACA 610-1760-5	16x(13x18)	18	270x711	18
ACA 610-2165-5	16x(13x18)	18	270x711	18
ACA 610-2625-5	16x(13x18)	18	270x711	18
ACA 610-2850-5	16x(13x18)	18	270x711	18
ACA 610-3450-5	16x(13x18)	18	270x711	18
575V, 660V, 690V				
ACA 610-0060-6	1x(13x18)	3	110x235	3
ACA 610-0070-6	1x(13x18)	3	110x235	3
ACA 610-0100-6	1x(13x18)	3	110x235	3
ACA 610-0120-6	1x(13x18)	3	110x235	3
ACA 610-0185-6	4x(13x18)	6	270x511	6
ACA 610-0205-6	4x(13x18)	6	270x511	6
ACA 610-0255-6	4x(13x18)	6	270x511	6
ACA 610-0315-6	4x(13x18)	6	270x511	6
ACA 610-0375-6	4x(13x18)	6	270x511	6
ACA 610-0485-6	6x(13x18)	6	270x911	6
ACA 610-0600-6	6x(13x18)	6	270x911	6
ACA 610-0750-6	6x(13x18)	6	270x911	6
ACA 610-0900-6	6x(13x18)	6	270x911	6
ACA 610-1045-6	8x(13x18)	12	195x501	12
ACA 610-1385-6	8x(13x18)	12	195x501	12
ACA 610-1710-6	8x(13x18)	12	195x501	12
ACA 610-2125-6	16x(13x18)	18	270x711	18
ACA 610-2545-6	16x(13x18)	18	270x711	18
ACA 610-2800-6	16x(13x18)	18	270x711	18
ACA 610-3350-6	16x(13x18)	18	270x711	18
ACA 610-3880-6	32x(13x18)	18	270x911	18
ACA 610-5140-6	32x(13x18)	18	270x911	18

NIOC Board Specifications

Data of the external control connection board NIOC-01 of the ACS 600 product family are given below. NIOC-01 board is included in the drive section of the ACS 600 MultiDrive. For external control connections of the supply section, refer to *Diode/Thyristor/IGBT Supply Sections User’s Manual*. For external control connections of the control section, refer to Common Drive Control Manuals.

	ACS/ACC/ACP 600, ACS 600 MultiDrive NIOC-01 Board
<p>Analogue Inputs</p> <p>The advantage of the differential analogue input is that the earth potential of the device or transmitter sending an analogue signal can differ up to ± 15 V from the earth potential of the ACx 600 chassis without disturbing the signal. Differential input also efficiently attenuates common mode disturbances coupled to control cables.</p>	<p>ACS 600, ACS 600 MultiDrive: Two Programmable Differential Current Inputs: 0 (4) to 20 mA, $R_{in} = 100 \Omega$</p> <p>ACC 600: Two Differential Current Inputs: 0 to 20 mA, $R_{in} = 100 \Omega$</p> <p>ACP 600: One Programmable Differential Current Input: 0 to 20 mA, $R_{in} = 100 \Omega$</p> <p>ACS/ACP 600, ACS 600 MultiDrive: One Programmable Differential Voltage Input: ACS 600: 0 (2) to 10 V, $R_{in} > 200 \text{ k}\Omega$; ACP 600: 0 to 10 V, $R_{in} > 200 \text{ k}\Omega$</p> <p>ACC 600: One Differential Voltage Input: 0 to 10 V, $R_{in} > 200 \text{ k}\Omega$</p> <p>Common Mode Voltage: ± 15 VDC, max.</p> <p>Common Mode Rejection Ratio: ≥ 60 dB at 50 Hz</p> <p>Resolution: 0.1 % (10 bit)</p> <p>Inaccuracy: ± 0.5 % (Full Scale Range) at 25 °C. Temperature Coefficient: ± 100 ppm/°C, max.</p> <p>Input Updating Time: 12 ms (ACS 600), 44 ms (ACC 600), 1 ms (ACP 600), 10 ms (ACS 600 MultiDrive)</p>
<p>Constant Voltage Output</p>	<p>Voltage: 10 VDC ± 0.5 % (Full Scale Range) at 25 °C. Temperature Coefficient: ± 100 ppm/°C, max.</p> <p>Maximum Load: 10 mA</p> <p>Applicable Potentiometer: 1 kΩ to 10 kΩ</p>
<p>Auxiliary Power Output</p>	<p>Voltage: 24 VDC ± 10 %, Short circuit proof</p> <p>Maximum Current: 250 mA or 130 mA with NLMD-01 option</p>
<p>Analogue Outputs</p>	<p>ACS/ACC 600, ACS 600 MultiDrive: Two Programmable Current Outputs: 0 (4) to 20 mA, $R_L \leq 700 \Omega$</p> <p>ACP 600: One Programmable Current Output: 0 to 20 mA, $R_L \leq 700 \Omega$</p> <p>Resolution: 0.1 % (10 bit)</p> <p>Inaccuracy: ± 1 % (Full Scale Range) at 25 °C. Temperature Coefficient: ± 200 ppm/°C, max.</p> <p>Output Updating Time: 24 or 100 ms (ACS 600), 44 ms (ACC 600), 8 ms (ACP 600), 10 ms (ACS 600 MultiDrive)</p>

	ACS/ACC/ACP 600, ACS 600 MultiDrive NIOC-01 Board
Digital Inputs	<p>ACS/ACP 600, ACS 600 MultiDrive: Six Programmable Digital Inputs (Common Ground): 24 VDC, -15 to +20 %</p> <p>ACC 600: Six Digital Inputs (Common Ground): 24 VDC, -15 to +20 %</p> <p>Logical Thresholds: < 8 VDC $\hat{=}$ "0", > 12 VDC $\hat{=}$ "1"</p> <p>Input Current: DI1 to DI 5: 10 mA, DI6: 5 mA</p> <p>Filtering Time Constant: 1 ms</p> <p>Thermistor Input: 5 mA, < 1.5 kΩ $\hat{=}$ "1" (normal temperature), > 4 kΩ $\hat{=}$ "0" (high temperature), Open Circuit $\hat{=}$ "0" (high temperature)</p> <p>Internal Supply For Digital Inputs (+24 VDC): Short circuit proof, group isolated</p> <p>Isolation Test Voltage: 500 VAC, 1 minute</p> <p>Input Updating Time: 12 ms (ACS 600), 44 ms (ACC 600), 4 ms (ACP 600), 10 ms (ACS 600 MultiDrive)</p> <p>An external 24 VDC supply can be used instead of the internal supply.</p>
Digital Outputs	-
Relay Outputs	<p>Three Programmable Relay Outputs</p> <p>Switching Capacity: 8 A at 24 VDC or 250 VAC, 0.4 A at 120 VDC</p> <p>Maximum Continuous Current: 2 A rms</p> <p>Contact Material: Silver Cadmium Oxide (AgCdO)</p> <p>Isolation Test Voltage: 4 kVAC, 1 minute</p> <p>Output Updating Time: 100 ms (ACS 600), 44 ms (ACC 600), 8 ms (ACP 600), 10 ms (ACS 600 MultiDrive)</p>
DDCS Fibre Optic Link	Protocol: DDCS (ABB Distributed Drives Communication System)
Encoder Input	

Application Programs

Various application programs are available for the ACS 600 frequency converters. Not all selections are available for all types. One application program at a time can be loaded in the memory of the frequency converter.

ACS 600 Application Programs
Standard
CraneDrive
MotionControl
System

Protection Features Application program dependent features of the ACx 600 are listed below. ● available as standard, ○ optional. Not all selections are available for all types. For more information refer to the appropriate application program *Firmware Manual*.

Preprogrammed Faults	Standard PFC, M/F	Crane	Motion Control	System	Programmable Fault Functions	Standard PFC, M/F	Crane	MotionControl	System	Programm. Supervision Functions	Standard PFC, M/F	Crane	Motion Control	System
ACx 600 temperature	●	●	●	●	Analogue input below minimum value	●				Speed	2		2	2
Overcurrent	●	●	●	●	Loss of Control Panel	●	●		●	Motor current	●			●
Short circuit	●	●	●	●	External fault	●	●	●	●	Motor torque	2		●	2
DC overvoltage	●	●	●	●	Motor overtemperature	●	●	●	●	Motor speed	●			●
Supply phase	●	●	●	●	Thermistor/Pt 100	●	●	●	●	Reference 1	●			
DC undervoltage	●	●	●	●	Motor stalled	●		●	●	Reference 2	●			
Overfrequency	●	●		●	Motor underload	●		●	●	Actual value 1	●			
Loss of Control Panel			●		Loss of motor phase	●	●	●	●	Position error			●	
Internal fault	●	●	●	●	Earth fault	●	●	●	●	Synchron error			●	
Internal fault on the I/O control board	●	●	●	●	Speed measurement			●		Position threshold			4	
Ambient temperature	●	●	●	●	Motor overspeed		●			Joystick		●		
User Macro	●	●	●	●	Torque		●			Brake long falling time		●		
Braking chopper (in fieldbus mode)		●			Torque proving		●							
Inverter overload		●			Master/Follower communication	●	●							
No motor data	●	●		●	Brake		●							
ID Run fail	●	●		●	Communication test			●						
Motor fan control and diagnostics				●	Following error			●						
					Position limits	○	○	●	○					
					Communication error									
					Encoder interface module	○	○	●	○					
					Overspeed			●						

Preprogrammed Warnings: ACS 600 temperature, Motor Identification Run, Drive Identification Number change, User Macro, Target position (ACP).

Programmable Automatic Reset Functions (ACS 600 Standard Application Program only): after overcurrent, overvoltage, undervoltage and analogue input below minimum value

Information Functions: ACx 600 control firmware package version, ACx 600 application program version, ACx 600 test date.

Applicable Standards

The ACS 600 MultiDrive complies with the following standards:

- EN 60204-1: 1992 + Corr. 1993 (IEC 204-1). Safety of machinery. Electrical equipment of machines. Part 1: General requirements.
- EN 60529: 1991 (IEC 529), IEC 664-1: 1992. Degrees of protection provided by enclosures (IP code).
- EN 50178: 1986. Electronic equipment for use in power installations.
- EN 61800-3 (1996): EMC product standard including specific test methods.

Materials

Enclosure	Coating Thickness	Color
hot-dip zinc coated steel sheet 1.0 to 2.5 mm with polyester thermosetting powder coating in outer surface visible parts	60 µm	RAL 7035 light beige semigloss
Flat Busbars		
aluminium (standard), copper (optional), tin plated copper (optional)		
Package		
wood or plywood (seaworthy package). Plastic covering of the package: PE-LD, bands PP or steel.		

Transportation

Length: max. 4 metres, weight max. 2400 kg

Position: upright

Max. crate dimensions:

length shipping length + 100 mm

depth shipping split depth + 150 mm

height height + 80 mm

Max. seaworthy dimensions:

length shipping length + 200 mm

depth shipping split depth + 185 mm

height 2200 mm

Disposal

ACx 600 contains raw materials that should be recycled to preserve energy and natural resources. The packing materials of ACx 600 units and options are environmentally compatible and recyclable. All metal parts can be recycled. The plastic parts can either be recycled or burned under controlled circumstances, according to local regulations. If recycling is not feasible, all parts excluding electrolytic capacitors can be landfilled. The DC capacitors of the unit contain electrolyte which is classified as hazardous waste. They must be removed and handled according to local regulations.

For further information on environmental aspects, please contact your local ABB distributor.

CE Marking

A CE mark is attached to ACS 600 MultiDrive frequency converters (380...690 V ranges) to verify that the unit fulfils the European Low Voltage and EMC Directives (Directive 73/23/EEC, as amended by 93/68/EEC and Directive 89/336/EEC, as amended by 93/68/EEC).

Compliance with the EMC Directive

EMC stands for **E**lectromagnetic **C**ompatibility. It is the ability of electrical/electronic equipment to operate without problems within an electromagnetic environment. Likewise, the equipment must not disturb or interfere with any other product or system within its locality.

The EMC Directive defines the requirements for immunity and emissions of electrical equipment used in the European Economic Area. The EMC product standard EN 61800-3 covers the requirements stated for frequency converters.

The ACS 600 MultiDrive frequency converters comply with the EMC Directive in industrial low-voltage network, public low-voltage network (restricted distribution) and IT networks (unearthed mains) with the following provisions.

Industrial Low-Voltage Network

1. It is ensured that no excessive emission is propagated to neighbouring low-voltage networks. In some cases, the natural suppression in transformers and cables is sufficient. If in doubt, the ACS 600 MultiDrive can be equipped with EMC filtering (refer to Table A-1 below) or the supply transformer with static screening between the primary and secondary windings can be used.
2. The ACS 600 MultiDrive is installed according to the instructions given in the *Hardware Manual* (EN code 63700118).
3. The motor and control cables are selected as specified in the *Hardware Manual* (EN code 63700118).

Note: It is recommended to equip the ACS 600 MultiDrive with the EMC filtering if there is equipment sensitive to conducted emission connected to the same supply transformer as the ACS 600 MultiDrive.

**Unearthed Mains
(IT Network)**

1. It is ensured that no excessive emission is propagated to neighbouring low-voltage networks. In some cases, the natural suppression in transformers and cables is sufficient. If in doubt, the supply transformer with static screening between the primary and secondary windings can be used.
2. The ACS 600 MultiDrive is installed according to the instructions given in the *Hardware Manual* (EN code 63700118).
3. The motor and control cables used are selected as specified in the *Hardware Manual* (EN code 63700118).

Note: The ACS 600 MultiDrive must not be equipped with EMC filtering when installed to IT networks. The mains becomes connected to earth potential through the EMC filter capacitors. In IT networks this may cause danger or damage the unit.

Machinery Directive

ACS 600 MultiDrive frequency converters comply with the European Union Machinery Directive (98/37/EC) requirements for an equipment intended to be incorporated into machinery.

CSA Marking

The CSA marking is often required in North America. CSA marked ACS 600 MultiDrive frequency converters are available on request up to 600 V.

The ACS 600 MultiDrive is suitable for use in a circuit capable of delivering not more than 65 kA rms symmetrical amperes at 600 V maximum.

The ACS 600 MultiDrive provides overload protection in accordance with the National Electrical Code (US). See *ACS 600 Firmware Manual* for setting. Default setting is off, must be activated at start-up.

ACS 600 drives are to be used in a heated indoor controlled environment. See subsection [Ambient Conditions](#) for specific limits.

“C-tick”  Marking

A “C-tick” mark is attached to ACS 600 MultiDrive frequency converters to verify that the unit follows the provisions of

- Radiocommunications (Electromagnetic Compatibility) Standard 1998
- Radiocommunications (Compliance Labelling - Incidental Emissions) Notice 1998
- AS/NZS 2064: 1997. Limits and methods of measurement of electronic disturbance characteristics of industrial, scientific and medical (ISM) radiofrequency equipment.
- Radiocommunication Regulations of New Zealand (1993).

**Compliance with AS/
NZS 2064**

The above rules define the essential requirements for emissions of electrical equipment used in Australia and New Zealand. The standard AS/NZS 2064 (Limits and methods of measurement of electronic disturbance characteristics of industrial, scientific and medical radiofrequency equipment, 1997) covers the detailed requirements for three-phase frequency converters.

The ACS 600 MultiDrive frequency converters comply with AS/NZS 2064 for class A equipment (suitable for use in all establishments other than domestic and those directly connected to a low-voltage network which supplies buildings used for domestic purposes). The compliance is valid with the following provisions:

1. The ACS 600 MultiDrive is equipped with EMC filtering (refer to Table A-1).
2. The ACS 600 MultiDrive is installed according to the instructions given in the *Hardware Manual* (EN code 63700118).
3. The motor and control cables used are selected as specified in the *Hardware Manual* (EN code 63700118).
4. Maximum cable length is 100 metres.

Note: The ACS 600 MultiDrive must not be equipped with EMC filtering (refer to Table A-1) when installed to IT networks. The mains becomes connected to earth potential through the EMC filter capacitors. In IT networks this may cause danger or damage the unit.

Equipment Warranty and Liability

General: ABB warrants the Equipment supplied by ABB against defects in material and workmanship for a period of twelve (12) months after installation or twenty-four (24) months from date of shipment from factory, whichever first occurs.

Should any failure to conform with the applicable warranties appear during the specified periods under normal and proper use and provided the Equipment has been properly stored, installed, operated and maintained, and if given prompt notice by Purchaser, ABB shall correct such nonconformity, at its option; by (1) repair or replacement of the nonconforming equipment or parts thereof. Repairs or replacements pursuant to warranty shall not renew or extend the applicable original equipment warranty period, provided however, that any such repairs or replacement of equipment or parts thereof shall be warranted for the time remaining of the original warranty period or 30 days, whichever is longer.

ABB shall not be responsible for providing working access to the defect, including disassembly and reassembly of equipment or for providing transportation to and from repair or factory facility, all of which shall be at Purchaser's risk and expense.

These warranties shall not apply to any Equipment or parts thereof which (1) have been improperly repaired or altered; (2) have been subjected to misuse, negligence or accident; (3) have been used in a manner contrary to ABB's instructions; (4) are comprised of materials provided or designed stipulated by Purchaser; or (5) are used equipment.

The foregoing warranties are exclusive and in lieu of all other warranties of quality and performance, written, oral or implied, and all other warranties including any implied warranties of merchantability or fitness for a particular purpose are hereby disclaimed by ABB and all equipment manufacturers.

Correction of nonconformities in the manner and for the period of time provided above shall be the Purchaser's exclusive remedy and shall constitute fulfilment of all liabilities of ABB and any Equipment manufacturer (including any liability for direct, indirect, special, incidental or consequential damages) whether in warranty, contract, negligence, tort, strict liability, or otherwise with respect to any nonconformance of or defect or deficiency in the equipment supplied or services furnished hereunder.

Limitation of Liability

IN NO EVENT SHALL ABB, ITS SUPPLIERS OR SUBCONTRACTORS BE LIABLE FOR SPECIAL, INDIRECT, INCIDENTAL OR CONSEQUENTIAL DAMAGES, WHETHER IN CONTRACT, WARRANTY, TORT, NEGLIGENCE, STRICT LIABILITY OR OTHERWISE, including, but not limited to loss of profits or revenue, loss of use of the Equipment or any associated equipment, cost of capital, cost of substitute equipment, facilities or services, downtime costs, delays, or claims of customers of the Purchaser or other third parties for such or other damages. ABB's liability on any claim whether in contract, warranty, negligence, tort, strict liability, or otherwise for any loss or damage arising out of, connected with, or resulting from the contract or the performance or breach thereof, or from the design, manufacture, sale, delivery, resale, repair, replacement, installation, technical direction of installation, inspection, operation or use of any equipment covered by or in connection therewith, shall in no case exceed the purchase price of the Equipment or part thereof or services which give rise to the Claim.

All clauses of action against ABB arising out of or relating to the contract or the performance or breach hereof shall expire unless brought within one year of the time of accrual thereof.

In no event, regardless of cause, shall ABB assume responsibility for or be liable for penalties or penalty clauses of any description or for indemnification of customer or others for costs, damages, or expenses each arising out of or related to the goods or services of the order.

Your local distributor or ABB office may hold different guarantee details, which are specified in the sales terms, conditions, or guarantee terms. These terms are available on request.

If you have any questions concerning your ABB frequency converter, please contact the local distributor or ABB office. The technical data, information and specifications are valid at the time of printing. The manufacturer reserves the right to modifications without prior notice.

Marine Applications – Technical Data

Ratings

The supply, braking and drive section tables in [ACS 600 MultiDrive – Technical Data](#) apply to marine applications with the following notes.

Note Concerning Height: The height in the tables does not include vibration dampers (18 mm at bottom and 72 mm on top of the cabinet). The additional height due to the dampers is 90 mm.

Note Concerning Depth: The basic depth of the cabinet without door devices is 600 mm. Additional 50 mm is required at the back and in front of the cabinet for the vibration dampers. Maximum depth (including flash barriers and hand grips on the door) is 758 mm.

Note: not all types are available for marine applications

Cabinet

The cabinet, degrees of protection and free space requirements for marine applications are listed below.

ACx 600 Type	Enclosure	Degree of Protection	Space above mm	Space below mm	Space on left/right mm	Space in front/back mm
ACS 600 MarineDrive	Cabinet	IP 22, IP 42, IP 54 R ¹⁾	500	0	0	200/100 ²⁾

¹⁾ R = air outlet duct

²⁾ 200 between rear plates of the cabinets when installed back to back

Ambient Conditions

The ambient conditions given in [ACS 600 MultiDrive – Technical Data](#) apply to marine applications with the following exception:

Condition	Operation installed for stationary use	Storage in the protective package	Transportation in the protective package
Vibration (IEC 68-2-6)	Amplitude ± 1,0 mm (5 to 13,2 Hz) Acceleration 7m/s ² (13,2 to 100 Hz)	Amplitude ± 1,0 mm (5 to 13,2 Hz) Acceleration 7m/s ² (13,2 to 100 Hz)	Amplitude ± 1,0 mm (5 to 13,2 Hz) Acceleration 7m/s ² (13,2 to 100 Hz)

Applicable Standards

The ACS 600 MultiDrive for marine applications complies with the following standards:

- IEC 60092-302: 1997 Electrical installations in ships, low voltage switchgear and controlgear assemblies.
- EN 60204-1: 1992 + Corr. 1993 (IEC 204-1). Safety of machinery. Electrical equipment of machines. Part 1: General requirements.
- EN 60529: 1991 (IEC 529), IEC 664-1: 1992. Degrees of protection provided by enclosures (IP code).
- EN 50178: 1986. Electronic equipment for use in power installations.
- EN 61800-3 (1996): EMC product standard including specific test methods.

Materials

Enclosure	Coating Thickness	Colour
Hot-dip zinc coated steel sheet 1.0 to 2,5 mm with polyester thermosetting powder coating (only in visible parts)	60 µm	RAL 7035 light beige semigloss
Flat Busbars		
Tin plated copper		
Package		
Wood or plywood (seaworthy package). Plastic covering of the package: PE-LD, bands PP or steel.		

Other Technical Data

See chapter [ACS 600 MultiDrive – Technical Data](#). The data for ACS 600 MultiDrive applies also to marine applications if specific data is not included in this chapter.



ABB Industry Oy
Drives
P.O. Box 184
FIN-00381 HELSINKI
FINLAND
Telephone +358 10 22 2000
Telefax +358 10 22 22681
Internet <http://www.abb.com/automation>

3AFY 63982229 R0125 REV D
EFFECTIVE: 1.12.2000 EN