

# ACS350

[efesotomasyon.com](http://efesotomasyon.com)

---

Supplement  
ACS350 Drives with IP66/67 / UL Type 4X Enclosure  
(0.37...7.5 kW, 0.5...10 HP)

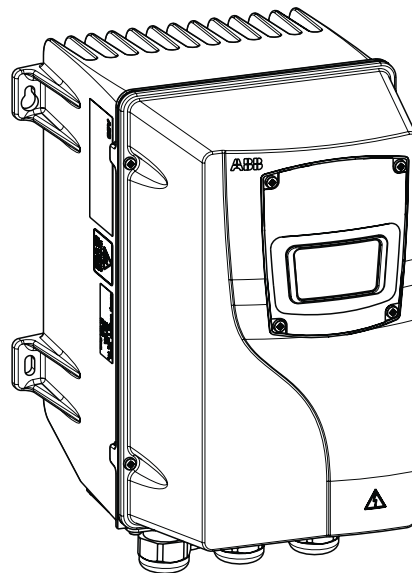

**ABB**

## DRIVE MANUALS

---

ACS350 Drives (0.37...22 kW, 0.5...30 HP) User's Manual  
3AFE68462401 (EN)

## OPTION MANUALS (delivered with optional equipment)

---

FCAN-01 CANopen Adapter Module User's Manual  
3AFE68615500 (EN)

FDNA-01 DeviceNet Adapter Module User's Manual  
3AFE68573360 (EN)

FMBA-01 Modbus Adapter Module User's Manual  
3AFE68586704 (EN)

FPBA-01 PROFIBUS DP Adapter Module User's Manual  
3AFE68573271 (EN)

FRSA-00 RS-485 Adapter Board User's Manual  
3AFE68640300 (EN)

MFDT-01 FlashDrop User's Manual  
3AFE68591074 (EN)

## MAINTENANCE MANUALS

---

Guide for Capacitor Reforming in ACS50/150/350/550  
3AFE68735190 (EN)

ACS350 Drives with  
IP66/67 / UL Type 4X Enclosure  
0.37...7.5 kW  
0.5...10 HP

## **Supplement**

[efesotomasyon.com](http://efesotomasyon.com)

---

3AUA0000042326 REV B  
EN  
EFFECTIVE: 31.3.2009



# Safety

---

## What this chapter contains

The chapter contains the safety instructions which you must follow when installing, operating and servicing the drive. If ignored, physical injury or death may follow, or damage may occur to the drive, motor or driven equipment. Read the safety instructions before you work on the drive.

## Use of warning symbols

There are two types of safety warnings throughout this manual:



**Danger; electricity** warns of high voltage which can cause physical injury and/or damage to the equipment.



**General danger** warns about conditions, other than those caused by electricity, which can result in physical injury and/or damage to the equipment.

## Installation and maintenance work

These warnings are intended for all who work on the drive, motor cable or motor.



**WARNING!** Ignoring the following instructions can cause physical injury or death, or damage to the equipment.

### Only qualified electricians are allowed to install and maintain the drive!

- Never work on the drive, motor cable or motor when input power is applied. After disconnecting the input power, always wait for 5 minutes to let the intermediate circuit capacitors discharge before you start working on the drive, motor or motor cable.

Always ensure by measuring with a multimeter (impedance at least 1 Mohm) that:

1. There is no voltage between the drive input phases U1, V1 and W1 and the ground.
  2. There is no voltage between terminals BRK+ and BRK- and the ground.
- Do not work on the control cables when power is applied to the drive or to the external control circuits. Externally supplied control circuits may carry dangerous voltage even when the input power of the drive is switched off.
  - Do not make any insulation or voltage withstand tests on the drive.
  - If a drive whose EMC filter is not disconnected is installed on an IT system [an ungrounded power system or a high resistance-grounded (over 30 ohms) power system], the system will be connected to earth potential through the EMC filter capacitors of the drive. This may cause danger or damage the drive.
  - If a drive whose EMC filter is not disconnected is installed on a corner grounded TN system, the drive will be damaged.

### Note:

- Even when the motor is stopped, dangerous voltage is present at the power circuit terminals U1, V1, W1 and U2, V2, W2 and BRK+ and BRK-.



**WARNING!** Ignoring the following instructions can cause physical injury or death, or damage to the equipment.



- Do not install anything inside the drive that is not explicitly instructed in this manual or the ACS350 User's Manual.
- The drive is not field repairable. Never attempt to repair a malfunctioning drive; contact your local ABB representative or Authorized Service Center for replacement.
- Make sure that dust from drilling does not enter the drive during the installation. Electrically conductive dust inside the drive may cause damage or lead to malfunction.
- Ensure sufficient cooling.

## Operation and start-up



These warnings are intended for all who plan the operation, start up or operate the drive.



**WARNING!** Ignoring the following instructions can cause physical injury or death, or damage to the equipment.

- Before adjusting the drive and putting it into service, make sure that the motor and all driven equipment are suitable for operation throughout the speed range provided by the drive. The drive can be adjusted to operate the motor at speeds above and below the speed provided by connecting the motor directly to the power line.
- Do not activate automatic fault reset functions if dangerous situations can occur. When activated, these functions will reset the drive and resume operation after a fault.
- Do not control the motor with an AC contactor or disconnecting device (disconnecting means); use instead the control panel start and stop keys  and  or external commands (I/O or fieldbus). The maximum allowed number of charging cycles of the DC capacitors (i.e. power-ups by applying power) is two per minute and the maximum total number of chargings is 15 000.

**Note:**

- If an external source for start command is selected and it is ON, the drive will start immediately after an input voltage break or fault reset unless the drive is configured for 3-wire (a pulse) start/stop.
- When the control location is not set to local (LOC not shown on the display), the stop key on the control panel will not stop the drive. To stop the drive using the control panel, press the LOC/REM key  and then the stop key .



# Table of contents

---

ACS350 drive manuals .....	2
----------------------------	---

## **Safety**

What this chapter contains .....	5
Use of warning symbols .....	5
Installation and maintenance work .....	6
Operation and start-up .....	7

## **Table of contents**

### **About the manual**

What this chapter contains .....	13
Scope .....	13
Compatibility .....	13
Intended audience .....	13
Categorization according to the frame size .....	14
Product and service inquiries .....	14
Product training .....	14
Providing feedback on ABB Drives manuals .....	14
Installation and commissioning flowchart .....	15

### **Hardware description**

What this chapter contains .....	17
Overview .....	17
Overview: Connections .....	19
Type code .....	19

### **Mechanical installation**

What this chapter contains .....	21
Safety .....	21
Unpacking the drive .....	22
Delivery check .....	23
Before installation .....	23
Requirements for the installation site .....	23
Mounting the drive and hygienic installation .....	24
Attaching the optional fieldbus module .....	24
Installing the pressure compensation valve (optional, +C169) .....	24
Installing the cable glands (optional, +H376) .....	25
Installing conduit fittings .....	26
Cable gland kit part list .....	26
Tightening torques .....	26

**Electrical installation**

What this chapter contains .....	27
Checking the insulation of the assembly .....	27
Connecting the power cables .....	28
Connection diagram .....	28
Procedure .....	29
Connecting the control cables .....	30

**Installation checklist**

Checklist .....	31
-----------------	----

**Maintenance and hardware diagnostics**

What this chapter contains .....	33
Safety .....	33
Maintenance intervals .....	33
Cleaning the drive .....	34
Basic cleaning .....	34
Thorough cleaning .....	34
Internal fan .....	34
Internal fan replacement .....	35

**Technical data**

What this chapter contains .....	37
Ratings .....	38
Current and power .....	38
Symbols .....	38
Sizing .....	39
Derating .....	39
Cooling air flow requirements .....	39
Power cable sizes and fuses .....	40
Cable temperature ratings and sizes .....	40
I/O cables .....	41
Power cables: terminal sizes, maximum cable diameters and tightening torques .....	41
Dimensions, weights and noise .....	41
Input power connection .....	41
Motor connection .....	41
Control connections .....	41
Brake resistor connection .....	41
Efficiency .....	41
Cooling .....	41
Degrees of protection .....	42
Ambient conditions .....	42
Materials .....	42
CE marking .....	43
Compliance with the EMC Directive .....	43
Compliance with EN 61800-3 (2004) .....	43

NSF mark .....	43
Applicable standards .....	43
RoHS marking .....	44
UL marking .....	44
IEC/EN 61800-3 (2004) Definitions .....	44
Compliance with the IEC/EN 61800-3 (2004) .....	45
Product protection in the USA .....	46
Brake resistors .....	46

### ***Dimensions***

Frame size R1, IP66/67 UL Type 4X .....	48
Frame size R3, IP66/67 UL Type 4X .....	49
R1 gland plate (EU) .....	50
R1 conduit fitting plate (US) .....	51
R3 gland plate (EU) .....	52
R3 conduit fitting plate (US) .....	53



# About the manual

---

## What this chapter contains

The chapter describes the intended audience and compatibility of this manual. It also contains a flowchart of steps for checking the delivery and installing and commissioning the drive. The flowchart refers to chapters/sections in this manual and the ACS350 User's Manual.

## Scope

This supplement is intended to be used with the *ACS350 Drives (0.37...22 kW, 0.5...30 HP) User's Manual (3AFE68462401)*. The supplement covers differences between the standard ACS350 and the ACS350 with IP66/67 / UL Type 4X enclosure (option +B063).

The following chapters can only be found in the user's manual:

- Planning electrical installation
- Start-up, control with I/O and ID Run
- Control panels
- Application macros
- Program features
- Actual signals and parameters
- Fieldbus control with embedded fieldbus
- Fieldbus control with fieldbus adapter
- Fault tracing

## Compatibility

The manual is compatible with the ACS350 drive firmware version 2.57c or later. See parameter 3301 FIRMWARE in the ACS350 User's Manual.

## Intended audience

This manual is intended for persons who plan the installation, install, commission, use and service the drive. Read the manual before working on the drive. The reader is expected to know the fundamentals of electricity, wiring, electrical components and electrical schematic symbols.

This manual is written for readers worldwide. Both SI and imperial units are shown. Special US instructions for installations in the United States are given.

## **Categorization according to the frame size**

The ACS350 with IP66/67 / UL Type 4X enclosure is manufactured in frame sizes R1 and R3. Some instructions, technical data and dimensional drawings which only concern certain frame sizes are marked with the symbol of the frame size (R1 or R3). To identify the frame size of your drive, see the rating table on page 38 in chapter *Technical data*.

## **Product and service inquiries**

Address any inquiries about the product to your local ABB representative, quoting the type code and serial number of the unit in question. A listing of ABB sales, support and service contacts can be found by navigating to [www.abb.com/drives](http://www.abb.com/drives) and selecting *Sales, Support and Service network*.

## **Product training**

For information on ABB product training, navigate to [www.abb.com/drives](http://www.abb.com/drives) and select *Training courses*.

## **Providing feedback on ABB Drives manuals**

Your comments on our manuals are welcome. Go to [www.abb.com/drives](http://www.abb.com/drives), then select successively *Document Library – Manuals feedback form*.

## Installation and commissioning flowchart

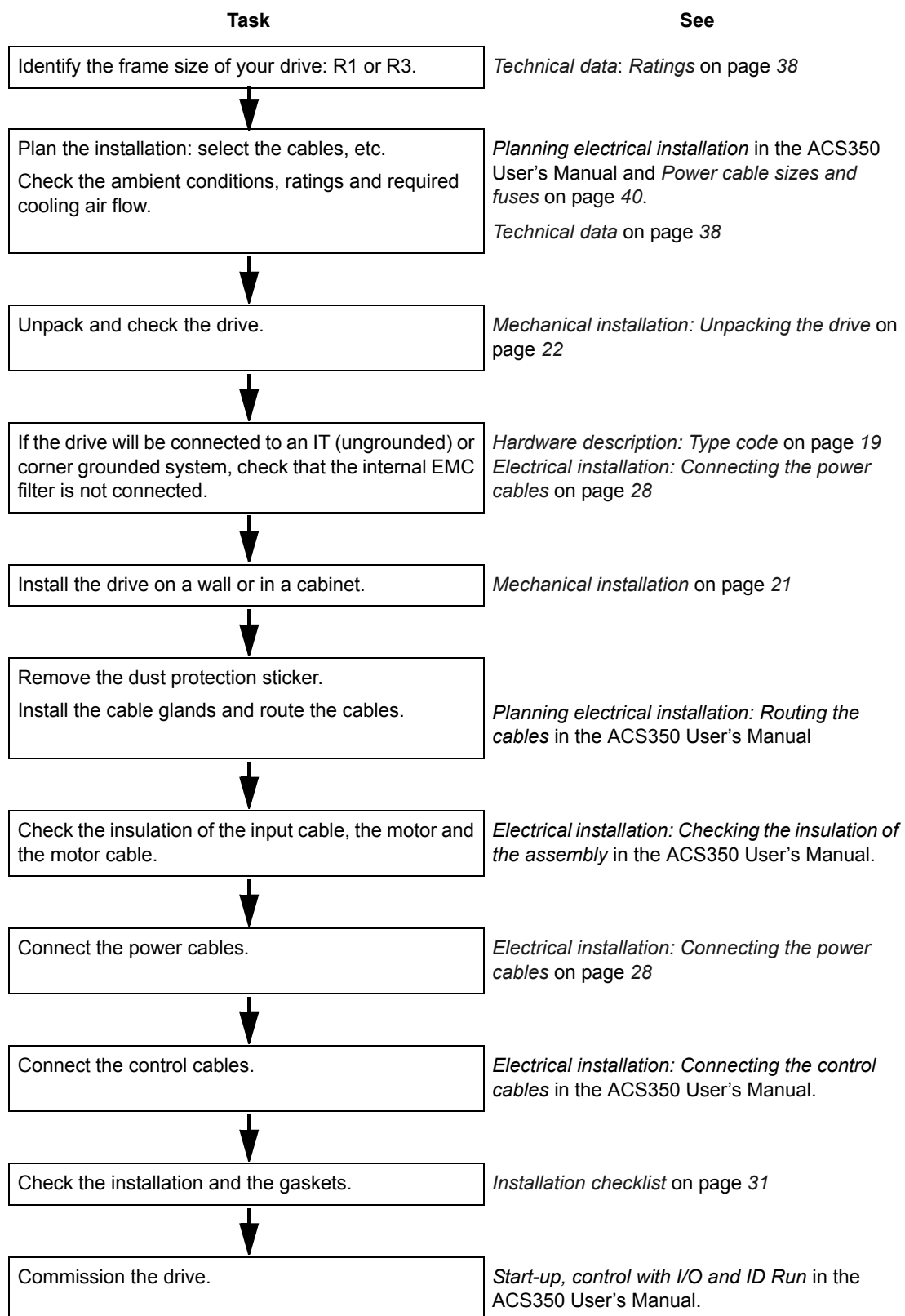



# Hardware description

## What this chapter contains

The chapter describes the construction and type code information in short.

## Overview

The ACS350 with IP66/67 / UL Type 4X enclosure is a wall mountable drive for controlling AC motors. The construction of frame sizes R1 and R3 varies to some extent.

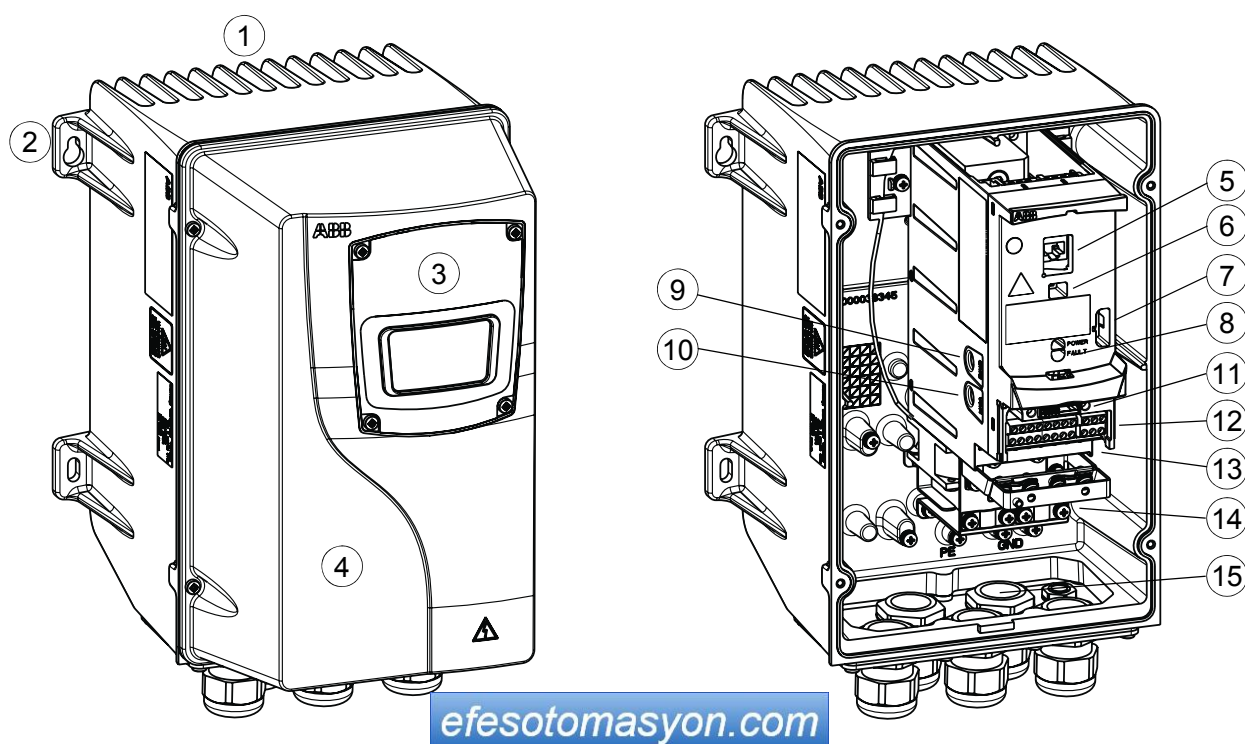

Covers on (R1)

Covers off (R1)

1	Cooling element
2	Mounting holes
3	Control Panel
4	Front cover

5	Panel connection
6	Option connection
7	FlashDrop connection
8	Power OK and Fault LEDs
9	EMC filter grounding screw (EMC).
10	Varistor grounding screw (VAR)
11	Fieldbus adapter (serial communication module) connection
12	I/O connections
13	Input power connection (U1, V1, W1), brake resistor connection (BRK+, BRK-) and motor connection (U2, V2, W2)
14	Clamping plate
15	Cable glands

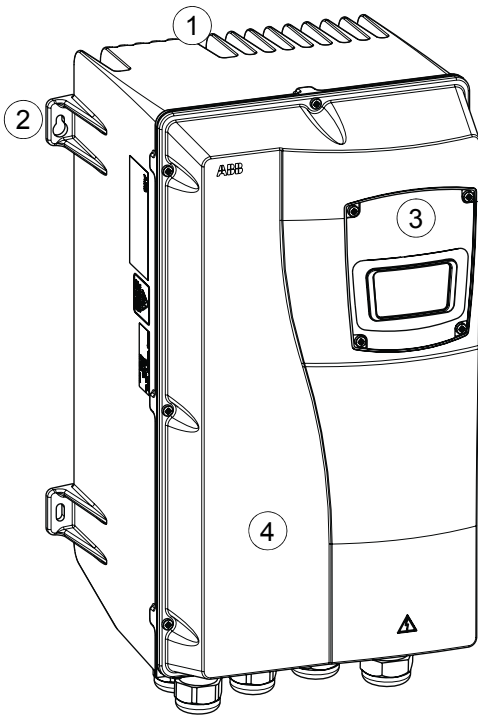

Covers on (R3)

1	Cooling element
2	Mounting holes
3	Control Panel
4	Front cover

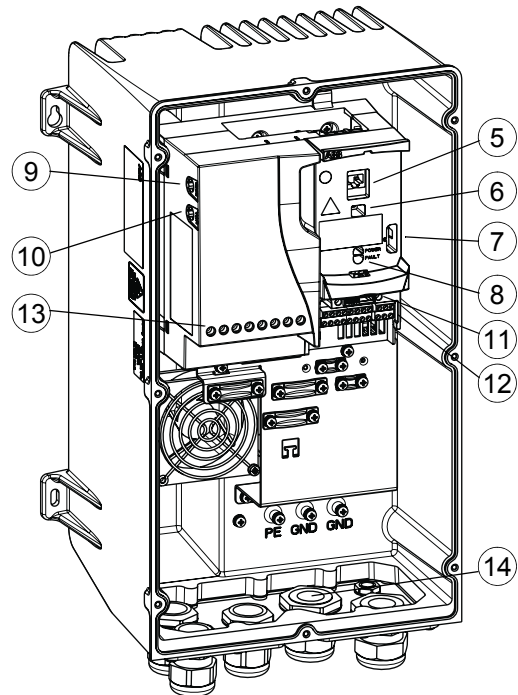

Covers off (R3)

5	Panel connection
6	Option connection
7	FlashDrop connection
8	Power OK and Fault LEDs
9	EMC filter grounding screw (EMC).
10	Varistor grounding screw (VAR)
11	Fieldbus adapter (serial communication module) connection
12	I/O connections
13	Input power connection (U1, V1, W1), brake resistor connection (BRK+, BRK-) and motor connection (U2, V2, W2)
14	Cable glands

## Overview: Connections

See the ACS350 User's Manual.

## Type code

The type code contains information on the specifications and configuration of the drive. You find the type code on the type designation label attached to the drive. The first digits from the left express the basic configuration, for example ACS350-03E-08A8-4+B063. The optional selections are given after that, separated by + signs, for example +K451. The explanations of the type code selections are described below.

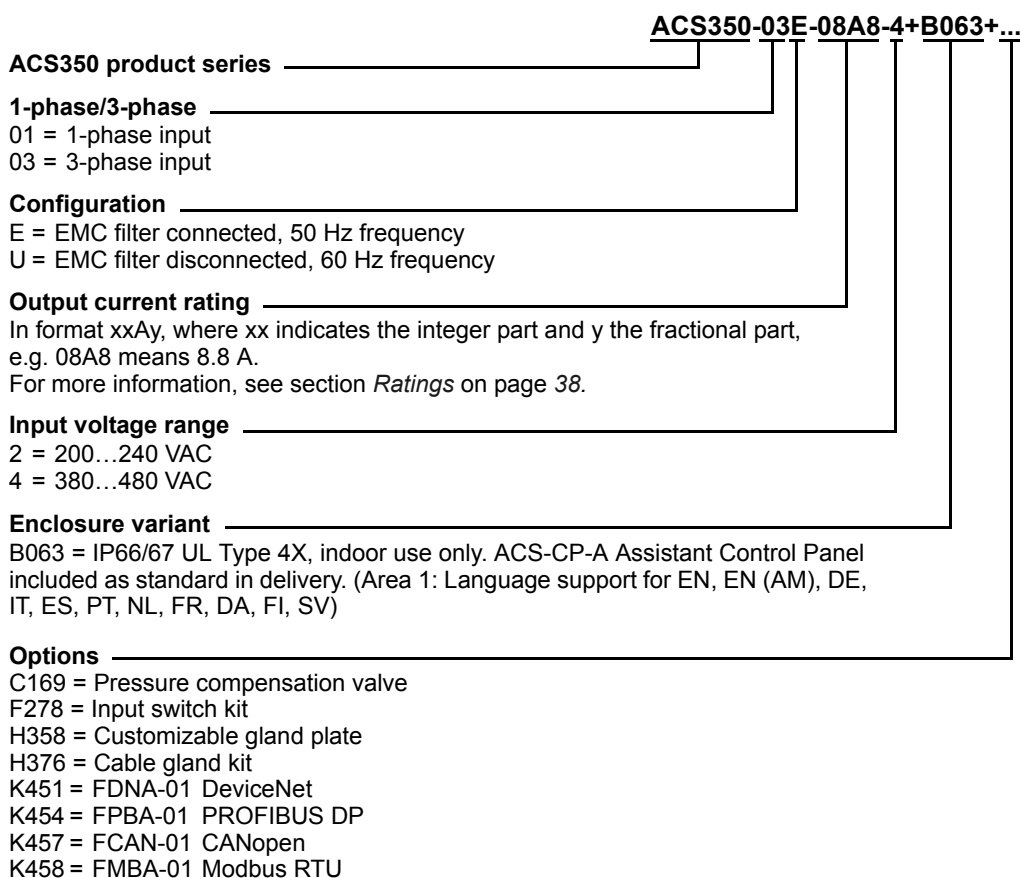



# Mechanical installation

---

## What this chapter contains

The chapter describes the mechanical installation procedure of the drive.

## Safety



---

**WARNING!** Do not install anything inside the drive that is not explicitly instructed in this manual or the ACS350 User's Manual.

---



---

**WARNING!** Do not install the drive outdoors. The drive is intended for indoor use only.

---



---

**WARNING!** Choose the cables according to section *Power cable sizes and fuses* on page 40. Using inappropriate cables shortens cable insulation lifetime.

---

## Unpacking the drive

The package contains the following items:

- (1) ACS350 with IP66/67 UL Type 4X enclosure and Assistant Control Panel (frame size R3 shown in the figure)
- (2) user's manual and (3) IP66/67 UL Type 4X supplement
- mounting template

The package may contain some of the following optional items:

- (4) pressure compensation valve (option +C169)
- (5) Cable Gland Kit (option +H376)
- (6) Input Switch (option +F278)
- other options (such as fieldbus options, instructions for the options).

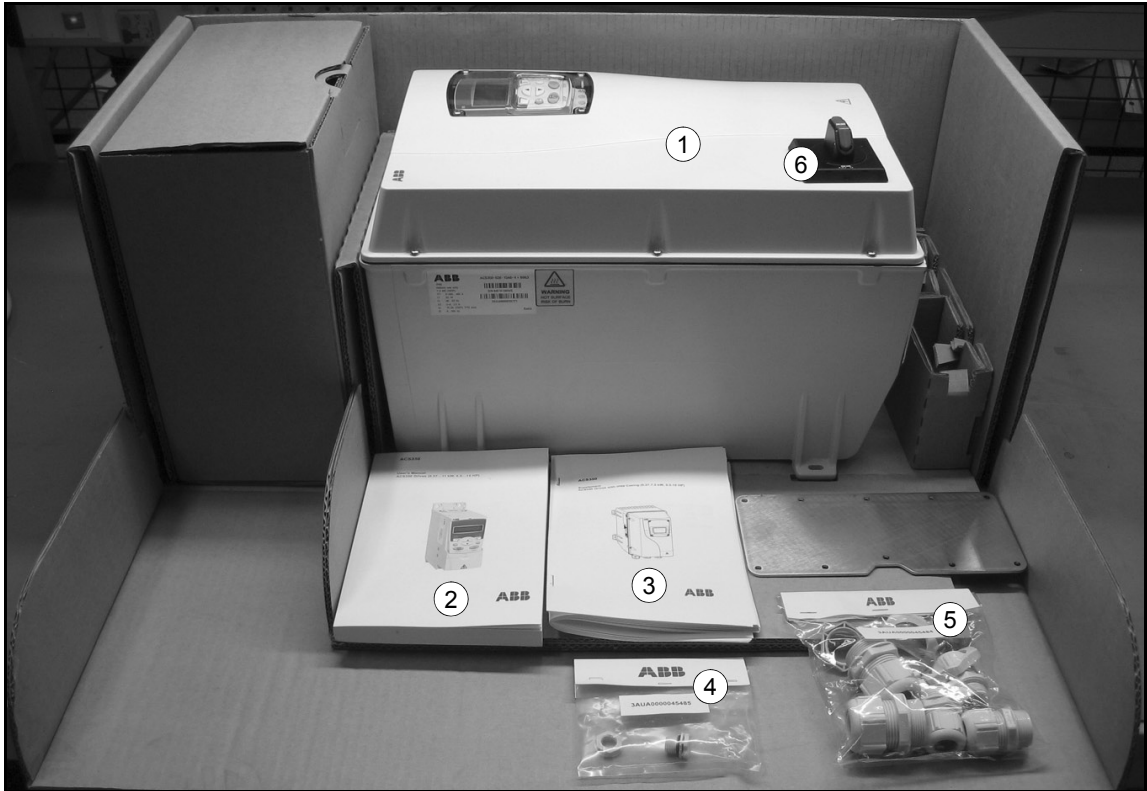

[efesotomasyon.com](http://efesotomasyon.com)

## Delivery check

Check that there are no signs of damage. Notify the shipper immediately if damaged components are found.

Before attempting installation and operation, check the information on the type designation label of the drive to verify that the drive is of the correct type. The type designation label is attached to the left side of the drive. An example label and explanation of the label contents are shown below.

	1	Type code, see section <i>Type code</i> on page 19
	2	Degree of protection (IP and UL/NEMA)
	3	Nominal ratings, see section <i>Ratings</i> on page 38.
	4	Serial number of format YWWRXXXXWS, where Y: 5...9, A, ... for 2005...2009, 2010, ... WW: 01, 02, 03, ... for week 1, week 2, week 3, ... R: A, B, C, ... for product revision number XXXX: Integer starting every week from 0001
	5	ABB MRP code of the drive
	6	CE marking, C-Tick mark, NSF mark and RoHS mark (the label of your drive shows the valid markings)

*Type designation label*

## Before installation

See the ACS350 User's Manual.

### Requirements for the installation site

See chapter *Technical data* for the allowed operation conditions of the drive.

#### Wall

The wall should be as close to vertical and even as possible, of non-flammable material and strong enough to carry the weight of the drive.

#### Floor

The floor/material below the installation should be non-flammable.

#### Free space around the drive

The required free space for cooling above and below the drive is 75 mm (3 in.).

For hygienic installation, ensure that there is enough free space around the drive to clean it. There should be free space in front of the drive, above and below it, on either side of it, and also between its back and the wall it is mounted onto. To make the clearance from the wall large enough, use spacers and fastening lugs.

## Mounting the drive and hygienic installation

Attach the drive to the wall using back mounting.

---

**Note:** To fulfill the requirements for hygienic installation, leave enough free space around the drive. See *Free space around the drive* for more information.

---

**Note:** Make sure that dust from drilling does not enter the drive during the installation.

---

1. Mark the locations for the holes (4 pcs) using e.g. the mounting template. The locations of the holes are also shown in the drawings in chapter *Dimensions*.
2. Fix the screws or bolts to the marked locations.
3. Position the drive onto the screws on the wall.
4. Tighten the screws in the wall securely.

## Attaching the optional fieldbus module

See the ACS350 User's Manual.

## Installing the pressure compensation valve (optional, +C169)

1. Remove the M12 plug from the gland plate.
2. Tighten the pressure compensation valve with its back nut to a torque of 0.8 N·m.

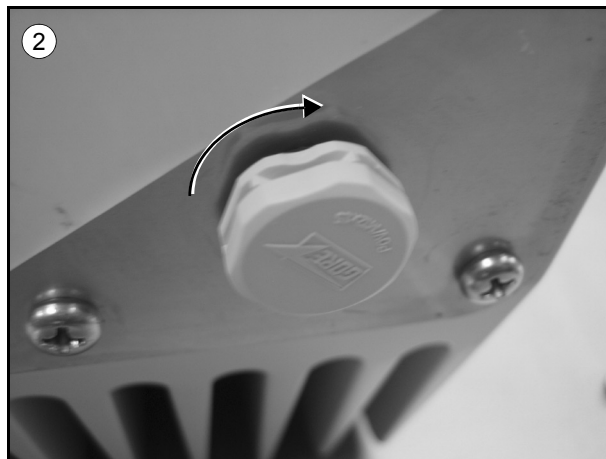
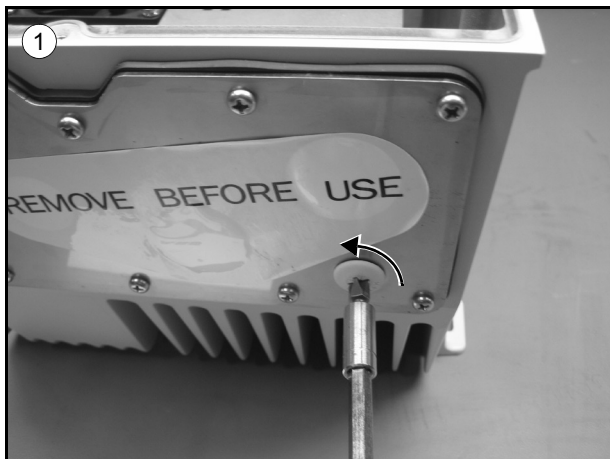

## Installing the cable glands (optional, +H376)

**Note:** The lead-throughs are only meant for sealing the enclosure. Do not use them for grounding.

1. Remove the sticker labeled REMOVE BEFORE USE.
2. Tighten the cable glands that you want to use with their back nuts. The tightening torque depends on the cable gland size. See *Tightening torques* on page 26.
3. Lead the cable through the gland and tighten until the gasket of the lead-through is tightly around the cable. The cable diameter depends on the cable gland size:
  - M12: 3.5...7.0 mm
  - M25: 9.0...17.0 mm
  - M32: 11.0...21.0 mm

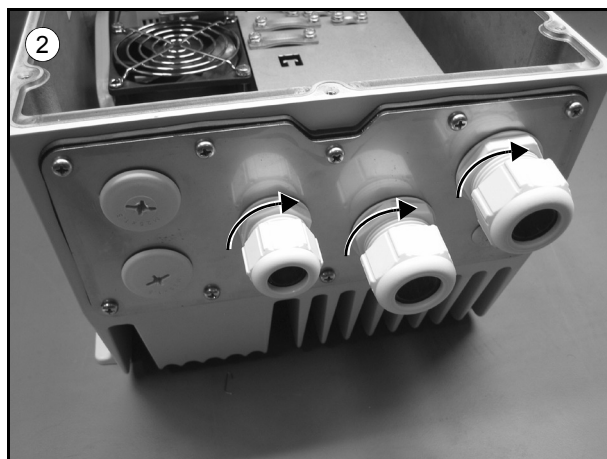

## Installing conduit fittings

Install conduit fittings according to manufacturer recommendations for hole sizes 1/2" and 3/4".

The 12.5 mm diameter hole is for the optional pressure compensation valve (+C169). Do not use it for any other purpose.

## Cable gland kit part list

R1 Cable Gland Kit, 3AUA0000045483	
Pcs	Part
5	M25 cable gland
3	M25 back nut
1	M12 cable gland

R3 Cable Gland Kit, 3AUA0000045484	
Pcs	Part
2	M32 cable gland
2	M32 back nut
3	M25 cable gland
1	M25 back nut
1	M12 cable gland

## Tightening torques

**Note:** Tightening torques for US-specific conduit fittings are not listed below. Consult the manufacturer for the tightening torques.

Tightening torques	
Part	N·m
Panel cover screws	2.0
Cover screws	2.0
Cable gland screws	2.0
EMC and VAR screws	0.5
Fan screws	1.2

Tightening torques, optional parts	
Part	N·m
Cable gland, size M12	3.0
Cable gland, size M25	8.0
Cable gland, size M32	10.0
Pressure compensation valve	0.8
Cable hole plugs	1.5
R1 input switch terminal screws	0.8
R3 input switch terminal screws	2.0

[efesotomasyon.com](http://efesotomasyon.com)

# Electrical installation

---

## What this chapter contains

The chapter describes the electrical installation procedure of the drive.



---

**WARNING!** The work described in this chapter may only be carried out by a qualified electrician. Follow the instructions in chapter *Safety* on page 5. Ignoring the safety instructions can cause injury or death.

**Make sure that the drive is disconnected from the input power during installation. If the drive is already connected to the input power, wait for 5 minutes after disconnecting the input power.**

---

## Checking the insulation of the assembly

See the ACS350 User's Manual.

## Connecting the power cables

### Connection diagram

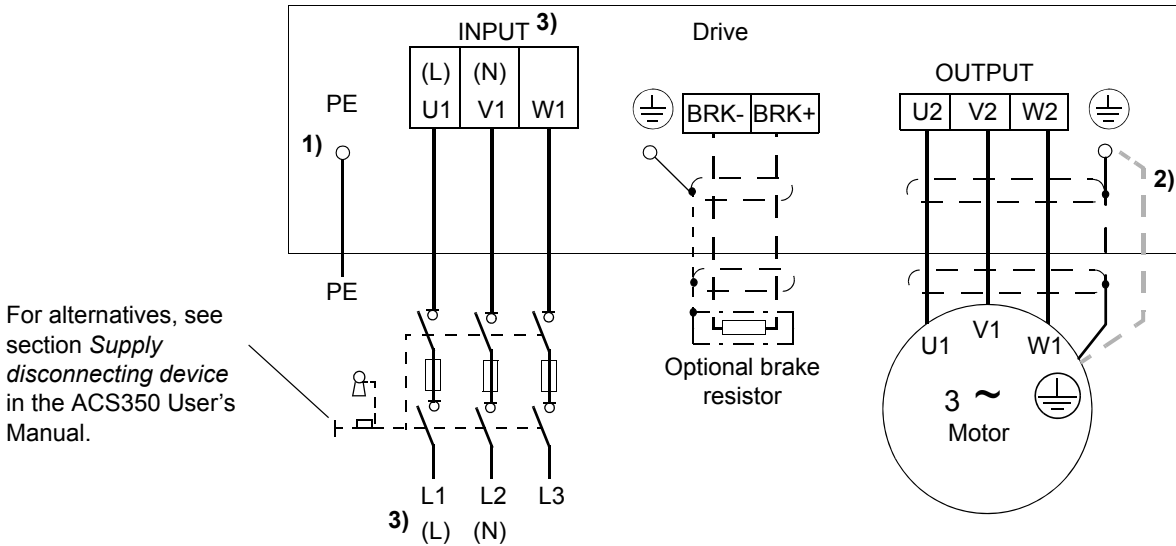

- 1) Ground the other end of the PE conductor at the distribution board.
- 2) Use a separate grounding cable if the conductivity of the cable shield is insufficient (smaller than the conductivity of the phase conductor) and there is no symmetrically constructed grounding conductor in the cable (see section *Selecting the power cables* in the ACS350 User's Manual).
- 3) L and N are connection markings for 1-phase supply.

**Note:**

Do not use an asymmetrically constructed motor cable.

If there is a symmetrically constructed grounding conductor in the motor cable in addition to the conductive shield, connect the grounding conductor to the grounding terminal at the drive and motor ends.

**Grounding of the motor cable shield at the motor end**

For minimum radio frequency interference:

- ground the cable by twisting the shield as follows: flattened width  $\geq 1/5 \cdot \text{length}$
- or ground the cable shield 360 degrees at the lead-through of the motor terminal box.

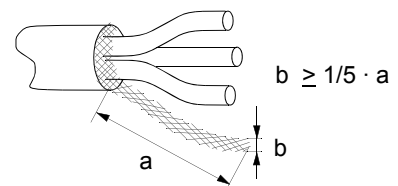

## Procedure

1. On IT (ungrounded) systems and corner grounded TN systems, disconnect the internal EMC filter by removing the EMC screw. For 3-phase U-type drives (with type code ACS350-03U-), the EMC screw is already removed at the factory and replaced by a plastic one.



**WARNING!** If a drive whose EMC filter is not disconnected is installed on an IT system [an ungrounded power system or a high resistance-grounded (over 30 ohms) power system], the system will be connected to earth potential through the EMC filter capacitors of the drive. This may cause danger or damage the drive.

If a drive whose EMC filter is not disconnected is installed on a corner grounded TN system, the drive will be damaged.

2. Fasten the grounding conductor (PE) of the input power cable under the grounding clamp. Connect the phase conductors to the U1, V1 and W1 terminals. Use a tightening torque of 0.8 N·m (7 lbf in.) for frame size R1 and 1.7 N·m (15 lbf in.) for R3.
3. Strip the motor cable and twist the shield to form as short a pigtail as possible. Fasten the twisted shield under the grounding clamp. Connect the phase conductors to the U2, V2 and W2 terminals. Use a tightening torque of 0.8 N·m (7 lbf in.) for frame size R1 and 1.7 N·m (15 lbf in.) for R3.
4. Connect the optional brake resistor to the BRK+ and BRK- terminals with a shielded cable using the same procedure as for the motor cable in step 3.
5. Secure the cables outside the drive mechanically.

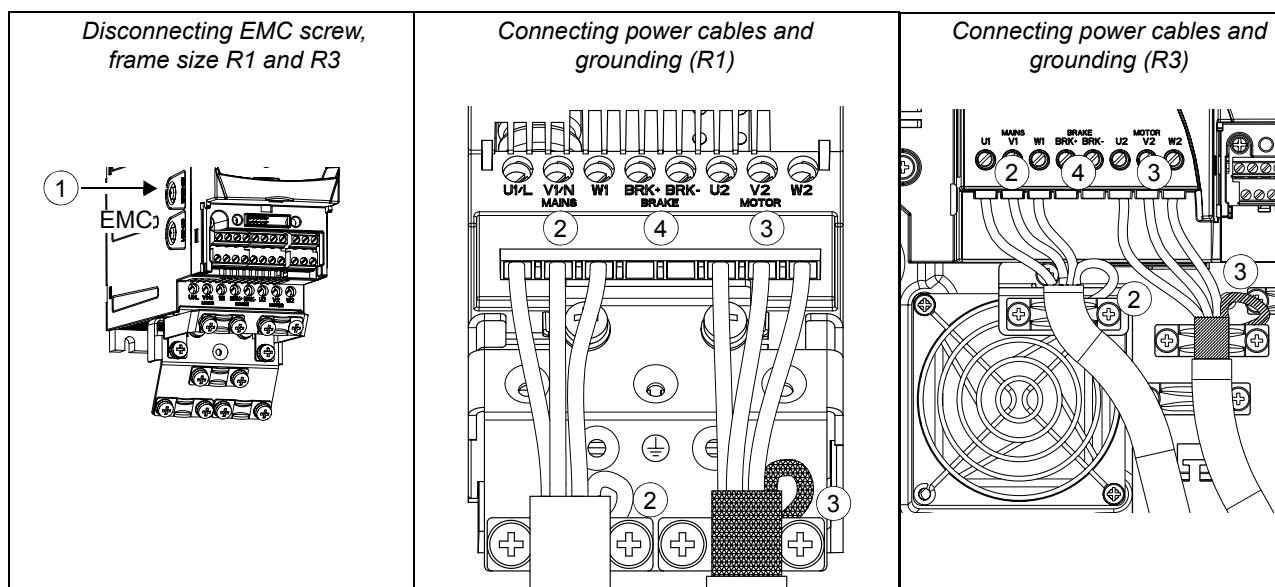

## **Connecting the control cables**

See the ACS350 User's Manual.

# Installation checklist

---

## Checklist

Check the mechanical and electrical installation of the drive before start-up. Go through the checklist below together with another person. Read chapter *Safety* on the first pages of this manual before you work on the drive.

Check
<p><b>MECHANICAL INSTALLATION</b></p> <ul style="list-style-type: none"> <li><input type="checkbox"/> The ambient operating conditions are allowed. (See <i>Mechanical installation: Requirements for the installation site</i> on page 23, <i>Technical data: Cooling air flow requirements</i> on page 39, <i>Power cable sizes and fuses</i> on page 40 and <i>Ambient conditions</i> on page 42.)</li> <li><input type="checkbox"/> The drive is fixed properly on an even vertical non-flammable wall. (See <i>Mechanical installation</i>.)</li> <li><input type="checkbox"/> The cooling air will flow freely. (See <i>Mechanical installation: Free space around the drive</i> on page 23.)</li> <li><input type="checkbox"/> The motor and the driven equipment are ready for start. (See <i>Planning electrical installation: Motor selection in the ACS350 User's Manual</i> and <i>Technical data: Motor connection</i> on page 41.)</li> <li><input type="checkbox"/> There are no foreign objects inside the drive. Only installations instructed in this manual or the ACS350 User's Manual are allowed.</li> </ul> <p><b>ELECTRICAL INSTALLATION</b> (See <i>Planning electrical installation</i> and <i>Electrical installation</i>.)</p> <ul style="list-style-type: none"> <li><input type="checkbox"/> For ungrounded and corner grounded systems: The internal EMC filter is disconnected (EMC screw removed).</li> <li><input type="checkbox"/> The capacitors are reformed if the drive has been stored over two years.</li> <li><input type="checkbox"/> The drive is grounded properly. <b>Note:</b> Lead-throughs may not be used for grounding.</li> <li><input type="checkbox"/> The input power voltage matches the drive nominal input voltage.</li> <li><input type="checkbox"/> The input power connections at U1, V1 and W1 are OK and tightened with the correct torque.</li> <li><input type="checkbox"/> Appropriate input power fuses and disconnectors are installed.</li> <li><input type="checkbox"/> The motor connections at U2, V2 and W2 are OK and tightened with the correct torque.</li> <li><input type="checkbox"/> The motor cable is routed away from other cables.</li> <li><input type="checkbox"/> The external control (I/O) connections are OK.</li> <li><input type="checkbox"/> The input power voltage cannot be applied to the output of the drive (with a bypass connection).</li> </ul>

**Check**

- Cable glands are tightened and the cover is in place.
- The gaskets are in place.

# Maintenance and hardware diagnostics

---

## What this chapter contains

The chapter contains preventive maintenance instructions and LED indicator descriptions.

## Safety



**WARNING!** Read the instructions in chapter *Safety* on the first pages of this manual before performing any maintenance on the equipment. Ignoring the safety instructions can cause injury or death.

---

## Maintenance intervals

If installed in an appropriate environment, the drive requires very little maintenance. The table lists the routine maintenance intervals recommended by ABB.

Maintenance	Interval	Instruction
Reforming of capacitors	Every two years when stored	See Capacitors in the ACS350 User's Manual.
Internal cooling fan replacement	Every three years	See <i>Internal fan</i> on page 34.
Replacement of the battery in the Assistant Control Panel	Every ten years	See <i>Battery</i> in the ACS350 User's Manual.

[efesotomasyon.com](http://efesotomasyon.com)

---

## Cleaning the drive

### Basic cleaning

1. Remove any loose dirt.
2. If necessary, hose down the drive.

### Thorough cleaning

1. Switch off the mains power.
2. Ensure the drive is dry.
3. Detach the control panel (a), cover (b) and cable glands (c).  
**Note:** Ensure that water or dust does not enter the drive.
4. Clean the components and gaskets with a damp, clean piece of cloth.
5. Re-assemble the drive and check the gaskets visually.
6. Perform basic cleaning.

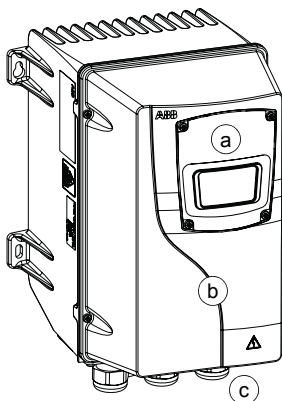

## Internal fan

The drive's internal cooling fan has a life span of approximately 25 000 operating hours. The actual life span depends on the drive usage and ambient temperature.

If the drive is operated in a critical part of a process, fan replacement is recommended before it has been in use for 25 000 hours or three years.

Replacement fans are available from ABB. Do not use other than ABB specified spare parts.

The factory setting for the operating hour counter (parameter 2901, see the ACS350 User's Manual) is 23 000 hours. The Notice Handler Assistant informs you when the drive has been in use for the defined number of hours.

### Internal fan replacement

1. Stop the drive and disconnect it from the AC power source.
2. Remove the front cover.
3. Open the screw(s) holding the fan in place (1 screw in R1, 2 screws in R3)
4. Free the fan cable from the clip.
5. Disconnect the fan cable.
6. Remove the fan holder.
7. Install the new fan in reverse order. The tightening torque is 1.2 N·m for all screws.
8. Restore power.

R1

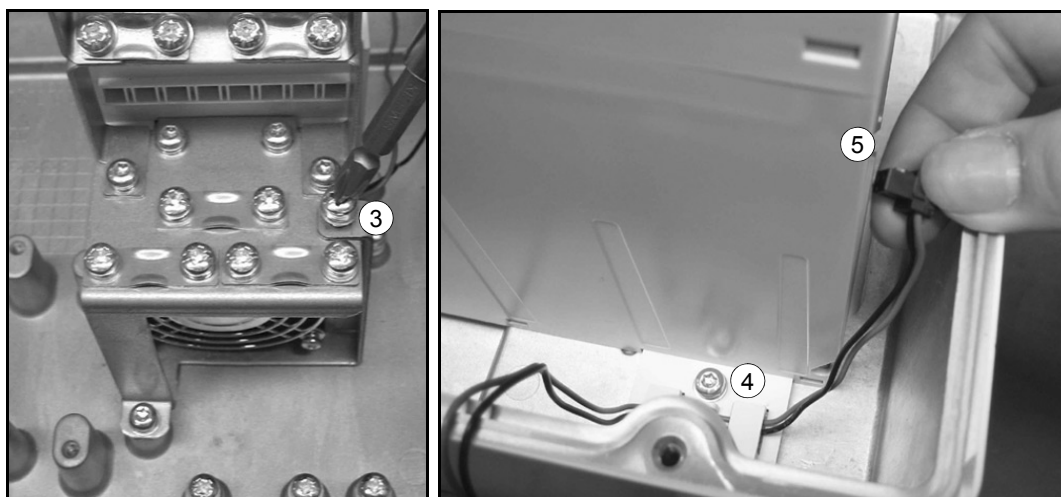

R3

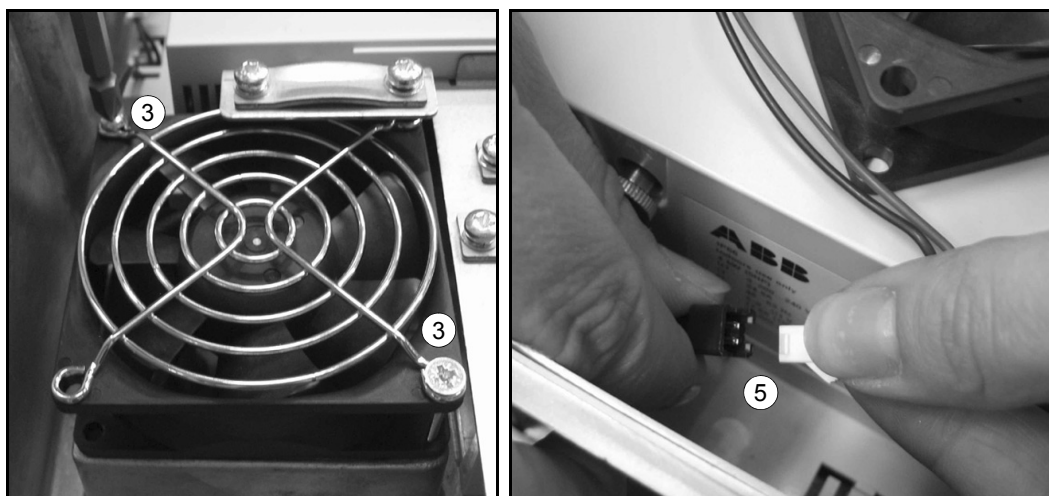



# Technical data

---

## What this chapter contains

The chapter contains the technical specifications of the drive, e.g. the ratings, sizes and technical requirements as well as provisions for fulfilling the requirements for CE and other marks.

## Ratings

### Current and power

The current and power ratings are given below. The symbols are described below the table.

Type ACS350... (+B063) x = E/U <sup>1)</sup>	Input	Output					Frame size
		$I_{1N}$ A	$I_{2N}$ A	$I_{2,1min/10min}$ A	$I_{2max}$ A	$P_N$	
	kW					HP	
<b>3-phase <math>U_N = 200...240</math> V (200, 208, 220, 230, 240 V)</b>							
03x-02A4-2	4.3	2.4	3.6	4.2	0.37	0.5	R1
03x-03A5-2	6.1	3.5	5.3	6.1	0.55	0.75	R1
03x-04A7-2	7.6	4.7	7.1	8.2	0.75	1	R1
03x-06A7-2	11.8	6.7	10.1	11.7	1.1	1.5	R1
03x-07A5-2	12.0	7.5	11.3	13.1	1.5	2	R1
03x-09A8-2	14.3	9.8	14.7	17.2	2.2	3	R3
03x-13A3-2	21.7	13.3	20.0	23.3	3	3	R3
03x-17A6-2	24.8	17.6	26.4	30.8	4	5	R3
<b>3-phase <math>U_N = 380...480</math> V (380, 400, 415, 440, 460, 480 V)</b>							
03x-01A2-4	2.2	1.2	1.8	2.1	0.37	0.5	R1
03x-01A9-4	3.6	1.9	2.9	3.3	0.55	0.75	R1
03x-02A4-4	4.1	2.4	3.6	4.2	0.75	1	R1
03x-03A3-4	6.0	3.3	5.0	5.8	1.1	1.5	R1
03x-04A1-4	6.9	4.1	6.2	7.2	1.5	2	R1
03x-05A6-4	9.6	5.6	8.4	9.8	2.2	3	R1
03x-07A3-4	11.6	7.3	11.0	12.8	3	3	R1
03x-08A8-4	13.6	8.8	13.2	15.4	4	5	R1
03x-12A5-4	18.8	12.5	18.8	21.9	5.5	7.5	R3
03x-15A6-4	22.1	15.6	23.4	27.3	7.5	10	R3

<sup>1)</sup> E = EMC filter connected, U = EMC filter disconnected. Metal EMC filter screw is installed in "E" versions and plastic screw in "U" versions.

### Symbols

#### Input

$I_{1N}$  continuous rms input current (for dimensioning cables and fuses)

#### Output

$I_{2N}$  continuous rms current. 50% overload is allowed for one minute every ten minutes.

$I_{2,1min/10min}$  maximum (50% overload) current allowed for one minute every ten minutes

$I_{2max}$  maximum output current. Available for two seconds at start, otherwise as long as allowed by the drive temperature.

$P_N$  typical motor power. The kilowatt ratings apply to most IEC 4-pole motors. The horsepower ratings apply to most NEMA 4-pole motors.

## Sizing

The current ratings are the same regardless of the supply voltage within one voltage range. To achieve the rated motor power given in the table, the rated current of the drive must be higher than or equal to the rated motor current.

**Note 1:** The maximum allowed motor shaft power is limited to  $1.5 \cdot P_N$ . If the limit is exceeded, motor torque and current are automatically restricted. The function protects the input bridge of the drive against overload.

**Note 2:** The ratings apply at ambient temperature of 40°C (104°F).

## Derating

The load capacity decreases if the installation site ambient temperature exceeds 40°C (104°F) or if the altitude exceeds 1000 meters (3300 ft). Derating is not allowed.

## Cooling air flow requirements

The table below specifies the heat dissipation in the main circuit at nominal load and in the control circuit with minimum load (I/O and panel not in use) and maximum load (all digital inputs in the on state and the panel, fieldbus and fan in use). The total heat dissipation is the sum of the heat dissipation in the main and control circuits.

Type	Heat dissipation						Air flow		
	Main circuit		Control circuit						
	x = E/U	Rated $I_{1N}$ and $I_{2N}$		Min		Max		m <sup>3</sup> /h	ft <sup>3</sup> /min
	W	BTU/Hr	W	BTU/Hr	W	BTU/Hr			
<b>3-phase <math>U_N = 200...240</math> V (200, 208, 220, 230, 240 V)</b>									
03x-02A4-2	19	65	6.1	21	22.7	78	-	-	
03x-03A5-2	31	106	6.1	21	22.7	78	-	-	
03x-04A7-2	38	130	9.5	32	26.4	90	-	-	
03x-06A7-2	60	205	9.5	32	26.4	90	-	-	
03x-07A5-2	62	212	9.5	32	26.4	90	-	-	
03x-09A8-2	83	283	10.5	36	27.5	94	-	-	
03x-13A3-2	112	383	10.5	36	27.5	94	-	-	
03x-17A6-2	152	519	10.5	36	27.5	94	-	-	
<b>3-phase <math>U_N = 380...480</math> V (380, 400, 415, 440, 460, 480 V)</b>									
03x-01A2-4	11	38	6.6	23	24.4	83	-	-	
03x-01A9-4	16	55	6.6	23	24.4	83	-	-	
03x-02A4-4	21	72	9.8	33	28.7	98	-	-	
03x-03A3-4	31	106	9.8	33	28.7	98	-	-	
03x-04A1-4	40	137	9.8	33	28.7	98	-	-	
03x-05A6-4	61	208	9.8	33	28.7	98	-	-	
03x-07A3-4	74	253	14.1	48	32.7	112	-	-	
03x-08A8-4	94	321	14.1	48	32.7	112	-	-	
03x-12A5-4	130	444	12.0	41	31.2	107	-	-	
03x-15A6-4	173	591	12.0	41	31.2	107	-	-	

00353783.xls G

## Power cable sizes and fuses

Cable dimensioning for rated currents ( $I_{1N}$ ) is shown in the table below together with the corresponding fuse types for short-circuit protection of the input power cable.

**The rated fuse currents given in the table are the maximum for the mentioned fuse types.** If smaller fuse ratings are used, check that the fuse rms current rating is larger than the rated  $I_{1N}$  current given in the rating table on page 38. If 150% output power is needed, multiply current  $I_{1N}$  by 1.5.

**Check that the operating time of the fuse is below 0.5 seconds.** The operating time depends on the fuse type, the supply network impedance as well as the cross-sectional area, material and length of the supply cable. In case the 0.5 seconds operating time is exceeded with the gG or T fuses, ultra rapid (aR) fuses will in most cases reduce the operating time to an acceptable level.

### Cable temperature ratings and sizes

Use power cables with a temperature rating of at least 70°C (158°F) maximum permissible temperature of the conductor in continuous use. However, if you use cables smaller than shown in the table below, use cables with a temperature rating of 90°C (194°F).

#### Additional US requirements

If metallic conduit is not used, type MC continuous corrugated aluminium armor cable with symmetrical grounds or shielded power cable is recommended. The power cables must be rated for 75°C (167°F).

Type ACS350- x = E/U	Fuses		Size of CU conductor in cabling							
	gG	UL Class T (600 V)	Supply (U1, V1, W1)		Motor (U2, V2, W2)		PE		Brake (BRK+ and BRK-)	
	A	A	mm <sup>2</sup>	AWG	mm <sup>2</sup>	AWG	mm <sup>2</sup>	AWG	mm <sup>2</sup>	AWG
<b>3-phase <math>U_N = 200...240</math> V (200, 208, 220, 230, 240 V)</b>										
03x-02A4-2	10	10	2.5	14	0.75	18	2.5	14	2.5	14
03x-03A5-2	10	10	2.5	14	0.75	18	2.5	14	2.5	14
03x-04A7-2	10	15	2.5	14	0.75	18	2.5	14	2.5	14
03x-06A7-2	16	15	2.5	12	1.5	14	2.5	12	2.5	12
03x-07A5-2	16	15	2.5	12	1.5	14	2.5	12	2.5	12
03x-09A8-2	16	20	2.5	12	2.5	12	2.5	12	2.5	12
03x-13A3-2	25	30	6	10	6	10	6	10	2.5	12
03x-17A6-2	25	35	6	10	6	10	6	10	2.5	12
<b>3-phase <math>U_N = 380...480</math> V (380, 400, 415, 440, 460, 480 V)</b>										
03x-01A2-4	10	10	2.5	14	0.75	18	2.5	14	2.5	14
03x-01A9-4	10	10	2.5	14	0.75	18	2.5	14	2.5	14
03x-02A4-4	10	10	2.5	14	0.75	18	2.5	14	2.5	14
03x-03A3-4	10	10	2.5	12	0.75	18	2.5	12	2.5	12
03x-04A1-4	16	15	2.5	12	0.75	18	2.5	12	2.5	12
03x-05A6-4	16	15	2.5	12	1.5	14	2.5	12	2.5	12
03x-07A3-4	16	20	2.5	12	1.5	14	2.5	12	2.5	12
03x-08A8-4	20	25	2.5	12	2.5	12	2.5	12	2.5	12
03x-12A5-4	25	30	6	10	6	10	6	10	2.5	12
03x-15A6-4	35	35	6	8	6	8	6	8	2.5	12

00353783.xls H

## I/O cables

Use I/O cables with a temperature rating of at least 70°C (158°F) maximum permissible temperature of the conductor in continuous use.

## Power cables: terminal sizes, maximum cable diameters and tightening torques

See the ACS350 User's Manual.

## Dimensions, weights and noise

Frame size	Dimensions and weights												Noise
	IP66/67 UL Type 4X												Noise level
	H1		H2		H3		W		D		Weight		
	mm	in.	mm	in.	mm	in.	mm	in.	mm	in.	kg	lb	dBA
R1	305	12.0	346	13.6	189	7.4	195	7.7	281	11.1	7.7	17.0	<50
R3	436	17.2	477	18.8	300	11.8	246	9.7	277	10.9	13.0	28.7	<50

00353783.xls G

H1	Height from top to bottom
H2	Height from top to bottom with cable glands
H3	Height between mounting brackets

## Input power connection

See the ACS350 User's Manual.

## Motor connection

See the ACS350 User's Manual.

## Control connections

Wire size	Solid or stranded	0.14...1.5 mm <sup>2</sup>
	Stranded with ferrule (with or without plastic sleeve)	0.25...1.5 mm <sup>2</sup>
	AWG/kcmil	26...16
Torque		0.4 N·m (3.5 lbf·in.)

For more information on control connections, see the ACS350 User's Manual.

## Brake resistor connection

See the ACS350 User's Manual.

## Efficiency

See the ACS350 User's Manual.

## Cooling

Method	R1 and R3: Internal fan (natural convection cooling).
Free space around the drive	See chapter <i>Mechanical installation</i> , page 23.

## Degrees of protection

IP66/67 UL Type 4X, indoor use only.  
IP69K with compatible cable glands

## Ambient conditions

Environmental limits for the drive are given below. The drive is to be used in a heated indoor controlled environment.

	<b>Operation</b> installed for stationary use	<b>Storage</b> in the protective package	<b>Transportation</b> in the protective package
<b>Installation site altitude</b>	0 to 1000 m (3300 ft) above sea level	-	-
<b>Air temperature</b>	0 to +40°C (32 to 104°F). No frost allowed. See section <i>Derating</i> on page 39.	-40 to +70°C (-40 to +158°F)	-40 to +70°C (-40 to +158°F)
<b>Relative humidity</b>	0 to 100%	Max. 95%	Max. 95%
	No condensation allowed. Use a pressure compensation valve to avoid condensation (see <i>Type code</i> on page 19). Maximum allowed relative humidity is 60% in the presence of corrosive gases.		
<b>Contamination levels</b> (IEC 60721-3-3, IEC 60721-3-2, IEC 60721-3-1)	No conductive dust allowed. According to IEC 60721-3-3, chemical gases: Class 3C2 solid particles: Class 3S2.	According to IEC 60721-3-1, chemical gases: Class 1C2 solid particles: Class 1S2	According to IEC 60721-3-2, chemical gases: Class 2C2 solid particles: Class 2S2
<b>Sinusoidal vibration</b> (IEC 60721-3-3)	Tested according to IEC 60721-3-3, mechanical conditions: Class 3M4 2...9 Hz, 3.0 mm (0.12 in.) 9...200 Hz, 10 m/s <sup>2</sup> (33 ft/s <sup>2</sup> )	-	-
<b>Shock</b> (IEC 60068-2-27, ISTA 3A-Standard)	-	According to ISTA 3A-Standard. Max. 100 m/s <sup>2</sup> (330 ft/s <sup>2</sup> ), 11 ms.	According to ISTA 3A-Standard. Max. 100 m/s <sup>2</sup> (330 ft/s <sup>2</sup> ), 11 ms.
<b>Free fall</b>	Not allowed	76 cm (30 in.)	76 cm (30 in.)

## Materials

### Drive enclosure

- PC
- PC+10%GF
- PC/ABS
- PA66
- TPV
- hot-dip zinc coated steel sheet
- extruded aluminum
- polyester-based powder coating aluminum
- stainless steel

### Package

Corrugated cardboard.

**Disposal**

The drive contains raw materials that should be recycled to preserve energy and natural resources. The package materials are environmentally compatible and recyclable. All metal parts can be recycled. The plastic parts can either be recycled or burned under controlled circumstances, according to local regulations. Most recyclable parts are marked with recycling marks.

If recycling is not feasible, all parts excluding electrolytic capacitors and printed circuit boards can be landfilled. The DC capacitors contain electrolyte, which is classified as hazardous waste within the EU. They must be removed and handled according to local regulations.

For further information on environmental aspects and more detailed recycling instructions, please contact your local ABB distributor.

**Applicable standards**

---

	The drive complies with the following standards:
• IEC/EN 61800-5-1 (2003)	Electrical, thermal and functional safety requirements for adjustable frequency a.c. power drives
• IEC/EN 60204-1 (1997) + Amendment A1 (1999)	Safety of machinery. Electrical equipment of machines. Part 1: General requirements. <i>Provisions for compliance:</i> The final assembler of the machine is responsible for installing - an emergency-stop device - a supply disconnecting device.
• IEC/EN 61800-3 (2004)	Adjustable speed electrical power drive systems. Part 3: EMC requirements and specific test methods
• IEC 60529 (1989) + Amendment A1 (1999) EN 60529 (1991) + Amendment A1 (2000)	Degrees of protection provided by enclosures (IP Code)
• UL 508C	UL Standard for Safety, Power Conversion Equipment, third edition
• DIN40050-9 (1993)	Road vehicles; degrees of protection (IP69K); protection against foreign objects; water and contact; electrical equipment

**CE marking**

A CE mark is attached to the drive to verify that the drive follows the provisions of the European Low Voltage Directive (2006/95/EC) and EMC Directive (2004/108EC).

**Compliance with the EMC Directive**

The EMC Directive defines the requirements for immunity and emissions of electrical equipment used within the European Union. The EMC product standard [EN 61800-3 (2004)] covers requirements stated for drives.

**Compliance with EN 61800-3 (2004)**

See page 45.

**NSF mark**

The presence on the NSF Mark on food service equipment means that the equipment has been evaluated, tested, and certified by NSF International as meeting international commercial food equipment standards. To earn the right to use the NSF Mark, a manufacturer must pass not only stringent evaluation and testing of its product, but also rigorous, unannounced inspection of its production facilities which are contacted on a routine basis.

## RoHS marking

The RoHS mark is attached to the drive to verify that drive follows the provisions of the European RoHS Directive. RoHS = the restriction of the use of certain hazardous substances in electrical and electronic equipment.

## UL marking

See the type designation label for the valid markings of your drive.

The UL mark is attached to the drive to verify that it meets UL requirements.

### *UL checklist*

**Input power connection** – See section *Input power connection* on page 41.

**Disconnecting device (disconnecting means)** – See section Supply disconnecting device in the ACS350 User's Manual.

**Ambient conditions** – The drives are to be used in a heated indoor controlled environment. See section *Ambient conditions* on page 42 for specific limits.

**Input cable fuses** – For installation in the United States, branch circuit protection must be provided in accordance with the National Electrical Code (NEC) and any applicable local codes. To fulfil this requirement, use the UL classified fuses given in section *Power cable sizes and fuses* on page 40.

For installation in Canada, branch circuit protection must be provided in accordance with Canadian Electrical Code and any applicable provincial codes. To fulfil this requirement, use the UL classified fuses given in section *Power cable sizes and fuses* on page 40.

**Power cable selection** – See section *Power cable sizes and fuses* on page 40.

**Power cable connections** – For the connection diagram and tightening torques, see section *Connecting the power cables* on page 28.

**Overload protection** – The drive provides overload protection in accordance with the National Electrical Code (US).

**Braking** – The drive has an internal brake chopper. When applied with appropriately sized brake resistors, the brake chopper will allow the drive to dissipate regenerative energy (normally associated with quickly decelerating a motor). Brake resistor selection is discussed in section *Brake resistors* on page 46.

## IEC/EN 61800-3 (2004) Definitions

EMC stands for **Electromagnetic Compatibility**. It is the ability of electrical/electronic equipment to operate without problems within an electromagnetic environment. Likewise, the equipment must not disturb or interfere with any other product or system within its locality.

*First environment* includes establishments connected to a low-voltage network which supplies buildings used for domestic purposes.

*Second environment* includes establishments connected to a network not directly supplying domestic premises.

*Drive of category C2*: drive of rated voltage less than 1000 V and intended to be installed and commissioned only by a professional when used in the first environment.

**Note:** A professional is a person or organisation having necessary skills in installing and/or commissioning power drive systems, including their EMC aspects.

Category C2 has the same EMC emission limits as the earlier class first environment restricted distribution. EMC standard IEC/EN 61800-3 does not any more restrict the distribution of the drive, but the using, installation and commissioning are defined.

*Drive of category C3*: drive of rated voltage less than 1000 V, intended for use in the second environment and not intended for use in the first environment.

Category C3 has the same EMC emission limits as the earlier class second environment unrestricted distribution.

## Compliance with the IEC/EN 61800-3 (2004)

The immunity performance of the drive complies with the demands of IEC/EN 61800-3, second environment (see page 44 for IEC/EN 61800-3 definitions). The emission limits of IEC/EN 61800-3 are complied with the provisions described below.

### *First environment (drives of category C2)*

1. The optional EMC filter is selected according to the ABB documentation and installed as specified in the EMC filter manual.
2. The motor and control cables are selected as specified in this manual.
3. The drive is installed according to the instructions given in this manual.
4. Motor cable length maximum 30 m (100 ft) with 4 kHz switching frequency.

**WARNING!** In a domestic environment, this product may cause radio interference, in which case supplementary mitigation measures may be required.

### *Second environment (drives of category C3)*

1. The internal EMC filter is connected (the metal screw at EMC is in place) or the optional EMC filter is installed.
2. The motor and control cables are selected as specified in this manual.
3. The drive is installed according to the instructions given in this manual.
4. With the internal EMC filter: motor cable length 30 m (100 ft) with 4 kHz switching frequency.

**WARNING!** A drive of category C3 is not intended to be used on a low-voltage public network which supplies domestic premises. Radio frequency interference is expected if the drive is used on such a network.

**Note:** It is not allowed to install a drive with the internal EMC filter connected on IT (ungrounded) systems. The supply network becomes connected to ground potential through the EMC filter capacitors which may cause danger or damage the drive.

**Note:** It is not allowed to install a drive with the internal EMC filter connected on a corner grounded TN system as this would damage the drive.

## Product protection in the USA

This product is protected by one or more of the following US patents:

4,920,306	5,301,085	5,463,302	5,521,483	5,532,568	5,589,754
5,612,604	5,654,624	5,799,805	5,940,286	5,942,874	5,952,613
6,094,364	6,147,887	6,175,256	6,184,740	6,195,274	6,229,356
6,252,436	6,265,724	6,305,464	6,313,599	6,316,896	6,335,607
6,370,049	6,396,236	6,448,735	6,498,452	6,552,510	6,597,148
6,600,290	6,741,059	6,774,758	6,844,794	6,856,502	6,859,374
6,922,883	6,940,253	6,934,169	6,956,352	6,958,923	6,967,453
6,972,976	6,977,449	6,984,958	6,985,371	6,992,908	6,999,329
7,023,160	7,034,510	7,036,223	7,045,987	7,057,908	7,059,390
7,067,997	7,082,374	7,084,604	7,098,623	7,102,325	7,109,780
7,164,562	7,176,779	7,190,599	7,215,099	7,221,152	7,227,325
7,245,197	7,250,739	7,262,577	7,271,505	7,274,573	7,279,802
7,280,938	7,330,095	7,349,814	7,352,220	7,365,622	7,372,696
7,388,765	D503,931	D510,319	D510,320	D511,137	D511,150
D512,026	D512,696	D521,466	D541,743S	D541,744S	D541,745S
D548,182S	D548,183S				

Other patents pending.

## Brake resistors

See the ACS350 User's Manual.

## Dimensions

---

Dimensional drawings of the ACS350 with IP66/67 UL Type 4X enclosure are shown below. The dimensions are given in millimeters and [inches].

Frame size R1, IP66/67 UL Type 4X

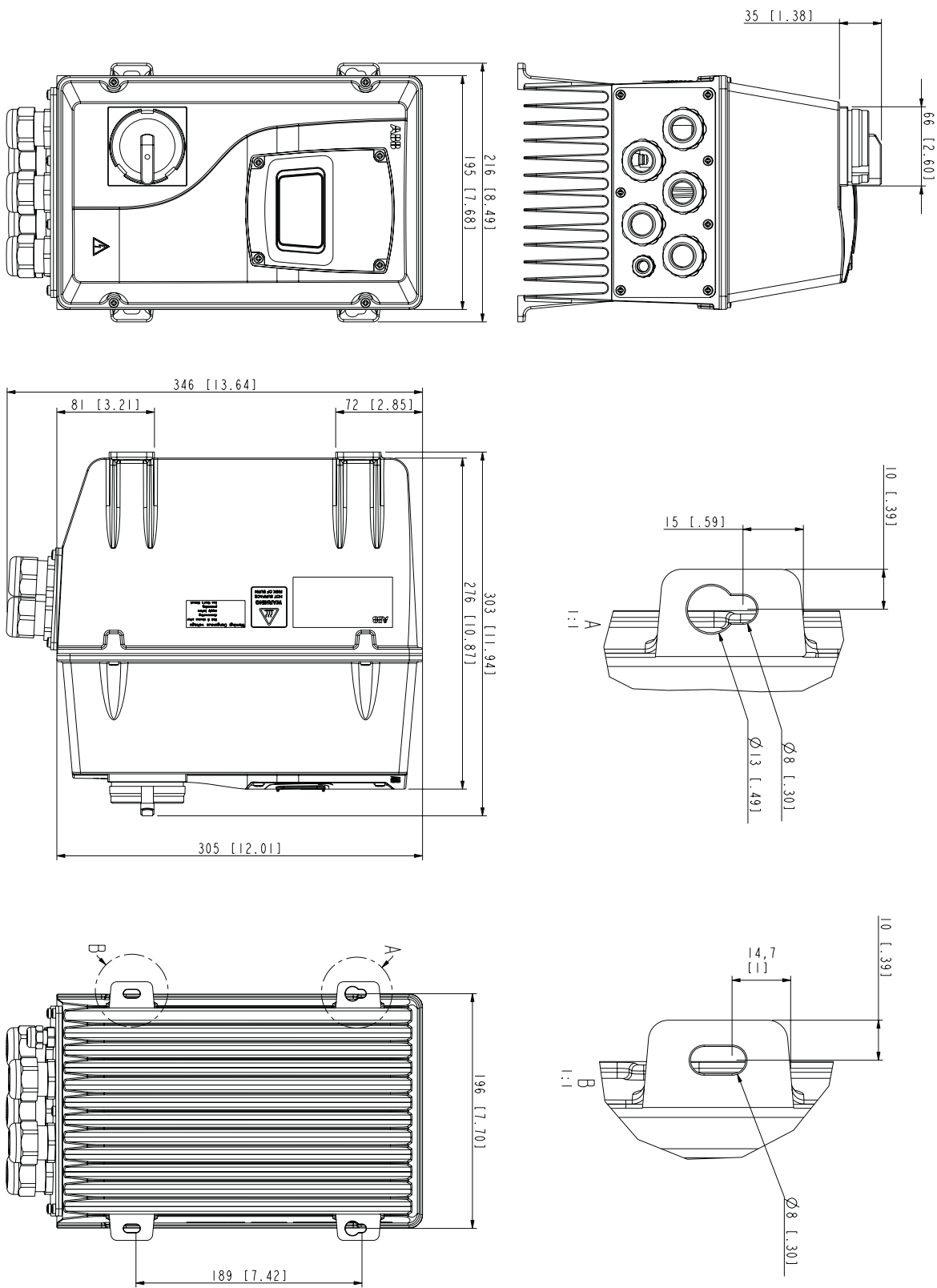

3AU0000050541

# Frame size R3, IP66/67 UL Type 4X

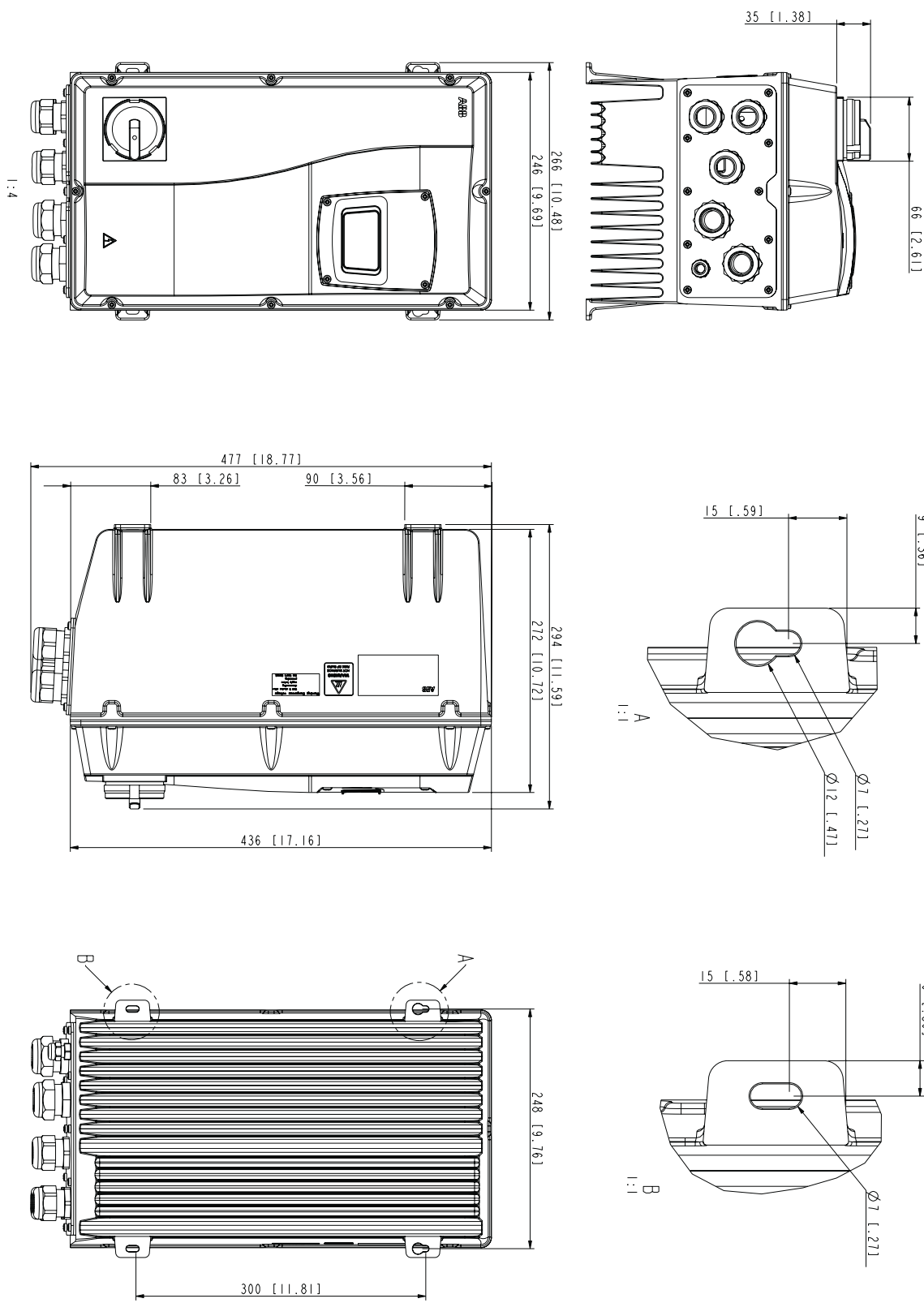

3AU0000050616

### R1 gland plate (EU)

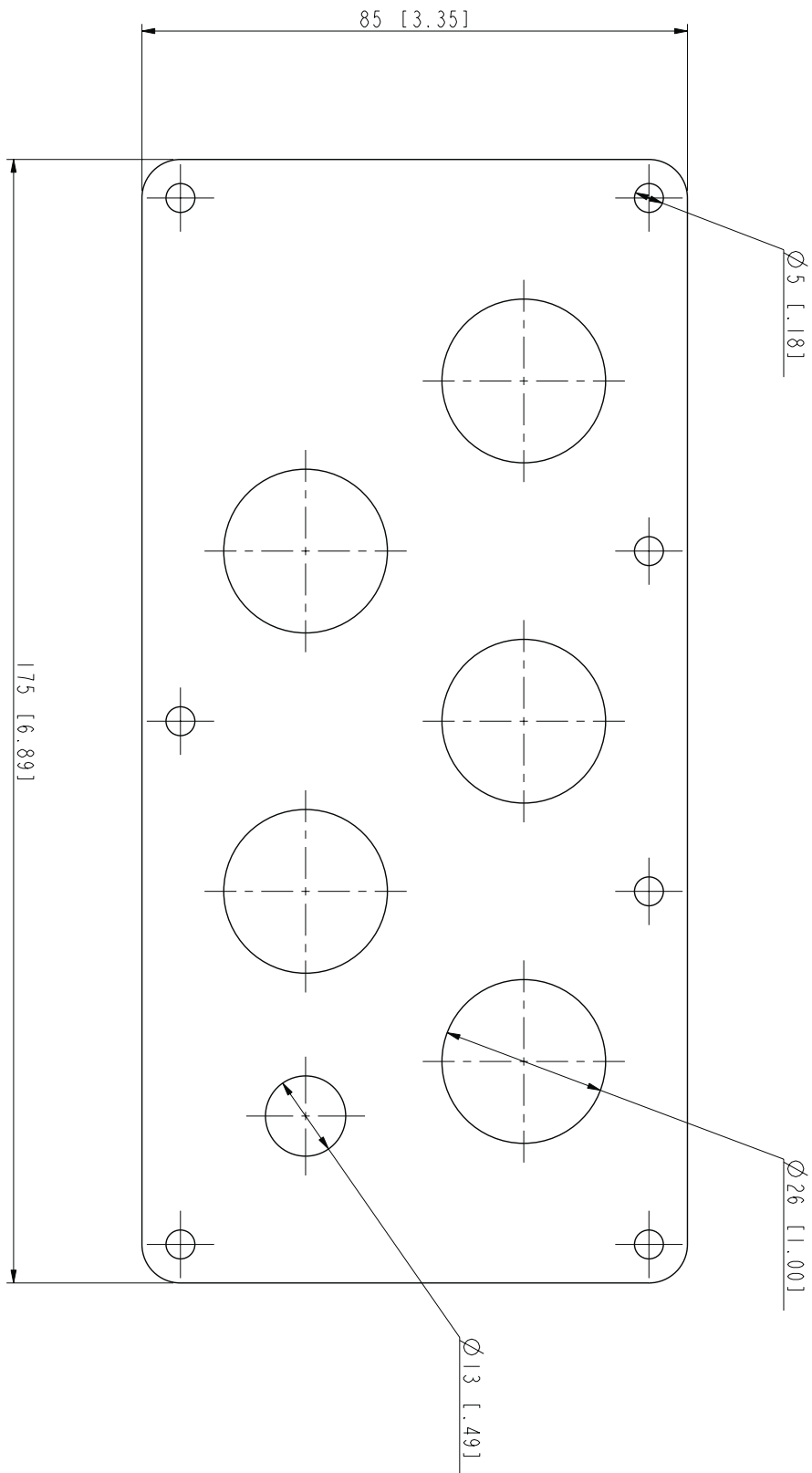

3ALJA0000039173

## R1 conduit fitting plate (US)

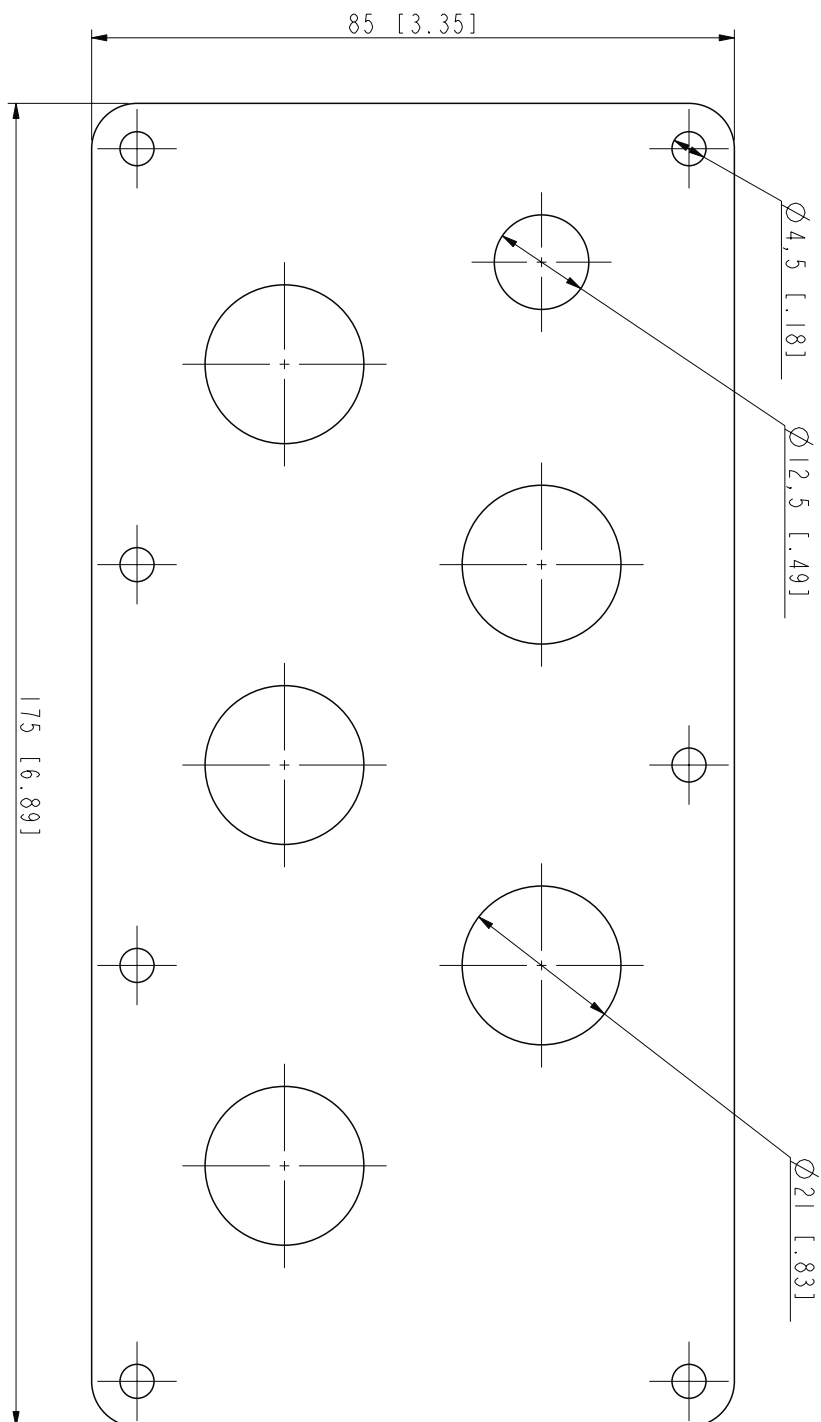

**Note:** The 12.5mm diameter hole is for the optional pressure compensation valve (+C169). Do not use it for any other purpose.

### R3 gland plate (EU)

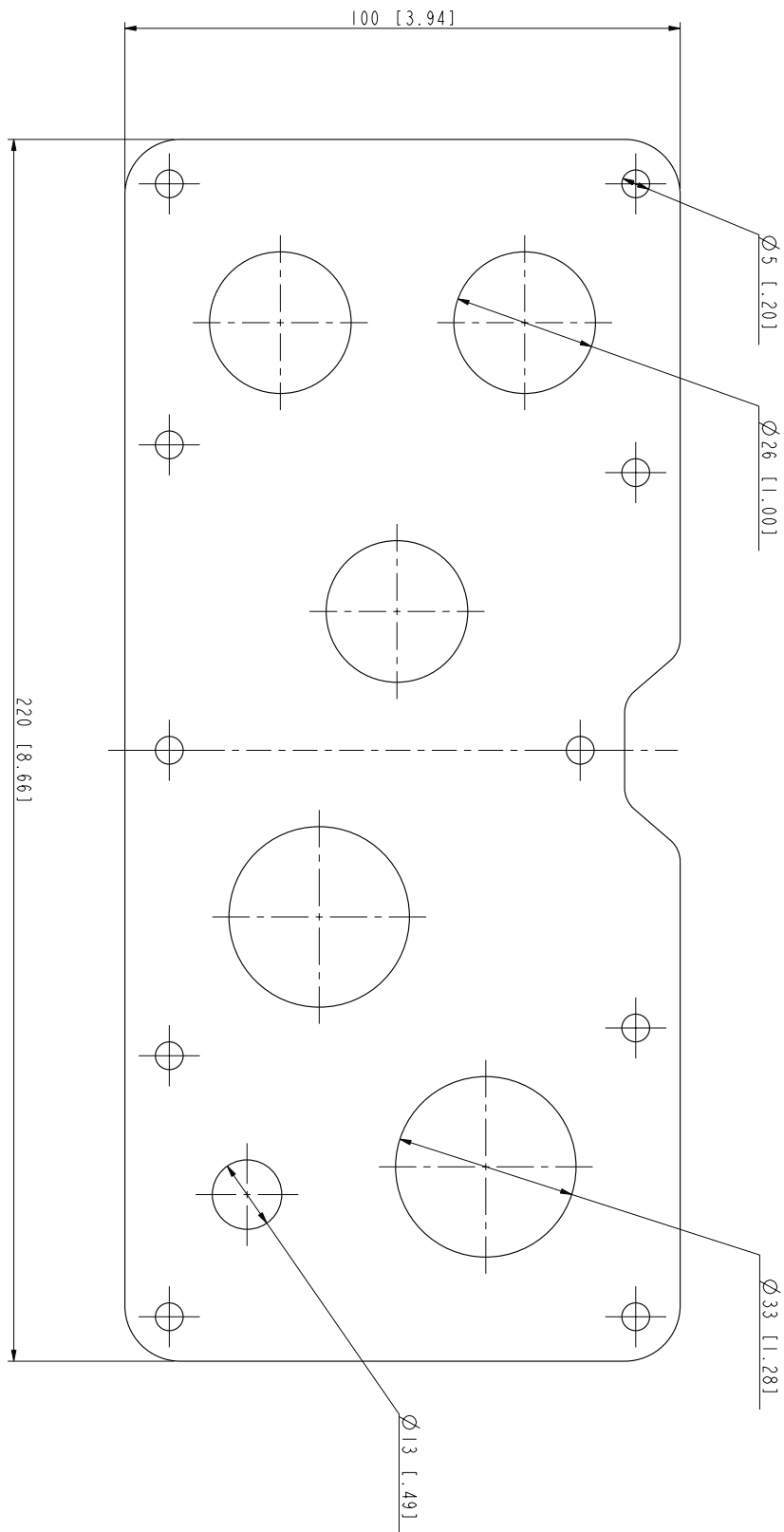

3ALU00000039181

## R3 conduit fitting plate (US)

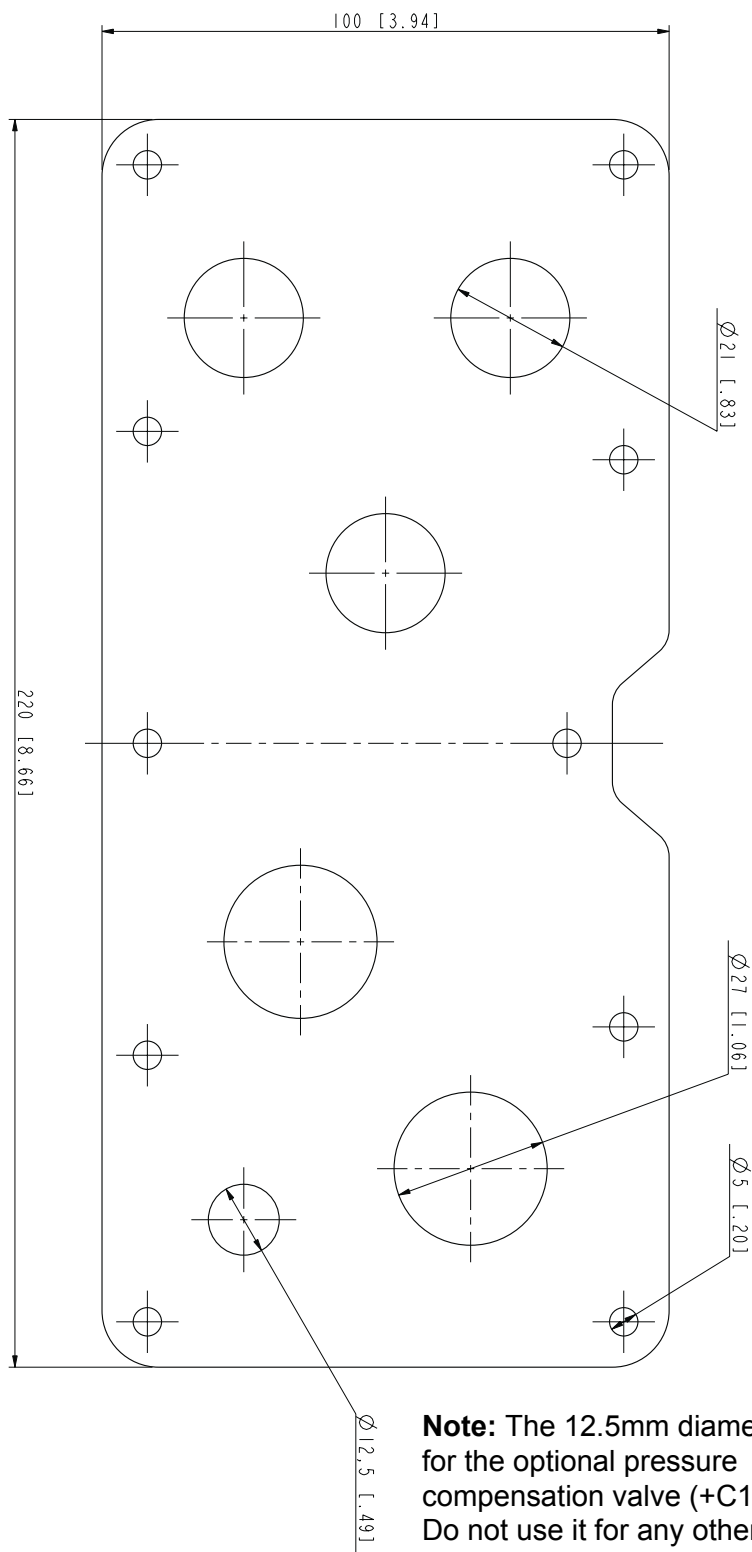

3AUA00000039182







**ABB Oy**  
AC Drives  
P.O. Box 184  
FI-00381 HELSINKI  
FINLAND  
Telephone +358 10 22 11  
Fax +358 10 22 22681  
Internet <http://www.abb.com>

**ABB Inc.**  
Automation Technologies  
Drives & Motors  
16250 West Glendale Drive  
New Berlin, WI 53151  
USA  
Telephone +1 262 785-3200  
+1 800-HELP-365  
Fax +1 262 780-5135

**ABB Limited**  
Daresbury Park  
Daresbury  
Warrington  
Cheshire  
WA4 4BT  
UNITED KINGDOM  
Telephone +44 1925 741111  
Fax +44 1925 741212

**ABB Beijing Drive Systems Co. Ltd.**  
No. 1, Block D, A-10 Jiuxianqiao Beilu  
Chaoyang District  
Beijing, P.R. China, 100015  
Telephone +86 10 5821 7788  
Fax +86 10 5821 7618  
Internet <http://www.abb.com>

3AUA0000042326 REV B / EN  
EFFECTIVE: 31.3.2009