

ABB general machinery drives

ACS350, 0.37 to 22 kW / 0.5 to 30 hp

efesotomasyon.com



ABB general machinery drives

ABB general machinery drives are designed for machine building. In serial type manufacturing the consumed time per unit is critical. The drives are designed to be the fastest drives in terms of installation, setting parameters and commissioning. The basic products have been made as user-friendly as possible, yet providing high intelligence. The drives offer diverse functionality to cater for the most demanding needs.

ABB general machinery drives are designed to meet the requirements of an extensive range of machinery applications. The drives are ideal for food and beverage, material handling, textile, printing, rubber and plastics, and woodworking applications.

Highlights

- Unified height and depth
- Side-by-side mounting
- Inbuilt C3 EMC filter
- Inbuilt brake chopper
- Easy programming
- Sequence programming
- FlashDrop tool for fast parameter setting

Voltage and power range

- 1-phase, 200 to 240 V \pm 10%
0.37 to 2.2 kW (0.5 to 3 hp)
- 3-phase, 200 to 240 V \pm 10%
0.37 to 11 kW (0.5 to 15 hp)
- 3-phase, 380 to 480 V \pm 10%
0.37 to 22 kW (0.5 to 30 hp)

Options

- User interface
 - Basic control panel
 - Assistant control panel
 - Potentiometer
- FlashDrop tool
- Fieldbuses
 - PROFIBUS DP
 - CANopen
 - DeviceNet
 - Modbus
 - Ethernet
- Encoder interface
- NEMA 1 kit
- Input/Output chokes
- C2 EMC filters
- DriveWindow Light 2 software

efesotomasyon.com

ABB

Ratings, types, voltages and dimensions



HANSAPRINT/SAL07_00609/2007

Ad agency Piiretek Oy #12340

Specifications subject to change without notice.

© Copyright 2007 ABB. All rights reserved. 3AFE68707218 REV C EN 8.10.2007

Ratings			Type code	Frame size	IP20 UL open				NEMA 1			
P_N kW	P_N hp	I_{2N} A			H2 mm	W mm	D mm	Weight kg	H5 mm	W mm	D mm	Weight kg
1-phase supply voltage 200 - 240 V units												
0.37	0.5	2.4	ACS350-01X-02A4-2	R0	202	70	161	1.1	280	70	169	1.5
0.75	1	4.7	ACS350-01X-04A7-2	R1	202	70	161	1.3	280	70	169	1.7
1.1	1.5	6.7	ACS350-01X-06A7-2	R1	202	70	161	1.3	280	70	169	1.7
1.5	2	7.5	ACS350-01X-07A5-2	R2	202	105	165	1.5	282	105	169	1.9
2.2	3	9.8	ACS350-01X-09A8-2	R2	202	105	165	1.5	282	105	169	1.9
3-phase supply voltage 200 - 240 V units												
0.37	0.5	2.4	ACS350-03X-02A4-2	R0	202	70	161	1.1	280	70	169	1.5
0.55	0.75	3.5	ACS350-03X-03A5-2	R0	202	70	161	1.1	280	70	169	1.5
0.75	1	4.7	ACS350-03X-04A7-2	R1	202	70	161	1.3	280	70	169	1.7
1.1	1.5	6.7	ACS350-03X-06A7-2	R1	202	70	161	1.3	280	70	169	1.7
1.5	2	7.5	ACS350-03X-07A5-2	R1	202	70	161	1.3	280	70	169	1.7
2.2	3	9.8	ACS350-03X-09A8-2	R2	202	105	165	1.5	282	105	169	1.9
3	4	13.3	ACS350-03X-13A3-2	R2	202	105	165	1.5	282	105	169	1.9
4	5	17.6	ACS350-03X-17A6-2	R2	202	105	165	1.5	282	105	169	1.9
5.5	7.5	24.4	ACS350-03X-24A4-2	R3	202	169	169	2.5	299	169	177	3.1
7.5	10	31	ACS350-03X-31A0-2	R4	202	260	169	4.4	320	260	177	5.0
11	15	46.2	ACS350-03X-46A2-2	R4	202	260	169	4.4	320	260	177	5.0
3-phase supply voltage 380 - 480 V units												
0.37	0.5	1.2	ACS350-03X-01A2-4	R0	202	70	161	1.1	280	70	169	1.5
0.55	0.75	1.9	ACS350-03X-01A9-4	R0	202	70	161	1.1	280	70	169	1.5
0.75	1	2.4	ACS350-03X-02A4-4	R1	202	70	161	1.3	280	70	169	1.7
1.1	1.5	3.3	ACS350-03X-03A3-4	R1	202	70	161	1.3	280	70	169	1.7
1.5	2	4.1	ACS350-03X-04A1-4	R1	202	70	161	1.3	280	70	169	1.7
2.2	3	5.6	ACS350-03X-05A6-4	R1	202	70	161	1.3	280	70	169	1.7
3	4	7.3	ACS350-03X-07A3-4	R1	202	70	161	1.3	280	70	169	1.7
4	5	8.8	ACS350-03X-08A8-4	R1	202	70	161	1.3	280	70	169	1.7
5.5	7.5	12.5	ACS350-03X-12A5-4	R3	202	169	169	2.5	299	169	177	3.1
7.5	10	15.6	ACS350-03X-15A6-4	R3	202	169	169	2.5	299	169	177	3.1
11	15	23.1	ACS350-03X-23A1-4	R3	202	169	169	2.5	299	169	177	3.1
15	20	31	ACS350-03X-31A0-4	R4	202	260	169	4.4	320	260	177	5.0
18.5	25	38	ACS350-03X-38A0-4	R4	202	260	169	4.4	320	260	177	5.0
22	30	44	ACS350-03X-44A0-4	R4	202	260	169	4.4	320	260	177	5.0

X within the type code stands for E or U.
 E = EMC filter connected. U = EMC filter disconnected.
 H2 = Height with fastenings but without clamping plate.
 H5 = Height with fastenings, NEMA 1 connection box and hood.
 W = Width, D = Depth



ABB Oy
 Drives
 P. O. Box 184
 FI - 00381 Helsinki
 Finland
 Telephone +358 10 22 11
 Fax +358 10 22 23764
 Internet www.abb.com/drives

Motor connection

Voltage	3-phase, from 0 to U_{SUPPLY}
Frequency	0 to 500 Hz
Overload capacity (at a max. ambient temperature of 40 °C)	1.5 x I_{2N} for 1 minute every 10 minutes At start 1.8 x I_{2N} for 2 s
Switching frequency Default Selectable	4 kHz 4 to 16 kHz with 4 kHz steps
Speed control Static accuracy Dynamic accuracy	20% of motor nominal slip < 1% s with 100% torque step
Torque control Torque step rise time Non-linearity	< 10ms with nominal torque ± 5% with nominal torque

Programmable control connections

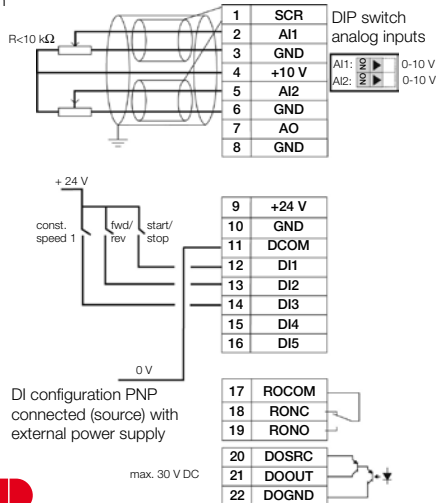
Two analog inputs Voltage signal Unipolar Bipolar Current signal Unipolar Bipolar Potentiometer reference value Resolution Accuracy	0 (2) to 10 V, $R_{in} > 312 \text{ k}\Omega$ -10 to 10 V, $R_{in} > 312 \text{ k}\Omega$ 0 (4) to 20 mA, $R_{in} = 100 \Omega$ -20 to 20 mA, $R_{in} = 100 \Omega$ 10 V ± 1% max. 10 mA, $R < 10 \text{ k}\Omega$ 0.1% ± 1%
One analog output	0 (4) to 20 mA, load < 500 Ω
Auxiliary voltage	24 V DC ± 10%, max. 200 mA
Five digital inputs Input impedance	12 to 24 V DC with internal or external supply, PNP and NPN, pulse train 0 to 16 kHz 2.4 k Ω
One relay output Type Maximum switching voltage Maximum switching current Maximum continuous current	NO + NC 250 V AC/30 V DC 0.5 A/30 V DC; 5 A/230 V AC 2 A rms
One digital output Type Maximum switching voltage Maximum switching current Frequency Resolution Accuracy	Transistor output 30 V DC 100 mA/30 V DC, short circuit protected 10 Hz to 16 kHz 1 Hz 0.2%

Product compliance

UL, cUL, CE, C-Tick and GOST R approvals

Environmental limits

Degree of protection	IP20 / optional NEMA 1 enclosure
Ambient temperature	-10 to 40 °C (14 to 104 °F), no frost allowed 50 °C (122 °F) with 10% derating
Relative humidity	Lower than 95% (without condensation)

For more information see technical catalogue
 ABB general machinery drives (3AFE68596106).

Find your nearest contact at

efesotomasyon.com

www.abb.com/drivespartners