



# *GE Fanuc Automation*

---

## *Programmable Control Products*

### *IC697VSC096 Single-Board Celeron<sup>®</sup> Processor-Based VMEbus CPU*

#### *User's Manual*

GFK-2055

514-000431-000 A

December 2001

## *Warnings, Cautions, and Notes as Used in this Publication*

### Warning

**Warning notices are used in this publication to emphasize that hazardous voltages, currents, temperatures, or other conditions that could cause personal injury exist in this equipment or may be associated with its use.**

**In situations where inattention could cause either personal injury or damage to equipment, a Warning notice is used.**

### Caution

**Caution notices are used where equipment might be damaged if care is not taken.**

### Note

Notes merely call attention to information that is especially significant to understanding and operating the equipment.

This document is based on information available at the time of its publication. While efforts have been made to be accurate, the information contained herein does not purport to cover all details or variations in hardware or software, nor to provide for every possible contingency in connection with installation, operation, or maintenance. Features may be described herein which are not present in all hardware and software systems. GE Fanuc Automation assumes no obligation of notice to holders of this document with respect to changes subsequently made.

GE Fanuc Automation makes no representation or warranty, expressed, implied, or statutory with respect to, and assumes no responsibility for the accuracy, completeness, sufficiency, or usefulness of the information contained herein. No warranties of merchantability or fitness for purpose shall apply.

The following are trademarks of GE Fanuc Automation North America, Inc.

|                   |             |             |              |
|-------------------|-------------|-------------|--------------|
| Alarm Master      | Genius      | PROMACRO    | Series Six   |
| CIMPLICITY        | Helpmate    | PowerMotion | Series Three |
| CIMPLICITY 90-ADS | Logicmaster | PowerTRAC   | VersaMax     |
| CIMSTAR           | Modelmaster | Series 90   | VersaPro     |
| Field Control     | Motion Mate | Series Five | VuMaster     |
| Genet             | ProLoop     | Series One  | Workmaster   |

# Contents

---

|            |  |            |
|------------|--|------------|
| Chapter 1  | <b>Introduction, Description, and Specifications .....</b> | <b>1-1</b> |
|            | Reference Material and Other GE Fanuc Manuals.....         | 1-1        |
|            | Introduction.....  | 1-3        |
|            | VMEbus Features.....                                       | 1-6        |
|            | VMEbus CPU Product Options.....                            | 1-8        |
|            | Notation and Terminology .....                             | 1-9        |
|            | Safety Summary .....                                       | 1-10       |
| Chapter 2  | <b>Configuration and Installation.....</b>                 | <b>2-1</b> |
|            | Hardware Setup.....  | 2-2        |
|            | Installation.....  | 2-6        |
| Chapter 3  | <b>PC/AT Functions.....</b>                                | <b>3-1</b> |
|            | CPU Socket .....   | 3-2        |
|            | Physical Memory .....                                      | 3-3        |
|            | Memory and Port Maps.....                                  | 3-4        |
|            | PC/AT Interrupts.....                                      | 3-7        |
|            | PCI Interrupts.....  | 3-10       |
|            | I/O Ports .....  | 3-11       |
|            | Video Graphics Adapter.....                                | 3-12       |
|            | Ethernet Controller.....                                   | 3-13       |
| Chapter 4  | <b>Embedded PC/RTOS Features .....</b>                     | <b>4-1</b> |
|            | Timers .....   | 4-2        |
|            | Flash Disk .....   | 4-10       |
|            | Watchdog Timer .....                                       | 4-13       |
|            | Battery Backed SRAM.....                                   | 4-19       |
| Chapter 5  | <b>Maintenance.....</b>                                    | <b>5-1</b> |
|            | Maintenance .....  | 5-1        |
| Appendix A | <b>Connector Pinouts.....</b>                              | <b>A-1</b> |
|            | Ethernet Connector Pinout .....                            | A-3        |
|            | Video Connector Pinout .....                               | A-4        |
|            | Serial Connector Pinout .....                              | A-5        |
|            | Keyboard/Mouse Connector Pinout .....                      | A-6        |
|            | VMEbus Connector Pinout .....                              | A-7        |
| Appendix B | <b>System Driver Software.....</b>                         | <b>B-1</b> |
|            | Windows 95 .....   | B-2        |
|            | Windows NT (Version 4.0).....                              | B-4        |

# Contents

---

|            |  |            |
|------------|--|------------|
| Appendix C | <b>Phoenix BIOS .....</b>                                    | <b>C-1</b> |
|            | Main Menu .....  | C-2        |
|            | Advanced Menu .....  | C-7        |
|            | Security .....   | C-11       |
|            | Power .....  | C-12       |
|            | Boot Menu.....   | C-13       |
|            | Exit Menu.....   | C-14       |
| Appendix D | <b>Device Configuration: I/O and Interrupt Control .....</b> | <b>D-1</b> |
|            | BIOS Operations .....  | D-2        |
|            | Device Address Definition .....                              | D-6        |
|            | Device Interrupt Definition .....                            | D-8        |
| Appendix E | <b>Sample C Software.....</b>                                | <b>E-1</b> |
|            | Directory CPU.....   | E-2        |
|            | Directory SRAM .....   | E-31       |
|            | Directory Timers .....                                       | E-33       |
|            | Directory WATCHDOG .....                                     | E-39       |

*Chapter*

*1*

*Introduction, Description, and Specifications*

---

---

This manual describes installation and operation of the IC697VSC096A Single Board Celeron Processor-Based VMEbus CPU.

## Introduction

The VMEbus CPU is a complete IBM PC/AT-compatible Celeron processor-based computer with the additional benefits of single Eurocard construction and full compatibility with the VMEbus Specification Rev. C.1. The VMEbus CPU, with advanced VMEbus interface and RAM that is dual-ported to the VMEbus, is ideal for multiprocessor applications.

The single CPU board functions as a standard PC/AT, executing a PC/AT-type power-on self-test, then boots up MS-DOS, Windows 95, Windows NT, or any other PC/AT-compatible operating system. The PC/AT mode of the VMEbus CPU is discussed in Chapter 3 of this manual.

The VMEbus CPU also operates as a VMEbus controller and interacts with other VMEbus modules via the on-board PCI-to-VMEbus bridge and the Endian conversion hardware.

The VMEbus CPU may be accessed as a VMEbus slave board. The VMEbus functions are available by programming the VMEbus CPU's PCI-to-VMEbus bridge according to the references defined in this volume and/or in the second volume dedicated to the optional PCI-to-VMEbus interface board titled: *Tundra Universe II™-Based VMEbus Interface User's Manual* (Document No. GFK-2122).

The VMEbus CPU also provides capabilities beyond the features of a typical PC/AT-compatible CPU including general-purpose timers, a programmable watchdog timer, a bootable flash disk system, and nonvolatile, battery-backed SRAM. These features make the unit ideal for embedded applications. These nonstandard PC/AT functions are discussed in Chapter 4 of this manual. The VMEbus CPU performs all the functions of a standard IBM PC/AT motherboard with the following features:

- Single-slot VMEbus 6U size
- Includes a high-performance Intel Celeron processor
- Up to 32 Mbyte of Synchronous DRAM
- 64-bit AGP SVGA video graphics accelerator
  - 2 Mbyte SGRAM Video Memory
  - Resolutions up to 1,280x1024x256 colors
- Battery-backed clock/calendar
- Front panel reset switch and miniature speaker
- On-board port for a keyboard and mouse, Ultra-IDE hard drive, floppy drive, Ethernet, video, dual serial
- Front panel "vital sign" indicators (power, Ultra-IDE hard drive activity, VMEbus SYSFAIL, and Ethernet status)
- Three general-purpose programmable 16-bit timers
- Software-controlled watchdog timer
  - Up to 96 Mbyte of bootable flash on secondary IDE
- 32 Kbyte of battery-backed SRAM
- PMC, PC-MIP

The VMEbus CPU supports standard PC/AT I/O features such as those listed in Table 1-1 below. Figure 1-1 on page 1-5 shows a block diagram of the VMEbus CPU emphasizing the I/O features including the PCI-to-VMEbus bridge.

**Table 1-1: PC/AT I/O Features**

| <b>I/O Feature</b>   | <b>ID</b>         | <b>Physical Access</b>  |
|--|-------------------|---|
| Two Serial Ports<br>(16550-Compatible RS-232C)                               | COM1<br>COM2      | Front Panel,<br>Dual Micro-D 9-Pin  |
| AT-Style Keyboard/Mouse<br>Controller with a PS/2-Style<br>Adapter           | M/K               | Front Panel PS/2-Style Connector,<br>Mini-DIN Circular (female)<br>Adapter “Y” Cable Supplied |
| Super VGA Video Controller<br>with 2 Mbyte SGRAM                             | SVGA              | Front Panel DB15HD<br>High Density (female)   |
| Ethernet, 10BaseT, 100BaseTx,<br>Novell NE-2000 Compatible                   | LAN               | Front Panel RJ45  |
| Floppy Disk Controller<br>(two drives maximum)                               | Drives A, B       | P2  |
| Ultra IDE Fixed Disk Controller<br>(two drives maximum)                      | Drives C, D       | P2  |
| Hardware Reset   | RST               | Front Panel Push-Button   |
| IBM/PC Sound   |                   | Front Panel Speaker Port  |
| Power Status, Hard Drive<br>Activity, VMEbus SYSFAIL, and<br>Ethernet Status | LED<br>Indicators | Front Panel   |

Figure 1-1: VMEbus CPU Block Diagram

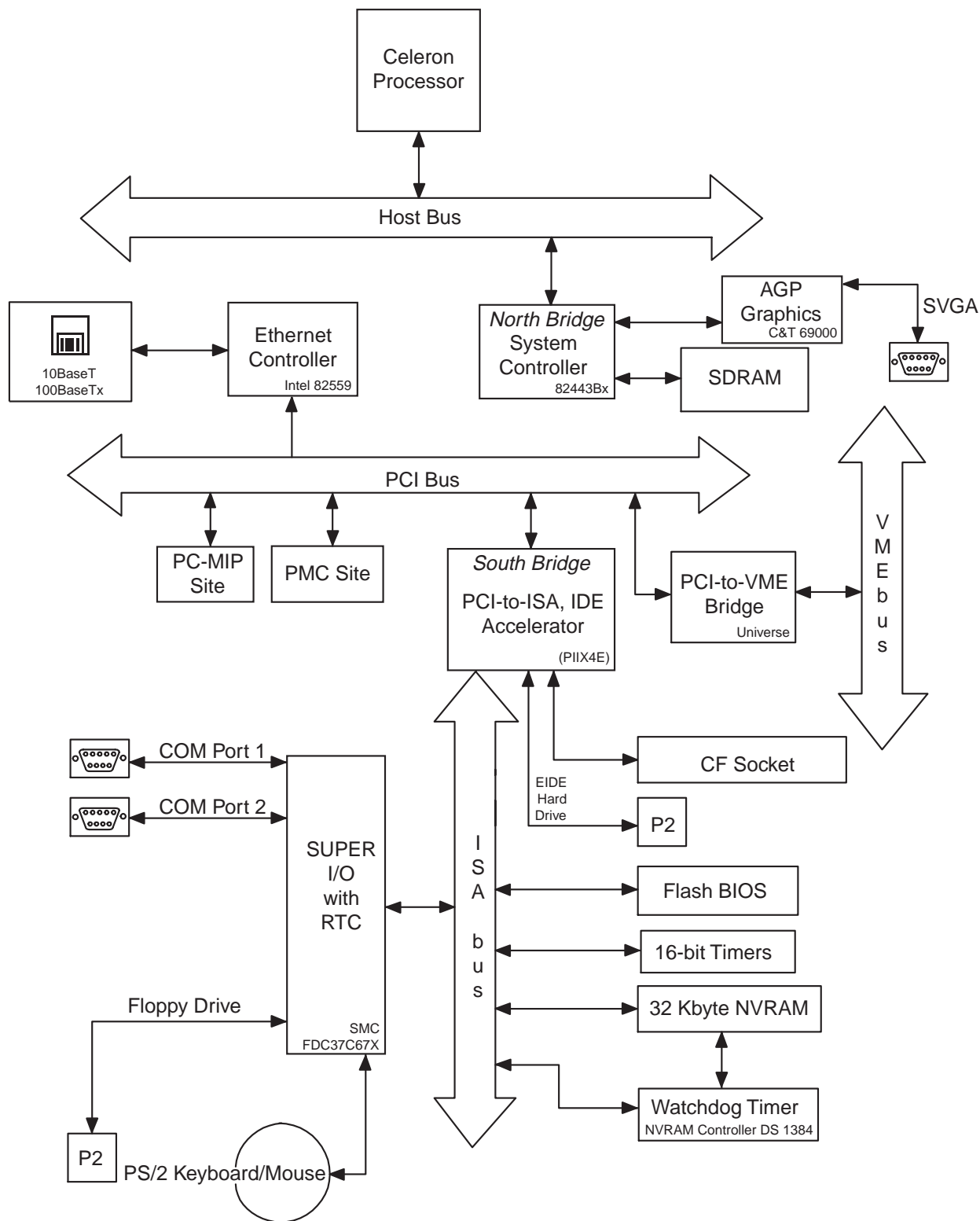

---

## VMEbus Features

In addition to its PC/AT functions, the VMEbus CPU has the following VMEbus features:

- Single-slot, 6U height VMEbus board
- Complete six-line Address Modifier (AM-Code) programmability
- VME data interface with separate hardware byte/word swapping for master and slave accesses
- Support for VME64 multiplexed MBLT 64-bit VMEbus block transfers  
User-configured interrupter
- User-configured interrupt handler
- System Controller mode with programmable VMEbus arbiter (PRI, SGL, and RRS modes are supported)
- VMEbus BERR\* bus error timer (software programmable)
- Slave access from the VMEbus to local RAM and mailbox registers
- Full-featured programmable VMEbus requester (ROR, RWD, and BCAP modes are supported)
- System Controller autodetection
- Complete VMEbus master access through five separate Protected-mode memory windows

Figure 1-2 on page 1-7 illustrates the VMEbus CPU functions in a typical VMEbus system. The VMEbus CPU is a versatile single-board solution for VMEbus control with familiar PC/AT operation.

The VMEbus CPU VMEbus interface is provided by the PCI-to-VMEbus bridge built around the Tundra Semiconductor Corporation Universe II VMEbus interface chip. The Universe II provides a reliable high-performance 64-bit VMEbus-to-PCI interface in one design. The functions and programming of the Universe-based VMEbus interface are addressed in detail in a separate associated manual titled: *Tundra Universe II Based VMEbus Interface User's Manual*.

Figure 1-2: VMEbus CPU VMEbus Functions

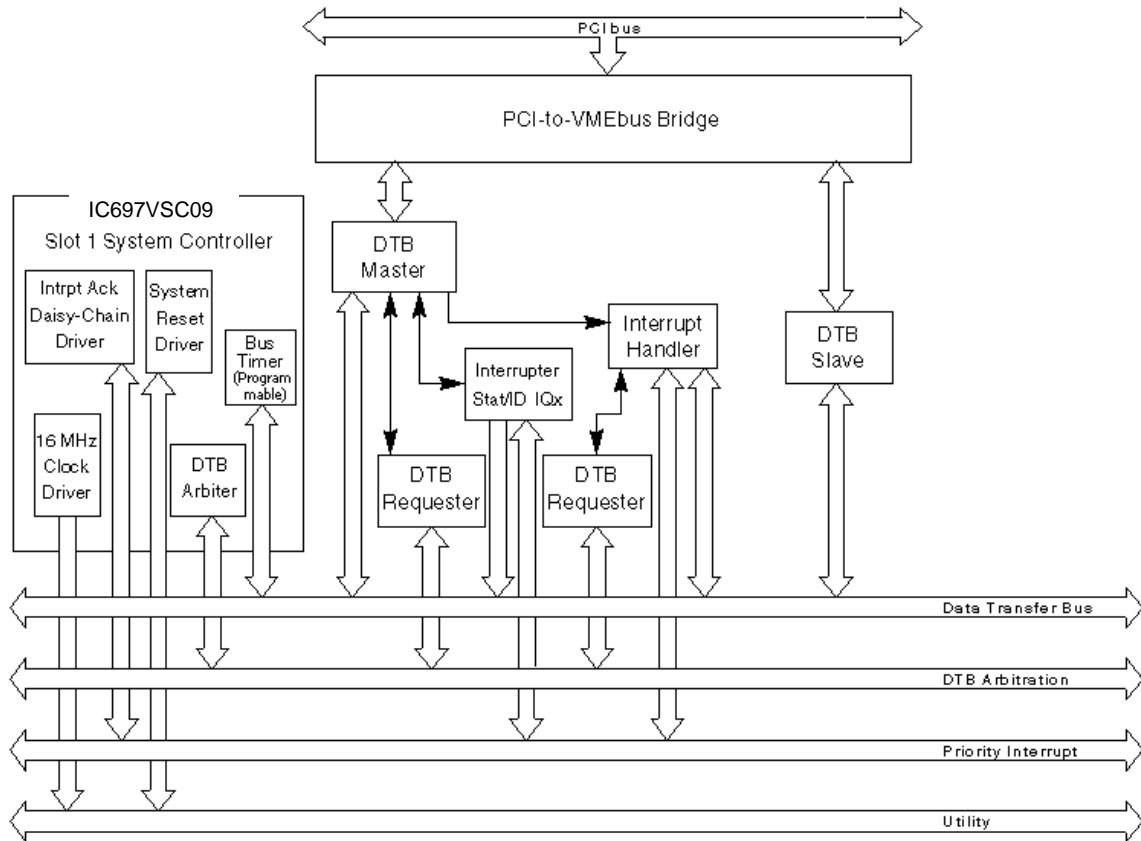

# *VMEbus CPU Product Specifications*

The VMEbus CPU is built around three fundamental hardware configurations. These involve processor performance, the Flash Disk, and SDRAM memory size. These components are subject to change based on emerging technologies and availability of vendor configurations.

Current details for features available on the VMEbus CPU are defined in the device specification sheet available from your GE Fanuc representative.

## Notation and Terminology

This product bridges the traditionally divergent worlds of Intel-based PCs and Motorola-based VMEbus controllers; therefore, some confusion over “conventional” notation and terminology may exist. Every effort has been made to make this manual consistent by adhering to conventions typical for the Motorola/VMEbus world; nevertheless, users in both camps should review the following notes:

Hexadecimal numbers are listed Motorola-style, prefixed with a dollar sign: \$F79, for example. By contrast, this same number would be signified 0F79H according to the Intel convention, or 0xF79 by many programmers. Less common are forms such as F79<sub>h</sub> or the mathematician’s F79<sub>16</sub>.

An 8-bit quantity is termed a “byte,” a 16-bit quantity is termed a “word,” and a 32-bit quantity is termed a “longword.” The Intel convention is similar, although their 32-bit quantity is more often called a “doubleword.”

Motorola programmers should note that Intel processors have an I/O bus that is completely independent from the memory bus. Every effort has been made in the manual to clarify this by referring to registers and logical entities in I/O space by prefixing I/O addresses as such. Thus, a register at “I/O \$140” is not the same as a register at “\$140,” since the latter is on the memory bus while the former is on the I/O bus.

Intel programmers should note that addresses are listed in this manual using a linear, “flat-memory” model rather than the old segment:offset model associated with Intel Real Mode programming. Thus, a ROM chip at a segment:offset address of C000:0 will be listed in this manual as being at address \$C0000. For reference, here are some quick conversion formulas:

Segment:Offset to Linear Address

Linear Address = (Segment × 16) + Offset

Linear Address to Segment:Offset

Segment = ((Linear Address ÷ 65536) – remainder) × 4096

Offset = remainder × 65536

Where *remainder* = the fractional part of (Linear Address ÷ 65536)

Note that there are many possible segment:offset addresses for a single location. The formula above will provide a unique segment:offset address by forcing the segment to an even 64 Kbyte boundary, for example, \$C000, \$E000, etc. When using this formula, make sure to round the offset calculation properly.

---

## *Safety Summary*

### **Warning**

**The following general safety precautions must be observed during all phases of this operation, service, and repair of this product. Failure to comply with these precautions or with specific warnings elsewhere in this manual violates safety standards of design, manufacture, and intended use of this product. GE Fanuc assumes no liability for the customer's failure to comply with these requirements.**

#### **Ground the System**

To minimize shock hazard, the chassis and system cabinet must be connected to an electrical ground. A three-conductor AC power cable should be used. The power cable must either be plugged into an approved three-contact electrical outlet or used with a three-contact to two-contact adapter with the grounding wire (green) firmly connected to an electrical ground (safety ground) at the power outlet.

#### **Do Not Operate in an Explosive Atmosphere**

Do not operate the system in the presence of flammable gases or fumes. Operation of any electrical system in such an environment constitutes a definite safety hazard.

#### **Keep Away from Live Circuits**

Operating personnel must not remove product covers. Component replacement and internal adjustments must be made by qualified maintenance personnel. Do not replace components with power cable connected. Under certain conditions, dangerous voltages may exist even with the power cable removed. To avoid injuries, always disconnect power and discharge circuits before touching them.

#### **Do Not Service or Adjust Alone**

Do not attempt internal service or adjustment unless another person, capable of rendering first aid and resuscitation, is present.

#### **Do Not Substitute Parts or Modify System**

Because of the danger of introducing additional hazards, do not install substitute parts or perform any unauthorized modification to the product. Return the product to GE Fanuc for service and repair to ensure that safety features are maintained.

## Reference Material

For the most up-to-date specifications for the VMEbus CPU, please refer to the following document.

### **GE Fanuc specification number GFK-2091**

For information on the Tundra Universe II-based interface available in the VMEbus CPU, please refer to the following document:

### **IC697VSC096 Tundra Universe II™-Based VMEbus Interface Product Manual**

GE Fanuc Doc. No. GFK-2122

VMEbus Interface Components Manual

Tundra Semiconductor Corporation

603 March Rd.

Kanata, Ontario

Canada, K2K 2M5

(800) 267-7231 (Canada) (613) 592-0714 (International) FAX: (613) 592-1320

Internet: [www.tundra.com](http://www.tundra.com)

For help in using or programming the VMEbus CPU, please refer to the following sources.

### **Celeron Processors and Related Products**

Intel Literature Sales

P.O. Box 7641

Mt. Prospect, IL 60056-7641

(800) 548-4752

Internet: [www.intel.com](http://www.intel.com)

### **Intel 440BX PCIset**

82443BX PCI and Memory Controller (PMC) 82443BX Data Bus Accelerator (DBX)

May 1996, Order Number 290549-001

Intel Corporation

P.O. Box 58119

Santa Clara, CA 95052-8119

(408) 765-8080

Internet: [www.intel.com](http://www.intel.com)

### **PCI Special Interest Group (PCI-SIG)**

5440 SW Westgate Dr., No. 217

Portland, OR 97221

(503) 291-2569 (International)

FAX: (503) 297-1090

Internet: [www.pcisig.com](http://www.pcisig.com)

The VMEbus interrupt and control software library references included for Windows NT are included in the VMEbus Access (VMISFT-9420) software product.

VMIC  
12090 South Memorial Parkway  
Huntsville, AL 35803-3308  
(800) 322-3616  
FAX: (256) 882-0859  
Internet: [www.vmic.com](http://www.vmic.com)

For a detailed description and specification of the VMEbus, please refer to the following document.

**VMEbus Specification Rev. C.1 and The VMEbus Handbook**  
VITA  
VMEbus International Trade Association  
7825 East Gelding Dr., No. 104  
Scottsdale, AZ 85260  
(480) 951-8866  
FAX: (480) 951-0720  
Internet: [www.vita.com](http://www.vita.com)

For useful information related to remote Ethernet booting of the VMEbus CPU, please refer to the following document.

**Microsoft Windows NT Server Resource Kit**  
Microsoft Corporation  
ISBN: 1-57231-344-7  
Internet: [www.microsoft.com](http://www.microsoft.com)

# Chapter 2

## *Configuration and Installation*

---

---

This chapter describes the hardware jumper settings, connector definitions, installation, system setup, and operation of the VMEbus CPU. The PCI-to-VMEbus bridge and the Tundra Universe II-based interface are also included.

This chapter is divided into the following sections:

- Hardware Setup
- Installation

### Caution

**Some of the components assembled on GE Fanuc's products may be sensitive to electrostatic discharge, and damage may occur on boards that are subjected to a high energy electrostatic field. When the board is placed on a bench for configuring, etc., it is suggested that conductive material be inserted under the board to provide a conductive shunt. Unused boards should be stored in the same protective boxes in which they were shipped.**

Any precautions found in the shipping container should be observed. All items should be carefully unpacked and thoroughly inspected for damage that might have occurred during shipment. All claims arising from shipping damage should be filed with the carrier and a complete report sent to GE Fanuc Customer Service together with a request for advice concerning the disposition of the damaged item(s).

## Hardware Setup

### Jumper Settings

The VMEbus CPU is tested for system operation and shipped with factory-installed header jumpers. The physical location of the jumpers and connectors for the single board CPU are illustrated in Figure 2-1 on page 2-3. The definitions of the CPU board jumpers and connectors are included in Tables 2-1, 2-2, and 2-3 on page 2-4, and Table 2-4 on page 2-5. The Tundra Universe II-based PCI-to-VMEbus Bridge jumper configuration is discussed in Chapter 3.

#### Caution

**All jumpers are factory configured and should not be modified by the user. There are three exceptions: the Password Clear (E4), the Programmable Timer Clock Select (E8), the Watchdog Timer (E8) and the NVRAM Battery Power (E8).**

Modifying any other jumper will void the Warranty and may damage the unit. The default jumper condition of the VMEbus CPU is expressed in Tables 2-1, 2-2, and 2-3 on page 2-4, and Tables 2-4, 2-5, 2-6, and 2-7 on page 2-5 with bold text in the table cells.

Figure 2-1: VMEbus CPU Board, I/O Port, and Jumper Locations

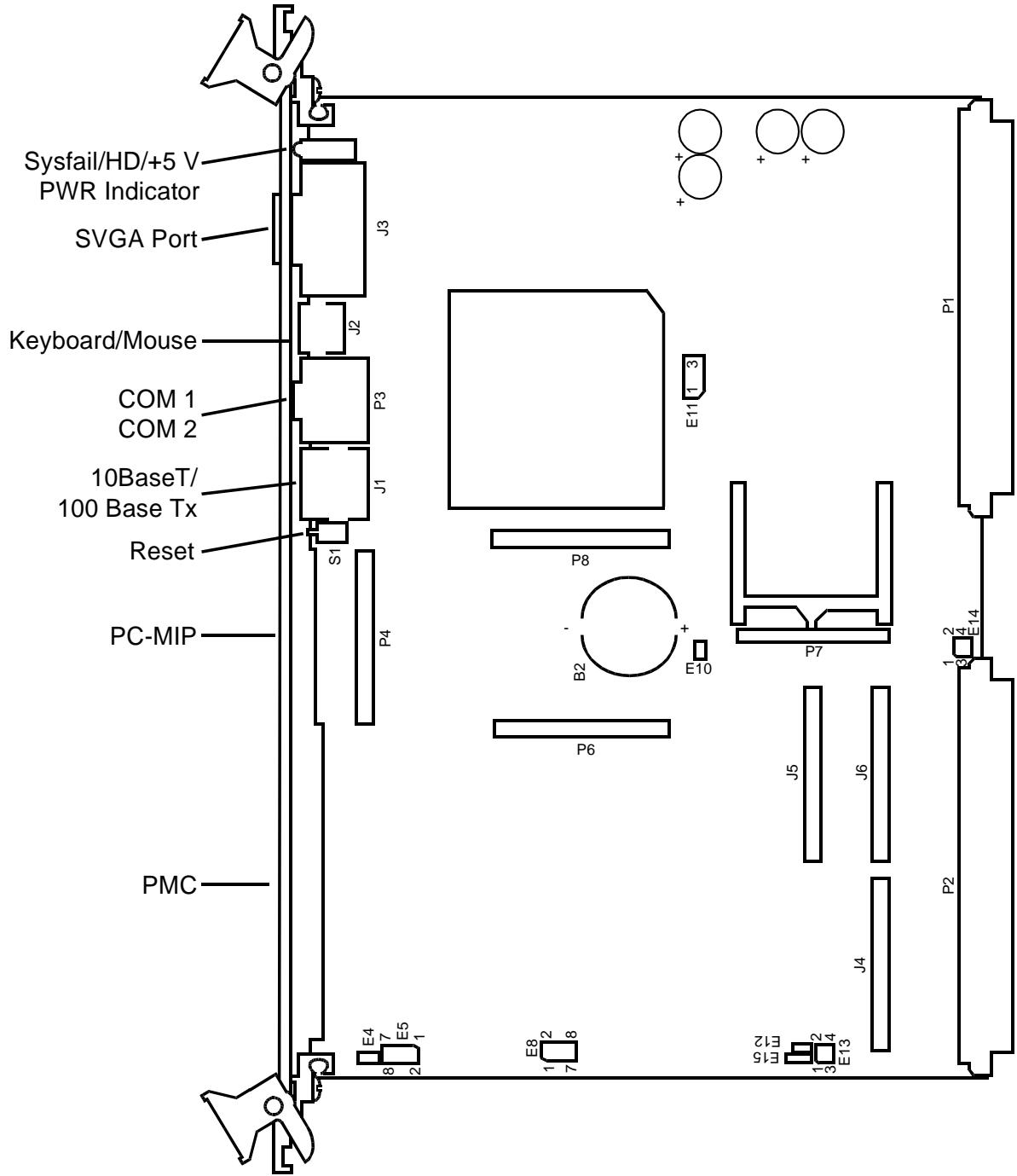

Table 2-1: CPU Board Connectors

| Connector  | Function                        |
|------------|---------------------------------|
| P3         | COM1/COM2                       |
| J3         | Video Connector                 |
| J1         | Ethernet Connector              |
| J2         | PS/2 Keyboard/Mouse Connector   |
| E11        | Fan Connector                   |
| P1, P2     | VME Connectors                  |
| J4, J5, J6 | PMC PCI Expansion Connectors    |
| P4, P6, P8 | PC-MIP PCI Expansion Connectors |

Jumper E8 below serves several functions on the VMEbus CPU. These functions are: The Watchdog Timer/NMI, Programmable Timer Clock Select, and the NVRAM Battery Enable.

Table 2-2: Timers and NVRAM Battery Select (User Configurable) - Jumper (E8)

| Select                                    | Jumper Position |
|---|-----------------|
| <b>Watchdog Timer</b>                     |                 |
| RESET                                     | 2-4             |
| NMI                                       | 4-6             |
| No RESET or NMI                           | Out             |
| <b>Programmable Timer Clock Selection</b> |                 |
| 1 Mhz                                     | 1-3             |
| 2 Mhz                                     | 3-5             |
| <b>*NVRAM Battery Power</b>               |                 |
| NVRAM Battery Disabled                    | Out             |
| NVRAM Battery Enabled                     | 7-8             |

\* Enable battery for operation, disable battery for storage

Table 2-3: BIOS Mode Option - Jumper (E15)

| Select                 | Jumper Position |
|------------------------|-----------------|
| Normal                 | 1-2             |
| Boot Block Programming | 2-3             |

### Note

The VMEbus CPU's BIOS has the capability (Default: Disabled) of password protecting casual access to the unit's CMOS set-up screens. The Password Clear jumper (E4) allows for a means to clear the password feature, as might be necessary to do in the case of a forgotten password.

## To Clear the CMOS:

1. Turn off power to the unit.
2. Install a jumper at E4.
3. Power up the unit.
4. Turn off the power to the unit and remove the jumper from E4.

When power is re-applied to the unit, the CMOS will be cleared.

**Table 2-4: Password Clear (User Configurable) - Jumper (E4)**

|                     | <b>Jumper Position</b> |
|---------------------|------------------------|
| <b>Normal</b>       | <b>Out</b>             |
| Clear CMOS/Password | In                     |

**Table 2-5: CPU Clock/Bus Multiple - Jumper Blocks (E5)**

| <b>CPU</b>      | <b>Jumper Position</b> |
|-----------------|------------------------|
| Celeron 300 MHz | 3-4, 7-8               |

**Table 2-6: CMOS Battery Enable - Jumper (E10)**

|                             | <b>Jumper Position</b> |
|-----------------------------|------------------------|
| CMOS Battery Disabled       | Out                    |
| <b>CMOS Battery Enabled</b> | <b>In</b>              |

**Table 2-7: VME Interface Jumper Factory-installed Settings**

| <b>Jumper</b> | <b>Function</b>  | <b>Jumper Position</b>            |
|---------------|--|-----------------------------------|
| E13, 1-3      | Installed – Universe Memory Mapped   | Installed (should not be removed) |
| E13, 2-4      | Installed – SYSFAIL Not Asserted Upon Reset<br>Removed - SYSFAIL Asserted Upon Reset | Installed                         |
| E14, 1-3      | Installed – Drives VMEbus SYSRESET<br>Removed - Does not drive                       | Installed                         |
| E14, 2-4      | Installed – Receives VMEbus SYSRESET<br>Removed - Does not receive                   | Installed                         |

## Installation

The VMEbus CPU conforms to the VMEbus physical specification for a 6U dual Eurocard (dual height). It can be plugged directly into any standard chassis accepting this type of board.

### Caution

**Do not install or remove the board while power is applied.**

The following steps describe the GE Fanuc-recommended method for VMEbus CPU installation and power-up:

1. Make sure power to the equipment is off.
2. Choose chassis slot. The VMEbus CPU *must* be attached to a dual P1/P2 VMEbus backplane.

If the VMEbus CPU is to be the VMEbus system controller, choose the first VMEbus slot. If some other board is the VMEbus system controller, choose any slot except slot one. The VMEbus CPU does not require jumpers for enabling/disabling the system controller function.

### Note

**The VMEbus CPU requires forced air cooling. It is advisable to install blank panels over any exposed VMEbus slots. This will allow for better air flow over the VMEbus CPU board. For 20-slot VME configurations, three 100 CFM fans are recommended.**

3. Insert the VMEbus CPU and its attached expansion modules into the chosen VMEbus chassis slot (expansion modules should fill the slots immediately adjacent to the VMEbus CPU). While ensuring that the boards are properly aligned and oriented in the supporting board guides, slide the boards smoothly forward against the mating connector until firmly seated.
4. Connect all needed peripherals to the front panel. Each connector is clearly labeled on the front panel, and detailed pinouts are in Appendix A. Minimally, a keyboard and a monitor are required if the user has not previously configured the system.
5. Apply power to the system. Several messages are displayed, including names, versions and copyright dates for the various BIOS modules on the VMEbus CPU.
6. The VMEbus CPU features a Flash Disk resident on the board. Refer to Chapter 4 for setup details.
7. If an external drive module is installed, the BIOS Setup program must be run to configure the drive types. See Appendix C to properly configure the system.
8. If a drive module is present, install the operating system according to the manufacturer's instructions.

See Appendix B for instructions on installing VMEbus CPU peripheral driver software during operating system installation.

# BIOS Setup

The VMEbus CPU has an on-board BIOS Setup program that controls many configuration settings. These settings are saved in a special nonvolatile, battery-backed memory chip and are collectively referred to as the board's "CMOS configuration." The CMOS configuration controls many details concerning the behavior of the hardware from the moment power is applied.

The VMEbus CPU is shipped from the factory with no hard drives configured in CMOS. The BIOS Setup program must be run to configure the specific drives attached.

Details of the VMEbus CPU BIOS setup program are included in Appendix C.

# Front Panel Connectors

The front panel connections, including connector pinouts and orientation, for the VMEbus CPU are defined in detail in Appendix A.

# PMC Expansion Site Connectors

The VMEbus CPU supplies PMC and PC-MIP expansion site connectors for adding a PMC and/or PC-MIP expansion board. This expansion capability allows third-party devices to be used with the VMEbus CPU, as shown in Figure 2-2 below.

Figure 2-2: PCI Expansion Site

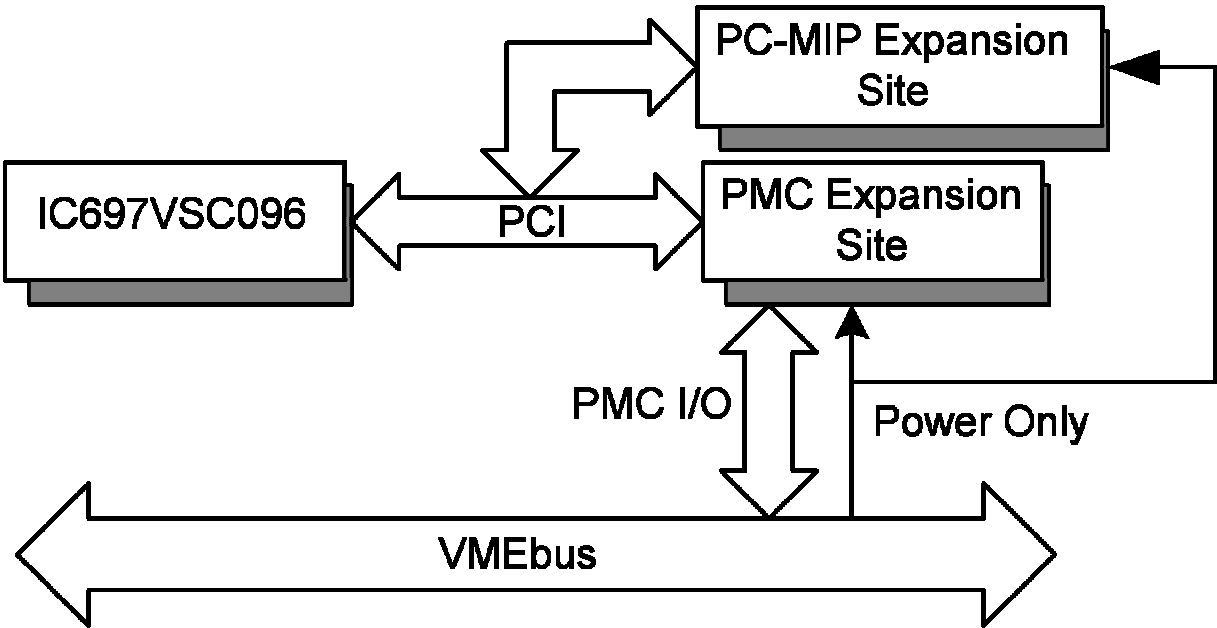

# LED Definition

Figure 2-3: LED Position on the Front Panel

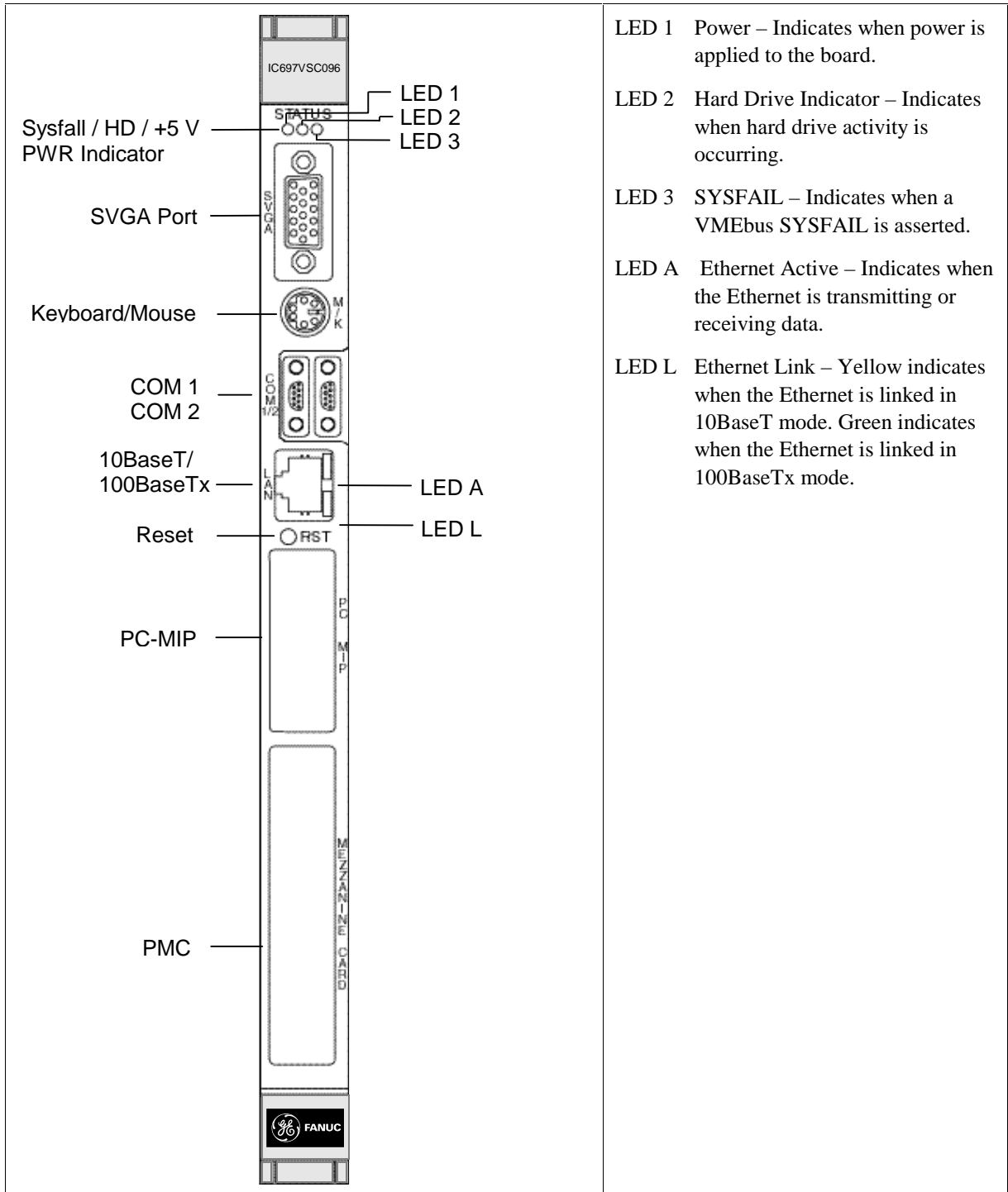

- LED 1 Power – Indicates when power is applied to the board.
- LED 2 Hard Drive Indicator – Indicates when hard drive activity is occurring.
- LED 3 SYSFAIL – Indicates when a VMEbus SYSFAIL is asserted.
- LED A Ethernet Active – Indicates when the Ethernet is transmitting or receiving data.
- LED L Ethernet Link – Yellow indicates when the Ethernet is linked in 10BaseT mode. Green indicates when the Ethernet is linked in 100BaseTx mode.

# Chapter 3

## *PC/AT Functions*

---

---

The VMEbus CPU provides a complete IBM PC/AT-compatible Celeron processor-based computer. The design includes a high-speed microprocessor with current technology memory. Reference the GE Fanuc product specifications for available component options.

Because the design is PC/AT compatible, it retains standard PC memory and I/O maps along with standard interrupt architecture. Furthermore, the VMEbus CPU includes a PCI-compatible video adapter and Ethernet controller.

This chapter describes in detail the PC/AT functions of the VMEbus CPU, and is divided into the following sections:

- CPU Socket
- Physical Memory
- Memory and Port Maps
- PC/AT Interrupts
- PCI Interrupts
- I/O Ports
- Video Graphics Adapter
- Ethernet Controller

## *CPU Socket*

The VMEbus CPU socket is factory populated with a high-speed Celeron processor.

## *Physical Memory*

The VMEbus CPU provides Synchronous DRAM (SDRAM) as on-board system memory. Memory can be accessed as bytes, words, or longwords.

All RAM on the VMEbus CPU is dual-ported to the VMEbus through the

PCI-to-VME bridge. The memory is addressable by the local processor, as well as the VMEbus slave interface by another VMEbus master. Caution must be used when sharing memory between the local processor and the VMEbus to prevent a VMEbus master from overwriting the local processor's operating system.

### **Note**

**When using the Configure utility of I/O Works Access with Windows NT 4.0 to configure RAM, do not request more than 25 percent of the physical RAM. Exceeding the 25 percent limit may result in a known Windows NT bug causing unpredictable behavior during the Windows NT boot sequence and require the use of an emergency repair disk to restore the computer. The bug is present in Windows NT 4.0 service pack level 3. It is recommended that an emergency repair disk be kept up-to-date and easily accessible.**

The VMEbus CPU includes the system BIOS, video BIOS, and LANWorks BIOS in a single flash memory device.

The VMEbus CPU memory includes 32 Kbyte of battery-backed SRAM addressed at \$D8000 to \$DFFFF. All but the first 24 bytes are accessible. Bytes \$D8000 - \$D800D are used by the Watchdog controller and include the System Command Register (COMM), the VME BERR Address Register (VBAR), the VME BERR Address Modifier Register (VBAMR), and the Board ID Register (BID). The System registers are explained in Volume II of this manual set. The battery-backed SRAM can be accessed by the CPU at anytime, and can be used to store system data that must not be lost during power-off conditions (Bytes \$D800E - \$D8017 are the System Registers).

## Memory and Port Maps

### Memory Map

The memory map for the VMEbus CPU is shown in Table 3-1 below.

#### Note

The 32 Mbytes of SDRAM do not fill the entire space reserved for On-Board Extended Memory.

**Table 3-1: VMEbus CPU, Universe II-Based Interface Memory Address Map**

| Mode           | Memory Address Range      | Size                    | Description                                 |
|----------------|---------------------------|-------------------------|---|
| PROTECTED MODE | \$FFFF 0000 - \$FFFF FFFF | 64 Kbyte                | ROM BIOS Image                              |
|                | \$0400 0000 - \$FFFE FFFF | 3.9 Gbyte               | Unused *                                    |
|                | \$0010 0000 - \$0FFF FFFF | 32 Mbyte                | Reserved for **<br>On-Board Extended Memory |
| REAL MODE      | \$E0000 - \$FFFFFF        | 128 Kbyte               | ROM BIOS                                    |
|                | \$D8018 - \$DFFFF         | 32 Kbyte minus 24 bytes | Battery-Backed SRAM                         |
|                | \$D8016 - \$D8017         | 2 bytes                 | Board ID Register (BID) (0x7698)            |
|                | \$D8014 - \$D8015         | 2 bytes                 | VME BERR Address Modifier Register (VBAMR)  |
|                | \$D8010 - \$D8013         | 4 bytes                 | VME BERR Address Register (VBAR)            |
|                | \$D800E - \$D800F         | 2 bytes                 | System Command Register (COMM)              |
|                | \$D8000 - \$D800D         | 14 bytes                | RTC/Watchdog Timer Control Registers        |
|                | \$C8000 - \$D7FFF         | 64 Kbyte                | LANWorks BIOS                               |
|                | \$C0000 - \$C7FFF         | 32 Kbyte                | Video ROM                                   |
|                | \$A0000 - \$BFFFF         | 128 Kbyte               | Video RAM                                   |
|                | \$00000 - \$9FFFF         | 640 Kbyte               | User RAM/DOS RAM                            |

\* This space can be used to set up protected mode PCI-to-VMEbus windows (also referred to as PCI slave images).

\*\* This space can be allocated as shared memory (for example, between the Celeron processor-based CPU and VMEbus Master. Note, that if a PMC board is loaded, the expansion BIOS may be placed in this area.

## I/O Port Map

The Celeron processor-based CPU includes special input/output instructions that access I/O peripherals residing in I/O addressing space (separate and distinct from memory addressing space). Locations in I/O address space are referred to as ports. When the CPU decodes and executes an I/O instruction, it produces a 16-bit I/O address on lines A00 to A15 and identifies the I/O cycle to the processor's M/IO control line. Thus, the CPU includes an independent 64Kbyte I/O address space, which is accessible as bytes, words, or longwords.

Standard PC/AT hardware circuitry reserves only 1,024 bytes of I/O addressing space from I/O \$000 to \$3FF for peripherals. All standard PC I/O peripherals such as serial and parallel ports, hard and floppy drive controllers, video system, real-time clock, system timers, and interrupt controllers are addressed in this region of I/O space. The BIOS initializes and configures all these registers properly; adjusting these I/O ports directly is not normally necessary.

The assigned and user-available I/O addresses are summarized in Table 3-2 below.

**Table 3-2: VMEbus CPU I/O Address Map**

| I/O Address Range | Size in Bytes | HW Device      | PC/AT Function   |
|-------------------|---------------|----------------|--|
| \$000 - \$00F     | 16            |                | DMA Controller 1<br>(Intel 8237A Compatible)                         |
| \$010 - \$01F     | 16            |                | Reserved   |
| \$020 - \$021     | 2             |                | Master Interrupt Controller<br>(Intel 8259A Compatible)              |
| \$022 - \$03F     | 30            |                | Reserved   |
| \$040 - \$043     | 4             |                | Programmable Timer<br>(Intel 8254 Compatible)                        |
| \$044 - \$05F     | 30            |                | Reserved   |
| \$060 - \$064     | 5             |                | Keyboard, Speaker, Eqpt.<br>Configuration<br>(Intel 8042 Compatible) |
| \$065 - \$06F     | 11            |                | Reserved   |
| \$070 - \$071     | 2             |                | Real-Time Clock, NMI Mask  |
| \$072 - \$07F     | 14            |                | Reserved   |
| \$080 - \$08F     | 16            |                | DMA Page Registers   |
| \$090 - \$091     | 2             |                | Reserved   |
| \$092             | 1             |                | Alt. Gate A20/Fast Reset<br>Register                                 |
| \$093             | 1             |                | Reserved   |
| \$094             | 1             | Super VGA Chip | POS102 Access Control<br>Register                                    |
| \$095 - \$09F     | 11            |                | Reserved   |
| \$0A0 - \$0A1     | 2             |                | Slave Interrupt Controller<br>(Intel 8259A Compatible)               |
| \$0A2 - \$0BF     | 30            |                | Reserved   |
| \$0C0 - \$0DF     | 32            |                | DMA Controller 2<br>(Intel 8237A Compatible)                         |

| <b>I/O Address Range</b> | <b>Size in Bytes</b> | <b>HW Device</b> | <b>PC/AT Function</b>                 |
|--------------------------|----------------------|------------------|---------------------------------------|
| \$0E0 - \$16F            | 142                  |                  | Reserved                              |
| \$170 - \$177            | 8                    | PIIX4E           | Secondary Hard Disk Controller        |
| \$178 - \$1EF            | 120                  |                  | User I/O                              |
| \$1F0 - \$1F7            | 8                    | PIIX4E           | Primary Hard Disk Controller          |
| \$1F8 - \$277            | 128                  |                  | User I/O                              |
| \$278 - \$27F            | 8                    | Super I/O Chip*  | LPT2 Parallel I/O*                    |
| \$280 - \$2E7            | 104                  |                  | Reserved                              |
| \$2E8 - \$2EE            | 7                    | UART*            | COM4 Serial I/O*                      |
| \$2EF - \$2F7            | 9                    |                  | User I/O                              |
| \$2F8 - \$2FE            | 7                    | Super-I/O Chip   | COM2 Serial I/O<br>(16550 Compatible) |
| \$2FF - \$36F            | 113                  |                  | Reserved                              |
| \$370 - \$377            | 8                    | Super-I/O Chip   | Secondary Floppy Disk<br>Controller   |
| \$378 - \$37F            | 8                    | Super-I/O Chip   | LPT1 Parallel I/O                     |
| \$380 - \$3E7            | 108                  |                  | Reserved                              |
| \$3E8 - \$3EE            | 7                    | UART*            | COM3 Serial I/O*                      |
| \$3F0 - \$3F7            | 8                    | Super-I/O Chip   | Primary Floppy Disk Controller        |
| \$3F8 - \$3FE            | 7                    | Super-I/O Chip   | COM1 Serial I/O<br>(16550 Compatible) |
| \$3FF - \$4FF            |                      |                  | Reserved                              |
| \$500 - \$503            | 4                    | 82C54 Timer      | Programmable Internal Timer           |
| \$504 - \$CFF            |                      |                  | Reserved                              |

\* While these I/O ports are reserved for the listed functions, they are not implemented on the VMEbus CPU. They are listed here to make the user aware of the standard PC/AT usage of these ports.

## PC/AT Interrupts

In addition to an I/O port address, an I/O device has a separate hardware interrupt line assignment. Assigned to each interrupt line is a corresponding interrupt vector in the 256-vector interrupt table at \$00000 to \$003FF in memory. The 16 maskable interrupts and the single Non-Maskable Interrupt (NMI) are listed in Table 3-3 below, along with their functions. Table 3-4 on page 3-8 details the vectors in the interrupt vector table. The interrupt number in HEX and decimal are also defined for real and protected mode in Table 3-4 on page 3-8.

The interrupt hardware implementation on the VMEbus CPU is standard for computers built around the PC/AT architecture, which evolved from the IBM PC/XT. In the IBM PC/XT computers, only eight interrupt request lines exist, numbered from IRQ0 to IRQ7 at the PIC. The IBM PC/AT computer added eight more IRQx lines, numbered IRQ8 to IRQ15, by cascading a second slave PIC into the original master PIC. IRQ2 at the master PIC was committed as the cascade input from the slave PIC. This architecture is represented in Figure 3-1 on page 3-11.

To maintain backward compatibility with PC/XT systems, IBM chose to use the new IRQ9 input on the slave PIC to operate as the old IRQ2 interrupt line on the PC/XT Expansion Bus. Thus, in AT systems, the IRQ9 interrupt line connects to the old IRQ2 pin (pin B4) on the AT Expansion Bus (or ISA bus).

**Table 3-3: PC/AT Hardware Interrupt Line Assignments**

| IRQ | AT Function                                      | Comments                           |
|-----|--|------------------------------------|
| NMI | Parity Errors<br>(Must be enabled in BIOS Setup) | Used by the CPU's VMEbus Interface |
| 0   | System Timer                                     | Set by BIOS Setup                  |
| 1   | Keyboard   | Set by BIOS Setup                  |
| 2   | Duplexed to IRQ9                                 |                                    |
| 3   | COM2/COM4  |                                    |
| 4   | COM1/COM3  |                                    |
| 5   | Timer  | Assigned to On-Board Timer         |
| 6   | Floppy Controller                                |                                    |
| 7   | LPT1   | Not Available                      |
| 8   | Real-Time Clock                                  |                                    |
| 9   | Old IRQ2   | Determined by BIOS                 |
| 10  | Not Assigned                                     | Determined by BIOS                 |
| 11  | Not Assigned                                     | Determined by BIOS                 |
| 12  | Mouse  |                                    |
| 13  | Math Coprocessor                                 |                                    |
| 14  | AT Hard Drive                                    |                                    |
| 15  | Flash Drive                                      |                                    |

Table 3-4: PC/AT Interrupt Vector Table

| Interrupt No. |     | IRQ Line | Real Mode                                 | Protected Mode                                       |
|---------------|-----|----------|---|--|
| HEX           | DEC |          |   |  |
| 00            | 0   |          | Divide Error                              | Same as Real Mode                                    |
| 01            | 1   |          | Debug Single Step                         | Same as Real Mode                                    |
| 02            | 2   | NMI      | Memory Parity Error,<br>VMEbus Interrupts | Same as Real Mode (Must be<br>enabled in BIOS Setup) |
| 03            | 3   |          | Debug Breakpoint                          | Same as Real Mode                                    |
| 04            | 4   |          | ALU Overflow                              | Same as Real Mode                                    |
| 05            | 5   |          | Print Screen                              | Array Bounds Check                                   |
| 06            | 6   |          |   | Invalid OpCode                                       |
| 07            | 7   |          |   | Device Not Available                                 |
| 08            | 8   | IRQ0     | Timer Tick                                | Double Exception Detected                            |
| 09            | 9   | IRQ1     | Keyboard Input                            | Coprocessor Segment Overrun                          |
| 0A            | 10  | IRQ2     | BIOS Reserved                             | Invalid Task State Segment                           |
| 0B            | 11  | IRQ3     | COM2 Serial I/O                           | Segment Not Present                                  |
| 0C            | 12  | IRQ4     | COM1 Serial I/O                           | Stack Segment Overrun                                |
| 0D            | 13  | IRQ5     | Onboard 16bit Timers                      | Same as Real Mode                                    |
| 0E            | 14  | IRQ6     | Floppy Disk Controller                    | Page Fault   |
| 0F            | 15  | IRQ7     | LPT1 Parallel I/O                         | Unassigned   |
| 10            | 16  |          | BIOS Video I/O                            | Coprocessor Error                                    |
| 11            | 17  |          | Eqpt Configuration Check                  | Same as Real Mode                                    |
| 12            | 18  |          | Memory Size Check                         | Same as Real Mode                                    |
| 13            | 19  |          | XT Floppy/Hard Drive                      | Same as Real Mode                                    |
| 14            | 20  |          | BIOS Comm I/O                             | Same as Real Mode                                    |
| 15            | 21  |          | BIOS Cassette Tape I/O                    | Same as Real Mode                                    |
| 16            | 22  |          | BIOS Keyboard I/O                         | Same as Real Mode                                    |
| 17            | 23  |          | BIOS Printer I/O                          | Same as Real Mode                                    |
| 18            | 24  |          | ROM BASIC Entry Point                     | Same as Real Mode                                    |
| 19            | 25  |          | Bootstrap Loader                          | Same as Real Mode                                    |
| 1A            | 26  | IRQ8     | Real-Time Clock                           | Same as Real Mode                                    |
| 1B            | 27  |          | Control/Break Handler                     | Same as Real Mode                                    |
| 1C            | 28  |          | Timer Control                             | Same as Real Mode                                    |
| 1D            | 29  |          | Video Parameter Table Pntr                | Same as Real Mode                                    |
| 1E            | 30  |          | Floppy Parm Table Pntr                    | Same as Real Mode                                    |
| 1F            | 31  |          | Video Graphics Table Pntr                 | Same as Real Mode                                    |
| 20            | 32  |          | DOS Terminate Program                     | Same as Real Mode                                    |
| 21            | 33  |          | DOS Function Entry Point                  | Same as Real Mode                                    |
| 22            | 34  |          | DOS Terminate Handler                     | Same as Real Mode                                    |
| 23            | 35  |          | DOS Control/Break<br>Handler              | Same as Real Mode                                    |
| 24            | 36  |          | DOS Critical Error Handler                | Same as Real Mode                                    |
| 25            | 37  |          | DOS Absolute Disk Read                    | Same as Real Mode                                    |
| 26            | 38  |          | DOS Absolute Disk Write                   | Same as Real Mode                                    |

| Interrupt No. |         | IRQ Line | Real Mode                            | Protected Mode    |
|---------------|---------|----------|--------------------------------------|-------------------|
| HEX           | DEC     |          |                                      |                   |
| 27            | 39      |          | DOS Program Terminate, Stay Resident | Same as Real Mode |
| 28            | 40      |          | DOS Keyboard Idle Loop               | Same as Real Mode |
| 29            | 41      |          | DOS CON Dev. Raw Output              | Same as Real Mode |
| 2A            | 42      |          | DOS 3.x+ Network Comm                | Same as Real Mode |
| 2B            | 43      |          | DOS Internal Use                     | Same as Real Mode |
| 2C            | 44      |          | DOS Internal Use                     | Same as Real Mode |
| 2D            | 45      |          | DOS Internal Use                     | Same as Real Mode |
| 2E            | 46      |          | DOS Internal Use                     | Same as Real Mode |
| 2F            | 47      |          | DOS Print Spooler Driver             | Same as Real Mode |
| 30-60         | 48-96   |          | Reserved by DOS                      | Same as Real Mode |
| 61-66         | 97-102  |          | User Available                       | Same as Real Mode |
| 67-70         | 103-112 |          | Reserved by DOS                      | Same as Real Mode |
| 71            | 113     | IRQ9     | Not Assigned                         |                   |
| 72            | 114     | IRQ10    | Not Assigned                         |                   |
| 73            | 115     | IRQ11    | Not Assigned                         |                   |
| 74            | 116     | IRQ12    | Mouse                                |                   |
| 75            | 117     | IRQ13    | Math Coprocessor                     |                   |
| 76            | 118     | IRQ14    | AT Hard Drive                        |                   |
| 77            | 119     | IRQ15    | Flash Drive                          |                   |
| 78-7F         | 120-127 |          | Reserved by DOS                      | Same as Real Mode |
| 80-F0         | 128-240 |          | Reserved for BASIC                   | Same as Real Mode |
| F1-FF         | 241-255 |          | Reserved by DOS                      | Same as Real Mode |

## PCI Interrupts

Interrupts on Peripheral Component Interconnect (PCI) Local Bus are optional and defined as “level sensitive,” asserted low (negative true), using open drain output drivers. The assertion and de-assertion of an interrupt line, INTx#, is asynchronous to CLK. A device asserts its INTx# line when requesting attention from its device driver. Once the INTx# signal is asserted, it remains asserted until the device driver clears the pending request. When the request is cleared, the device de-asserts its INTx# signal.

PCI defines one interrupt line for a single function device and up to four interrupt lines for a multifunction device or connector. For a single function device, only INTA# may be used while the other three interrupt lines have no meaning. Figure 3-1 on page 3-11 depicts the VMEbus CPU interrupt logic pertaining to VMEbus operations and the PCI expansion site.

Any function on a multifunction device can be connected to any of the INTx# lines. The Interrupt Pin register defines which INTx# line the function uses to request an interrupt. If a device implements a single INTx# line, it is called INTA#; if it implements two lines, they are called INTA# and INTB#; and so forth. For a multifunction device, all functions may use the same INTx# line or each may have its own (up to a maximum of four functions) or any combination thereof. A single function can not generate an interrupt request on more than one INTx# line.

The slave PCI accepts the VMEbus interrupts through lines that are defined by the BIOS. The BIOS defines which interrupt line to utilize depending on which system requires the use of the line.

The PCI-to-VME Bridge has the capability of generating a Non-Maskable Interrupt (NMI) via the PCI SERR# line. Table 3-5 below describes the register bits that are used by the NMI. The SERR interrupt is routed through certain logic back to the NMI input line on the CPU. The CPU reads the NMI Status Control register to determine the NMI source (bits set to 1). After the NMI interrupt routine processes the interrupt, software clears the NMI status bits by setting the corresponding enable/disable bit to 1. The NMI Enable and Real-Time Clock register can mask the NMI signal and disable/enable all NMI sources.

**Table 3-5: NMI Register Bit Descriptions**

| <b>Status Control Register<br/>(I/O Address \$061, Read/Write, Read Only)</b>          |  |
|--|--|
| Bit 7  | SERR# NMI Source Status (Read Only) – This bit is set to 1 if a system board agent detects a system board error. It then asserts the PCI SERR# line. To reset the interrupt, set Bit 2 to 0 and then set it to 1. When writing to port \$061, Bit 7 must be 0. |
| Bit 2  | PCI SERR# Enable (Read/Write) – 1 = Clear and Disable, 0 = Enable  |
| <b>Enable and Real-Time Clock Address Register<br/>(I/O Address \$070, Write Only)</b> |  |
| Bit 7  | NMI Enable – 1 = Disable, 0 = Enable   |

# I/O Ports

The VMEbus CPU incorporates the SMC Super-I/O chip. The SMC chip provides the VMEbus CPU with a standard floppy drive controller and two 16550 UART-compatible serial ports. These ports are RS-232C compliant and support the imposed standard cable length of 50 feet, maximum, in order to meet the requirements of EN61000-4-5 for CE Mark. The Ultra-IDE hard drive interface is provided by the Intel 82371EB (PIIX4E) PCI ISA IDE Xcelerator chip. All ports are present in their standard PC/AT locations using default interrupts.

Figure 3-1: Connections for the PC Interrupt Logic Controller

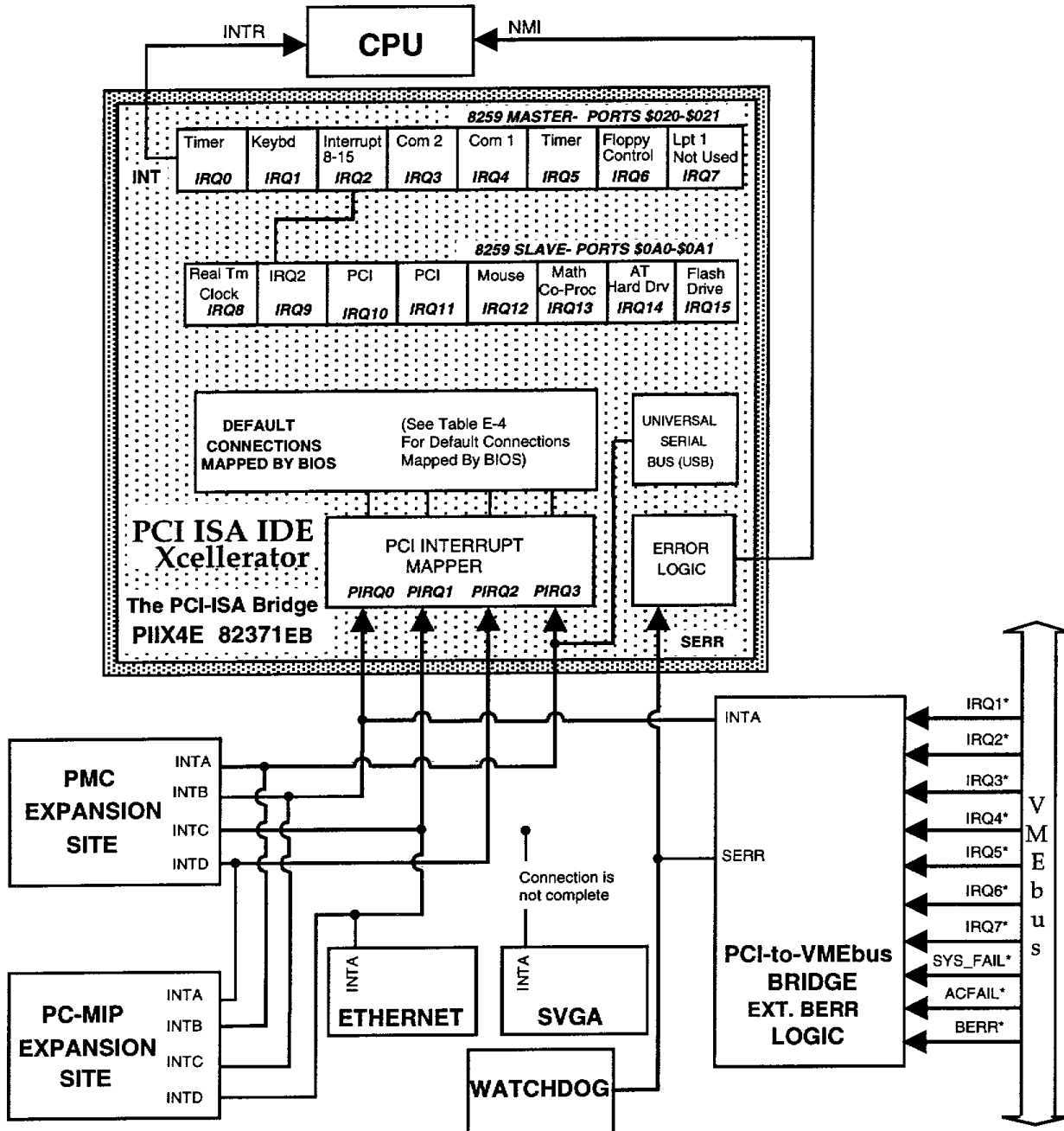

## Video Graphics Adapter

The monitor port on the PMC-version of the VMEbus CPU is controlled by a Chips and Technology 69000 video adapter chip with 2 Mbyte video SDRAM. The video controller chip is hardware and BIOS compatible with the IBM EGA and SXGA standards and also supports VESA high-resolution and extended video modes. Table 3-6 below shows the graphics video modes supported by the PMC version of the VMEbus CPU.

**Table 3-6: Supported Graphics Video Resolutions**

| <b>Screen Resolution</b> | <b>Maximum Colors</b> | <b>Refresh Rates (Hz)</b> |
|--------------------------|-----------------------|---------------------------|
| 640 x 480                | 16 M                  | 60, 75, 85                |
| 800 x 600                | 16 M                  | 60, 75, 85                |
| 1024 x 768               | 64 K                  | 60, 75, 85                |
| 1280 x 1024              | 256                   | 60, 75                    |

Not all SVGA monitors support resolutions and refresh rates beyond 640 x 480 at 60 Hz. Do not attempt to drive a monitor to a resolution or refresh rate beyond its capability.

Floppy disks supplied with the VMEbus CPU also contain video drivers for Windows 95, Windows NT, and other Windows operating systems. Appendix B contains instructions on the incorporation of the video drivers during operating system installation.

---

## *Ethernet Controller*

The network capability is provided by Intel's 82559. This Ethernet controller is PCI bus based and is software configurable. The VMEbus CPU supports 10BaseT and 100BaseTx Ethernet. This ethernet supports LANWorks remote ethernet boot option. Refer to Appendix C for Setup.

### **10BaseT**

A network based on the 10BaseT standard uses unshielded twisted-pair cables, providing an economical solution to networking by allowing the use of existing telephone wiring and connectors. The RJ-45 connector is used with the 10BaseT standard. 10BaseT has a maximum length of 100 m from the wiring hub to the terminal node.

### **100BaseTx**

The VMEbus CPU also supports the 100BaseTx Ethernet. A network based on a 100BaseTx standard uses unshielded twisted-pair cables and a RJ-45 connector. The 100BaseTx has a maximum deployment length of 250 m.

### **LANWorks**

The VMEbus CPU ethernet controller supports remote booting using the LANWorks Ethernet BIOS. Refer to Appendix C for more information on remote Ethernet booting.

The VMEbus CPU features additional capabilities beyond those of a typical IBM PC/AT-compatible CPU. The unit provides three software-controlled, general-purpose timers along with a programmable Watchdog timer for synchronizing and controlling multiple events in embedded applications. The VMEbus CPU also provides a bootable flash disk system and 32 Kbyte of nonvolatile, battery-backed SRAM. These features make the unit ideal for embedded applications, particularly applications where standard hard drives and floppy disk drives cannot be used.

This chapter is divided into the following sections:

- Timers
- Flash Disk
- Watchdog Timer
- Battery Backed SRAM

## Timers

### General

The VMEbus CPU provides a user-programmable 82C54 internal timer/counter. The 82C54 provides three independent, 16-bit timers, each operating at 1 or 2 MHz clock speed determined by the configuration of jumper E8; reference the Timers and NVRAM Battery Select (User Configurable) – Jumper (E8) table in Chapter 2. These timers are completely available to the user and are not dedicated to any PC/AT function. These timers may be used to generate system interrupts.

Events can be timed by either polling the timers or generating a system interrupt via circuitry external to the 82C54. The external circuitry consists of logic which generates the interrupt and a Timer Interrupt Status register which indicates which of the three Timers generated an interrupt.

The 82C54 timers are mapped at I/O address \$500. The interrupt used by the Timers is IRQ5. The Timer Interrupt Status register is available via the Power Management I/O address space. The access to this space is explained in the “Timer Interrupt Status” section below.

### Timer Interrupt Status

A single interrupt, IRQ5, is used by all three Timers. A Timer Interrupt Status register is provided in order to determine which Timer(s) initiated an interrupt. The interrupt status register is a general-purpose input register located, external to the 82C54, at offset 31h from the Power Management Base I/O address. The interrupt status register address can be found by first determining the PCI Configuration Base address for Device ID 7113h and Vendor ID 8086h. The Power Management Base I/O address can be found by reading offset 40h from this PCI Configuration address. The Timer Interrupt Status register bits are located at offset 31h from the Power Management Base I/O address, bits 5, 6, and 7 (refer to Figure 4-1 below).

Figure 4-1: Timer Interrupt Status Register Read/Steps

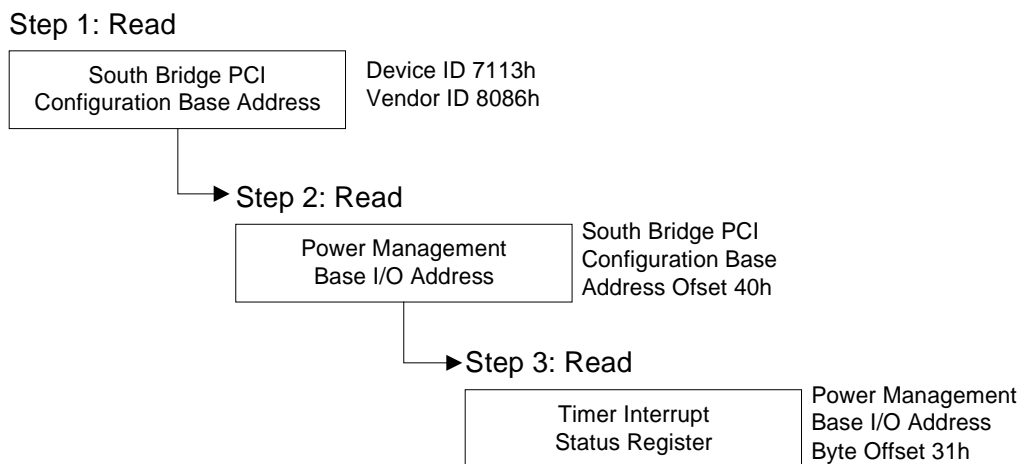

A byte read of Offset 31h from the Power Management Base I/O address is used to obtain these bits. Bits 5, 6, and 7 correspond to Timers 2, 1, and 0, respectively.

**Table 4-1: Timer Interrupt Status Register**

| Bit 07  | Bit 06  | Bit 05  | Bit 04 | Bit 03 | Bit 02 | Bit 01 | Bit 00 |
|---------|---------|---------|--------|--------|--------|--------|--------|
| Timer 0 | Timer 1 | Timer 2 | Unused | Unused | Unused | Unused | Unused |

In order to clear the Timer Interrupt Status register, first write zeros (0's) to the general-purpose output register located at offset 37h of the Power Management Base I/O address bits 3, 4, and 6 (Not bits 3, 4 and 5). Then write ones (1's) to these same bits to re-enable the Timer Interrupt Status register. Bits 3, 4, and 6 correspond to Timers 2, 1, and 0, respectively.

**Table 4-2: Clearing the Timer Interrupt Status Register**

| Bit 07 | Bit 06  | Bit 05 | Bit 04  | Bit 03  | Bit 02 | Bit 01 | Bit 00 |
|--------|---------|--------|---------|---------|--------|--------|--------|
| Unused | Timer 0 | Unused | Timer 1 | Timer 2 | Unused | Unused | Unused |

1. Write zeros (0's) to Power Management Base Address Byte Offset 37h bits 3, 4, and 6.
  2. Write ones (1's) to Power Management Base Address Byte Offset 37h bits 3, 4, and 6.
- Bits 0, 1, 2, 5, and 7 should remain unaffected.

## Clearing the Interrupt

The Timer Interrupts are cleared using the standard procedure for clearing PC/AT IRQ5. Refer to Appendix D for an example of using the 82C54 timers.

## Timer Programming

### Architecture

The VMEbus CPU Timers are mapped in I/O address space starting at \$500. See Table 4-3 below. The Timers, consisting of three 16-bit timers and a Control Word Register (see Figure 4-2 on page 4-4) are read from/written to via an 8-bit data bus.

**Table 4-3: I/O Address of the Control Word Register and Timers**

| I/O Address | Select                |
|-------------|-----------------------|
| \$500       | Timer 0               |
| \$501       | Timer 1               |
| \$502       | Timer 2               |
| \$503       | Control Word Register |

Table 4-3 shows the I/O address's of the Control Word Register and Timers.

The Control Word Register is write only. The Timer status information can be obtained from the Read-Back command (see "Reading" on page 4-7).

Figure 4-2: 82C54 Diagram

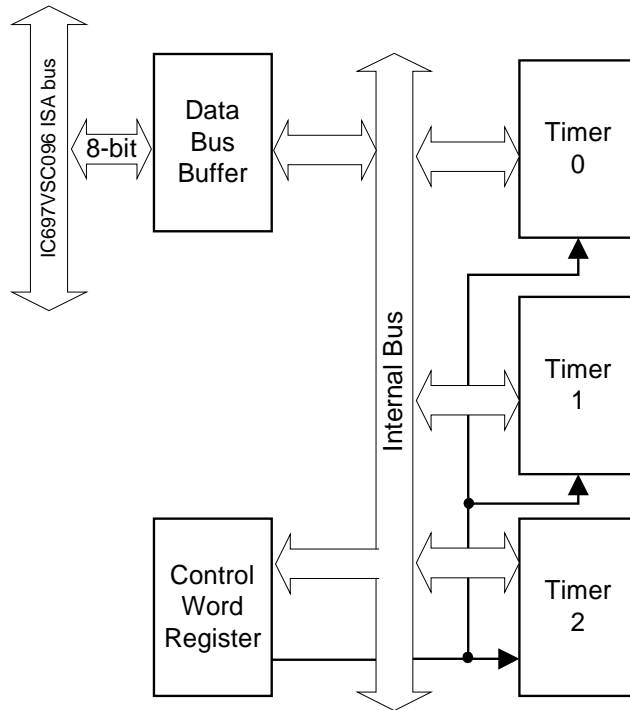

The three Timers, Timer 0, 1, and 2, are functionally equivalent. Therefore only a single Timer will be described. Figure 4-3 on page 4-5 is a block diagram of a Timer. Each Timer is functionally independent. Although the Control word is shown in the Timer block diagram, it is not a part of the Timer, but its contents directly affect how the Timer functions.

The status register, as shown in Figure 4-3 on page 4-5, when latched, contains the present contents of the Control Word Register and the present state of the output and load count flag (The Status Word is available via the Read-Back command, see “Reading” on page 4-7).

The Timer is labeled TE (Timer Element). It is a 16-bit synchronous presettable down counter.

The blocks labeled OLM and OLL are 8-bit Output Latches (OL). The subscripts M and L stand for Most Significant byte and Least Significant byte. These latches usually track the TE but when commanded will latch and hold the present count until the CPU reads the count. When the latched count is read, the OL registers will continue to track the TE. When reading the OL registers, two 8-bit accesses must be performed to retrieve the complete 16-bit value of the Timer as only one latch at a time is enabled. The TE cannot be read; the count is read from the OL registers.

There are two 8-bit registers labeled TRM and TRL (Timer Register). The subscripts M and L stand for Most Significant byte and Least Significant byte. When a new count is written to the Timer, the count is loaded into the TR and later transferred to the TE. The Control logic lets one 8-bit TR register be written to at a time. Two 8-bit writes must be performed to load a complete 16-bit count value. Both TR bytes are transferred to the TE at the same time. The TE cannot be directly written to by the user, the count is written to the TR registers, then latched to the TE.

Figure 4-3: Internal Timer Diagram

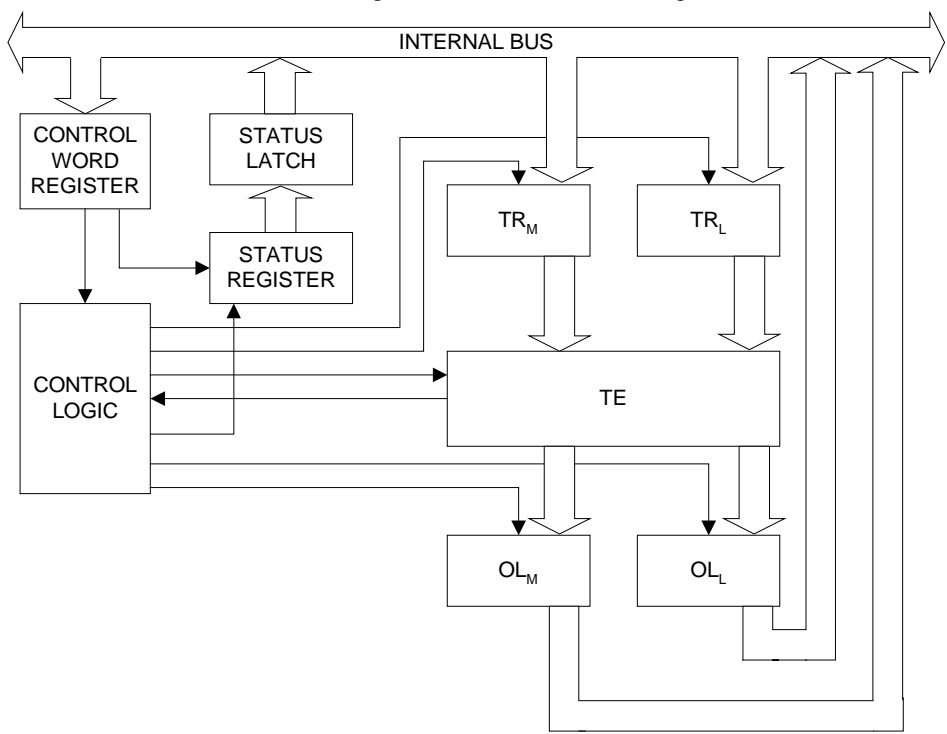

## Writing

The Timers are programmed by first writing a Control Word and then the initial count. The format of the Control Word is shown in Tables 4-4 and 4-5 below and Tables 4-6, 4-7, and 4-8 on page 4-6. All Control Words are written into the Control Word Register while the initial counts are written into the individual Timer registers. The format of the initial count is determined by the Control Word.

Table 4-4: Control Word Format

| D07 | D06 | D05 | D04 | D03 | D02 | D01 | D00 |
|-----|-----|-----|-----|-----|-----|-----|-----|
| ST1 | ST0 | RW1 | RW0 | M2  | M1  | M0  | BCD |

Table 4-5: ST - Select Timer

| ST1* | ST0* | Description                                   |
|------|------|---|
| 0    | 0    | Select Timer 0                                |
| 0    | 1    | Select Timer 1                                |
| 1    | 0    | Select Timer 2                                |
| 1    | 1    | Read-Back Command (See "Reading" on page 4-7) |

\* The ST bits specify which Timer (0, 1, or 2) the Control word refers to or whether this is a Read-Back command.

Table 4-6: RW - Read/Write

| RW1* | RW0* | Description  |
|------|------|--|
| 0    | 0    | Timer Latch Command (See "Reading" on page 4-7)                |
| 0    | 1    | Read/Write least significant byte only                         |
| 1    | 0    | Read/Write most significant byte only                          |
| 1    | 1    | Read/Write least significant byte first, then most significant |

\* The RW bits specify whether this is a Timer Latch command or the byte ordering of the Read/Write transaction.

Table 4-7: M - Mode

| M2* | M1* | M0* | Description |
|-----|-----|-----|-------------|
| 0   | 0   | 0   | Mode 0      |
| 0   | 0   | 1   | Mode 1      |
| X   | 1   | 0   | Mode 2      |
| X   | 1   | 1   | Mode 3      |
| 1   | 0   | 0   | Mode 4      |
| 1   | 0   | 1   | Mode 5      |

\* Only Mode 2 is described in this manual.

Table 4-8: BCD

| BCD* | Description                                  |
|------|--|
| 0    | Binary Timer 16-bits                         |
| 1    | Binary Coded Decimal (BCD) Timer (4 Decades) |

\* The BCD bit specifies whether the Timer count value is in Binary or BCD.

When programming the 82C54, only two rules need to be followed.

1. For each Timer, the Control Word must be written first.
2. The initial count must follow the format specified in the Control Word (least significant byte only, most significant byte only, or least significant byte then most significant byte). As long as these rules are adhered to, any programming sequence is acceptable.

## Reading

There are two methods for reading the timers: the Timer Latch Command and the Read-Back Command.

### Timer Latch Command

The Timer Latch Command allows the reading of a Timer ‘on the fly’ without affecting the timing in process.

Like a Control Word, the Timer Latch Command is written to the Control Word Register (I/O Address \$503, see Table 4-3 on page 4-3). The Select Timer bits (ST1, ST0, see Table 4-5 on page 4-5) select one of the three timers while the Read/Write bits (RW1, RW0, see Table 4-6 on page 4-6) select the Timer Latch Command, RW1 = 0 and RW0 = 0. The selected Timer’s count is latched into the OL registers at the time of the Timer Latch Command. The count is held in the OL latches until it is read. Multiple Timer Latch Commands can be used to latch more than one Timer. Again, each Timer’s count is held latched until it is read.

### Read-Back Command

The Read-Back Command allows the user to view the Timer count, the Timer Mode, the current state of the OUT pin, and the Load Flag of the selected Timer. Like a Control Word, the Read-Back Command is written into the Control Word Register and has the format shown in Tables 4-9 and 4-10 below. The Command applies to the Timer(s) selected by setting the corresponding bits Cnt2, Cnt1, Cnt0 = 1.

**Table 4-9: Read-Back Command Format**

| D07 | D06 | D05   | D04    | D03  | D02  | D01  | D00 |
|-----|-----|-------|--------|------|------|------|-----|
| 1   | 1   | Count | Status | Cnt2 | Cnt1 | Cnt0 | 0   |

**Table 4-10: Read-Back Command Description**

- Bits D07 through D06:** 1 – One value.
- Bit D05:** **Count (Count)** – Latch count of selected Timer(s)
- Bit D04:** **Status (Status)** – Latch status of selected Timer(s)
- Bits D03 through D01:** **Count (Cnt [2:0])** – Select Timers
- Bit D00:** **Reserved (Reserved)** – Reserved for future use; must be 0

The Read-Back Command can be used to latch several Timer counts by setting the Count bit = 0 and selecting the Timers. This is the same as using multiple Timer Latch Commands. Again each Timer’s latched count will be held until it is read.

The Read-Back command can also be used to latch the timer status by setting the Status bit = 0 and selecting the Timers. Status of a Timer is accessed by a read from that Timer (see Table 4-3 on page 4-3). If more than one Timer Status Read-Back command is issued without reading the status, all but the first is ignored.

The format of the Timer Status byte is shown in Tables 4-11 and 4-12 below.

**Table 4-11: Status Byte**

|            |            |            |            |            |            |            |            |
|------------|------------|------------|------------|------------|------------|------------|------------|
| <b>D07</b> | <b>D06</b> | <b>D05</b> | <b>D04</b> | <b>D03</b> | <b>D02</b> | <b>D01</b> | <b>D00</b> |
| OUT        | LOAD       | RW1        | RW0        | M2         | M1         | M0         | BCD        |

**Table 4-12: Status Byte Description**

- Bit D07:** **Out (OUT)** – Current state of Timers OUT pin
- Bit D06:** **Count (Count)** – Count loaded into Timer
- Bits D05 through D00:** **Count ((RW [1:0])(M [2:0]))(BCD)** – Timer Programmed Mode

Bit D7 contains the state of the Timers OUT pin. This allows viewing of the Timer’s OUT pin via software.

Bit D6 indicates when the count written to the Timer is actually loaded into the Timer register. The exact time of the loading depends on the Mode the Timer is in and is defined in the “Mode Definitions” on page 4-9. The count cannot be read from the Timer until it has been loaded. If a count is read before this time, the value read will not be the new count just written. Refer to Table 4-13 below.

Bits D5 through D0 contain the Timer’s programmed mode exactly, bit for bit, like the Timer Control Words bits D5 through D0. See Table 4-4 on page 4-5.

**Table 4-13: LOAD Bit Operation**

| <b>Action</b>                             | <b>Causes</b> |
|---|---------------|
| 1. Write to the Control Word Register (1) | LOAD bit = 1  |
| 2. Write count to Timer (2)               | LOAD bit = 1  |
| 3. New count loaded into Timer            | LOAD bit = 0  |

- (1) Only the Timer specified in the Control Word will have its LOAD bit set to 1. LOAD bits of other Timers are not affected.
- (2) If the Timer is programmed for two byte counts (least significant then most significant), the LOAD bit will go to 1 when the second byte is written.

Both the count and status of the specified Timer(s) can be latched at the same time by setting both the Count bit (D5) and Status bit (D4) to zero (0) in the Read-Back command. If this technique is used, the first read operation of the Timer will return the status while the next one or two reads (depending on whether the Timer is programmed for one or two bytes) will return the count. Succeeding reads will return unlatched counts.

---

## Mode Definitions

The VMEbus CPU utilizes an 82C54 Timer/Counter for its Timers. 82C54 Timer/Counters can be programmed to function in six different modes (numbered Mode 0 through Mode 5). The VMEbus CPU Timers are hardware configured to operate using Mode 2. Only Mode 2 is defined.

Mode 2 functions as a divide by N counter. Once a Control Word and an initial count are written to the Timer, the initial count is loaded on the next Clock cycle. When the count decrements to 1 an interrupt is generated. The Timer then reloads the initial count and the process repeats. This Mode is periodic. For an initial count of N, the sequence repeats every N CLK cycles. An initial count of 1 is illegal.

Writing a new count while the Timer is counting does not affect the current sequence. The new count will be loaded at the end of current sequence.

## Flash Disk

The VMEbus CPU features an on-board Flash mass storage system that allows the host computer to issue commands to read or write blocks to memory in a Flash memory array. This flash disk appears to the user as an intelligent ATA (IDE) disk drive with the same functionality and capabilities as a “rotating media” IDE hard drive.

## Configuration

The flash disk resides on the VMEbus CPU as the secondary IDE bus master device (the secondary IDE bus slave device is not assignable). The default setting is AUTO. This can be seen in the BIOS menus. From the Main BIOS menu select Secondary Master and press the Return key. The default type will be AUTO. Refer to Appendix C, Phoenix BIOS for additional details.

Figure 4-4 below maps the configuration possibilities for a typical system consisting of the VMEbus CPU with a resident flash disk, a hard drive attached to the Primary IDE interface, and a floppy drive attached to the floppy interface.

Figure 4-4: Typical System Configuration

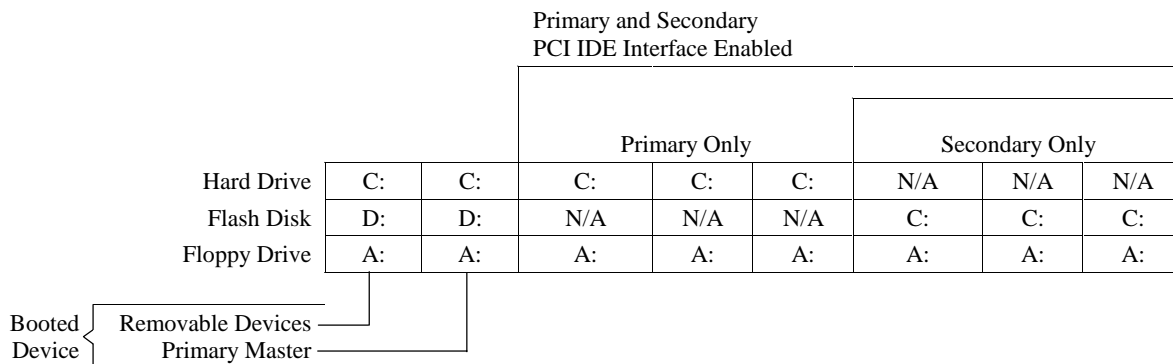

The Primary and Secondary PCI IDE Interfaces are controlled (enabled or disabled) in the Advanced screen of the Phoenix BIOS. The boot sequence is determined by the order of the stack in the Boot menu.

Figure 4-4 above identifies the drive letter assigned to each physical device and indicates in bold lettering the device booted from in each configuration, using devices that were bootable. The term bootable refers to a device on which an operating system has been installed or has been formatted as a system disk using MS-DOS.

## Functionality

The flash disk performs identically to a standard IDE hard drive. Reads and writes to the device are performed using the same methods, utilizing DOS command line entries or the file managers resident in the chosen operating system.

## Advanced Configuration

The previous discussion is based on using the IDE disk devices formatted as one large partition per device. Some applications may require the use of multiple partitions. The following discussion of partitions includes the special procedures that must be followed to allow the creation of multiple partitions on the VMEbus CPU IDE disk devices (including the resident Flash Disk).

Partitions may be either a primary partition or an extended partition. An extended partition may be subdivided farther into logical partitions. Each device may have up to four main partitions, one of which may be an extended partition. However, if multiple primary partitions are created, only one partition may be active at one time. Data in the non-active partitions are not accessible.

Following the creation of the partitioning scheme, the partitions can be formatted to contain the desired file system.

As discussed earlier, a typical system consists of the VMEbus CPU with its resident Flash Disk configured as the Secondary IDE device, a hard drive attached to the Primary IDE interface, and a floppy drive attached to the floppy interface.

Using this configuration, it may be desirable to have a logical device on either IDE device configured as a bootable device, allowing the selection of the boot sequence via the BIOS Features Setup screen. Using this capability, a user could have a system configured with multiple operating systems (OS's) that would then be selectable by assigning the IDE logical device as the boot device.

The DOS utility FDISK is commonly used to configure the partition structure on a hard drive. Other utility programs are available for performing this task. Partition Magic by PowerQuest is a popular and capable commercially available program. Comments that follow pertain to partitioning efforts using FDISK.

### Caution

**Deleting a partition will erase all the data previously held in that partition.**

The Flash Disk will be configured as a single partition device as delivered from the factory. The following sample sequence illustrates a proven method for creating two partitions, with one as an active primary partition. Take note of the instructions to exit FDISK. This has been shown to be an important step in a successful partitioning effort.

1. Power up the VMEbus CPU, and enter CMOS Set-up.
2. Set Primary Master to None. Set Secondary Master to Auto. Set boot device to floppy.
3. Boot DOS from the floppy; verify, on the Bootup screen, that the Flash Disk is shown as Flash Disk 0.
4. Run FDISK.
5. Delete all current partitions (any data currently stored in the partitions will be lost).
6. Exit FDISK, this will cause a reboot, then run FDISK again.
7. Create a primary partition.

8. Create an extended partition and set up a logical device for it.

#### Note

**If only one partition is required its size will be equal to the 96 Mbytes of total configurable memory available within the Flash Disk.**

9. Set the Primary partition as an active partition.
10. Exit FDISK.

#### Note

**If an operating system has been installed on the Flash Disk that modifies the Master Boot Record (MBR), then the following step is required to rewrite the MBR for DOS.**

11. Run FDISK /MBR.
12. Run FORMAT C: (use the /s option if you want the Flash Disk as a bootable DOS device.)
13. Format D: (This is only required if two partitions were created).
14. Reset the CPU and enter the CMOS set-up.
15. Set Primary Master to "AUTO."
16. Set boot device to desired boot source.

Drive letter assignments for a simple system were illustrated in Figure 4-4 on page 4-10. Understanding the order the operating system assigns drive letters is necessary for these multiple partition configurations. The operating system assigns drive letter C to the active primary partition on the first hard disk (the boot device). Drive D is assigned to the first recognized primary partition on the next hard disk. The operating system will continue to assign drive letters to the primary partitions in an alternating fashion between the two drives. Next, logical partitions will be assigned drive letters starting on the first hard drive lettering each logical device sequentially until they are all named, then doing the same sequential lettering of each logical partition on the second hard disk.

#### Note

**Drive letter changes caused by adding a drive or changing the initial partitioning scheme may cause difficulties with an operating system installed prior to the changes. Plan your configuration prior to installing the operating system to minimize difficulties.**

# Watchdog Timer

The VMEbus CPU uses a Dallas DS1384 Watchdog Timekeeping Controller as its Watchdog Timer. The device provides a Time of Day feature, a Watchdog Alarm and a Non-Volatile SRAM controller. The Time of Day feature found within the DS1384 device is explained in this section, but is not utilized by the VMEbus CPU. The actual Time of Day registers used by the VMEbus CPU are located at the standard PC/AT I/O address. The Time of Day feature in the DS1384 Watchdog Timer is available for use by the user at their discretion. The Watchdog Timer provides a Watchdog alarm window and interval timing between 0.01 and 99.99 seconds.

The Non-Volatile SRAM is explained in the “Battery Backed SRAM” on page 4-19.

The Watchdog alarm can, under software control, generate a VME SYSFAIL. Bit 8 of the System Command register (see Table 3-1) is used to enable this option. The System Command Register is 2 bytes wide located at memory address \$D800E.

**Note**

**The Watchdog Timer Interrupt output must be set to Level Mode (see Watchdog Command Register bit 4) to use this option.**

In addition, the Watchdog Alarm is connected via a two state header (E8) to either or neither the CPU reset or the system NMI. The user can direct the Watchdog Alarm to reset the CPU if the jumper is set in the 2-4 position; to initiate a Non-Maskable Interrupt (NMI) if the jumper is in the 4-6 position; or neither if the jumper is completely removed.

Figure 4-5 below shows a generalized block diagram of how the Watchdog Timer is used in the VMEbus CPU. The Watchdog Timer registers are memory-mapped in the bottom fourteen locations of battery-backed SRAM addresses \$D8000 through \$D800D. Table 4-14 on page 4-14 shows the address, content, and the range of each Watchdog Register.

Figure 4-5: Watchdog Alarm Block

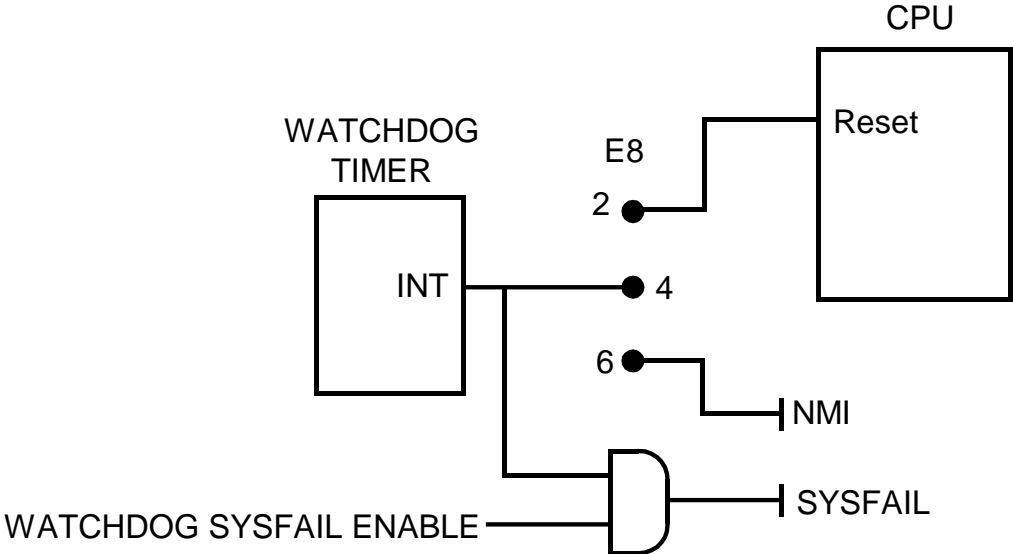

Table 4-14: Watchdog Registers

| Register | Address | Bit 7             | Bit 6                 | Bit 5         | Bit 4  | Bit 3              | Bit 2 | Bit 1 | Bit 0 | Range   |
|----------|---------|-------------------|-----------------------|---------------|--------|--------------------|-------|-------|-------|---------|
| 0        | \$D8000 | 0.1 Seconds (BCD) |                       |               |        | 0.01 Seconds (BCD) |       |       |       | 00 - 99 |
| 1        | \$D8001 | 10 Seconds (BCD)  |                       |               |        | Seconds (BCD)      |       |       |       | 00 - 59 |
| 2        | \$D8002 | 10 Minutes (BCD)  |                       |               |        | Minutes (BCD)      |       |       |       | 00 - 59 |
| 3        | \$D8003 | M                 | 10 Minute Alarm (BCD) |               |        | Minute Alarm (BCD) |       |       |       | 00 - 59 |
| 4        | \$D8004 | 0                 | 12/24                 | AM/PM *       | 10 Hr  | Hours (BCD)        |       |       |       |         |
| 5        | \$D8005 | M                 | 12/24                 | AM/PM *       | 10 Hr  | Hour Alarm (BCD)   |       |       |       |         |
| 6        | \$D8006 | 0                 | 0                     | 0             | 0      | Days (BCD)         |       |       |       | 01 - 07 |
| 7        | \$D8007 | M                 | 0                     | 0             | 0      | Day Alarm (BCD)    |       |       |       | 01 - 07 |
| 8        | \$D8008 | 0                 | 0                     | 10 Date (BCD) |        | Date (BCD)         |       |       |       | 01 - 31 |
| 9        | \$D8009 | Eosc              | 1 **                  | 0             | 10 Mo  | Months (BCD)       |       |       |       | 01 - 12 |
| A        | \$D800A | 10 Years (BCD)    |                       |               |        | Years (BCD)        |       |       |       | 00 - 99 |
| B        | \$D800B | Te                | Ipsw                  | Ibh/lo        | Pu/lvl | Wam                | Tdm   | Waf   | Tdf   |         |
| C        | \$D800C | 0.1 Seconds (BCD) |                       |               |        | 0.01 Seconds (BCD) |       |       |       | 00 - 99 |
| D        | \$D800D | 10 Seconds (BCD)  |                       |               |        | Seconds (BCD)      |       |       |       | 00 - 99 |

\* In the 12 hour mode Bit 5 determines AM (0) or PM (1). In the 24 hour mode Bit 5 combines with Bit 4 to represent the 10 hour value.

\*\* Bit 6 of Register 9 must be set to a 1. If set to a 0, an unused square wave will be generated in the circuit.

Registers 0 through A are Clock, Calendar, Time of Day Registers.

Register B is the Command Register.

Registers C and D are Watchdog Alarm Registers.

The Watchdog Timer contains 14 registers which are 8-bits wide. These registers contain all of the Time of Day, Alarm, Watchdog, Control, and Data information. The Clock Calendar, Alarm, and Watchdog Registers have both external (user accessible) and internal memory locations containing copies of the data. The external memory locations are independent of the internal functions except that they are updated periodically by the transfer of the incremented internal values. Registers 0, 1, 2, 4, 6, 8, 9, and A contain Time of Day and Data information in Binary Coded Decimal (BCD). Registers 3, 5, and 7 contain the Time of Day Alarm information in BCD. The Command Register (Register B) contains data in binary. The Watchdog Alarm Registers are Registers C and D and information stored in these registers is in BCD.

## Time of Day Registers

Registers 0, 1, 2, 4, 6, 8, 9, and A contain Time of Day data in BCD.

Register 0 contains two Time of Day values. Bits 3 - 0 contain the 0.01 Seconds value with a range of 0 to 9 in BCD while Bits 7 - 4 contain the 0.1 Seconds value with a range of 0 to 9 in BCD. This Register has a total range of 0.00 to 0.99 Seconds.

Register 1 contains two Time of Day values. Bits 3 - 0 contain the 1 Seconds value with a range of 0 to 9 in BCD while Bits 7 - 4 contain the 10 Seconds value with a range of 0 to 5 in BCD. This Register has a total range of 0.0 to 59.0 Seconds. Bit 7 of this register will always be zero regardless of what value is written to it.

Register 2 contains two Time of Day values. Bits 3 - 0 contain the 1 Minute value with a range of 0 to 9 in BCD, Bits 7 - 4 contain the 10 Minutes value with a range of 0 to 6 in BCD. This Register has a total range of 0 to 59 Minutes. Bit 7 of this register will always be zero regardless of what value is written to it.

Register 4 contains the Hours value of the Time of Day. The Hours can be represented in either 12- or 24-hour format depending on the state of Bit 6. When Bit 6 is set to a one (1) the format is 12-hour. When Bit 6 is set to a zero (0) the format is 24-hour. For the 12-hour format Bits 3 - 0 contain the 1-hour value with a range of 0 to 9 in BCD and Bit 4 contains the 10-hour value with a range of 0 to 1. In the 12-hour format Bit 5 is used as the AM/PM bit. For AM, Bit 5 is set to zero (0) and for PM, bit 5 is set to one (1). The total range of this register in the 12 hour format is 01 AM to 12 AM and 01 PM to 12 PM.

When Register 4 is in 24-hour format (Bit 6 is set to a zero (0)) Bits 3 - 0 contain the 1-hour value with a range of 0 to 9 in BCD, Bit 5 combines with 4 to represent the 10-hour value. The 10-hour range is from 0 to 2. The total range of register 4 in the 24-hour format is 00 to 23 hours. Bit 7 of register 4 will always be zero regardless of what value is written to it and regardless of format (12- or 24-hour).

Register 6 contains the Days value of the Time of Day. Bits 2 - 0 contain the Days value with a range of 1 to 7 in BCD.

Register 8 contains two Time of Day values. Bits 3 - 0 contain the Date value with a range of 0 to 9 in BCD while Bits 5 - 4 contain the 10 Date value with a range of 0 to 3. This Register has a total range of 01 to 31. Bits 7 - 6 of this register will always be zero regardless of what value is written to it.

Register 9 contains two Time of Day values. Bits 3 - 0 contain the Months value with a range of 0 to 9 in BCD while Bits 4 contain the 10 Date value with a range of 0 to 1. This Register has a total range of 01 to 12. Bit 5 will always be zero regardless of what value is written to it. Bit 6 is unused but must be set to a 1. Bit 7, Eosc, is the clock oscillator enable bit. When this bit is set to a zero (0) the oscillator is internally enabled. When set to a one (1) the oscillator is internally disabled. The oscillator via this bit is usually turned on once during system initialization but can be toggled on and off at the user's discretion.

There are two techniques for reading the Time of Day from the Watchdog Timer. The first is to halt the external Time of Day registers from tracking the internal Time of Day registers by setting the Te bit (Bit 7 of the Command Register) to a logic zero (0), then reading the contents of the Time of Day registers. Using this technique eliminates the chance of the Time of Day changing while the read is taking place. At the end of the read, the Te bit is set to a logic one (1) allowing the external Time of Day registers to resume tracking the internal Time of Day Registers. No time is lost as the internal Time of Day Registers continue to keep time while the external Time of Day registers are halted. This is the recommended method.

The second technique for reading the Time of Day from the Watchdog Timer is to read the external Time of Day registers without halting the tracking of the internal Registers. This is not recommended as the registers may be updated while the reading is taking place, resulting in erroneous data being read.

## Time of Day Alarm Registers

Registers 3, 5, and 7 are the Time of Day Alarm registers and are formatted similar to Register 2, 4, and 6 respectively. Bit 7 of registers 3, 5, and 7 is a mask bit. The mask bits, when active (logic one (1)), disable the use of the particular Time of Day Alarm register in the determination of the Time of Day Alarm (see Table 4-15 below). When all the mask bits are low (0) an alarm will occur when Registers 2, 4, and 6 match the values found in registers 3, 5, and 7. When Register 7's mask bit is set to a logic one (1), register 6 will be disregarded in the determination of the Time of Day alarm and an alarm will occur everyday. When registers 7 and 5's mask bit is set to a logic one (1), Register 6 and 4 will be disregarded in the determination of the Time of Day alarm and an alarm will occur every hour. When Registers 7, 5 and 3's mask bit is set to a logic one (1), Register 6, 4, and 2 will be disregarded in the determination of the Time of Day alarm and an alarm will occur every minute (when register 1's seconds step from 59 to 00).

**Table 4-15: Time of Day Alarm Registers**

| Register |       |      | Comment                                   |
|----------|-------|------|---|
| Minutes  | Hours | Days |   |
| 1        | 1     | 1    | Alarm once per minute                     |
| 0        | 1     | 1    | Alarm when minutes match                  |
| 0        | 0     | 1    | Alarm when hours and minutes match        |
| 0        | 0     | 0    | Alarm when hours, minutes, and days match |

The Time of Day Alarm registers are read and written to in the same format as the Time of Day registers. The Time of Day alarm flag and interrupt are cleared when the alarm registers are read or written.

## Watchdog Alarm Registers

Register C contains two Watchdog alarm values. Bits 3 - 0 contain the 0.01 Seconds value with a range of 0 to 9 in BCD while Bits 7 - 4 contain the 0.1 Seconds value with a range of 0 to 9 in BCD. This Register has a total range of 0.00 to 0.99 Seconds.

Register D contains two Watchdog Alarm values. Bits 3 - 0 contain the 1 Second value with a range of 0 to 9 in BCD while Bits 7 - 4 contain the 10 Seconds value with a range of 0 to 9 in BCD. This Register has a total range of 00.0 to 99.0 Seconds.

The Watchdog Alarm Registers can be read or written in any order. When a new value is entered or the Watchdog registers are read, the Watchdog Timer will start counting down from the entered value. When zero is reached the Watchdog Interrupt Output will go active. If jumper J30 is loaded, the CPU will reset to a known state. Refer to Figure 4-5 on page 4-13. The Watchdog Timer count is reinitialized back to the entered value, the Watchdog flag bit is cleared, and the Watchdog interrupt output is cleared every time either of the registers is accessed. Periodic accesses to the Watchdog Timer will prevent the Watchdog Alarm from occurring. If access does not occur, the alarm will be repetitive. The Watchdog Alarm Register always reads the entered value. The actual countdown value is internal and not accessible to the user. Writing zeroes to Registers C and D will disable the Watchdog Alarm feature.

## Command Register

Register B is the Command Register. Within this register are mask bits, control bits, and flag bits. The following paragraphs describe each bit.

- Bit 07:** **Transfer Enable (Te)** – This bit enables and disables the tracking of data between the internal and external registers. When set to a logic zero (0), tracking is disabled that is the data in the external register is frozen. When set to a logic one (1), tracking is enabled. This bit must be set to a logic one (1) to allow the external register to be updated.
- Bit 06:** **Interrupt Switch (Ipsw)** – This bit toggles the Interrupt Output between the Time of Day Alarm and the Watchdog Alarm. When set to a logic zero (0), the Interrupt Output is from the Watchdog Alarm. When set to a logic one (1), the Interrupt Output is from the Time of Day Alarm.
- Bit 05:** **Reserved (Ibh/Io)** – This bit should be set to a logic low (0).
- Bit 04:** **Interrupt Pulse Mode or Level Mode (Pu/lvl)** – This bit determines whether the Interrupt Output will output as a pulse or a level. When set to a logic zero (0), Interrupt Output will be a level. When set to a logic one (1), Interrupt Output will be a pulse. In pulse mode the Interrupt Output will sink current for a minimum of 3 ms. This bit should be set to a logic one (1).

- 
- Bit 03:** **Watchdog Alarm Mask (Wam)** – Enables/Disables the Watchdog Alarm to Interrupt Output when Ipsw (Bit 6, Interrupt Switch) is set to logic zero (0). When set to a logic zero (0), Watchdog Alarm Interrupt Output will be enabled. When set to a logic one (1), Watchdog Alarm Interrupt Output will be disabled.
- Bit 02:** **Time of Day Alarm Mask (Tdm)** – Enables/Disables the Time of Day Alarm to Interrupt Output when Ipsw (see Bit 6, Interrupt Switch) is set to logic one (1). When set to a logic zero (0), Time of Day Alarm Interrupt Output will be enabled. When set to a logic one (1), Time of Day Alarm Interrupt Output will be disabled.
- Bit 01:** **Watchdog Alarm Flag (Waf)** – This is a read-only bit set to a logic one (1) when a Watchdog Alarm Interrupt occurs. This bit is reset when any of the Watchdog Alarm registers are accessed. When the Interrupt Output is set to Pulse Mode (see Bit 4, Interrupt Pulse Mode or Level Mode), the flag will be set to a logic one (1) only when the Interrupt Output is active.
- Bit 00:** **Time of Day Alarm Flag (Tdf)** – This is a read-only bit set to a logic one (1) when a Time of Day Alarm Interrupt occurs. This bit is reset when any of the Time of Day Alarm registers are accessed. When the Interrupt Output is set to Pulse Mode (see Bit 4, Interrupt Pulse Mode or Level Mode), the flag will be set to a logic one (1) only when the Interrupt Output is active.

---

## *Battery Backed SRAM*

The VMEbus CPU includes 32 K byte of battery-backed SRAM addressed at \$D8018 to \$DFFFF. The lower 24 bytes, \$D8000 to \$D8017, are dedicated to the Watchdog Timer, the System Command Register, the VME BERR Address Register, the VME BERR Address Modifier Register and the Board ID Register and are unavailable for SRAM use. See “Watchdog Timer” on page 4-13. The battery-backed SRAM can be accessed by the CPU at anytime, and can be used to store system data that must not be lost during power-off conditions.

# Chapter 5

## Maintenance

---

---

### Maintenance

This chapter provides information relative to the care and maintenance of the VMEbus CPU product.

If the product malfunctions, verify the following:

- Software
- System configuration
- Electrical connections
- Jumper or configuration settings
- Boards fully inserted into their proper connector location
- Connector pins are clean and free from contamination
- No components of adjacent boards are disturbed when inserting or removing the board from the VMEbus card cage
- Quality of cables and I/O connections

User level repairs are not recommended. Contact your authorized GE Fanuc distributor for a Return Material Authorization (RMA) Number. **This RMA Number must be obtained prior to any return.**

The VMEbus CPU PC/AT-Compatible VMEbus Controller has several connectors for its I/O ports. Figure A-1 shows the locations of the connectors on the VMEbus CPU. Wherever possible, the VMEbus CPU uses connectors and pinouts typical for any desktop PC. This ensures maximum compatibility with a variety of systems.

Connector diagrams in this appendix are generally shown in a natural orientation with the controller board mounted in a VMEbus chassis.

This appendix contains the following sections:

- Ethernet Connector Pinout
- Video Connector Pinout
- Serial Connector Pinout
- Keyboard/Mouse Connector Pinout
- VMEbus Connector Pinout

Figure A-1: VMEbus CPU Connector and Jumper Locations

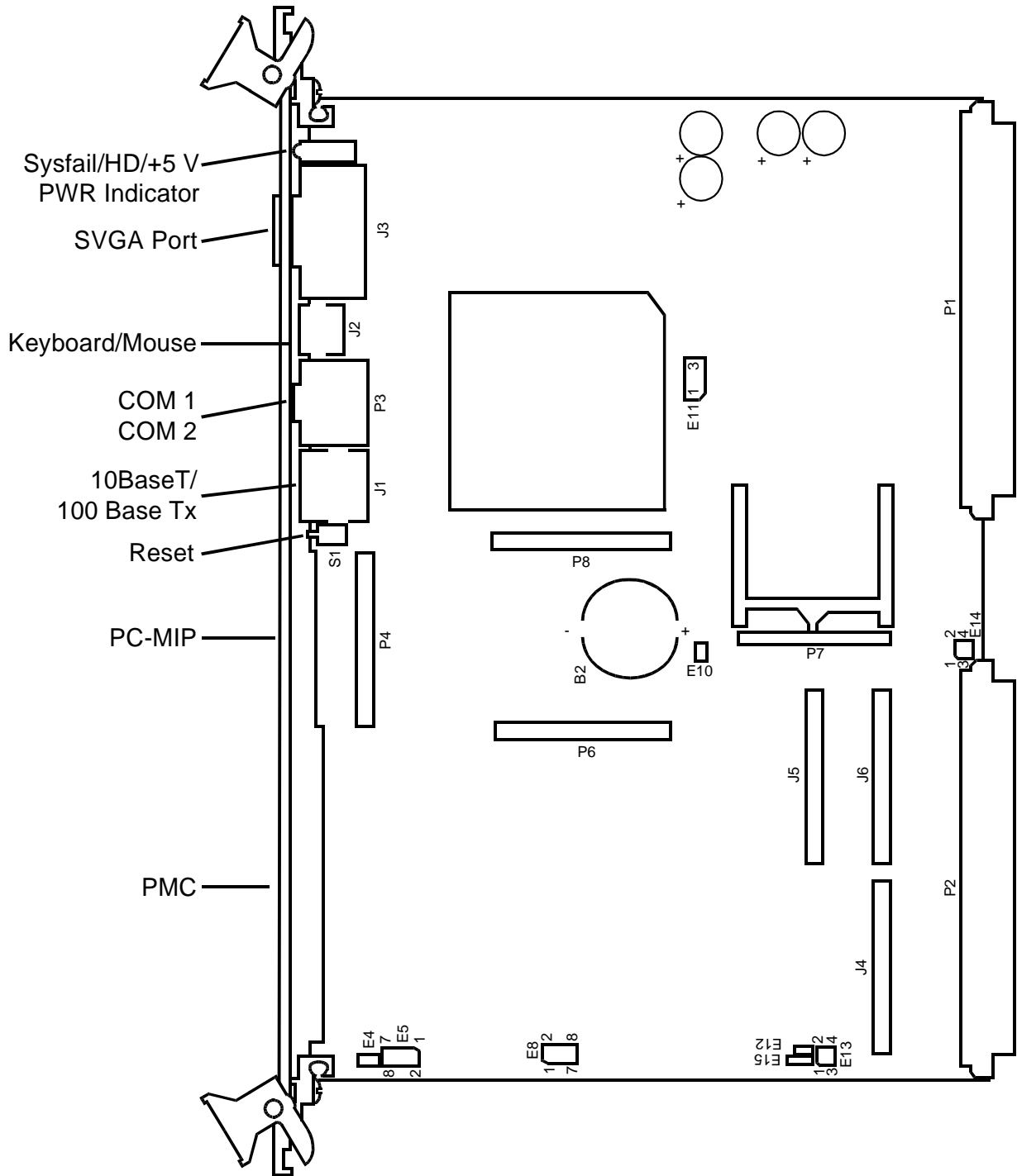

## Ethernet Connector Pinout

The pinout diagram for the Ethernet 10BaseT/100BaseTx and connectors are shown in Figure A-2 below.

Figure A-2: Ethernet Connector Pinout

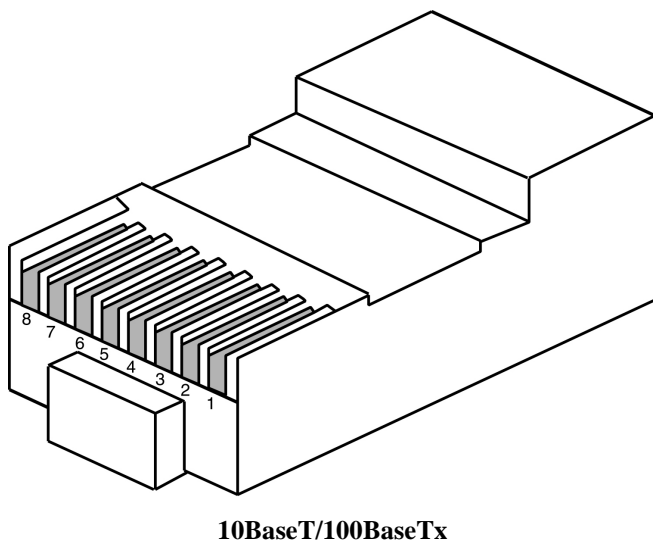

| <b>Ethernet Connector<br/>10BaseT/100BaseTx</b> |                    |                         |
|---|--------------------|-------------------------|
| <b>Pin</b>                                      | <b>Signal Name</b> |                         |
| 1   | TD+                | Transmit Data           |
| 2   | TD-                | Transmit Data           |
| 3   | RD+                | Receive Data            |
| 4   |                    | Transmit Center Tap Out |
| 5   | TX_CT_OUT          | Transmit Center Tap Out |
| 6   | RD-                | Receive Data            |
| 7   | RX_CT_OUT          | Receive Center Tap Out  |
| 8   | RX_CT_OUT          | Receive Center Tap Out  |

## Video Connector Pinout

The video port uses a standard high-density D15 SVGA connector. Figure A-3 below illustrates the pinout.

Figure A-3: Video Connector Pinout

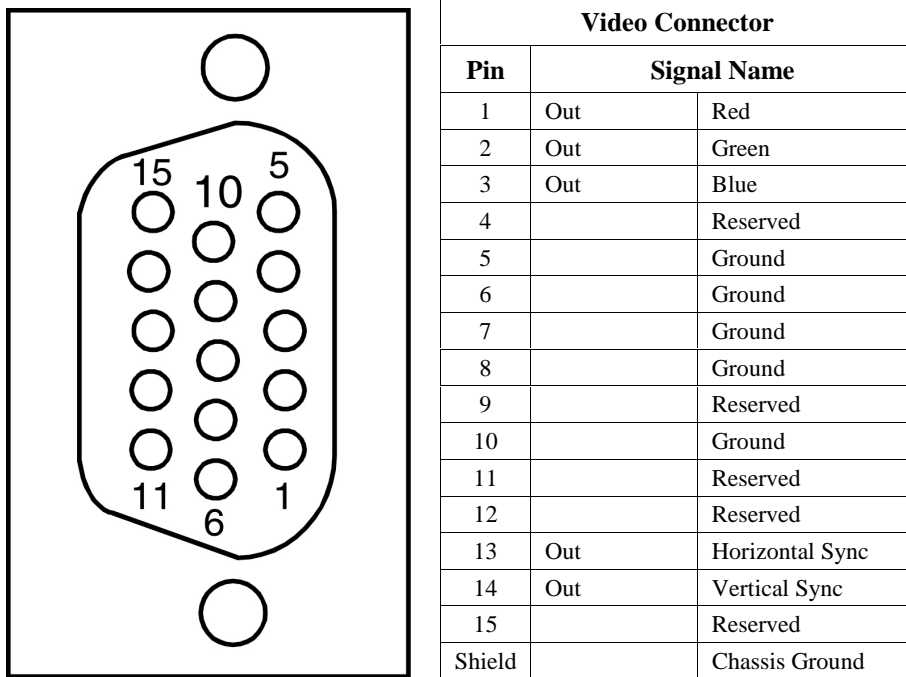

## Serial Connector Pinout

Each standard RS-232 serial port connector is a Microminiature D9 male as shown in the drawing in Figure A-4. These ports are RS-232C compliant and support the imposed standard cable length of 50 feet, maximum, in order to meet the requirements of EN61000-4-5 for CE Mark. Adapters to connect standard D9 serial peripherals to the board are available. Please refer to the product specification sheet for ordering information.

Figure A-4: Serial Connector Pinouts

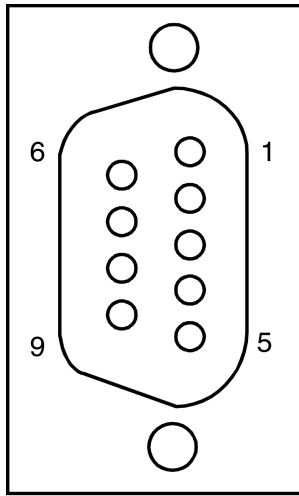

| COM 1 and COM 2 Serial Port Connectors |     |               |                     |
|--|-----|---------------|---------------------|
| D9 Pin                                 | DIR | RS-232 Signal | Function            |
| 1                                      | In  | DCD           | Data Carrier Detect |
| 2                                      | In  | RX            | Receive Data        |
| 3                                      | Out | TX            | Transmit Data       |
| 4                                      | Out | DTR           | Data Terminal Ready |
| 5                                      |     | GND           | Signal Ground       |
| 6                                      | In  | DSR           | Data Set Ready      |
| 7                                      | Out | RTS           | Request to Send     |
| 8                                      | In  | CTS           | Clear to Send       |
| 9                                      | In  | RI            | Ring Indicator      |
| Shield                                 |     |               | Chassis Ground      |

## Keyboard/Mouse Connector Pinout

The keyboard/Mouse connector is a standard 6-pin female mini-DIN PS/2 connector as shown in Figure A-5 below. The Keyboard/Mouse Y-cable connects to the Keyboard/Mouse connector on the VMEbus CPU and provides a separate connector for both Keyboard and Mouse. The pinout of these connectors are shown in Table A-1 below.

Figure A-5: Keyboard Connector Pinout

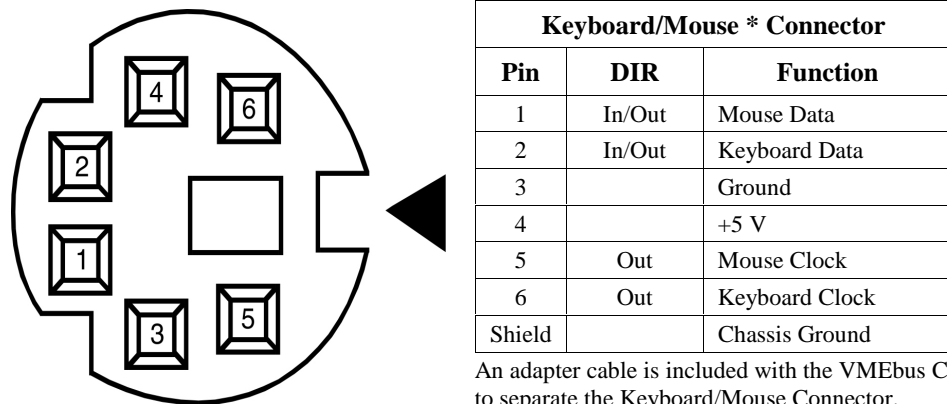

An adapter cable is included with the VMEbus CPU to separate the Keyboard/Mouse Connector.

Table A-1: Keyboard/Mouse Y Splitter Cable

| Keyboard |        |                | Mouse  |        |                |
|----------|--------|----------------|--------|--------|----------------|
| Pin      | Dir    | Function       | Pin    | Dir    | Function       |
| 1        | In/Out | Keyboard Data  | 1      | In/Out | Mouse Data     |
| 2        |        | Unused         | 2      |        | Unused         |
| 3        |        | Ground         | 3      |        | Ground         |
| 4        |        | +5V            | 4      |        | +5V            |
| 5        | Out    | Keyboard Clock | 5      | Out    | Mouse Clock    |
| 6        |        | Unused         | 6      |        | Unused         |
| Shield   |        | Chassis Ground | Shield |        | Chassis Ground |

## VMEbus Connector Pinout

Figure A-6 shows the location of the VMEbus P1 and P2 connectors and their orientation. Table A-2 below and Table A-3 on page A-10 shows the pin assignments for the VMEbus connectors.

Figure A-6: VME64 Connector Diagram

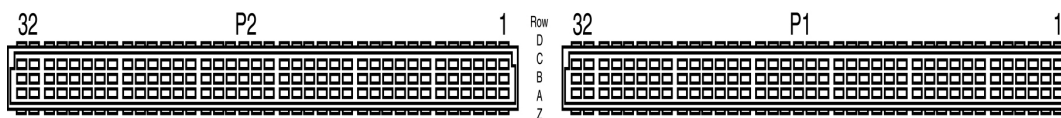

Table A-2: P1 - VME64 Connector

| A  | Signal     | Description          | B  | Signal      | Description        | C  | Signal       | Description          |
|----|------------|----------------------|----|-------------|--------------------|----|--------------|----------------------|
| 1  | VME_D[0]   | VME Data Bus Line 0  | 1  | VME_BBSY-   | Bus Busy           | 1  | VME_D[8]     | VME Data Bus Line 8  |
| 2  | VME_D[1]   | VME Data Bus Line 1  | 2  | VME_BCLR-   | Bus Clear          | 2  | VME_D[9]     | VME Data Bus Line 9  |
| 3  | VME_D[2]   | VME Data Bus Line 2  | 3  | VME_ACFAIL- | Power Fail         | 3  | VME_D[10]    | VME Data Bus Line 10 |
| 4  | VME_D[3]   | VME Data Bus Line 3  | 4  | VME_BG0IN-  | Bus Grant 0 In     | 4  | VME_D[11]    | VME Data Bus Line 11 |
| 5  | VME_D[4]   | VME Data Bus Line 4  | 5  | VME_BG0OUT- | Bus Grant 0 Out    | 5  | VME_D[12]    | VME Data Bus Line 12 |
| 6  | VME_D[5]   | VME Data Bus Line 5  | 6  | VME_BG1IN-  | Bus Grant 1 In     | 6  | VME_D[13]    | VME Data Bus Line 13 |
| 7  | VME_D[6]   | VME Data Bus Line 6  | 7  | VME_BG1OUT- | Bus Grant 1 Out    | 7  | VME_D[14]    | VME Data Bus Line 14 |
| 8  | VME_D[7]   | VME Data Bus Line 7  | 8  | VME_BG2IN-  | Bus Grant 2 In     | 8  | VME_D[15]    | VME Data Bus Line 15 |
| 9  | GND        | Ground               | 9  | VME_BG2OUT- | Bus Grant 2 Out    | 9  | GND          | Ground               |
| 10 | VME_SYSCLK | VME Bus System Clock | 10 | VME_BG3IN-  | Bus Grant 3 In     | 10 | VME_SYSFAIL- | System Failure       |
| 11 | GND        | Ground               | 11 | VME_BG3OUT- | Bus Grant 3 Out    | 11 | VME_BERR-    | Bus Error            |
| 12 | VME_DS1-   | Data Strobe 1        | 12 | VME_BR0-    | Bus Request 0      | 12 | VME_SYSRST-  | System Reset         |
| 13 | VME_DS0-   | Data Strobed         | 13 | VME_BR1-    | Bus Request 1      | 13 | VME_LWORD-   | Long Word            |
| 14 | VME_WRITE- | Write Enable         | 14 | VME_BR2-    | Bus Request 2      | 14 | VME_AM5      | Address Modifier 5   |
| 15 | GND        | Ground               | 15 | VME_BR3-    | Bus Request 3      | 15 | VME_A[23]    | VME Address Line 23  |
| 16 | VME_DTACK- | Data Acknowledge     | 16 | VME_AM0     | Address Modifier 0 | 16 | VME_A[22]    | VME Address Line 22  |
| 17 | GND        | Ground               | 17 | VME_AM1     | Address Modifier 1 | 17 | VME_A[21]    | VME Address Line 21  |
| 18 | VME_AS-    | Address Strobe       | 18 | VME_AM2     | Address Modifier 2 | 18 | VME_A[20]    | VME Address Line 20  |
| 19 | GND        | Ground               | 19 | VME_AM3     | Address Modifier 3 | 19 | VME_A[19]    | VME Address Line 19  |

| A  | Signal       | Description           | B  | Signal      | Description | C  | Signal    | Description         |
|----|--------------|-----------------------|----|-------------|-------------|----|-----------|---------------------|
| 20 | VME_IACK-    | VME IRQ Acknowledge   | 20 | GND         | Ground      | 20 | VME_A[18] | VME Address Line 18 |
| 21 | VME_IACKIN-  | Interrupt Acknowledge | 21 | N.C.        | No Connect  | 21 | VME_A[17] | VME Address Line 17 |
| 22 | VME_IACKOUT- | Int Ack Out           | 22 | N.C.        | No Connect  | 22 | VME_A[16] | VME Address Line 16 |
| 23 | VME_AM4      | Address Modifier 4    | 23 | GND         | Ground      | 23 | VME_A[15] | VME Address Line 15 |
| 24 | VME_A[7]     | VME Address Line 7    | 24 | VME_IRQ[7]- | IRQ Line 7  | 24 | VME_A[14] | VME Address Line 14 |
| 25 | VME_A[6]     | VME Address Line 6    | 25 | VME_IRQ[6]- | IRQ Line 6  | 25 | VME_A[13] | VME Address Line 13 |
| 26 | VME_A[5]     | VME Address Line 5    | 26 | VME_IRQ[5]- | IRQ Line 5  | 26 | VME_A[12] | VME Address Line 12 |
| 27 | VME_A[4]     | VME Address Line 4    | 27 | VME_IRQ[4]- | IRQ Line 4  | 27 | VME_A[11] | VME Address Line 11 |
| 28 | VME_A[3]     | VME Address Line 3    | 28 | VME_IRQ[3]- | IRQ Line 3  | 28 | VME_A[10] | VME Address Line 10 |
| 29 | VME_A[2]     | VME Address Line 2    | 29 | VME_IRQ[2]- | IRQ Line 2  | 29 | VME_A[9]  | VME Address Line 9  |
| 30 | VME_A[1]     | VME Address Line 1    | 30 | VME_IRQ[1]- | IRQ Line 1  | 30 | VME_A[8]  | VME Address Line 8  |
| 31 | -12V         | -12V Power            | 31 | N.C.        | No Connect  | 31 | +12V      | +12V Power          |
| 32 | +5V          | Power                 | 32 | +5V         | Power       | 32 | +5V       | Power               |

| D  | Signal | Description          | Z  | Signal | Description |
|----|--------|----------------------|----|--------|-------------|
| 1  | N.C.   | No Connect           | 1  | N.C.   | No Connect  |
| 2  | N.C.   | No Connect           | 2  | N.C.   | No Connect  |
| 3  | N.C.   | No Connect           | 3  | N.C.   | No Connect  |
| 4  | N.C.   | No Connect           | 4  | N.C.   | No Connect  |
| 5  | N.C.   | No Connect           | 5  | N.C.   | No Connect  |
| 6  | N.C.   | No Connect           | 6  | N.C.   | No Connect  |
| 7  | N.C.   | No Connect           | 7  | N.C.   | No Connect  |
| 8  | N.C.   | No Connect           | 8  | N.C.   | No Connect  |
| 9  | GA[5]  | Geographic Address 5 | 9  | N.C.   | No Connect  |
| 10 | GA[0]  | Geographic Address 0 | 10 | N.C.   | No Connect  |
| 11 | GA[1]  | Geographic Address 1 | 11 | N.C.   | No Connect  |
| 12 | N.C.   | No Connect           | 12 | N.C.   | No Connect  |
| 13 | GA[2]  | Geographic Address 2 | 13 | N.C.   | No Connect  |

| <b>D</b> | <b>Signal</b> | <b>Description</b>   | <b>Z</b> | <b>Signal</b> | <b>Description</b> |
|----------|---------------|----------------------|----------|---------------|--------------------|
| 14       | N.C.          | No Connect           | 14       | N.C.          | No Connect         |
| 15       | GA[3]         | Geographic Address 3 | 15       | N.C.          | No Connect         |
| 16       | N.C.          | No Connect           | 16       | N.C.          | No Connect         |
| 17       | GA[4]         | Geographic Address 4 | 17       | N.C.          | No Connect         |
| 18       | N.C.          | No Connect           | 18       | N.C.          | No Connect         |
| 19       | N.C.          | No Connect           | 19       | N.C.          | No Connect         |
| 20       | N.C.          | No Connect           | 20       | N.C.          | No Connect         |
| 21       | N.C.          | No Connect           | 21       | N.C.          | No Connect         |
| 22       | N.C.          | No Connect           | 22       | N.C.          | No Connect         |
| 23       | N.C.          | No Connect           | 23       | N.C.          | No Connect         |
| 24       | N.C.          | No Connect           | 24       | N.C.          | No Connect         |
| 25       | N.C.          | No Connect           | 25       | N.C.          | No Connect         |
| 26       | N.C.          | No Connect           | 26       | N.C.          | No Connect         |
| 27       | N.C.          | No Connect           | 27       | N.C.          | No Connect         |
| 28       | N.C.          | No Connect           | 28       | N.C.          | No Connect         |
| 29       | N.C.          | No Connect           | 29       | N.C.          | No Connect         |
| 30       | N.C.          | No Connect           | 30       | N.C.          | No Connect         |
| 31       | N.C.          | No Connect           | 31       | N.C.          | No Connect         |
| 32       | N.C.          | No Connect           | 32       | N.C.          | No Connect         |

Table A-3: P2 - VME64 Connector

| A  | Signal    | Description      | B  | Signal    | Description         | C  | Signal    | Description     |
|----|-----------|------------------|----|-----------|---------------------|----|-----------|-----------------|
| 1  | GND       | Ground           | 1  | +5V       | Power               | 1  | IDERST#   | IDE Control     |
| 2  | IDED[8]   | IDE Data Line 8  | 2  | GND       | Ground              | 2  | IDED[7]   | IDE Data Line 7 |
| 3  | IDED[9]   | IDE Data Line 9  | 3  | N.C.      | No Connect          | 3  | IDED[6]   | IDE Data Line 6 |
| 4  | IDED[10]  | IDE Data Line 10 | 4  | VME_A[24] | VME Address Line 24 | 4  | IDED[5]   | IDE Data Line 5 |
| 5  | IDED[11]  | IDE Data Line 11 | 5  | VME_A[25] | VME Address Line 25 | 5  | IDED[4]   | IDE Data Line 4 |
| 6  | IDED[12]  | IDE Data Line 12 | 6  | VME_A[26] | VME Address Line 26 | 6  | IDED[3]   | IDE Data Line 3 |
| 7  | IDED[13]  | IDE Data Line 13 | 7  | VME_A[27] | VME Address Line 27 | 7  | IDED[2]   | IDE Data Line 2 |
| 8  | IDED[14]  | IDE Data Line 14 | 8  | VME_A[28] | VME Address Line 28 | 8  | IDED[1]   | IDE Data Line 1 |
| 9  | IDED[15]  | IDE Data Line 15 | 9  | VME_A[29] | VME Address Line 29 | 9  | IDED[0]   | IDE Data Line 0 |
| 10 | N.C.      | No Connect       | 10 | VME_A[30] | VME Address Line 30 | 10 | IOCSI.64# | IDE Control     |
| 11 | IDELIOW0- | IDE Control      | 11 | VME_A[31] | VME Address Line 31 | 11 | GND       | Ground          |
| 12 | IDELIOR0- | IDE Control      | 12 | GND       | Ground              | 12 | GND       | Ground          |
| 13 | IDERDY    | IDE Control      | 13 | +5V       | Power               | 13 | GND       | Ground          |
| 14 | GND       | Ground           | 14 | VME_D[16] | VME Data Line 16    | 14 | IDESELA   | IDE Control     |
| 15 | GND       | Ground           | 15 | VME_D[17] | VME Data Line 17    | 15 | N.C.      | No Connect      |
| 16 | GND       | Ground           | 16 | VME_D[18] | VME Data Line 18    | 16 | N.C.      | No Connect      |
| 17 | A1        | IDE Control      | 17 | VME_D[19] | VME Data Line 19    | 17 | A2        | IDE Control     |
| 18 | CSOP      | IDE Control      | 18 | VME_D[20] | VME Data Line 20    | 18 | A0        | IDE Control     |
| 19 | HD_ACTA-  | IDE Control      | 19 | VME_D[21] | VME Data Line 21    | 19 | CS1P      | IDE Control     |
| 20 | DRATE0    | Floppy Control   | 20 | VME_D[22] | VME Data Line 22    | 20 | DENSEL    | Floppy Control  |
| 21 | GND       | Ground           | 21 | VME_D[23] | VME Data Line 23    | 21 | INDEX-    | Floppy Control  |
| 22 | DR1-      | Floppy Control   | 22 | GND       | Ground              | 22 | MTR0-     | Floppy Control  |
| 23 | GND       | Ground           | 23 | VME_D[24] | VME Data Line 24    | 23 | DR0-      | Floppy Control  |
| 24 | GND       | Ground           | 24 | VME_D[25] | VME Data Line 25    | 24 | MTR1-     | Floppy Control  |
| 25 | GND       | Ground           | 25 | VME_D[26] | VME Data Line 26    | 25 | STEP-     | Floppy Control  |

| A  | Signal | Description    | B  | Signal    | Description      | C  | Signal | Description    |
|----|--------|----------------|----|-----------|------------------|----|--------|----------------|
| 26 | GND    | Ground         | 26 | VME_D[27] | VME Data Line 27 | 26 | WDATA- | Floppy Control |
| 27 | GND    | Ground         | 27 | VME_D[28] | VME Data Line 28 | 27 | TRK0-  | Floppy Control |
| 28 | GND    | Ground         | 28 | VME_D[29] | VME Data Line 29 | 28 | RDATA- | Floppy Control |
| 29 | DSKCHG | Floppy Control | 29 | VME_D[30] | VME Data Line 30 | 29 | HDSEL  | Floppy Control |
| 30 | GND    | Ground         | 30 | VME_D[31] | VME Data Line 31 | 30 | DIR-   | Floppy Control |
| 31 | +5V    | Power          | 31 | GND       | Ground           | 31 | WGATE- | Floppy Control |
| 32 | +5V    | Power          | 32 | +5V       | Power            | 32 | WP-    | Floppy Control |

| D  | Signal   | Description | Z  | Signal   | Description |
|----|----------|-------------|----|----------|-------------|
| 1  | CONN[1]  | P8-2        | 1  | CONN[2]  | P8-2        |
| 2  | CONN[3]  | P8-3        | 2  | GND      | Ground      |
| 3  | CONN[4]  | P8-4        | 3  | CONN[5]  | P8-5        |
| 4  | CONN[6]  | P8-6        | 4  | GND      | Ground      |
| 5  | CONN[7]  | P8-7        | 5  | CONN[8]  | P8-8        |
| 6  | CONN[9]  | P8-9        | 6  | GND      | Ground      |
| 7  | CONN[10] | P8-10       | 7  | CONN[11] | P8-11       |
| 8  | CONN[12] | P8-12       | 8  | GND      | Ground      |
| 9  | CONN[13] | P8-13       | 9  | CONN[14] | P8-14       |
| 10 | CONN[15] | P8-15       | 10 | GND      | Ground      |
| 11 | CONN[16] | P8-16       | 11 | CONN[17] | P8-17       |
| 12 | CONN[18] | P8-18       | 12 | GND      | Ground      |
| 13 | CONN[19] | P8-19       | 13 | CONN[20] | P8-20       |
| 14 | CONN[21] | P8-21       | 14 | GND      | Ground      |
| 15 | CONN[22] | P8-22       | 15 | CONN[23] | P8-23       |
| 16 | CONN[24] | P8-24       | 16 | GND      | Ground      |
| 17 | CONN[25] | P8-25       | 17 | CONN[26] | P8-26       |
| 18 | CONN[27] | P8-27       | 18 | GND      | Ground      |
| 19 | CONN[28] | P8-28       | 19 | CONN[29] | P8-29       |
| 20 | CONN[30] | P8-30       | 20 | GND      | Ground      |
| 21 | CONN[31] | P8-31       | 21 | CONN[32] | P8-32       |
| 22 | CONN[33] | P8-33       | 22 | GND      | Ground      |
| 23 | CONN[34] | P8-34       | 23 | CONN[35] | P8-35       |
| 24 | CONN[36] | P8-36       | 24 | GND      | Ground      |
| 25 | CONN[37] | P8-37       | 25 | CONN[38] | P8-38       |
| 26 | CONN[39] | P8-39       | 26 | GND      | Ground      |
| 27 | CONN[40] | P8-40       | 27 | CONN[41] | P8-41       |
| 28 | CONN[42] | P8-42       | 28 | GND      | Ground      |
| 29 | CONN[43] | P8-43       | 29 | CONN[44] | P8-44       |
| 30 | CONN[45] | P8-45       | 30 | GND      | Ground      |
| 31 | GND      | Ground      | 31 | CONN[46] | P8-46       |
| 32 | N.C.     | No Connect  | 32 | GND      | Ground      |



The VMEbus CPU provides high-performance video and Local Area Network (LAN) access by means of on-board PCI-based adapters and associated software drivers. The PCI-based video adapter used on the VMEbus CPU is the Intel 69000. High-performance LAN operation, including 10BaseT and 100BaseTx, is provided by the Intel 82559 Ethernet controller chip.

To optimize performance of each of these PCI-based subsystems, the VMEbus CPU is provided with software drivers compatible with DOS, Windows 95, and Windows NT operating systems. The following paragraphs provide instructions for loading and installing the adapter software.

## **Driver Software Installation**

In order to properly use the Video and LAN adapters of the VMEbus CPU, the user must install the driver software located on the distribution diskettes provided with the unit. Detailed instructions for installation of the drivers during installation of Windows 95 or Windows NT (Versions 4.0) operating systems are described in the following sections.

## Windows 95

1. Format the hard drive with MS-DOS.
2. Begin the installation of Windows 95, following the instructions provided by the Windows 95 manual.
3. When the **Windows 95 Setup Wizard Screen** displays, select **Typical** under **Setup Option** and then click **Next**.
4. When the **Analyzing Your Computer** screen displays, select the **Network Adapter** check box and then click **Next**.
5. When the **Windows Components Screen** displays, select **Install The Most Common Components** and then click **Next**.
6. Continue with the installation until Windows 95 is completely installed and the computer has rebooted.
7. When Windows 95 is restarted for the first time after installation, the **New Hardware Found** dialog window displays. Select **Driver From Disk Provided By Manufacturer** and then click **OK**.
8. When the **Install From Disk** window displays, insert GE Fanuc Driver Disk **320-500037-005** into drive A and ensure **A:\** is in the **Copy Manufacturer's Files From** field, then click **OK**. Follow the onscreen prompts to complete the installation.
9. From the **Control Panel**, double-click the **Network** icon.
10. In the **Network** dialog box, click **File And Print Sharing**, choose the appropriate items for your system, and then click **OK**.
11. When the **Network** window displays, click **OK**. When prompted, insert the diskettes needed to complete the network installation, if required.
12. When the system prompts you to restart your computer, click **Yes** for the network settings to take effect.

---

## Video Driver

Follow the instructions below to install the video driver for Windows 95.

### Part 1

1. Insert the Windows 95 drivers diskette into drive A.
2. From the **Start** menu, select **Run**.
3. Type **A:\w95500**.
4. When the **Welcome** screen displays, click **Next**.
5. If you agree with the license agreement, click **Yes**.
6. Click **Finish** to complete the installation and restart the computer.

### Part 2

Verify that Windows 95 is actually using the CHIPS driver, and then perform the following steps.

1. Open the Windows 95 control panel.
2. Double click the **Display** icon.
3. Click on the **Settings** tab.
  - Check Adapter/Driver Information:  
For Win95a, select **Change Display Type**.
  - For Win95b, select **Advanced Properties**.

If the driver is installed and operating properly, the Chips and Technologies device is specified in the **Adapter Type** box.

## *Windows NT (Version 4.0)*

Windows NT 4.0 includes drivers for the on-board LAN, and video adapters. The following steps are required to configure the LAN for operation.

1. Follow the normal Windows NT 4.0 installation until you reach the **Windows NT Workstation Setup** window, which states **Windows NT Needs To Know How This Computer Should Participate On A Network**.
2. Select **This Computer Will Participate On A Network**.
3. Select **Wired To The Network**.
4. Click **Next**.
5. When the next screen displays, click **Select From List**.
6. Click **Have Disk**.
7. Insert disk **320-500037-006** into drive A.
8. Click **OK**.
9. In the **Select OEM Option**, select **Intel Pro Adapter**.
10. Click **OK**.
11. Select the above entry on the displayed list.
12. Click **Next**.
13. Select **NetBEUI Protocol (only)**.
14. Click **Next**.
15. Click **Next** to install selected components.
16. Click **Next** to start the network connection.
17. Step through the remaining screens, providing the data pertinent to your network.
18. Continue through the setup procedure until the **Detected Display** window displays. Click **OK** to continue.
19. In the **Display Properties** window, click **Test**.

### **Note**

**Windows NT 4.0 does not allow the selection of the Intel video drivers during initial setup.**

If the display test is successful, click **OK** to continue. If the display test is not successful, you may have to adjust the display parameter to find a functional setting, for example a lower resolution or lower number of colors.

20. Continue with the procedure until the **Windows NT Setup** window displays, and the click **Restart Computer**.

- 
21. When the computer reboots, double-click the **My Computer** icon to display the **My Computer** window.
  22. Double-click the **Control Panel** icon in the **My Computer** window.
  23. Double-click the **Display** icon in the **Control Panel**.
  24. Select the **Settings** tab in the **Display Properties** window, then click the **Display Type** button.
  25. In the **Display Type** window, click **Change**.
  26. In the **Change Display** window, click **Have Disk**.
  27. Insert disk **320-500037-003** into drive A.
  28. Click **OK**.
  29. **Intel 69000** displays in the **Change Display** window.
  30. Click **OK**.
  31. Proceed as directed, removing the driver disk from the floppy drive, and the computer will restart to activate the new settings. When the system reboots, the **Invalid Display Settings** screen will be displayed.
  32. Click **OK**.
  33. Click **Settings** in the **Display Properties** screen and then click **Test**.  
The **Testing Mode** screen displays.
  34. Click **OK**.
  35. If the bitmap test image is displayed correctly, click **OK**.
- The unit is now configured for operation under Windows NT 4.0.

The VMEbus CPU utilizes the BIOS (Basic Input/Output System) in the same manner as other PC/AT compatible computers. This appendix describes the menus and options associated with the VMEbus CPU BIOS.

## System BIOS Setup Utility

During system bootup, press the F2 key to access the Phoenix BIOS Main screen. From this screen, the user can select any section of the Phoenix (system) BIOS for configuration, such as floppy drive configuration or system memory.

The parameters shown throughout this section are the default values.

## Help Window

The help window on the right side of each menu displays the help text for the currently selected field. It updates as you move the cursor to each field. Pressing **F1** or **ALT- + H** on any menu brings up the **General Help** window that describes the legend keys and their alternates. The scroll bar on the right of any window indicates that there is more than one page of information in the window. Use **PAGE UP** and **PAGE DOWN** to display all the pages. Pressing **HOME** and **END** displays the first and last page. Pressing **ENTER** displays each page and then exits the window. Press **ESC** to exit the current window.

## Main Menu

The **Main** menu allows the user to select QuickBoot, set the system clock and calendar, record disk drive parameters, and set selected functions for the keyboard.

Figure C-1: Phoenix BIOS Main Menu

| Phoenix Setup Utility |                    |             |       |                   |  |
|-----------------------|--------------------|-------------|-------|-------------------|--|
| MAIN                  | Advanced           | Security    | Power | Boot              | Exit   |
| QuickBoot Mode:       | [Enabled]          |             |       |                   | Item Specific Help<br>Allows the system to skip certain tests while booting. This will decrease the time needed to boot the system |
| System Time:          | [11:07:46]         |             |       |                   |  |
| System Date:          | [09/06/2000]       |             |       |                   |  |
| Legacy Diskette A:    | [1.44/1.25 MB 3½"] |             |       |                   |  |
| Legacy diskette B:    | [Disabled]         |             |       |                   |  |
| # Primary Master      | [1350MB]           |             |       |                   |  |
| # Primary Slave       | [None]             |             |       |                   |  |
| # Secondary Master    | [64MB]             |             |       |                   |  |
| # Keyboard Features   |                    |             |       |                   |  |
| System Memory:        | 640 kB             |             |       |                   |  |
| Extended Memory:      | 64512 kB           |             |       |                   |  |
| Extended Memory:      | 63 MB              |             |       |                   |  |
| # Console Redirection |                    |             |       |                   |  |
| F1 Help               | ↑↓                 | Select Item | -/+   | Change Values     | F9 Setup Defaults  |
| ESC Exit              | ←→                 | Select Menu | Enter | Select # Sub-Menu | F10 Save and Exit  |

## QuickBoot

When enabled, certain checks normally performed during the POST are omitted, decreasing the time required to run the POST. The default is **Enabled**.

## Setting The Time

The time format is based on the 24-hour military-time clock. For example, 1 PM is 13:00:00. Press the left or right arrow key to move the cursor to the desired field (hour, minute, seconds). Press the **PAGE UP** or **PAGE DOWN** key to step through the available choices, or type in the information.

## Setting The Date

Press the left or right arrow key to move the cursor to the desired field (month, day, year). Press the **PAGE UP** or **PAGE DOWN** key to step through the available choices, or type in the information.

## Legacy Diskette

### Floppy Drive A

The VMEbus CPU supports one floppy disk drive. The options are:

- **Disabled**            No diskette drive installed
- **360K, 5.25 in**    5-1/4 inch PC-type standard drive; 360 kilobyte capacity
- **1.2M, 5.25 in**    5-1/4 inch AT-type high-density drive; 1.2 megabyte capacity
- **720K, 3.5 in**      3-1/2 double-sided drive; 720 kilobyte capacity
- **1.44M, 3.5 in**    3-1/2 inch double-sided drive; 1.44 megabyte capacity
- **2.88M, 3.5 in**    3-1/2 inch double-sided drive; 2.88 megabyte capacity

Use **PAGE UP** or **PAGE DOWN** to select the floppy drive. The default is **1.44M, 3.5 inch**.

### Floppy Drive B

The VMEbus CPU does not support a second floppy drive. The default is **Disabled**.

## Primary Master/Slave

The VMEbus CPU has the capability of utilizing one IDE hard disk drive on the Primary Master bus. The default setting is **Auto**. The Primary Slave is assigned to the CD-ROM (if installed).

Figure C-2: Phoenix Primary Master/Slave Drive Menu

| Phoenix Setup Utility  |   |  |
|--|---|--|
| MAIN   |   |  |
| Primary Master [1350]  | Item Specific Help  |  |
| Type: [Auto]   | User = you enter parameters of hard-disk drive installed at this connection.<br>Auto = autotypes hard-drive installed here.<br>1-39 = you select pre-determined type of hard-drive installed here.<br>CD-ROM = a CD-ROM drive is installed here.<br>ATAPI Removable = Removable disk-drive is installed here. |  |
| Cylinders: [2616]  |   |  |
| Heads: [16]  |   |  |
| Sections: [63]   |   |  |
| Maximum Capacity [1350MB]  |   |  |
| Multi-Sector Transfers [16 sectors]  |   |  |
| LBA Mode Control [Enabled]   |   |  |
| 32 Bit I/O [Disabled]  |   |  |
| F1 Help    ↑↓ Select Item    -/+ Change Values    F9 Setup Defaults<br>ESC Exit   ←→ Select Menu    Enter Select # Sub-Menu    F10 Save and Exit |   |  |

## Secondary Master

The Secondary Master is the resident Flash Disk (if installed). The default setting is **Auto**.

## Keyboard Features

The Keyboard Features allows the user to set several keyboard functions.

Figure C-3: Phoenix Keyboard Menu

| Phoenix Setup Utility  |                                     |
|--|-------------------------------------|
| MAIN   |                                     |
| Keyboard Features  | Item Specific Help                  |
| NumLock: [Auto]<br>Key Click: [Disabled]<br>Keyboard Auto-Repeat Rate: [30/sec]<br>Keyboard Auto-Repeat Delay: [1/2 sec]<br>Keyboard Test [Disabled] | Selects Power-on state for NumLock. |
| F1 Help    ↑↓ Select Item    -/+ Change Values    F9 Setup Defaults<br>ESC Exit    ←→ Select Menu    Enter Select # Sub-Menu    F10 Save and Exit    |                                     |

### NumLock

The **NumLock** can be set to **Auto**, **On**, or **Off** to control the state of the **NumLock** key when the system boots. When set to **Auto** or **On**, the numeric keypad generates numbers instead of controlling the cursor operations. The default is **On**.

### Key Click

This option enables or disables the **Keyboard Auto-Repeat Rate** and **Delay** settings. When disabled the values in the Typematic **Rate** and **Delay** are ignored. The default is **Disabled**.

### Keyboard Auto-Repeat Rate (Chars/Sec)

If the **Key Click** is enabled this determines the rate a character is repeated when a key is held down. The options are: **30**, **26.7**, **21.8**, **18.5**, **13.3**, **10**, **6**, or **2** characters per second. The default is **30**.

## Keyboard Auto-Repeat Delay (sec)

If the **Key Click** is enabled this determines the delay before a character starts repeating when a key is held down. The options are: **1/4**, **1/2**, **3/4**, or **1** second. The default is **1/2**.

## Keyboard Test

When enabled this feature will test the keyboard during boot-up.

## System Memory

The **System Memory** field is for informational purposes only and cannot be modified by the user. This field displays the base memory installed in the system.

## Extended Memory

The **Extended Memory** field is for informational purposes only and cannot be modified by the user. This field displays the total amount of memory installed in the system in Kbytes.

## Console Redirection

**Console Redirection** allows for remote access and control of the PC functions to a remote terminal via the serial port. Selecting **Console Redirection** provides additional menus used to configure the console.

Figure C-4: Phoenix Console Redirection Menu

| <b>Phoenix Setup Utility</b>   |                |                                   |                   |                    |  |  |         |                |                   |                   |  |  |          |                |                         |                   |  |  |
|--|----------------|-----------------------------------|-------------------|--------------------|--|--|---------|----------------|-------------------|-------------------|--|--|----------|----------------|-------------------------|-------------------|--|--|
| <b>MAIN</b>  |                |                                   |                   |                    |  |  |         |                |                   |                   |  |  |          |                |                         |                   |  |  |
| Console Redirection  |                |                                   |                   | Item Specific Help |  |  |         |                |                   |                   |  |  |          |                |                         |                   |  |  |
| Com Port Address   | [Disabled]     | If enabled, it will use the port. |                   |                    |  |  |         |                |                   |                   |  |  |          |                |                         |                   |  |  |
| Baud Rate  | [19.2]         |                                   |                   |                    |  |  |         |                |                   |                   |  |  |          |                |                         |                   |  |  |
| Console Type   | [PC ANSI]      |                                   |                   |                    |  |  |         |                |                   |                   |  |  |          |                |                         |                   |  |  |
| Flow Control   | [CTS/RTS]      |                                   |                   |                    |  |  |         |                |                   |                   |  |  |          |                |                         |                   |  |  |
| Console connection:  | [Direct]       |                                   |                   |                    |  |  |         |                |                   |                   |  |  |          |                |                         |                   |  |  |
| Continue C. R. after POST:   | [Off]          |                                   |                   |                    |  |  |         |                |                   |                   |  |  |          |                |                         |                   |  |  |
| <table style="width: 100%; border: none;"> <tr> <td style="width: 12.5%;">F1 Help</td> <td style="width: 12.5%;">↑↓ Select Item</td> <td style="width: 12.5%;">-/+ Change Values</td> <td style="width: 12.5%;">F9 Setup Defaults</td> <td style="width: 12.5%;"></td> <td style="width: 12.5%;"></td> </tr> <tr> <td>ESC Exit</td> <td>←→ Select Menu</td> <td>Enter Select # Sub-Menu</td> <td>F10 Save and Exit</td> <td></td> <td></td> </tr> </table> |                |                                   |                   |                    |  |  | F1 Help | ↑↓ Select Item | -/+ Change Values | F9 Setup Defaults |  |  | ESC Exit | ←→ Select Menu | Enter Select # Sub-Menu | F10 Save and Exit |  |  |
| F1 Help  | ↑↓ Select Item | -/+ Change Values                 | F9 Setup Defaults |                    |  |  |         |                |                   |                   |  |  |          |                |                         |                   |  |  |
| ESC Exit   | ←→ Select Menu | Enter Select # Sub-Menu           | F10 Save and Exit |                    |  |  |         |                |                   |                   |  |  |          |                |                         |                   |  |  |

## Com Port Address

If enabled, it will allow remote access through the serial port. The options are: **Disabled**, **Motherboard Com A**, and **Motherboard Com B**. The default is **Disabled**.

## Baud Rate

Selects a baud rate for the serial port. The options are: **600**, **1200**, **2400**, **4800**, **9600**, **19.2**, **38.4**, and **115.2**. The default is **19.2**.

## Console Type

Selects the type of console to be used. The options are: **PC ANSI** or **VT100**. The default is **PC ANSI**.

## Flow Control

Enables or disables Flow Control. The options are **No Flow Control**, **XON/XOFF**, or **CTS/RTS**. The default is **CTS/RTS**.

## Console Connection

Indicates whether the console is connected directly to the system or if a modem is being used to connect. The options are: **Direct** or **Via Modem**. The default is **Direct**.

## Continue C. R. After POST

This enables console redirection after the operating system has loaded. The options are **OFF** or **ON**. The default setting is **OFF**.

## Advanced Menu

Selecting **Advanced** from the **Main** menu will display the screen shown below.

Figure C-5: Phoenix Advanced Menu

| Phoenix Setup Utility  |          |          |             |   |                   |
|--|----------|----------|-------------|---|-------------------|
| MAIN   | Advanced | Security | Power       | Boot  | Exit              |
| Installed O/S: [Other]<br>Enable ACPI: [No]<br>Reset Configuration Data [No]<br># Cache Memory<br># I/O Device Configuration<br>Large Disk Access Mode: [DOS]<br>Local Bus IDE adapter: [Both]<br>Hard Disk Pre-Delay [30 seconds]<br>Advanced Chipset Control:<br>Clear Watch Dog Timer [Disabled]<br>Stop Boot on FDC Error [Disabled] |          |          |             | Item Specific Help<br>Select the operating system installed on your system which you will use most commonly.<br>Note: An incorrect setting can cause some operating systems to display unexpected behavior. |                   |
| F1   | Help     | ↑↓       | Select Item | -/+   | Change Values     |
| ESC  | Exit     | ←→       | Select Menu | Enter   | Select # Sub-Menu |
|  |          |          | F9          | Setup Defaults  |                   |
|  |          |          | F10         | Save and Exit   |                   |

### Installed O/S

Use this feature to select the operating system to use with your system.

### Enable ACPI

Enable or disable ACPI BIOS (Advance Configuration and Power Interface). Enable for ACPI OS only. The default is **No**.

### Reset Configuration Data

Select **Yes** if you want to clear the extended system configuration data. The default is **No**.

## Cache Memory

Enabling the cache memory enhances the speed of the processor. When the CPU requests data, the system transfers the requested data from the main DRAM into the cache memory where it is stored until processed by the CPU. The default is **Enabled**.

Figure C-6: Phoenix Cache Memory Menu

| Phoenix Setup Utility       |                 |                                     |
|-----------------------------|-----------------|-------------------------------------|
| ADVANCED                    |                 |                                     |
| Cache Memory                |                 | Item Specific Help                  |
| Memory Cache                | [Enabled]       | Sets the state of the memory cache. |
| Cache System BIOS area:     | [Write Protect] |                                     |
| Cache Video BIOS area:      | [Write Protect] |                                     |
| Cache Base 0-512k:          | [Write Back]    |                                     |
| Cache Base 512k-640k:       | [Write Back]    |                                     |
| Cache Extended Memory Area: | [Write Back]    |                                     |
| Cache A000-AFFF:            | [Disabled]      |                                     |
| Cache B000-BFFF:            | [Disabled]      |                                     |
| C800-CBFF:                  | [Disabled]      |                                     |
| CC00-CFFF:                  | [Disabled]      |                                     |
| D000-D3FF:                  | [Disabled]      |                                     |
| D400-D7FF:                  | [Disabled]      |                                     |
| D800-DBFF:                  | [Disabled]      |                                     |
| DC00-DFFF:                  | [Disabled]      |                                     |
| E000-E3FF:                  | [Disabled]      |                                     |

F1 Help    ↑↓ Select Item    -/+ Change Values    F9 Setup Defaults  
 ESC Exit    ←→ Select Menu    Enter Select # Sub-Menu    F10 Save and Exit

## I/O Device Configuration

Select this menu to configure your I/O devices, if required.

Figure C-7: Phoenix I/O Device Configuration Menu

| Phoenix Setup Utility    |                  |                                     |
|--------------------------|------------------|-------------------------------------|
| ADVANCED                 |                  |                                     |
| I/O Device Configuration |                  | Item Specific Help                  |
| Serial port A:           | [Auto]           | Sets the state of the memory cache. |
| Serial port B:           | [Auto]           |                                     |
| Floppy disk controller:  | [Enabled]        |                                     |
| Legacy Diskette A:       | 1.44/1.25 MB 3½" |                                     |

F1 Help    ↑↓ Select Item    -/+ Change Values    F9 Setup Defaults  
 ESC Exit    ←→ Select Menu    Enter Select # Sub-Menu    F10 Save and Exit

## Large Disk Access Mode

The options for the **Large Disk Access Mode** are: **UNIX Novell Netware** or **Other**.

If you are installing new software and the drive fails, change this selection and try again. Different operating systems require different representations of drive geometries. The default is **Other**.

## Local Bus IDE Adapter

This enables or disables the intergrated local bus IDE adapter. The options are: **Disabled**, **Primary**, **Secondary**, or **Both**. The default is **Both**.

## Hard Disk Pre-Delay

This feature adds a delay before the first access of a hard disk by the BIOS. Some hard disks will malfunction if accessed before they have initalized themselves. This delay ensures the hard disk has initialized after power-up, but prior to being accessed. The default is **30 seconds**.

## Advanced Chipset Control

Selecting **Advanced Chipset Control** opens the menu below. Use this menu to change the values in the chipset register for optimizing your system's performance.

Figure C-8: Phoenix Advanced Chipset Control Menu

| Phoenix Setup Utility    |                |  |
|--------------------------|----------------|--|
| ADVANCED                 |                |  |
| Advanced Chipset Control |                | Item Specific Help   |
| Graphics Aperture:       | [64MB]         | Select the size of the Graphics Aperture for the AGP video device. |
| Enable Memory Gap:       | [Disabled]     |  |
| ECC Config:              | [Disabled]     |  |
| SERR Signal Condition    | [Multiple Bit] |  |
| F1 Help                  | ↑↓ Select Item | -/+ Change Values  |
| ESC Exit                 | ←→ Select Menu | Enter Select # Sub-Menu  |
|                          |                | F9 Setup Defaults  |
|                          |                | F10 Save and Exit  |

## Graphics Aperture

Select the size of the graphics aperture for the ACP video device. The options are **4MB**, **8MB**, **16MB**, **64MB**, **128MB**, or **256MB**. The default is **64MB**.

## Enable Memory Map

If enabled, turn system RAM off to free address space for use with an option card. Either a 128KB conventional memory gap, starting at 512KB, or a 1MB extended memory gap, starting at 15MB, will be created in the system RAM. The options are **Disabled**, **Conventional**, or **Extended**. The default is **Disabled**.

## ECC Config

If all memory in the system supports ECC (x72) the ECC Config selects from No ECC (disabled), Checking Only (EC), Checking and Correction (ECC), or Checking, Correction with Scrubbing (ECC Scrub). The default is **Disabled**.

## SERR Signal Configuration

Select ECC error conditions that SERR# will be asserted. The options are: **None**, **Single Bit**, **Multiple Bit**, or **Both**. The default is **Both**.

## Clear Watchdog Timer Reset

This enables or disables clearing of the Watchdog Timer at reset. The default is **Disabled**.

## Stop Boot on FDC Error

When disabled this feature allows the boot process to continue without a floppy drive present. The default is **Disabled**.

# Security

Utilize this screen to set a user password.

Figure C-9: Phoenix Security Menu

| Phoenix Setup Utility   |  |
|---|--|
| Security  |  |
| security  | Item Specific Help   |
| <p>Set Supervisor Password [ Enter ]</p> <div style="border: 1px solid black; padding: 5px; margin: 10px auto; width: fit-content;"> <p>Set Supervisor Password<br/>           Enter New Password [            ]<br/>           Confirm New Password [           ]</p> </div> | <p>Supervisor Password controls Access to the setup utility.</p> |
| <p>F1Help↑↓      Select Item-/+Change Values F9Setup Defaults<br/>           ESCExit←→      Select MenuEnterSelect # Sub-MenuF10Save and Exit</p>   |  |

## Power

This screen, selected from the Main screen, allows the user to configure power saving options on the VMEbus CPU.

Figure C-10: Phoenix Power Menu

| Phoenix Setup Utility          |          |          |             |   |                   |     |                |
|--------------------------------|----------|----------|-------------|---|-------------------|-----|----------------|
| MAIN                           | Advanced | Security | Power       | Boot  | Exit              |     |                |
| Power Savings:                 |          |          | [Disabled]  | Item Specific Help  |                   |     |                |
| CPU Throttling Down Threshold  |          |          | [50 C]      | Maximum Power savings conserves the greatest amount of system power. Maximum Performance conserves power but allows greatest system performance. To alter these settings, choose Customized. To turn off power management, choose Disabled. |                   |     |                |
| CPU Throttling Back Hysteresis |          |          | [5 C]       |   |                   |     |                |
| CPU Clock Duty Cycle           |          |          | [50 %]      |   |                   |     |                |
| Standby Timeout:               |          |          | [Off]       |   |                   |     |                |
| Auto Suspend Timeout:          |          |          | [Off]       |   |                   |     |                |
| IDE Drive 0 Monitoring:        |          |          | [Disabled]  |   |                   |     |                |
| IDE Drive 1 Monitoring:        |          |          | [Disabled]  |   |                   |     |                |
| IDE Drive 2 Monitoring:        |          |          | [Disabled]  |   |                   |     |                |
| IDE Drive 3 Monitoring:        |          |          | [Disabled]  |   |                   |     |                |
| PCI Bus Monitoring:            |          |          | [Disabled]  |   |                   |     |                |
| F1                             | Help     | ↑↓       | Select Item | -/+   | Change Values     | F9  | Setup Defaults |
| ESC                            | Exit     | ←→       | Select Menu | Enter   | Select # Sub-Menu | F10 | Save and Exit  |

## Boot Menu

The Boot priority is determined by the stack order, with the top having the highest priority and the bottom the least. The order can be modified by highlighting a device and, using the + or - keys, moving it to the desired order in the stack. A device can be boot disabled by highlighting the particular device and pressing **SHIFT + 1**. **ENTER** expands or collapses devices with a + or - next to them.

Figure C-11: Phoenix Boot Menu

| Phoenix Setup Utility   |          |          |             |  |                   |     |                |
|---|----------|----------|-------------|--|-------------------|-----|----------------|
| MAIN  | Advanced | Security | Power       | Boot   | Exit              |     |                |
| + Removable Devices:<br>+ Hard Drive<br>ATAPI CD-ROM Drive<br>Managed PC Boot Agent (MBA) |          |          |             | Item Specific Help<br><br>Keys used to view or<br>configure devices:<br><Enter> expands or<br>collapses devices with<br>a + or -<br><Ctrl + Enter> expands<br>all<br><Shift + 1> enables or<br>disables a device.<br><+> and <-> moves the<br>device up or down.<br><n> may move removable<br>device between Hard<br>Disk or Removable Disk<br><d> remove a device<br>that is not installed. |                   |     |                |
| F1  | Help     | ↑↓       | Select Item | -/+  | Change Values     | F9  | Setup Defaults |
| ESC   | Exit     | ←→       | Select Menu | Enter  | Select # Sub-Menu | F10 | Save and Exit  |

## Exit Menu

The **Exit** menu allows the user to exit the BIOS program, while either saving or discarding any changes. This menu also allows the user to restore the BIOS defaults if desired.

Figure C-12: Phoenix Exit Menu

| Phoenix Setup Utility  |          |          |             |       |  |
|--|----------|----------|-------------|-------|--|
| MAIN   | Advanced | Security | Power       | Boot  | Exit   |
| Exit Saving Changes<br>Exit Discarding Changes<br>Load setup Defaults<br>Discard Changes<br>Save Changes |          |          |             |       | Item Specific Help<br>Exit system Setup and<br>save your changes to<br>CMOS. |
| F1   | Help     | ↑↓       | Select Item | -/+   | Change values  |
| ESC  | Exit     | ←→       | Select Menu | Enter | Select # Sub-Menu  |
|  |          |          |             | F9    | Setup Defaults   |
|  |          |          |             | F10   | Save and Exit  |

### Exit Saving Changes

Exit System Setup and save your changes to CMOS.

### Exit Discarding Changes

Exit System Setup, discarding any changes to CMOS.

### Load Setup Defaults

Load System defaults as defined at the factory.

## Discard Changes

Discard any changes without exiting the setup program.

## Save Changes

Save any changes made without exiting the setup program.

This appendix provides the user with the information needed to develop custom applications for the VMEbus CPU. The CPU board on the VMEbus CPU is unique in that the BIOS cannot be removed; it must be used in the initial boot cycle. A custom application, like a revised operating system for example, can only begin to operate after the BIOS has finished initializing the CPU. The VMEbus CPU will allow the user to either maintain the current BIOS configuration or alter this configuration to be more user specific, but this alteration can only be accomplished after the initial BIOS boot cycle has completed.

This appendix is divided into the following sections:

- BIOS Operations
- Device Address Definition
- Device Interrupt Definition

## *BIOS Operations*

When the VMEbus CPU is powered on, control immediately jumps to the BIOS. The BIOS initiates a Power-on Self-Test (POST) program, which instructs the microprocessor to initialize system memory as well as the rest of the system. The BIOS establishes the configuration of all on-board devices by initializing their respective

I/O and Memory addresses and interrupt request lines. The BIOS then builds an interrupt vector table in main memory, which is used for interrupt handling. The default interrupt vector table and the default address map are described in Chapter 3 of this manual. Finally, the BIOS jumps to the hard drive or floppy drive to execute the operating system's boot program. This is the point at which a custom operating system may take control of the board and proceed with a custom configuration and/or custom application. A user application may override the configuration set by the BIOS and reconfigure the system or it may accept what the BIOS initialized.

## **BIOS Control Overview**

There are two areas on the VMEbus CPU in which the user must be familiar in order to override the initial BIOS configuration. These include the device addresses and the device interrupts. This appendix reviews the details of these addresses and interrupts, and provides a reference list for the individual devices used on the board.

The VMEbus CPU utilizes the high-performance Peripheral Component Interconnect (PCI) bus along with the Industrial Standard Architecture (ISA) bus. In general, the PCI bus is plug-and-play compatible. The components that are connected to the PCI bus are not always placed at a standard I/O or Memory address, nor are they connected to a standard interrupt request line as is the case with ISA bus devices. These PCI bus devices are re-established by the BIOS, meaning that these devices will not always be located at the same address or connected to the same interrupt request line every time the CPU is booted. This appendix lists the defaults that are found by powering up a specific VMEbus CPU.

## **Functional Overview**

The block diagram included in Figure D-1 on page 109 illustrates the VMEbus CPU emphasizing the I/O features, including the PCI-to-VMEbus bridge.

The circled number in the upper left corner of a function block references the appropriate data book necessary for the programming of the function block.

Figure D-1: VMEbus CPU Block Diagram

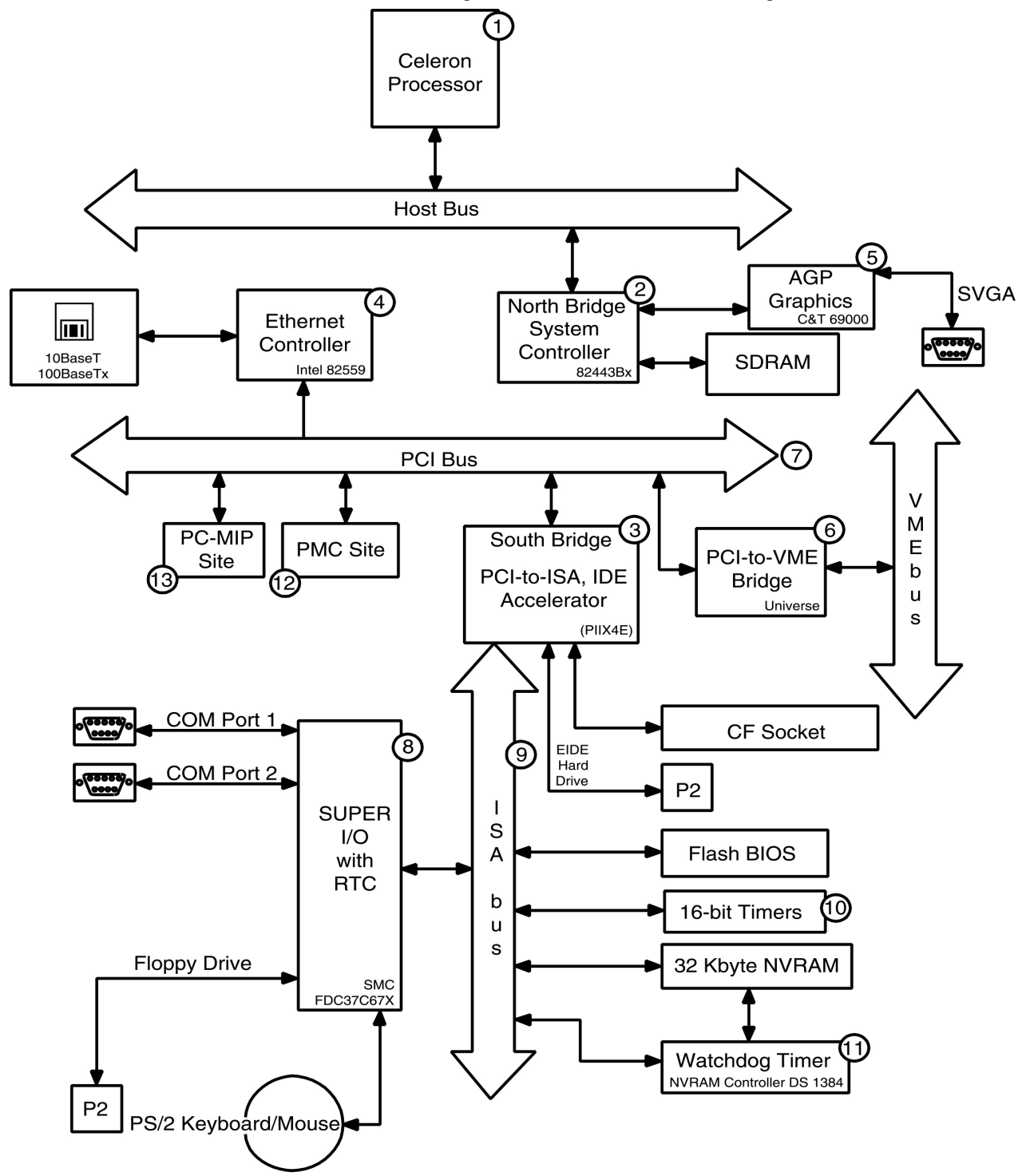

## Data Book References

1. Celeron Processor Developer's Manual  
Order Number 241428  
Intel Corporation  
2200 Mission College Blvd.  
P.O. Box 58119  
Santa Clara, CA 95052-8119  
(408) 765-8080  
[www.intel.com](http://www.intel.com)
2. Intel 440BX PCISet 82443BX Host Bridge/Controller  
Intel Corporation  
2200 Mission College Blvd.  
P.O. Box 58119  
Santa Clara, CA 95052-8119
3. Intel PIIX4E  
82371EB PCI ISA IDE Xcellerator (PIIX4E)  
2200 Mission College Blvd.  
P.O. Box 58119  
Santa Clara, CA 95052-8119
4. Intel 82559 10/100 Mb/s Ethernet LAN Controller  
Intel  
[www.intel.com](http://www.intel.com)
5. Intel 69000 Technical Reference Manual  
Intel Corporation  
2200 Mission College Blvd.  
P.O. Box 58119  
Santa Clara, CA 95052-8119  
(408) 765-8080  
[www.intel.com](http://www.intel.com)
6. Tundra Universe II-Based VMEbus Interface  
User's Manual, GFK-2122
7. PCI Local Bus Specification, Rev. 2.1  
PCI Special Interest Group (PCI-SIG)  
5440 SW Westgate Dr., No. 217  
Portland, OR 97221  
Phone: 503-291-2569  
FAX: 503-297-1090  
[www.pcisig.com](http://www.pcisig.com)

8. SMC FDC37C67X Enhanced Super I/O Controller  
SMC Component Products Division  
350 Kennedy Dr.  
Hauppauge, NY 11788  
Phone: (516) 435-6000  
FAX: (516) 273-1803 (FAX)  
www.smc.com
  
9. ISA & EISA, Theory and Operation  
Solari, Edward  
Annabooks  
15010 Avenue of Science, Suite 101  
San Diego, CA 92128 USA  
www.annabooks.com  
ISBN 0-929392 -15-9  
82C54 CHMOS Programmable Internal Timer
  
10. Intel Corporation  
2200 Mission College Blvd.  
P.O. Box 58119  
Santa Clara, CA 95052-8119
  
11. DS 1384 Watchdog Timekeeping Controller  
Dallas Semiconductor  
4461 South Beltwood Pwky  
Dallas, TX 75244-3292
  
12. IEEE P1386 PMC Specification  
The Institute of Electrical and Electronics Engineers, Inc.  
1828 L Street, N.W., Suite 1202  
Washington, D.C. 20036-5104  
(202) 785 0017  
www.ieee.com
  
13. Vita 29 Draft 0.92b PC-MIP Specification  
Vita Standards Organization  
7825 East Gelding Dr.  
Suite 104  
Scottsdale, AZ 85260  
Phone: (480) 951-8866  
FAX: (480) 951-0720  
www.vita.com

## Device Address Definition

The standard PC/AT architecture defines two distinctive types of address spaces for the devices and peripherals on the CPU board. These spaces have typically been named Memory address space and I/O address space. The boundaries for these areas are limited to the number of address bus lines that are physically located on the CPU board. The VMEbus CPU has 32 address bus lines located on the board, thereby defining the limit of the address space as 4 Gbyte. The standard PC/AT architecture defines Memory address space from zero to 4 Gbyte and the separate I/O address space from zero to 64 Kbyte.

## ISA Devices

The ISA devices on the VMEbus CPU are configured by the BIOS at boot-up and adhere to the standard PC/AT architecture. They are mapped in I/O address space within standard addresses and their interrupts are mapped to standard interrupt control registers. However, all of the ISA devices with the exception of the real-time clock, keyboard, and programmable timer are relocatable to almost anywhere within the standard 1 Kbyte of I/O address space. Table D-1 defines the spectrum of addresses available for reconfiguration of ISA devices.

As previously stated, in the standard PC/AT system, all I/O devices are mapped in I/O address space. On the VMEbus CPU, however, the Dynamic Random Access Memory (DRAM), Battery-Backed SRAM, and Watchdog Timer are addressed in Memory address space. The BIOS places DRAM at address zero and extends to the physical limit of the on-board DRAM.

**Table D-1: ISA Device Mapping Configuration**

| Device                             | Memory Space              | I/O Address Space  | PIC Interrupt Options | Byte Address Boundary | Default |
|------------------------------------|---------------------------|--|-----------------------|-----------------------|---------|
| Floppy                             | N/A                       | [0x100 - 0xFF8]  | IRQ1 - IRQ15          | 8                     | \$3F0   |
| Serial Port 1                      | N/A                       | [0x100 - 0xFF8]  | IRQ1 - IRQ15          | 8                     | \$3F8   |
| Serial Port 2                      | N/A                       | [0x100 - 0xFF8]  | IRQ1 - IRQ15          | 8                     | \$2F8   |
| Real-Time Clock                    | Nonrelocatable            |  |                       |                       | \$070   |
| Keyboard                           | Nonrelocatable            |  |                       |                       | \$060   |
| Auxiliary I/O                      | N/A                       | - Primary I/O<br>[0x000 - 0xFFF]<br>- Secondary I/O<br>[0x000 - 0xFFF] | IRQ1,<br>IRQ3-IRQ15   | 1<br>1                |         |
| Programmable Timer                 |                           | Nonrelocatable<br>0x500  | IRQ5                  | 4                     | 0x500   |
| Battery-Backed SRAM                | Nonrelocatable<br>0xD8018 | N/A  | N/A                   | (32K-0x18)            | 0xD8018 |
| Board ID Register                  | Nonrelocatable            |  |                       |                       |         |
| 0xD8016                            | N/A                       | N/A  | 2                     |                       |         |
| VME BERR Address Modifier Register | Nonrelocatable<br>0xD8014 | N/A  | N/A                   | 2                     |         |

| Device                    | Memory Space              | I/O Address Space | PIC Interrupt Options | Byte Address Boundary | Default |
|---------------------------|---------------------------|-------------------|-----------------------|-----------------------|---------|
| VME BERR Address Register | Nonrelocatable<br>0xD8010 | N/A               |                       | 4                     |         |
| System Command Register   | Nonrelocatable<br>0xD800E | N/A               |                       | 2                     |         |
| Watchdog Timer            | Nonrelocatable<br>0xD8000 | N/A               | N/A                   | 0xD                   | 0xD8000 |

## PCI Devices

PCI devices are fully configured under I/O and/or Memory address space. Table D-2 describes the PCI bus devices that are on-board the VMEbus CPU along with each device’s configuration spectrum.

The PCI bus includes three physical address spaces. As with ISA bus, PCI bus supports Memory and I/O address space, but PCI bus includes an additional Configuration address space. This address space is defined to support PCI bus hardware configuration (refer to the PCI bus Specification for complete details on the configuration address space). PCI bus targets are required to implement Base Address registers in configuration address space to access internal registers or functions. The BIOS uses the Base Address register to determine how much space a device requires in a given address space and then assigns where in that space the device will reside. This functionality enables PCI devices to be located in either Memory or I/O address space.

**Table D-2: PCI Device Mapping Configuration**

| Device                                | Memory Space | I/O Address Space | PIC Interrupt Options |
|---------------------------------------|--------------|-------------------|-----------------------|
| SVGA                                  | Anywhere     | N/A               | N/A                   |
| Universe II**<br>PCI-to-VMEbus Bridge | Anywhere     | N/A               | PCI Defined           |
| Ethernet                              | Anywhere     | Anywhere          | PCI Defined           |
| Timer Interrupt Registers             | N/A          | Fixed             | N/A                   |
| PC-MIP                                | Anywhere     | Anywhere          | PCI Defined           |
| PMC Site                              | Anywhere     | Anywhere          | PCI Defined           |

\*\* Refer to the GFK-2122 manual for more information.

---

## *Device Interrupt Definition*

### **PC/AT Interrupt Definition**

The interrupt hardware implementation on the VMEbus CPU is standard for computers built around the PC/AT architecture. The PC/AT evolved from the IBM PC/XT architecture. In the IBM PC/XT systems, only eight Interrupt Request (IRQ) lines exist, numbered from IRQ0 to IRQ7. These interrupt lines were included originally on a 8259A Priority Interrupt Controller (PIC) chip.

The IBM PC/AT computer added eight more IRQx lines, numbered IRQ8 to IRQ15, by cascading a second slave 8259A PIC into the original master 8259A PIC. The interrupt line IRQ2 at the master PIC was committed as the cascade input from the slave PIC. This master/slave architecture, the standard PC/AT interrupt mapping, is illustrated in Figure D-2 on page 115 within the PCI-to-ISA Bridge PIIX4E 82371EB section of the diagram.

To maintain backward compatibility with PC/XT systems, IBM chose to use the new IRQ9 input on the slave PIC to operate as the old IRQ2 interrupt line on the PC/XT Expansion Bus. Thus, in AT systems, the IRQ9 interrupt line connects to the old IRQ2 pin on the AT Expansion Bus (or ISA bus).

The BIOS defines the PC/AT interrupt line to be used by each device. The BIOS writes to each of the two cascaded 8259A PIC chips an 8-bit vector, which maps each IRQx to its corresponding interrupt vector in memory.

### **ISA Device Interrupt Map**

The VMEbus CPU BIOS maps the IRQx lines to the appropriate device per the standard ISA architecture. Reference Figure D-2 on page 115. This initialization operation cannot be changed; however, a custom application could reroute the interrupt configuration after the BIOS has completed the initial configuration cycle.

Figure D-2: BIOS Default Connections for the PC Interrupt Logic Controller

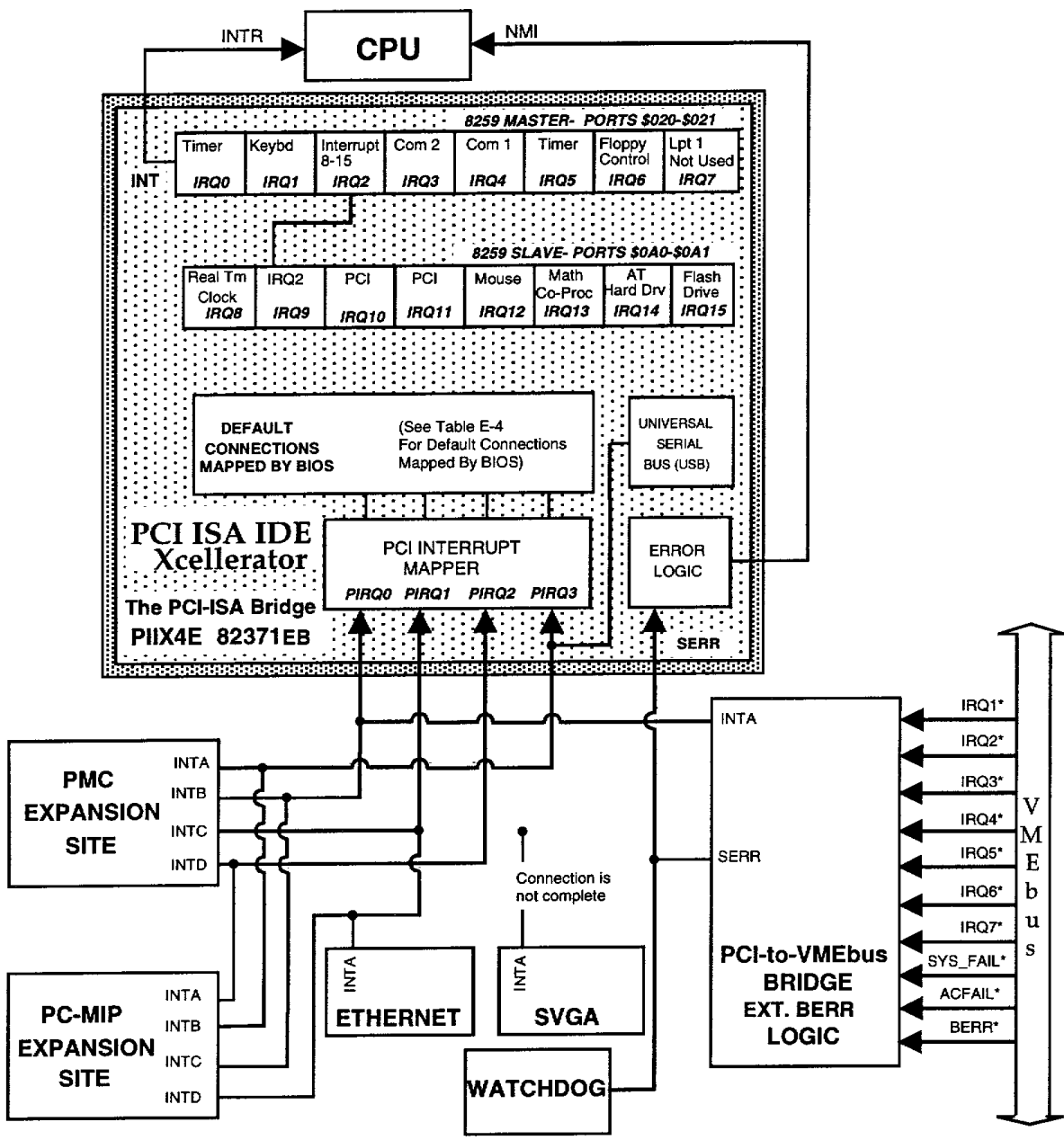

## PCI Device Interrupt Map

The PCI bus-based external devices include the two PCI expansion sites, the PCI-to-VMEbus bridge, and the VGA reserved connection. The default BIOS maps these external devices to the PCI Interrupt Request (PIRQ<sub>x</sub>) lines of the PIIX4E. This mapping is illustrated in Figure D-2 on page 115 and is defined in Table D-3.

The device PCI interrupt lines (INTA through INTD) that are present on each device cannot be modified.

**Table D-3: Device PCI Interrupt Mapping by the BIOS**

| Device  | Component                  | Vendor ID      | Device ID      | CPU Address Map ID Select | Device PCI Interrupt | Motherboard PCI Interrupt Mapper | Data Book Ref. # | Revision ID |
|---|----------------------------|----------------|----------------|---------------------------|----------------------|----------------------------------|------------------|-------------|
| PCI-to-VME Bridge Option: Tundra Universe II™ | Universe CA91C142          | 0x10E3         | 0x0            | AD19                      | INTA                 | PIRQ0                            | 6                | N/A         |
| PCI Expansion Site                            | N/A                        | Board Specific | Board Specific | N/A                       | INTA                 | PIRQ3                            | N/A              | N/A         |
|   | N/A                        | N/A            | Board Specific | Board Specific            | N/A                  | INTB                             | PIRQ0            | N/A         |
|   | N/A                        | Board Specific | Board Specific | N/A                       | INTC                 | PIRQ1                            | N/A              | N/A         |
|   | N/A                        | Board Specific | Board Specific | N/A                       | INTD                 | PIRQ2                            | N/A              | N/A         |
| PC-MIP  | N/A                        | Board Specific | Board Specific | N/A                       | INTA                 | PIRQ2                            | N/A              | N/A         |
| xx  | N/A                        | Board Specific | Board Specific | N/A                       | INTB                 | PIRQ3                            | N/A              | N/A         |
| xx  | N/A                        | Board Specific | Board Specific | N/A                       | INTC                 | PIRQ0                            | N/A              | N/A         |
| xx  | N/A                        | Board Specific | Board Specific | N/A                       | INTD                 | PIRQ1                            | N/A              | N/A         |
| Power Management                              | PIIX4E 82371AB Function 03 | 0x8086         | 0x7113         | AD18                      | N/A                  | N/A                              | 3                | N/A         |
| PCI-to-ISA Bridge                             | PIIX4E 82371AB Function 00 | 0x8086         | 0x7110         | AD18                      | N/A                  | N/A                              | 3                | N/A         |
| SVGA Controller                               | Intel 69000                | 0x102C         | 0x0DC0         | AD16                      | INTA**               | PIRQ3**                          | 5                | N/A         |
| Ethernet Controller                           | Intel 88559                | 0x8086         | 0x1229         | AD20                      | INTA                 | PIRQ2                            | 4                | N/A         |
| PCI IDE Controller                            | PIIX4E 82371AB Function 01 | 0x8086         | 0x7111         | AD18                      | N/A                  | N/A                              | 3                | N/A         |

| Device                        | Component                        | Vendor ID | Device ID | CPU Address Map ID Select | Device PCI Interrupt | Motherboard PCI Interrupt Mapper | Data Book Ref. # | Revision ID |
|-------------------------------|----------------------------------|-----------|-----------|---------------------------|----------------------|----------------------------------|------------------|-------------|
| Universal Serial Bus (USB)*** | PIIX4E<br>82371AB<br>Function 02 | 0x8086    | 0x7112    | AD18                      | INTD                 | PIRQ3                            | 3                | N/A         |
| PCI Host Bridge               | Intel 440BX                      | 0x8086    | 0x7190    | N/A                       | N/A                  | N/A                              | 2                | N/A         |
| PCI to AGP Bridge             | Intel 440BX                      | 0x8086    | 0x7191    | N/A                       | N/A                  | N/A                              | 2                | N/A         |

\* To access these parts, use the revision number as the distinguishing factor.

\*\* Not connected, for reference only

\*\*\* PIRQ4 interrupt is not enabled by the BIOS.

The motherboard accepts these PCI device interrupts through the PCI interrupt mapper function. The BIOS default maps the PCI Interrupt Request (PIRQx) external device lines to one of the available slave PIC Interrupt Request lines, IRQ (9, 10, 11, 12, 14, or 15).

This appendix provides listings of a library of sample code that the programmer may utilize to build applications. These files are provided to the VMEbus CPU user on disk **320-500037-006**, Sample Application C Code for the IC697VSC096, included in the distribution disk set.

Because of the wide variety of environments in which the VMEbus CPU operates, the samples provided in this appendix are not intended to be used verbatim. Rather, they are intended to provide the end user an example of the standard structure of the operating code.

This appendix is divided into the following sections:

- Directory CPU
- Directory SRAM
- Directory Timers
- Directory WATCHDOG

## Directory CPU

The code under the CPU directory sets up the universe chip with one PCI-TO-VME window and enables universe registers to be accessed from VME to allow mailbox access.

Because of the wide variety of environments in which the VMEbus CPU operates, the samples provided in this appendix are not intended to be used verbatim. Rather, they are intended to provide the end user an example of the standard structure of the operating code.

## CPU.C

```

/*****
/* FILE: CPU.C
/*
/* Setup the universe chip with one PCI-TO-VME window and enable universe
/* registers to be accessed from VME to allow mailbox access.
/*
/*
*****/
#include <stdlib.h>
#include <stdio.h>
#include <string.h>
#include <conio.h>
#include <ctype.h>
#include <dos.h>
#include "flat.h"
#include "pci.h"
#include "universe.h"
#include "cpu.h"
#define PCI_BASE16 0x10000000 /* PCI BASE for A16 */
#define VME_16_RA 0x0000C000 /* VME BASE for A16 REG ACCESS */
#define IRQ9 0x71 /* Int. No. for hardware int 9 */
#define IRQA 0x72 /* Int. No. for hardware int A */
#define IRQB 0x73 /* Int. No. for hardware int B */
#define IRQC 0x74 /* Int. No. for hardware int C */
#define IRQD 0x75 /* Int. No. for hardware int D */
#define IRQE 0x76 /* Int. No. for hardware int E */
#define IRQF 0x77 /* Int. No. for hardware int F */
/* function prototypes */
void far interrupt irq_rcvd( void );
void init_int( void );
void restore_orig_int( void );
void do_exit( int );
/* global variables */
unsigned char pic2_org;
unsigned long mb0_msg;
unsigned long mb1_msg;
unsigned long mb2_msg;
unsigned long mb3_msg;
unsigned long int_status;
void far interrupt (* old_vect)(void);
unsigned char int_line;
char user[80];
FPTR un_regs;
void main( void )
{
    unsigned char pci_devices;
    int test_int, to_cnt;
    unsigned long temp_dword;
    unsigned char bus, dev_func;
    printf("\n\n");
    /* try to locate the UNIVERSE device on the PCI bus */
    test_int = find_pci_device(UNIVERSE_DID, UNIVERSE_VID, 0,
        &bus, &dev_func);
    if(test_int == SUCCESSFUL)
    {
        test_int = read_configuration_area(READ_CONFIG_DWORD, bus, dev_func,
            0x10, &temp_dword);
        if(test_int == SUCCESSFUL)

```

```

    {
        un_regs = (FPTR) temp_dword;
    }
    else
    {
        printf("Unable to read configuration area 0x10\n");
        exit(1);
    }
}
else
{
    printf("Unable to locate PCI device Tundra Universe\n");
    exit(1);
}
test_int = read_configuration_area(READ_CONFIG_BYTE, bus, dev_func,
                                  0x3C, &temp_dword);
if(test_int == SUCCESSFUL)
{
    int_line = temp_dword & 0xFF;
}
else
{
    printf("Unable to read configuration area 0x3C\n");
    exit(1);
}
/* setup protected mode */
extend_seg();
a20(1);
mb0_msg = 0;
mb1_msg = 0;
mb2_msg = 0;
mb3_msg = 0;
init_int();
/* 32K PCI slave window at 0x10000000 to VME A16 0x0000 user data */
fw_long(un_regs + LSI0_BS_A, PCI_BASE16); /* pci base for A16 */
fw_long(un_regs + LSI0_BD_A, (PCI_BASE16 + 0x8000)); /* 32K window */
fw_long(un_regs + LSI0_TO_A, (0x00000000 - PCI_BASE16));
fw_long(un_regs + LSI0_CTL_A, (LSI_CTL_EN | LSI_CTL_VDW_32 | LSI_CTL_VAS_16));
/* enable 4K VME to universe regs @ sht I/O 0xC000 to allow mailbox access */
fw_long(un_regs + VRAI_BS_A, VME_16_RA);
fw_long(un_regs + VRAI_CTL_A, (VRAI_CTL_EN | VRAI_CTL_AM_D |
                              VRAI_CTL_AM_US | VRAI_CTL_VAS_16));
/* enable VME with master & slave set for big endian and time out 64 us */
fw_word(CPUREGS, (VME_EN | MEC_BE | SEC_BE | BYPASS_EN | BTO_64 | BTO_EN));
/* place additional code here */
do_exit(0);
} /* end main */
void do_exit(int xcode)
{
    /* disable all windows and ints */
    fw_long(un_regs + LSI0_CTL_A, 0);
    fw_long(un_regs + LSI1_CTL_A, 0);
    fw_long(un_regs + LSI2_CTL_A, 0);
    fw_long(un_regs + LSI3_CTL_A, 0);
    fw_long(un_regs + LSI4_CTL_A, 0);
    fw_long(un_regs + LSI5_CTL_A, 0);
    fw_long(un_regs + LSI6_CTL_A, 0);
    fw_long(un_regs + LSI7_CTL_A, 0);
    fw_long(un_regs + VSI0_CTL_A, 0);
    fw_long(un_regs + VSI1_CTL_A, 0);
    fw_long(un_regs + VSI2_CTL_A, 0);
    fw_long(un_regs + VSI3_CTL_A, 0);
    fw_long(un_regs + VSI4_CTL_A, 0);
    fw_long(un_regs + VSI5_CTL_A, 0);
    fw_long(un_regs + VSI6_CTL_A, 0);
    fw_long(un_regs + VSI7_CTL_A, 0);
    fw_long(un_regs + SLSI_A, 0);
    fw_long(un_regs + VRAI_CTL_A, 0);
    fw_long(un_regs + LINT_EN_A, 0);
    fw_word(CPUREGS, 0);
    restore_orig_int( );
    a20(0);
    exit(xcode);
} /* end do_exit */

```

```

/*****
/* init_int()
/*
/* purpose: Using the interrupt assigned, the original vector is */
/*           saved and the vector to the new ISR is installed. The */
/*           programmable-interrupt-controller (PIC) is enabled. */
/*
/*****
/* parameters: none
/*****
/* return value: none
/*****
void init_int(void)
{
  disable();
  /* Read 8259 slave Programmable Interrupt controller */
  pic2_org = inp(0xal) & 0xFF; /* slave mask bits */
  switch(int_line)
  {
    case 0x9:
      old_vect = getvect(IRQ9); /* save vector for IRQ 09 */
      setvect(IRQ9, irq_rcvd);
      /* enable interrupt 9 */
      outp(0xal, (pic2_org & 0xFD));
      break;
    case 0xa:
      old_vect = getvect(IRQA); /* save vector for IRQ 10 */
      setvect(IRQA, irq_rcvd);
      /* enable interrupt 10 */
      outp(0xal, (pic2_org & 0xFB));
      break;
    case 0xb:
      old_vect = getvect(IRQB); /* save vector for IRQ 11 */
      setvect(IRQB, irq_rcvd);
      /* enable interrupt 11 */
      outp(0xal, (pic2_org & 0xF7));
      break;
    case 0xc:
      old_vect = getvect(IRQC); /* save vector for IRQ 12 */
      setvect(IRQC, irq_rcvd);
      /* enable interrupt 12 */
      outp(0xal, (pic2_org & 0xEF));
      break;
    case 0xd:
      old_vect = getvect(IRQD); /* save vector for IRQ 13 */
      setvect(IRQD, irq_rcvd);
      /* enable interrupt 13 */
      outp(0xal, (pic2_org & 0xDF));
      break;
    case 0xe:
      old_vect = getvect(IRQE); /* save vector for IRQ 14 */
      setvect(IRQE, irq_rcvd);
      /* enable interrupt 14 */
      outp(0xal, (pic2_org & 0xBF));
      break;
    case 0xf:
      old_vect = getvect(IRQF); /* save vector for IRQ 15 */
      setvect(IRQF, irq_rcvd);
      /* enable interrupt 15 */
      outp(0xal, (pic2_org & 0x7F));
      break;
  } /* end switch */
  fw_long(un_regs + LINT_STAT_A, 0xFFF7FF); /* clear any previous status bits */
  fw_long(un_regs + LINT_MAP0_A, 0); /* map all VME ints to lint#0 INTA */
  fw_long(un_regs + LINT_MAP1_A, 0); /* map all ERR/STAT ints to lint#0 INTA */
  fw_long(un_regs + LINT_MAP2_A, 0); /* map all MB/LM ints to lint#0 INTA */
  /* enable mailbox 0 ints only */
  fw_long(un_regs + LINT_EN_A, LINT_EN_MBOX0);
  int_status = 0;
  enable();
} /* init_int */

```

```

/*****
/* restore_orig_int()
/*
/* purpose: Using the interrupt assigned, the original vector is
/*           restored and the programmable-interrupt-controller
/*           is restored to its original settings.
/*
/* Prerequisite: The interrupt line to be used must have
/*               already been loaded in the global variable.
/*
/*****
/* parameters: none
/*****
/* return value: none
/*****
void restore_orig_int(void)
{
    disable();
    outp(0xal, pic2_org);
    switch( int_line )
    {
        case 0x9:
            setvect( IRQ9, old_vect );
            break;
        case 0xa:
            setvect( IRQA, old_vect );
            break;
        case 0xb:
            setvect( IRQB, old_vect );
            break;
        case 0xc:
            setvect( IRQC, old_vect );
            break;
        case 0xd:
            setvect( IRQD, old_vect );
            break;
        case 0xe:
            setvect( IRQE, old_vect );
            break;
        case 0xf:
            setvect( IRQF, old_vect );
            break;
    } /* end switch */
    fw_long( un_regs + LINT_EN_A, 0 ); /* disable all interrupts */
    enable();
} /* restore_orig_int */

/*****
/* irq_rcvd()
/*
/* purpose: Interrupt service routine. (INTA handler)
/*
/*****
/* parameters: none
/*****
/* return value: none
/*****
void interrupt irq_rcvd( void )
{
    unsigned long lint_enable, tmp_status;
    disable();
    asm {
        .386P
        push    eax
        push    ebx
    }
    int_status = fr_long( un_regs + LINT_STAT_A ); /* read interrupt status */
    fw_long( un_regs + LINT_STAT_A, int_status ); /* clear status */
    /* check for mailbox interrupt */
    if( int_status & LINT_STAT_MBOX0 )
    {
        mb0_msg = fr_long( un_regs + MBOX0_A );
    }
    if( int_status & LINT_STAT_MBOX1 )
    {
        mb1_msg = fr_long( un_regs + MBOX1_A );
    }
    if( int_status & LINT_STAT_MBOX2 )

```

```
{
    mb2_msg = fr_long( un_regs + MBOX2_A );
}
if( int_status & LINT_STAT_MBOX3 )
{
    mb3_msg = fr_long( un_regs + MBOX3_A );
}
/* disable MB ints */
lint_enable = fr_long( un_regs + LINT_EN_A );
lint_enable &= ~(LINT_EN_MBOX3 | LINT_EN_MBOX2 |
                LINT_EN_MBOX1 | LINT_EN_MBOX0);
fw_long( un_regs + LINT_EN_A, lint_enable );
/* clear all mailboxes */
fw_long( un_regs + MBOX0_A, 0 );
fw_long( un_regs + MBOX1_A, 0 );
fw_long( un_regs + MBOX2_A, 0 );
fw_long( un_regs + MBOX3_A, 0 );
tmp_status = fr_long( un_regs + LINT_STAT_A ); /* read interrupt status */
fw_long( un_regs + LINT_STAT_A, tmp_status ); /* clear status */
/* re-enable MB0 ints */
lint_enable |= LINT_EN_MBOX0;
fw_long( un_regs + LINT_EN_A, lint_enable );
/* Non specific end of interrupt to master & slave PIC */
outp(0x20, 0x20); /* Master end of irq command */
outp(0xa0, 0x20); /* Slave end of irq command */
asm {
    .386P
    pop    ebx
    pop    eax
}
enable();
}
```

**\*\* FILE: CPU.H**

```
typedef unsigned char  Byte;
typedef unsigned short Word;
typedef unsigned long  Long;
/* universe Device ID and Vendor ID */
#define UNIVERSE_VID    0x10E3
#define UNIVERSE_DID    0x0000
/* CPU specific bits located at I/O 0x400 */
#define CPUREGS         0xD800E /* CPU regs located at mem 0xD800E */
#define MEC_BE          0x0001 /* master endian conversion big endian */
#define MEC_LE          0x0000 /* master endian conversion little endian */
#define SEC_BE          0x0002 /* slave endian conversion big endian */
#define SEC_LE          0x0000 /* slave endian conversion little endian */
#define BERR_LATCH_EN  0x0004 /* buss error latch enable */
#define BTO_EN          0x0008 /* bus timeout timer enable */
#define BTO_16          0x0000 /* bus timeout 16 us */
#define BTO_64          0x0010 /* bus timeout 64 us */
#define BTO_256         0x0020 /* bus timeout 256 us */
#define BTO_1MS         0x0030 /* bus timeout 1 ms */
#define BERR_INT_EN     0x0040 /* bus error interrupt enable */
#define BERR_STAT_CLR   0x0080 /* buss error status/clear R/W1C */
#define WD_SYSFAIL      0x0100 /* watchdog to VME sysfail enable */
#define BYPASS_EN       0x0400 /* bypass enable - MEC/SEC must be LE */
#define VME_EN          0x0800 /* vme bus enable */
```

## \*\* FILE: FLAT.C

```

/*
** flat.c
**
** Access flat memory space (up to 4GB) in real mode.
**
*/
#include <stdio.h>
#include <dos.h>
#include "flat.h"
/*
** Keyboard controller defines
*/
#define RAMPORT 0x70
#define KB_PORT 0x64
#define PCNMIPORT 0xA0
#define INBA20 0x60
#define INBA200N 0xDF
#define INBA200FF 0xDD
/*
** macro to clear keyboard port
*/
#define kx() { while( inp( KB_PORT ) & 2 ); }
/*
** define local Global Descriptor Table (GDT) pointer structure
*/
static struct fword gdtptr; /* fword ptr to gdt */
/*
** A20: Enable A20 line
**
** flag: enable = 1
**       disable = 0
*/
void a20( int flag )
{
    kx();
    outp( KB_PORT, 0xD1 );
    kx();
    outp( INBA20, flag ? INBA200N : INBA200FF );
    kx();
    outp( KB_PORT, 0xFF );
    kx();
}
/*
** convert a linear address to a far pointer
*/
void far * linear_to_seg( FPTR lin )
{
    void far *p;
    FP_SEG(p) = (unsigned int)( lin >> 4 );
    FP_OFF(p) = (unsigned int)( lin & 0xF );
    return p;
}
/*
** Adjust the GS register's limit to 4GB
**
** Note: interrupts are enabled by this call.
*/
void extend_seg( void )
{
    /*
    ** compute linear address and limit of GDT
    */
    gdtptr.linear_add = seg_to_linear(( void far * ) GDT );
    gdtptr.limit = 15;
    /*
    ** disable regular interrupts
    */
    disable();
    /*
    ** disable NMI
    */
    outp( RAMPORT, inp( RAMPORT ) | 0x80 );
}

```

```

/*
** call protected mode code
*/
protinit( &gdtptr );
/*
** Turn interrupts back on
*/
enable();
/*
** Turn NMI back on
*/
outp( RAMPOR, inp( RAMPOR ) & 0x7F );
}
void protinit( struct fword * address )
{
asm {
    .386P
    push ds
    lds bx,address
    lgdt FWORD ptr [bx]
    pop ds
    mov eax,cr0
    or al,0x01
    mov cr0,eax
    jmp short nxt
}
nxt:
asm {
    .386P
    mov bx,8
    mov gs,bx
    mov es,bx
    and al,0xfe
    mov cr0,eax
}
}
int fr_byte( FPTR adr )
{
int d;
asm {
    .386P
    xor ax,ax /* zero gs */
    mov gs,ax
    mov eax, adr
    mov al,byte ptr gs:[eax]
    mov d,ax
}
return d;
}
int fr_word( FPTR adr )
{
int d;
asm {
    .386P
    xor ax,ax /* zero gs */
    mov gs,ax
    mov eax, adr
    mov ax,word ptr gs:[eax]
    mov d,ax
}
return d;
}
long fr_long( FPTR adr )
{
long d;
asm {
    .386P
    xor ax,ax /* zero gs */
    mov gs,ax
    mov eax,adr
    mov eax,dword ptr gs:[eax]
    mov d,eax
}
return d;
}
void fw_byte( FPTR a, int d )

```

```

{
    asm {
        .386P
        xor    ax,ax        /* zero gs */
        mov    gs,ax
        mov    eax,a
        mov    bx,d
        mov    byte ptr gs:[eax],bl
    }
}
void fw_word( FPTR a, int d )
{
    asm {
        .386P
        xor    ax,ax        /* zero gs */
        mov    gs,ax
        mov    eax,a
        mov    bx,d
        mov    word ptr gs:[eax],bx
    }
}
void fw_long( FPTR a, long d )
{
    asm {
        .386P
        xor    ax,ax        /* zero gs */
        mov    gs,ax
        mov    eax,a
        mov    ebx,d
        mov    dword ptr gs:[eax],ebx
    }
}
/* flat move long */
void fml_string( FPTR d, FPTR s, long n )
{
    asm {
        .386P                /* have to use ES for string move */
        push es                /* save es */
        xor    ax,ax          /* zero gs */
        mov    gs,ax
        mov    es,ax
        mov    edi,d          /* This is the destination pointer */
        mov    esi,s          /* This is the source pointer */
        mov    ecx,n          /* This is the number of dwords */
        rep movs dword ptr es:[edi],dword ptr gs:[esi]
        pop es                /* give back es */
    }
}
/* flat move word */
void fmw_string( FPTR d, FPTR s, long n )
{
    asm {
        .386P                /* have to use ES for string move */
        push es                /* save es */
        xor    ax,ax          /* zero gs */
        mov    gs,ax
        mov    es,ax
        mov    edi,d          /* This is the destination pointer */
        mov    esi,s          /* This is the source pointer */
        mov    ecx,n          /* This is the number of words */
        rep movs word ptr es:[edi],word ptr gs:[esi]
        pop es                /* give back es */
    }
}
/* flat move byte */
void fmb_string( FPTR d, FPTR s, long n )

```

---

```
{
  asm {
    .386P          /* have to use ES for string move */
    push es       /* save es */
    xor  ax,ax    /* zero gs */
    mov  gs,ax
    mov  es,ax
    mov  edi,d    /* This is the destination pointer */
    mov  esi,s    /* This is the source pointer */
    mov  ecx,n    /* This is the number of bytes */
    rep movs byte ptr es:[edi],byte ptr gs:[esi]
    pop  es       /* give back es */
  }
}
```

## \*\* FILE: FLAT.H

```

/*
** flat.h
**
** Prototypes typedefs and macros for flat memory access
**
*/
typedef unsigned long FPTR;
/*
** Global descriptor table
*/
struct _GDT {
    unsigned int limit;
    unsigned int base;
    unsigned int access;
    unsigned int hi_limit;
};
static struct _GDT GDT[2]= {
    {0,0,0,0}, /* Null selector slot */
    {0xFFFF,0,0x9200,0x8F} /* 4 Gig data segment */
};
/*
** FWORD pointer to GDT
*/
struct fword {
    unsigned int limit;
    unsigned long linear_add;
};
/*
** convert segmented address to linear address
*/
#define seg_to_linear(fp) (((FPTR) FP_SEG(fp)<<4)+FP_OFF(fp))
/*
** flat memory function prototypes
*/
void a20( int );
void far * linear_to_seg( FPTR );
void extend_seg( void );
void protinit( struct fword * );
int fr_byte( FPTR ); /* flat read byte */
void fw_byte( FPTR, int ); /* flat write byte */
int fr_word( FPTR ); /* flat read word */
void fw_word( FPTR, int ); /* flat write word */
long fr_long( FPTR ); /* flat read long */
void fw_long( FPTR, long ); /* flat write long */
void fml_string( FPTR, FPTR, long ); /* flat move long */
void fmw_string( FPTR, FPTR, long ); /* flat move word */
void fmb_string( FPTR, FPTR, long ); /* flat move byte */

```

## \*\* FILE: PCI.C

```

#include <dos.h>
#include <stddef.h>
#include "pci.h"
#define HIGH_BYTE(ax) (ax >> 8)
#define LOW_BYTE(ax) (ax & 0xff)
int find_pci_device(unsigned short device_id,
                   unsigned short vendor_id,
                   unsigned short index,
                   unsigned char *bus_number,
                   unsigned char *device_and_function)
{
    int ret_status;
    unsigned short ax, bx, flags;
    _CX = device_id;
    _DX = vendor_id;
    _SI = index;
    _AH = PCI_FUNCTION_ID;
    _AL = FIND_PCI_DEVICE;
    geninterrupt(0x1a);
    ax = _AX;
    bx = _BX;
    flags = _FLAGS;
    if ((flags & CARRY_FLAG) == 0)
    {
        ret_status = HIGH_BYTE(ax);
        if (ret_status == SUCCESSFUL)
        {
            if (bus_number != NULL) *bus_number = HIGH_BYTE(bx);
            if (device_and_function != NULL) *device_and_function = LOW_BYTE(bx);
        }
    }
    else
    {
        ret_status = NOT_SUCCESSFUL;
    }
    return(ret_status);
}

int read_configuration_area(unsigned char function,
                           unsigned char bus_number,
                           unsigned char device_and_function,
                           unsigned char register_number,
                           unsigned long *data)
{
    int ret_status;
    unsigned short ax, flags;
    unsigned long ecx;
    _BH = bus_number;
    _BL = device_and_function;
    _DI = register_number;
    _AH = PCI_FUNCTION_ID;
    _AL = function;
    geninterrupt(0x1a);
    ecx = _ECX;
    ax = _AX;
    flags = _FLAGS;
    if ((flags & CARRY_FLAG) == 0)
    {
        ret_status = HIGH_BYTE(ax);
        if (ret_status == SUCCESSFUL)
        {
            *data = ecx;
        }
    }
    else
    {
        ret_status = NOT_SUCCESSFUL;
    }
    return(ret_status);
}

```

```
}
int write_configuration_area(unsigned char function,
                            unsigned char bus_number,
                            unsigned char device_and_function,
                            unsigned char register_number,
                            unsigned long value)
{
    int ret_status;
    unsigned short ax, flags;
    _BH = bus_number;
    _BL = device_and_function;
    _ECX = value;
    _DI = register_number;
    _AH = PCI_FUNCTION_ID;
    _AL = function;
    geninterrupt(0x1a);
    ax = _AX;
    flags = _FLAGS;
    if ((flags & CARRY_FLAG) == 0)
    {
        ret_status = HIGH_BYTE(ax);
    }
    else
    {
        ret_status = NOT_SUCCESSFUL;
    }
    return(ret_status);
}
void outpd(unsigned short port, unsigned long value)
{
    _DX = port;
    _EAX = value;
    __emit__(0x66, 0xEF);
}
unsigned long inpd(unsigned short port)
{
    _DX = port;
    __emit__(0x66, 0xED);
    return(_EAX);
}
```

**\*\* FILE: PCI.H**

```
#define TRUE 1
#define FALSE 0
#define CARRY_FLAG 0x01
/* PCI Functions */
#define PCI_FUNCTION_ID 0xB1
#define PCI_BIOS_PRESENT 0x01
#define FIND_PCI_DEVICE 0x02
#define FIND_PCI_CLASS_CODE 0x03
#define READ_CONFIG_BYTE 0x08
#define READ_CONFIG_WORD 0x09
#define READ_CONFIG_DWORD 0x0A
#define WRITE_CONFIG_BYTE 0x0B
#define WRITE_CONFIG_WORD 0x0C
#define WRITE_CONFIG_DWORD 0x0D
/* PCI Return codes */
#define SUCCESSFUL 0x00
#define NOT_SUCCESSFUL 0x01
/* Prototypes */
int find_pci_device(unsigned short device_id,
                   unsigned short vendor_id,
                   unsigned short index,
                   unsigned char *bus_number,
                   unsigned char *device_and_function);
int read_configuration_area(unsigned char function,
                           unsigned char bus_number,
                           unsigned char device_and_function,
                           unsigned char register_number,
                           unsigned long *data);
int write_configuration_area(unsigned char function,
                            unsigned char bus_number,
                            unsigned char device_and_function,
                            unsigned char register_number,
                            unsigned long value);
void outpd(unsigned short port, unsigned long value);
unsigned long inpd(unsigned short port);
```

## \*\* FILE: UNIVERSE.H

```

/*
** file: universe.h
**
**
** header file for the universe II chip register definitions
**
**
*/
typedef volatile struct universe_regs {
    unsigned long pci_id;          /* PCI device ID vendor ID */
    unsigned long pci_csr;        /* PCI config control/status reg */
    unsigned long pci_class;      /* PCI config class reg */
    unsigned long pci_misc0;      /* PCI config miscellaneous 0 reg */
    unsigned long pci_bs0;        /* PCI config base address reg */
    unsigned long pci_bsl;        /* PCI config base address reg */
    unsigned long pci_u0[0x04];   /* unimplemented */
    unsigned long pci_r0[0x02];   /* reserved */
    unsigned long pci_ul;        /* unimplemented */
    unsigned long pci_rl[0x02];   /* reserved */
    unsigned long pci_misc1;      /* PCI config miscellaneous 1 reg */
    unsigned long pci_u2[0x30];   /* unimplemented */
    unsigned long lsi0_ctl;       /* PCI slave image 0 control reg */
    unsigned long lsi0_bs;        /* PCI slave image 0 base address reg */
    unsigned long lsi0_bd;        /* PCI slave image 0 bound address reg */
    unsigned long lsi0_to;        /* PCI slave image 0 translation offset reg */
    unsigned long ur0;           /* reserved */
    unsigned long lsil_ctl;       /* PCI slave image 1 control reg */
    unsigned long lsil_bs;        /* PCI slave image 1 base address reg */
    unsigned long lsil_bd;        /* PCI slave image 1 bound address reg */
    unsigned long lsil_to;        /* PCI slave image 1 translation offset reg */
    unsigned long url;          /* reserved */
    unsigned long lsi2_ctl;       /* PCI slave image 2 control reg */
    unsigned long lsi2_bs;        /* PCI slave image 2 base address reg */
    unsigned long lsi2_bd;        /* PCI slave image 2 bound address reg */
    unsigned long lsi2_to;        /* PCI slave image 2 translation offset reg */
    unsigned long ur2;           /* reserved */
    unsigned long lsi3_ctl;       /* PCI slave image 3 control reg */
    unsigned long lsi3_bs;        /* PCI slave image 3 base address reg */
    unsigned long lsi3_bd;        /* PCI slave image 3 bound address reg */
    unsigned long lsi3_to;        /* PCI slave image 3 translation offset reg */
    unsigned long ur3[0x09];     /* reserved */
    unsigned long scyc_ctl;       /* PCI special cycle control reg */
    unsigned long scyc_addr;      /* PCI special cycle PCI address reg */
    unsigned long scyc_en;        /* PCI special cycle swap/compare enable reg */
    unsigned long scyc_cmp;       /* PCI special cycle compare data reg */
    unsigned long scyc_swp;       /* PCI special cycle swap data reg */
    unsigned long lmisc;         /* PCI miscellaneous reg */
    unsigned long sls1;          /* PCI special PCI slave image */
    unsigned long l_cmderr;       /* PCI command error log reg */
    unsigned long laerr;         /* PCI address error log reg */
    unsigned long ur4[0x03];     /* reserved */
    unsigned long lsi4_ctl;       /* PCI slave image 4 control reg */
    unsigned long lsi4_bs;        /* PCI slave image 4 base address reg */
    unsigned long lsi4_bd;        /* PCI slave image 4 bound address reg */
    unsigned long lsi4_to;        /* PCI slave image 4 translation offset reg */
    unsigned long ur5;           /* reserved */
    unsigned long lsi5_ctl;       /* PCI slave image 5 control reg */
    unsigned long lsi5_bs;        /* PCI slave image 5 base address reg */
    unsigned long lsi5_bd;        /* PCI slave image 5 bound address reg */
    unsigned long lsi5_to;        /* PCI slave image 5 translation offset reg */
    unsigned long ur6;           /* reserved */
    unsigned long lsi6_ctl;       /* PCI slave image 6 control reg */
    unsigned long lsi6_bs;        /* PCI slave image 6 base address reg */
    unsigned long lsi6_bd;        /* PCI slave image 6 bound address reg */
    unsigned long lsi6_to;        /* PCI slave image 6 translation offset reg */
    unsigned long ur7;           /* reserved */
    unsigned long lsi7_ctl;       /* PCI slave image 7 control reg */
    unsigned long lsi7_bs;        /* PCI slave image 7 base address reg */
    unsigned long lsi7_bd;        /* PCI slave image 7 bound address reg */
    unsigned long lsi7_to;        /* PCI slave image 7 translation offset reg */
    unsigned long ur8[0x05];     /* reserved */
    unsigned long dct1;          /* DMA transfer control reg */
    unsigned long dtbc;          /* DMA transfer byte count reg */
}

```

```
unsigned long dla; /* DMA PCIbus address reg */
unsigned long ur9; /* reserved */
unsigned long dva; /* DMA VMEbus address reg */
unsigned long urA; /* reserved */
unsigned long dcpp; /* DMA command packet pointer */
unsigned long urB; /* reserved */
unsigned long dgcs; /* DMA general control and status reg */
unsigned long d_llue; /* DMA linked list update enable reg */
unsigned long urC[0x36]; /* reserved */
unsigned long lint_en; /* PCI interrupt enable */
unsigned long lint_stat; /* PCI interrupt status */
unsigned long lint_map0; /* PCI interrupt map0 */
unsigned long lint_map1; /* PCI interrupt map1 */
unsigned long vint_en; /* VME interrupt enable */
unsigned long vint_stat; /* VME interrupt status */
unsigned long vint_map0; /* VME interrupt map0 */
unsigned long vint_map1; /* VME interrupt map1 */
unsigned long statid; /* VME interrupt status/ID out */
unsigned long v1_statid; /* VME interrupt status/ID in IRQ1 */
unsigned long v2_statid; /* VME interrupt status/ID in IRQ2 */
unsigned long v3_statid; /* VME interrupt status/ID in IRQ3 */
unsigned long v4_statid; /* VME interrupt status/ID in IRQ4 */
unsigned long v5_statid; /* VME interrupt status/ID in IRQ5 */
unsigned long v6_statid; /* VME interrupt status/ID in IRQ6 */
unsigned long v7_statid; /* VME interrupt status/ID in IRQ7 */
unsigned long lint_map2; /* PCI interrupt map2 */
unsigned long vint_map2; /* VME interrupt map2 */
unsigned long mbox0; /* Mailbox 0 */
unsigned long mbox1; /* Mailbox 1 */
unsigned long mbox2; /* Mailbox 2 */
unsigned long mbox3; /* Mailbox 3 */
unsigned long sema0; /* Semaphore 0 */
unsigned long sema1; /* Semaphore 1 */
unsigned long urD[0x28]; /* reserved */
unsigned long mast_ctl; /* master control reg */
unsigned long misc_ctl; /* miscellaneous control reg */
unsigned long misc_stat; /* miscellaneous status reg */
unsigned long user_am; /* user AM codes reg */
unsigned long urE[0x2bc]; /* reserved */
unsigned long vsi0_ctl; /* VMEbus slave image 0 control reg */
unsigned long vsi0_bs; /* VMEbus slave image 0 base address reg */
unsigned long vsi0_bd; /* VMEbus slave image 0 bound address reg */
unsigned long vsi0_to; /* VMEbus slave image 0 translation offset */
unsigned long urF; /* reserved */
unsigned long vsi1_ctl; /* VMEbus slave image 1 control reg */
unsigned long vsi1_bs; /* VMEbus slave image 1 base address reg */
unsigned long vsi1_bd; /* VMEbus slave image 1 bound address reg */
unsigned long vsi1_to; /* VMEbus slave image 1 translation offset */
unsigned long urG; /* reserved */
unsigned long vsi2_ctl; /* VMEbus slave image 2 control reg */
unsigned long vsi2_bs; /* VMEbus slave image 2 base address reg */
unsigned long vsi2_bd; /* VMEbus slave image 2 bound address reg */
unsigned long vsi2_to; /* VMEbus slave image 2 translation offset */
unsigned long urH; /* reserved */
unsigned long vsi3_ctl; /* VMEbus slave image 3 control reg */
unsigned long vsi3_bs; /* VMEbus slave image 3 base address reg */
unsigned long vsi3_bd; /* VMEbus slave image 3 bound address reg */
unsigned long vsi3_to; /* VMEbus slave image 3 translation offset */
unsigned long urI[0x06]; /* reserved */
unsigned long lm_ctl; /* Location Monitor Control */
unsigned long lm_bs; /* Location Monitor Base Address */
unsigned long urJ; /* reserved */
unsigned long vra_i_ctl; /* VMEbus register access image control reg */
unsigned long vra_i_bs; /* VMEbus register access image base address */
unsigned long urK[0x02]; /* reserved */
unsigned long vcsr_ctl; /* VMEbus CSR control reg */
unsigned long vcsr_to; /* VMEbus CSR translation reg */
unsigned long v_amerr; /* VMEbus AM code error log */
unsigned long vaerr; /* VMEbus address error log */
unsigned long vsi4_ctl; /* VMEbus slave image 4 control reg */
unsigned long vsi4_bs; /* VMEbus slave image 4 base address reg */
unsigned long vsi4_bd; /* VMEbus slave image 4 bound address reg */
unsigned long vsi4_to; /* VMEbus slave image 4 translation offset */
unsigned long urL; /* reserved */
unsigned long vsi5_ctl; /* VMEbus slave image 5 control reg */
unsigned long vsi5_bs; /* VMEbus slave image 5 base address reg */
unsigned long vsi5_bd; /* VMEbus slave image 5 bound address reg */
unsigned long vsi5_to; /* VMEbus slave image 5 translation offset */
unsigned long urM; /* reserved */
```

```

unsigned long vsi6_ctl;      /* VMEbus slave image 6 control reg */
unsigned long vsi6_bs;      /* VMEbus slave image 6 base address reg */
unsigned long vsi6_bd;      /* VMEbus slave image 6 bound address reg */
unsigned long vsi6_to;      /* VMEbus slave image 6 translation offset */
unsigned long urN;          /* reserved */
unsigned long vsi7_ctl;     /* VMEbus slave image 7 control reg */
unsigned long vsi7_bs;     /* VMEbus slave image 7 base address reg */
unsigned long vsi7_bd;     /* VMEbus slave image 7 bound address reg */
unsigned long vsi7_to;     /* VMEbus slave image 7 translation offset */
unsigned long urP[0x05];   /* reserved */
unsigned long v_cr_csr;     /* VMEbus CR/CSR reserved */
unsigned long vcsr_clr;    /* VMEbus CSR bit clear reg */
unsigned long vcsr_set;    /* VMEbus CSR bit set reg */
unsigned long vcsr_bs;     /* VMEbus CSR base address reg */
} universe_regs_t;
#define PCI_ID_A 0x000 /* PCI device ID vendor ID */
#define PCI_CSR_A 0x004 /* PCI config control/status reg */
#define PCI_CLASS_A 0x008 /* PCI config class reg */
#define PCI_MISCO_A 0x00C /* PCI config miscellaneous 0 reg */
#define PCI_BS0_A 0x010 /* PCI config base address reg */
#define PCI_BS1_A 0x014 /* PCI config base address reg */
#define PCI_MISCL_A 0x03C /* PCI config miscellaneous 1 reg */
#define LSI0_CTL_A 0x100 /* PCI slave image 0 control reg */
#define LSI0_BS_A 0x104 /* PCI slave image 0 base address reg */
#define LSI0_BD_A 0x108 /* PCI slave image 0 bound address reg */
#define LSI0_TO_A 0x10C /* PCI slave image 0 translation offset reg */
#define LSI1_CTL_A 0x114 /* PCI slave image 1 control reg */
#define LSI1_BS_A 0x118 /* PCI slave image 1 base address reg */
#define LSI1_BD_A 0x11C /* PCI slave image 1 bound address reg */
#define LSI1_TO_A 0x120 /* PCI slave image 1 translation offset reg */
#define LSI2_CTL_A 0x128 /* PCI slave image 2 control reg */
#define LSI2_BS_A 0x12C /* PCI slave image 2 base address reg */
#define LSI2_BD_A 0x130 /* PCI slave image 2 bound address reg */
#define LSI2_TO_A 0x134 /* PCI slave image 2 translation offset reg */
#define LSI3_CTL_A 0x13C /* PCI slave image 3 control reg */
#define LSI3_BS_A 0x140 /* PCI slave image 3 base address reg */
#define LSI3_BD_A 0x144 /* PCI slave image 3 bound address reg */
#define LSI3_TO_A 0x148 /* PCI slave image 3 translation offset reg */
#define SCYC_CTL_A 0x170 /* PCI special cycle control reg */
#define SCYC_ADDR_A 0x174 /* PCI special cycle PCI address reg */
#define SCYC_EN_A 0x178 /* PCI special cycle swap/compare enable reg */
#define SCYC_CMP_A 0x17C /* PCI special cycle compare data reg */
#define SCYC_SWP_A 0x180 /* PCI special cycle swap data reg */
#define LMISC_A 0x184 /* PCI miscellaneous reg */
#define SLSI_A 0x188 /* PCI special PCI slave image */
#define L_CMDERR_A 0x18C /* PCI command error log reg */
#define LAERR_A 0x190 /* PCI address error log reg */
#define LSI4_CTL_A 0x1A0 /* PCI slave image 4 control reg */
#define LSI4_BS_A 0x1A4 /* PCI slave image 4 base address reg */
#define LSI4_bd_A 0x1A8 /* PCI slave image 4 bound address reg */
#define LSI4_TO_A 0x1AC /* PCI slave image 4 translation offset reg */
#define LSI5_CTL_A 0x1B4 /* PCI slave image 5 control reg */
#define LSI5_BS_A 0x1B8 /* PCI slave image 5 base address reg */
#define LSI5_BD_A 0x1BC /* PCI slave image 5 bound address reg */
#define LSI5_TO_A 0x1C0 /* PCI slave image 5 translation offset reg */
#define LSI6_CTL_A 0x1C8 /* PCI slave image 6 control reg */
#define LSI6_BS_A 0x1CC /* PCI slave image 6 base address reg */
#define LSI6_BD_A 0x1D0 /* PCI slave image 6 bound address reg */
#define LSI6_TO_A 0x1D4 /* PCI slave image 6 translation offset reg */
#define LSI7_CTL_A 0x1DC /* PCI slave image 7 control reg */
#define LSI7_BS_A 0x1E0 /* PCI slave image 7 base address reg */
#define LSI7_BD_A 0x1E4 /* PCI slave image 7 bound address reg */
#define LSI7_TO_A 0x1E8 /* PCI slave image 7 translation offset reg */
#define DCTL_A 0x200 /* DMA transfer control reg */
#define DTBC_A 0x204 /* DMA transfer byte count reg */
#define DLA_A 0x208 /* DMA PCIbus address reg */
#define DVA_A 0x210 /* DMA VMEbus address reg */
#define DCPA_A 0x218 /* DMA command packet pointer */
#define DGCS_A 0x220 /* DMA general control and status reg */
#define D_LLUE_A 0x224 /* DMA linked list update enable reg */
#define LINT_EN_A 0x300 /* PCI interrupt enable */
#define LINT_STAT_A 0x304 /* PCI interrupt status */
#define LINT_MAP0_A 0x308 /* PCI interrupt map0 */
#define LINT_MAP1_A 0x30C /* PCI interrupt map1 */
#define VINT_EN_A 0x310 /* VME interrupt enable */
#define VINT_STAT_A 0x314 /* VME interrupt status */
#define VINT_MAP0_A 0x318 /* VME interrupt map0 */
#define VINT_MAP1_A 0x31C /* VME interrupt map1 */
#define STATID_A 0x320 /* VME interrupt status/ID out */

```

```

#define V1_STATID_A 0x324 /* VME interrupt status/ID in IRQ1 */
#define V2_STATID_A 0x328 /* VME interrupt status/ID in IRQ2 */
#define V3_STATID_A 0x32C /* VME interrupt status/ID in IRQ3 */
#define V4_STATID_A 0x330 /* VME interrupt status/ID in IRQ4 */
#define V5_STATID_A 0x334 /* VME interrupt status/ID in IRQ5 */
#define V6_STATID_A 0x338 /* VME interrupt status/ID in IRQ6 */
#define V7_STATID_A 0x33C /* VME interrupt status/ID in IRQ7 */
#define LINT_MAP2_A 0x340 /* PCI interrupt map2 */
#define VINT_MAP2_A 0x344 /* VME interrupt map2 */
#define MBOX0_A 0x348 /* Mailbox 0 */
#define MBOX1_A 0x34C /* Mailbox 1 */
#define MBOX2_A 0x350 /* Mailbox 2 */
#define MBOX3_A 0x354 /* Mailbox 3 */
#define SEMA0_A 0x358 /* Semaphore 0 */
#define SEMA1_A 0x35C /* Semaphore 1 */
#define MAST_CTL_A 0x400 /* master control reg */
#define MISC_CTL_A 0x404 /* miscellaneous control reg */
#define MISC_STAT_A 0x408 /* miscellaneous status reg */
#define USER_AM_A 0x40C /* user AM codes reg */
#define VSI0_CTL_A 0xF00 /* VMEbus slave image 0 control reg */
#define VSI0_BS_A 0xF04 /* VMEbus slave image 0 base address reg */
#define VSI0_BD_A 0xF08 /* VMEbus slave image 0 bound address reg */
#define VSI0_TO_A 0xF0C /* VMEbus slave image 0 translation offset */
#define VSI1_CTL_A 0xF14 /* VMEbus slave image 1 control reg */
#define VSI1_BS_A 0xF18 /* VMEbus slave image 1 base address reg */
#define VSI1_BD_A 0xF1C /* VMEbus slave image 1 bound address reg */
#define VSI1_TO_A 0xF20 /* VMEbus slave image 1 translation offset */
#define VSI2_CTL_A 0xF28 /* VMEbus slave image 2 control reg */
#define VSI2_BS_A 0xF2C /* VMEbus slave image 2 base address reg */
#define VSI2_BD_A 0xF30 /* VMEbus slave image 2 bound address reg */
#define VSI2_TO_A 0xF34 /* VMEbus slave image 2 translation offset */
#define VSI3_CTL_A 0xF3C /* VMEbus slave image 3 control reg */
#define VSI3_BS_A 0xF40 /* VMEbus slave image 3 base address reg */
#define VSI3_BD_A 0xF44 /* VMEbus slave image 3 bound address reg */
#define VSI3_TO_A 0xF48 /* VMEbus slave image 3 translation offset */
#define LM_CTL_A 0xF64 /* Location Monitor Control */
#define LM_BS_A 0xF68 /* Location Monitor Base Address */
#define VRAI_CTL_A 0xF70 /* VMEbus register access image control reg */
#define VRAI_BS_A 0xF74 /* VMEbus register access image base address */
#define VCSR_CTL_A 0xF80 /* VMEbus CSR control reg */
#define VCSR_TO_A 0xF84 /* VMEbus CSR translation reg */
#define V_AMERR_A 0xF88 /* VMEbus AM code error log */
#define VAERR_A 0xF8C /* VMEbus address error log */
#define VSI4_CTL_A 0xF90 /* VMEbus slave image 4 control reg */
#define VSI4_BS_A 0xF94 /* VMEbus slave image 4 base address reg */
#define VSI4_BD_A 0xF98 /* VMEbus slave image 4 bound address reg */
#define VSI4_TO_A 0xF9C /* VMEbus slave image 4 translation offset */
#define VSI5_CTL_A 0xFA4 /* VMEbus slave image 5 control reg */
#define VSI5_BS_A 0xFA8 /* VMEbus slave image 5 base address reg */
#define VSI5_BD_A 0xFAC /* VMEbus slave image 5 bound address reg */
#define VSI5_TO_A 0xFB0 /* VMEbus slave image 5 translation offset */
#define VSI6_CTL_A 0xFB8 /* VMEbus slave image 6 control reg */
#define VSI6_BS_A 0xFB4 /* VMEbus slave image 6 base address reg */
#define VSI6_BD_A 0xFC0 /* VMEbus slave image 6 bound address reg */
#define VSI6_TO_A 0xFC4 /* VMEbus slave image 6 translation offset */
#define VSI7_CTL_A 0xFCC /* VMEbus slave image 7 control reg */
#define VSI7_BS_A 0xFD0 /* VMEbus slave image 7 base address reg */
#define VSI7_BD_A 0xFD4 /* VMEbus slave image 7 bound address reg */
#define VSI7_TO_A 0xFD8 /* VMEbus slave image 7 translation offset */
#define V_CR_CSR_A 0xFF0 /* VMEbus CR/CSR reserved */
#define VCSR_CLR_A 0xFF4 /* VMEbus CSR bit clear reg */
#define VCSR_SET_A 0xFF8 /* VMEbus CSR bit set reg */
#define VCSR_BS_A 0xFFC /* VMEbus CSR base address reg */
/* PCI and VME slave window structure */
typedef struct slave_window {
    unsigned long win_ctl;
    unsigned long win_bs;
    unsigned long win_bd;
    unsigned long win_to;
} swin_config_t;

```

```

/* DMA command packet structure for dmas using linked lists */
typedef struct dma_command_pkt {
    unsigned long dma_dctl; /* DMA transfer control reg */
    unsigned long dma_dtbc; /* DMA transfer byte count reg */
    unsigned long dma_dla; /* DMA PCI bus address reg */
    unsigned long rsvd1; /* RESERVED */
    unsigned long dma_dva; /* DMA VMEbus address reg */
    unsigned long rsvd2; /* RESERVED */
    unsigned long dma_dcpp; /* DMA command packet pointer reg */
    unsigned long rsvd3; /* RESERVED */
} dma_cmd_pkt_t;

/* pci_id - PCI device ID and vendor ID */
#define PCI_DID_VID 0x000010E3 /* R PCI device ID vendor ID */
/* pci_csr - PCI configuration space control and status register */
#define PCI_CSR_D_PE 0x80000000 /* R/WC detected parity error */
#define PCI_CSR_S_SERR 0x40000000 /* R/WC signalled SERR* */
#define PCI_CSR_R_MA 0x20000000 /* R/WC received master abort */
#define PCI_CSR_R_TA 0x10000000 /* R/WC received target abort */
#define PCI_CSR_S_TA 0x08000000 /* R/WC signalled target abort */
#define PCI_CSR_DEVSEL 0x02000000 /* R device select timing - medium */
#define PCI_CSR_DP_D 0x01000000 /* RC data parity detected */
#define PCI_CSR_TFBBC 0x00800000 /* R target fast back-to-back capable */
#define PCI_CSR_MFBBC 0x00000000 /* R master fast back-to-back capable */
#define PCI_CSR_SERR_EN 0x00000100 /* R/W SERR* enable */
#define PCI_CSR_WAIT 0x00000080 /* R wait cycle control */
#define PCI_CSR_PERESP 0x00000040 /* R/W parity error response */
#define PCI_CSR_VGAPS 0x00000020 /* R VGA palette snoop */
#define PCI_CSR_MWI_EN 0x00000010 /* R mem write and invalidate enable */
#define PCI_CSR_SC 0x00000008 /* R special cycles */
#define PCI_CSR_BM 0x00000004 /* R/W master enable */
#define PCI_CSR_MS 0x00000002 /* R/W target memory enable */
#define PCI_CSR_IOS 0x00000001 /* R/W target I/O enable */
/* pci_class - PCI configuration class register */
#define PCI_CLASS_BASE 0x06000000 /* R base class code */
#define PCI_CLASS_SUB 0x00800000 /* R sub class code */
#define PCI_CLASS_PROG 0x00000000 /* R programming interface */
#define PCI_CLASS_RID 0x00000000 /* R revision ID */
/* pci_misc0 - PCI configuration miscellaneous 0 register */
#define PCI_MISC0_BISTC 0x80000000 /* R BIST capable N/A */
#define PCI_MISC0_SBIST 0x40000000 /* R start BIST N/A */
#define PCI_MISC0_CCODE 0x0F000000 /* R completion code MASK */
#define PCI_MISC0_MFUNCT 0x00800000 /* R multifunction device */
#define PCI_MISC0_LAYOUT 0x007F0000 /* R configuration space layout MASK */
#define PCI_MISC0_LTIMER 0x0000F800 /* R/W latency timer MASK */
/* pci_bs - PCI configuration base address register */
#define PCI_BS_BS 0xFFFF0000 /* R PCI base address MASK */
#define PCI_BS_SPACE_M 0x00000000 /* R PCI address space memory */
#define PCI_BS_SPACE_IO 0x00000001 /* R PCI address space I/O */
/* pci_miscl - PCI configuration miscellaneous 1 register */
#define PCI_MISCL_MAX_LAT 0x00000000 /* R maximum latency: none */
#define PCI_MISCL_MAX_GNT 0x00030000 /* R minimum grant: 250 ns */
#define PCI_MISCL_INT_PIN 0x00000100 /* R interrupt pin */
#define PCI_MISCL_INT_LINE 0x000000FF /* R/W interrupt line MASK */
/* LSI[X]_ctl - slave image control registers ( lsi0 - lsi7 ) */
#define LSI_CTL_EN 0x80000000 /* R/W image enable */
#define LSI_CTL_PWEN 0x40000000 /* R/W posted write enable */
#define LSI_CTL_VDW_08 0x00000000 /* R/W VMEbus maximum data width D08 */
#define LSI_CTL_VDW_16 0x00400000 /* R/W VMEbus maximum data width D16 */
#define LSI_CTL_VDW_32 0x00800000 /* R/W VMEbus maximum data width D32 */
#define LSI_CTL_VDW_64 0x00C00000 /* R/W VMEbus maximum data width D64 */
#define LSI_CTL_VAS_16 0x00000000 /* R/W VMEbus address space A16 */
#define LSI_CTL_VAS_24 0x00010000 /* R/W VMEbus address space A24 */
#define LSI_CTL_VAS_32 0x00020000 /* R/W VMEbus address space A32 */
#define LSI_CTL_VAS_R1 0x00030000 /* R/W VMEbus address space RSVd1 */
#define LSI_CTL_VAS_R2 0x00040000 /* R/W VMEbus address space RSVd2 */
#define LSI_CTL_VAS_CR 0x00050000 /* R/W VMEbus address space CR/CSR */
#define LSI_CTL_VAS_U1 0x00060000 /* R/W VMEbus address space USER1 */
#define LSI_CTL_VAS_U2 0x00070000 /* R/W VMEbus address space USER2 */
#define LSI_CTL_PGM_D 0x00000000 /* R/W VMEbus data AM code */
#define LSI_CTL_PGM_P 0x00004000 /* R/W VMEbus program AM code */
#define LSI_CTL_SUPER 0x00001000 /* R/W VMEbus supervisory AM code */
#define LSI_CTL_VCT_S 0x00000000 /* R/W VMEbus single cycles only */
#define LSI_CTL_VCT_SB 0x00000100 /* R/W VMEbus single cycles and block */
#define LSI_CTL_LAS_M 0x00000000 /* R/W PCIbus memory space */
#define LSI_CTL_LAS_IO 0x00000001 /* R/W PCIbus I/O space */
#define LSI_CTL_LAS_C 0x00000002 /* R/W PCIbus type 1 config space */
#define LSI_CTL_LAS_R 0x00000003 /* R/W PCIbus reserved */
/* lsi[X]_bs - slave image 0/1/2/3/4/5/6/7 base address register 0x0000?XXX */
#define LSI0_BS 0xFFFFF000 /* R/W PCI slave image 0 base address MASK */

```

```
#define LSI1_BS 0xFFFF0000 /* R/W PCI slave image 1 base address MASK */
#define LSI2_BS 0xFFFF0000 /* R/W PCI slave image 2 base address MASK */
#define LSI3_BS 0xFFFF0000 /* R/W PCI slave image 3 base address MASK */
#define LSI4_BS 0xFFFF0000 /* R/W PCI slave image 4 base address MASK */
#define LSI5_BS 0xFFFF0000 /* R/W PCI slave image 5 base address MASK */
#define LSI6_BS 0xFFFF0000 /* R/W PCI slave image 6 base address MASK */
#define LSI7_BS 0xFFFF0000 /* R/W PCI slave image 7 base address MASK */
/* lsi[X]_bd - slave image 0/1/2/3/4/5/6/7 bound address register 0x0000?XXX */
#define LSI0_BD 0xFFFF0000 /* R/W PCI slave image 0 bound addr MASK */
#define LSI1_BD 0xFFFF0000 /* R/W PCI slave image 1 bound addr MASK */
#define LSI2_BD 0xFFFF0000 /* R/W PCI slave image 2 bound addr MASK */
#define LSI3_BD 0xFFFF0000 /* R/W PCI slave image 3 bound addr MASK */
#define LSI4_BD 0xFFFF0000 /* R/W PCI slave image 4 bound addr MASK */
#define LSI5_BD 0xFFFF0000 /* R/W PCI slave image 5 bound addr MASK */
#define LSI6_BD 0xFFFF0000 /* R/W PCI slave image 6 bound addr MASK */
#define LSI7_BD 0xFFFF0000 /* R/W PCI slave image 7 bound addr MASK */
/* lsi[X]_to - slave image 0/1/2/3/4/5/6/7 translation offset reg 0x0000?XXX */
#define LSI0_TO 0xFFFF0000 /* R/W PCI slave image 0 xfer offset MASK */
#define LSI1_TO 0xFFFF0000 /* R/W PCI slave image 1 xfer offset MASK */
#define LSI2_TO 0xFFFF0000 /* R/W PCI slave image 2 xfer offset MASK */
#define LSI3_TO 0xFFFF0000 /* R/W PCI slave image 3 xfer offset MASK */
#define LSI4_TO 0xFFFF0000 /* R/W PCI slave image 4 xfer offset MASK */
#define LSI5_TO 0xFFFF0000 /* R/W PCI slave image 5 xfer offset MASK */
#define LSI6_TO 0xFFFF0000 /* R/W PCI slave image 6 xfer offset MASK */
#define LSI7_TO 0xFFFF0000 /* R/W PCI slave image 7 xfer offset MASK */
/* scyc_ctl - special cycle control register */
#define SCYC_CTL_MEM 0x00000000 /* R/W PCI bus Memory space */
#define SCYC_CTL_IO 0x00000004 /* R/W PCI bus I/O space */
#define SCYC_CTL_DIS 0x00000000 /* R/W special cycle disabled */
#define SCYC_CTL_RMW 0x00000001 /* R/W read-modify-write */
#define SCYC_CTL_ADOH 0x00000002 /* R/W address only */
#define SCYC_CTL_RSVD 0x00000003 /* R/W reserved */
/* scyc_addr - special cycle PCI bus address register 0x0000000X */
#define SCYC_ADDR 0xFFFFFFF0 /* R/W special cycle PCIbus add reg MASK */
/* scyc_en - special cycle swap/compare enable register 0x00000000 */
#define SCYC_EN 0xFFFFFFFF /* R/W special cycle swap/compare en MASK */
/* scyc_cmp - special cycle compare data register 0x00000000 */
#define SCYC_CMP 0xFFFFFFFF /* R/W special cycle compare data MASK */
/* scyc_swp - special cycle swap data register 0x00000000 */
#define SCYC_SWP 0xFFFFFFFF /* R/W special cycle swap data MASK */
/* lmisc - PCI miscellaneous register */
#define LMISC_CRT_D 0x00000000 /* R/W coupled request timer disabled */
#define LMISC_CRT_1 0x10000000 /* R/W coupled request timer 128 us */
#define LMISC_CRT_2 0x20000000 /* R/W coupled request timer 256 us */
#define LMISC_CRT_3 0x30000000 /* R/W coupled request timer 512 us */
#define LMISC_CRT_4 0x40000000 /* R/W coupled request timer 1024 us */
#define LMISC_CRT_5 0x50000000 /* R/W coupled request timer 2048 us */
#define LMISC_CRT_6 0x60000000 /* R/W coupled request timer 4096 us */
#define LMISC_CWT_D 0x00000000 /* R/W coupled window timer disabled */
#define LMISC_CWT_1 0x01000000 /* R/W coupled window timer 128 us */
#define LMISC_CWT_2 0x02000000 /* R/W coupled window timer 256 us */
#define LMISC_CWT_3 0x03000000 /* R/W coupled window timer 512 us */
#define LMISC_CWT_4 0x04000000 /* R/W coupled window timer 1024 us */
#define LMISC_CWT_5 0x05000000 /* R/W coupled window timer 2048 us */
#define LMISC_CWT_6 0x06000000 /* R/W coupled window timer 4096 us */
/* slsi - special PCI slave image */
#define SLSI_EN 0x80000000 /* R/W image enable */
#define SLSI_PWEN 0x40000000 /* R/W posted write enable */
#define SLSI_VDW 0x00F00000 /* R/W VME max data width MASK */
#define SLSI_PGM 0x0000F000 /* R/W VME program/data AM code MASK */
#define SLSI_SUPER 0x00000F00 /* R/W VME supervisor/user AM code MASK */
#define SLSI_BS 0x000000FC /* R/W base address MASK */
#define SLSI_LAS_M 0x00000000 /* R/W PCIbus memory space */
#define SLSI_LAS_IO 0x00000001 /* R/W PCIbus I/O space */
#define SLSI_LAS_C 0x00000002 /* R/W PCIbus type 1 configuration space */
#define SLSI_LAS_R 0x00000003 /* R/W PCIbus reserved */
/* lcmderr - PCI command error log register */
#define L_CMDERR_CMDERR 0xF0000000 /* R PCI command error log MASK */
#define L_CMDERR_M_ERR 0x08000000 /* R multiple error occurred */
#define L_CMDERR_L_STAT 0x00800000 /* R/WC PCI error log status */
/* laerr - R PCI address error log 0x00000000 */
#define LAERR 0xFFFFFFFF /* PCI address error log MASK */
/* dctl - DMA transfer control register */
#define DCTL_L2V_I 0x00000000 /* R/W direction: VME -> PCI */
#define DCTL_L2V_O 0x80000000 /* R/W direction: PCI -> VME */
#define DCTL_VDW_08 0x00000000 /* R/W VMEbus max data width D08 */
#define DCTL_VDW_16 0x00400000 /* R/W VMEbus max data width D16 */
#define DCTL_VDW_32 0x00800000 /* R/W VMEbus max data width D32 */
#define DCTL_VDW_64 0x00C00000 /* R/W VMEbus max data width D64 */
```

```

#define DCTL_VAS_16 0x00000000 /* R/W VMEbus address space A16 */
#define DCTL_VAS_24 0x00010000 /* R/W VMEbus address space A24 */
#define DCTL_VAS_32 0x00020000 /* R/W VMEbus address space A32 */
#define DCTL_VAS_R1 0x00030000 /* R/W VMEbus address space reserved 1 */
#define DCTL_VAS_R2 0x00040000 /* R/W VMEbus address space reserved 2 */
#define DCTL_VAS_R3 0x00050000 /* R/W VMEbus address space reserved 3 */
#define DCTL_VAS_U1 0x00060000 /* R/W VMEbus address space user 1 */
#define DCTL_VAS_U2 0x00070000 /* R/W VMEbus address space user 2 */
#define DCTL_PGM_D 0x00000000 /* R/W VMEbus data AM code */
#define DCTL_PGM_P 0x00004000 /* R/W VMEbus program AM code */
#define DCTL_SUPER 0x00001000 /* R/W VMEbus supervisory AM code */
#define DCTL_VCT_S 0x00000000 /* R/W VMEbus single cycles only */
#define DCTL_VCT_SB 0x00000100 /* R/W VMEbus single cycles and block */
#define DCTL_LD64EN 0x00000080 /* R/W enable 64 bit PCI transaction */
/* dtbc - DMA transfer byte count register 0xXX000000 */
#define DTBC 0x00FFFFFF /* R/W DMA xfer byte count MASK */
/* dla - DMA PCIbus address register 0x0000000X */
#define DLA 0xFFFFFFFF /* R/W DMA PCIbus address MASK */
/* dva - DMA VMEbus address register 0x0000000X */
#define DVA 0xFFFFFFFF /* R/W DMA VMEbus address MASK */
/* dcpp - DMA command packet pointer 0x0000000X */
#define DCPP 0xFFFFFFFF8 /* R/W DMA command packet pointer MASK */
/* dgcs - DMA general control/status register */
#define DGCS_GO 0x80000000 /* R/W DMA go bit */
#define DGCS_STOP_REQ 0x40000000 /* R/W DMA stop request */
#define DGCS_HALT_REQ 0x20000000 /* R/W DMA halt request */
#define DGCS_CHAIN 0x08000000 /* R/W DMA chaining */
#define DGCS_VON1 0x00000000 /* R/W VME aligned DMA xfer cnt DONE */
#define DGCS_VON2 0x00100000 /* R/W VME aligned DMA xfer cnt 256 */
#define DGCS_VON3 0x00200000 /* R/W VME aligned DMA xfer cnt 512 */
#define DGCS_VON4 0x00300000 /* R/W VME aligned DMA xfer cnt 1024 */
#define DGCS_VON5 0x00400000 /* R/W VME aligned DMA xfer cnt 2048 */
#define DGCS_VON6 0x00500000 /* R/W VME aligned DMA xfer cnt 4096 */
#define DGCS_VON7 0x00600000 /* R/W VME aligned DMA xfer cnt 8192 */
#define DGCS_VON8 0x00700000 /* R/W VME aligned DMA xfer cnt 16384 */
#define DGCS_VOFF1 0x00000000 /* R/W min off between xfers 0 us */
#define DGCS_VOFF2 0x00010000 /* R/W min off between xfers 16 us */
#define DGCS_VOFF3 0x00020000 /* R/W min off between xfers 32 us */
#define DGCS_VOFF4 0x00030000 /* R/W min off between xfers 64 us */
#define DGCS_VOFF5 0x00040000 /* R/W min off between xfers 128 us */
#define DGCS_VOFF6 0x00050000 /* R/W min off between xfers 256 us */
#define DGCS_VOFF7 0x00060000 /* R/W min off between xfers 512 us */
#define DGCS_VOFF8 0x00070000 /* R/W min off between xfers 1024 us */
#define DGCS_VOFF9 0x00080000 /* R/W min off between xfers 2 us */
#define DGCS_VOFFA 0x00090000 /* R/W min off between xfers 4 us */
#define DGCS_VOFFB 0x000A0000 /* R/W min off between xfers 8 us */
#define DGCS_ACT 0x00008000 /* R DMA active flag */
#define DGCS_STOP 0x00004000 /* R/WC DMA stopped flag */
#define DGCS_HALT 0x00002000 /* R/WC DMA halted flag */
#define DGCS_DONE 0x00000800 /* R/WC DMA transfers complete flag */
#define DGCS_LERR 0x00000400 /* R/WC DMA PCI bus error */
#define DGCS_VERR 0x00000200 /* R/WC DMA VMEbus error */
#define DGCS_P_ERR 0x00000100 /* R/WC protocol error */
#define DGCS_INT_STOP 0x00000040 /* R/W interrupt when stopped */
#define DGCS_INT_HALT 0x00000020 /* R/W interrupt when halted */
#define DGCS_INT_DONE 0x00000008 /* R/W interrupt when done */
#define DGCS_INT_LERR 0x00000004 /* R/W interrupt on LERR */
#define DGCS_INT_VERR 0x00000002 /* R/W interrupt on VERR */
#define DGCS_INT_M_ERR 0x00000001 /* R/W interrupt on protocol error */
/* dllue - DMA linked list update enable register */
#define D_LLUE_UPDATE 0x80000000 /* R/W PCI resource updating list */
/* lint_en - PCI interrupt enable register */
#define LINT_EN_LM3 0x00800000 /* R/W Location monitor 3 enable */
#define LINT_EN_LM2 0x00400000 /* R/W Location monitor 2 enable */
#define LINT_EN_LM1 0x00200000 /* R/W Location monitor 1 enable */
#define LINT_EN_LM0 0x00100000 /* R/W Location monitor 0 enable */
#define LINT_EN_MBOX3 0x00080000 /* R/W MAILBOX 3 enable */
#define LINT_EN_MBOX2 0x00040000 /* R/W MAILBOX 2 enable */
#define LINT_EN_MBOX1 0x00020000 /* R/W MAILBOX 1 enable */
#define LINT_EN_MBOX0 0x00010000 /* R/W MAILBOX 0 enable */
#define LINT_EN_ACFALL 0x00008000 /* R/W ACFALL interrupt enable */
#define LINT_EN_SYSFAIL 0x00004000 /* R/W SYSFAIL interrupt enable */
#define LINT_EN_SW_INT 0x00002000 /* R/W PCI software int. enable */
#define LINT_EN_SW_IACK 0x00001000 /* R/W VME software IACK enable */
#define LINT_EN_VERR 0x00000400 /* R/W PCI VERR interrupt enable */
#define LINT_EN_LERR 0x00000200 /* R/W PCI LERR interrupt enable */
#define LINT_EN_DMA 0x00000100 /* R/W PCI DMA interrupt enable */
#define LINT_EN_VIRQ7 0x00000080 /* R/W VIRQ7 interrupt enable */
#define LINT_EN_VIRQ6 0x00000040 /* R/W VIRQ6 interrupt enable */

```

```
#define LINT_EN_VIRQ5 0x00000030 /* R/W VIRQ5 interrupt enable */
#define LINT_EN_VIRQ4 0x00000010 /* R/W VIRQ4 interrupt enable */
#define LINT_EN_VIRQ3 0x00000008 /* R/W VIRQ3 interrupt enable */
#define LINT_EN_VIRQ2 0x00000004 /* R/W VIRQ2 interrupt enable */
#define LINT_EN_VIRQ1 0x00000002 /* R/W VIRQ1 interrupt enable */
#define LINT_EN_VOWN 0x00000001 /* R/W VOWN interrupt enable */
/* lint_stat - PCI interrupt status register */
#define LINT_STAT_LM3 0x00800000 /* R/W Location monitor 3 received */
#define LINT_STAT_LM2 0x00400000 /* R/W Location monitor 2 received */
#define LINT_STAT_LM1 0x00200000 /* R/W Location monitor 1 received */
#define LINT_STAT_LM0 0x00100000 /* R/W Location monitor 0 received */
#define LINT_STAT_MBOX3 0x00080000 /* R/W MAILBOX 3 received */
#define LINT_STAT_MBOX2 0x00040000 /* R/W MAILBOX 2 received */
#define LINT_STAT_MBOX1 0x00020000 /* R/W MAILBOX 1 received */
#define LINT_STAT_MBOX0 0x00010000 /* R/W MAILBOX 0 received */
#define LINT_STAT_ACFAIL 0x00008000 /* R ACFAIL interrupt active */
#define LINT_STAT_SYSFAIL 0x00004000 /* R SYSFAIL interrupt active */
#define LINT_STAT_SW_INT 0x00002000 /* R/WC PCI software int. received */
#define LINT_STAT_SW_IACK 0x00001000 /* R/WC VME software IACK received */
#define LINT_STAT_VERR 0x00000400 /* R/WC PCI VERR interrupt received */
#define LINT_STAT_LERR 0x00000200 /* R/WC PCI LERR interrupt received */
#define LINT_STAT_DMA 0x00000100 /* R/WC PCI DMA interrupt received */
#define LINT_STAT_VIRQ7 0x00000080 /* R/WC VIRQ7 interrupt received */
#define LINT_STAT_VIRQ6 0x00000040 /* R/WC VIRQ6 interrupt received */
#define LINT_STAT_VIRQ5 0x00000030 /* R/WC VIRQ5 interrupt received */
#define LINT_STAT_VIRQ4 0x00000010 /* R/WC VIRQ4 interrupt received */
#define LINT_STAT_VIRQ3 0x00000008 /* R/WC VIRQ3 interrupt received */
#define LINT_STAT_VIRQ2 0x00000004 /* R/WC VIRQ2 interrupt received */
#define LINT_STAT_VIRQ1 0x00000002 /* R/WC VIRQ1 interrupt received */
#define LINT_STAT_VOWN 0x00000001 /* R/WC VOWN interrupt received */
/* lint_map0 - PCI interrupt map 0 register */
#define LINT_MAP0_VIRQ7_0 0x00000000 /* R/W PCI int LINT#0 for VME IRQ7 */
#define LINT_MAP0_VIRQ7_1 0x10000000 /* R/W PCI int LINT#1 for VME IRQ7 */
#define LINT_MAP0_VIRQ7_2 0x20000000 /* R/W PCI int LINT#2 for VME IRQ7 */
#define LINT_MAP0_VIRQ7_3 0x30000000 /* R/W PCI int LINT#3 for VME IRQ7 */
#define LINT_MAP0_VIRQ7_4 0x40000000 /* R/W PCI int LINT#4 for VME IRQ7 */
#define LINT_MAP0_VIRQ7_5 0x50000000 /* R/W PCI int LINT#5 for VME IRQ7 */
#define LINT_MAP0_VIRQ7_6 0x60000000 /* R/W PCI int LINT#6 for VME IRQ7 */
#define LINT_MAP0_VIRQ7_7 0x70000000 /* R/W PCI int LINT#7 for VME IRQ7 */
#define LINT_MAP0_VIRQ6_0 0x00000000 /* R/W PCI int LINT#0 for VME IRQ6 */
#define LINT_MAP0_VIRQ6_1 0x01000000 /* R/W PCI int LINT#1 for VME IRQ6 */
#define LINT_MAP0_VIRQ6_2 0x02000000 /* R/W PCI int LINT#2 for VME IRQ6 */
#define LINT_MAP0_VIRQ6_3 0x03000000 /* R/W PCI int LINT#3 for VME IRQ6 */
#define LINT_MAP0_VIRQ6_4 0x04000000 /* R/W PCI int LINT#4 for VME IRQ6 */
#define LINT_MAP0_VIRQ6_5 0x05000000 /* R/W PCI int LINT#5 for VME IRQ6 */
#define LINT_MAP0_VIRQ6_6 0x06000000 /* R/W PCI int LINT#6 for VME IRQ6 */
#define LINT_MAP0_VIRQ6_7 0x07000000 /* R/W PCI int LINT#7 for VME IRQ6 */
#define LINT_MAP0_VIRQ5_0 0x00000000 /* R/W PCI int LINT#0 for VME IRQ5 */
#define LINT_MAP0_VIRQ5_1 0x00100000 /* R/W PCI int LINT#1 for VME IRQ5 */
#define LINT_MAP0_VIRQ5_2 0x00200000 /* R/W PCI int LINT#2 for VME IRQ5 */
#define LINT_MAP0_VIRQ5_3 0x00300000 /* R/W PCI int LINT#3 for VME IRQ5 */
#define LINT_MAP0_VIRQ5_4 0x00400000 /* R/W PCI int LINT#4 for VME IRQ5 */
#define LINT_MAP0_VIRQ5_5 0x00500000 /* R/W PCI int LINT#5 for VME IRQ5 */
#define LINT_MAP0_VIRQ5_6 0x00600000 /* R/W PCI int LINT#6 for VME IRQ5 */
#define LINT_MAP0_VIRQ5_7 0x00700000 /* R/W PCI int LINT#7 for VME IRQ5 */
#define LINT_MAP0_VIRQ4_0 0x00000000 /* R/W PCI int LINT#0 for VME IRQ4 */
#define LINT_MAP0_VIRQ4_1 0x00010000 /* R/W PCI int LINT#1 for VME IRQ4 */
#define LINT_MAP0_VIRQ4_2 0x00020000 /* R/W PCI int LINT#2 for VME IRQ4 */
#define LINT_MAP0_VIRQ4_3 0x00030000 /* R/W PCI int LINT#3 for VME IRQ4 */
#define LINT_MAP0_VIRQ4_4 0x00040000 /* R/W PCI int LINT#4 for VME IRQ4 */
#define LINT_MAP0_VIRQ4_5 0x00050000 /* R/W PCI int LINT#5 for VME IRQ4 */
#define LINT_MAP0_VIRQ4_6 0x00060000 /* R/W PCI int LINT#6 for VME IRQ4 */
#define LINT_MAP0_VIRQ4_7 0x00070000 /* R/W PCI int LINT#7 for VME IRQ4 */
#define LINT_MAP0_VIRQ3_0 0x00000000 /* R/W PCI int LINT#0 for VME IRQ3 */
#define LINT_MAP0_VIRQ3_1 0x00001000 /* R/W PCI int LINT#1 for VME IRQ3 */
#define LINT_MAP0_VIRQ3_2 0x00002000 /* R/W PCI int LINT#2 for VME IRQ3 */
#define LINT_MAP0_VIRQ3_3 0x00003000 /* R/W PCI int LINT#3 for VME IRQ3 */
#define LINT_MAP0_VIRQ3_4 0x00004000 /* R/W PCI int LINT#4 for VME IRQ3 */
#define LINT_MAP0_VIRQ3_5 0x00005000 /* R/W PCI int LINT#5 for VME IRQ3 */
#define LINT_MAP0_VIRQ3_6 0x00006000 /* R/W PCI int LINT#6 for VME IRQ3 */
#define LINT_MAP0_VIRQ3_7 0x00007000 /* R/W PCI int LINT#7 for VME IRQ3 */
#define LINT_MAP0_VIRQ2_0 0x00000000 /* R/W PCI int LINT#0 for VME IRQ2 */
#define LINT_MAP0_VIRQ2_1 0x00000100 /* R/W PCI int LINT#1 for VME IRQ2 */
#define LINT_MAP0_VIRQ2_2 0x00000200 /* R/W PCI int LINT#2 for VME IRQ2 */
#define LINT_MAP0_VIRQ2_3 0x00000300 /* R/W PCI int LINT#3 for VME IRQ2 */
#define LINT_MAP0_VIRQ2_4 0x00000400 /* R/W PCI int LINT#4 for VME IRQ2 */
#define LINT_MAP0_VIRQ2_5 0x00000500 /* R/W PCI int LINT#5 for VME IRQ2 */
#define LINT_MAP0_VIRQ2_6 0x00000600 /* R/W PCI int LINT#6 for VME IRQ2 */
#define LINT_MAP0_VIRQ2_7 0x00000700 /* R/W PCI int LINT#7 for VME IRQ2 */
```

```

#define LINT_MAP0_VIRQ1_0 0x00000000 /* R/W PCI int LINT#0 for VME IRQ1 */
#define LINT_MAP0_VIRQ1_1 0x00000010 /* R/W PCI int LINT#1 for VME IRQ1 */
#define LINT_MAP0_VIRQ1_2 0x00000020 /* R/W PCI int LINT#2 for VME IRQ1 */
#define LINT_MAP0_VIRQ1_3 0x00000030 /* R/W PCI int LINT#3 for VME IRQ1 */
#define LINT_MAP0_VIRQ1_4 0x00000040 /* R/W PCI int LINT#4 for VME IRQ1 */
#define LINT_MAP0_VIRQ1_5 0x00000050 /* R/W PCI int LINT#5 for VME IRQ1 */
#define LINT_MAP0_VIRQ1_6 0x00000060 /* R/W PCI int LINT#6 for VME IRQ1 */
#define LINT_MAP0_VIRQ1_7 0x00000070 /* R/W PCI int LINT#7 for VME IRQ1 */
#define LINT_MAP0_VOWN_0 0x00000000 /* R/W PCI int LINT#0 for VME OWN */
#define LINT_MAP0_VOWN_1 0x00000001 /* R/W PCI int LINT#1 for VME OWN */
#define LINT_MAP0_VOWN_2 0x00000002 /* R/W PCI int LINT#2 for VME OWN */
#define LINT_MAP0_VOWN_3 0x00000003 /* R/W PCI int LINT#3 for VME OWN */
#define LINT_MAP0_VOWN_4 0x00000004 /* R/W PCI int LINT#4 for VME OWN */
#define LINT_MAP0_VOWN_5 0x00000005 /* R/W PCI int LINT#5 for VME OWN */
#define LINT_MAP0_VOWN_6 0x00000006 /* R/W PCI int LINT#6 for VME OWN */
#define LINT_MAP0_VOWN_7 0x00000007 /* R/W PCI int LINT#7 for VME OWN */
/* lint_map1 - PCI interrupt map 1 register */
#define LINT_MAP1_ACFAIL_0 0x00000000 /* R/W PCI int LINT#0 for ACFAIL */
#define LINT_MAP1_ACFAIL_1 0x10000000 /* R/W PCI int LINT#1 for ACFAIL */
#define LINT_MAP1_ACFAIL_2 0x20000000 /* R/W PCI int LINT#2 for ACFAIL */
#define LINT_MAP1_ACFAIL_3 0x30000000 /* R/W PCI int LINT#3 for ACFAIL */
#define LINT_MAP1_ACFAIL_4 0x40000000 /* R/W PCI int LINT#4 for ACFAIL */
#define LINT_MAP1_ACFAIL_5 0x50000000 /* R/W PCI int LINT#5 for ACFAIL */
#define LINT_MAP1_ACFAIL_6 0x60000000 /* R/W PCI int LINT#6 for ACFAIL */
#define LINT_MAP1_ACFAIL_7 0x70000000 /* R/W PCI int LINT#7 for ACFAIL */
#define LINT_MAP1_SYSFAIL_0 0x00000000 /* R/W PCI int LINT#0 for SYSFAIL */
#define LINT_MAP1_SYSFAIL_1 0x01000000 /* R/W PCI int LINT#1 for SYSFAIL */
#define LINT_MAP1_SYSFAIL_2 0x02000000 /* R/W PCI int LINT#2 for SYSFAIL */
#define LINT_MAP1_SYSFAIL_3 0x03000000 /* R/W PCI int LINT#3 for SYSFAIL */
#define LINT_MAP1_SYSFAIL_4 0x04000000 /* R/W PCI int LINT#4 for SYSFAIL */
#define LINT_MAP1_SYSFAIL_5 0x05000000 /* R/W PCI int LINT#5 for SYSFAIL */
#define LINT_MAP1_SYSFAIL_6 0x06000000 /* R/W PCI int LINT#6 for SYSFAIL */
#define LINT_MAP1_SYSFAIL_7 0x07000000 /* R/W PCI int LINT#7 for SYSFAIL */
#define LINT_MAP1_SW_INT_0 0x00000000 /* R/W PCI int LINT#0 for SW_INT */
#define LINT_MAP1_SW_INT_1 0x00100000 /* R/W PCI int LINT#1 for SW_INT */
#define LINT_MAP1_SW_INT_2 0x00200000 /* R/W PCI int LINT#2 for SW_INT */
#define LINT_MAP1_SW_INT_3 0x00300000 /* R/W PCI int LINT#3 for SW_INT */
#define LINT_MAP1_SW_INT_4 0x00400000 /* R/W PCI int LINT#4 for SW_INT */
#define LINT_MAP1_SW_INT_5 0x00500000 /* R/W PCI int LINT#5 for SW_INT */
#define LINT_MAP1_SW_INT_6 0x00600000 /* R/W PCI int LINT#6 for SW_INT */
#define LINT_MAP1_SW_INT_7 0x00700000 /* R/W PCI int LINT#7 for SW_INT */
#define LINT_MAP1_SW_IACK_0 0x00000000 /* R/W PCI int LINT#0 for SW_IACK */
#define LINT_MAP1_SW_IACK_1 0x00010000 /* R/W PCI int LINT#1 for SW_IACK */
#define LINT_MAP1_SW_IACK_2 0x00020000 /* R/W PCI int LINT#2 for SW_IACK */
#define LINT_MAP1_SW_IACK_3 0x00030000 /* R/W PCI int LINT#3 for SW_IACK */
#define LINT_MAP1_SW_IACK_4 0x00040000 /* R/W PCI int LINT#4 for SW_IACK */
#define LINT_MAP1_SW_IACK_5 0x00050000 /* R/W PCI int LINT#5 for SW_IACK */
#define LINT_MAP1_SW_IACK_6 0x00060000 /* R/W PCI int LINT#6 for SW_IACK */
#define LINT_MAP1_SW_IACK_7 0x00070000 /* R/W PCI int LINT#7 for SW_IACK */
#define LINT_MAP1_VERR_0 0x00000000 /* R/W PCI int LINT#0 for VERR */
#define LINT_MAP1_VERR_1 0x00000100 /* R/W PCI int LINT#1 for VERR */
#define LINT_MAP1_VERR_2 0x00000200 /* R/W PCI int LINT#2 for VERR */
#define LINT_MAP1_VERR_3 0x00000300 /* R/W PCI int LINT#3 for VERR */
#define LINT_MAP1_VERR_4 0x00000400 /* R/W PCI int LINT#4 for VERR */
#define LINT_MAP1_VERR_5 0x00000500 /* R/W PCI int LINT#5 for VERR */
#define LINT_MAP1_VERR_6 0x00000600 /* R/W PCI int LINT#6 for VERR */
#define LINT_MAP1_VERR_7 0x00000700 /* R/W PCI int LINT#7 for VERR */
#define LINT_MAP1_LERR_0 0x00000000 /* R/W PCI int LINT#0 for LERR */
#define LINT_MAP1_LERR_1 0x00000010 /* R/W PCI int LINT#1 for LERR */
#define LINT_MAP1_LERR_2 0x00000020 /* R/W PCI int LINT#2 for LERR */
#define LINT_MAP1_LERR_3 0x00000030 /* R/W PCI int LINT#3 for LERR */
#define LINT_MAP1_LERR_4 0x00000040 /* R/W PCI int LINT#4 for LERR */
#define LINT_MAP1_LERR_5 0x00000050 /* R/W PCI int LINT#5 for LERR */
#define LINT_MAP1_LERR_6 0x00000060 /* R/W PCI int LINT#6 for LERR */
#define LINT_MAP1_LERR_7 0x00000070 /* R/W PCI int LINT#7 for LERR */
#define LINT_MAP1_DMA_0 0x00000000 /* R/W PCI int LINT#0 for DMA */
#define LINT_MAP1_DMA_1 0x00000001 /* R/W PCI int LINT#1 for DMA */
#define LINT_MAP1_DMA_2 0x00000002 /* R/W PCI int LINT#2 for DMA */
#define LINT_MAP1_DMA_3 0x00000003 /* R/W PCI int LINT#3 for DMA */
#define LINT_MAP1_DMA_4 0x00000004 /* R/W PCI int LINT#4 for DMA */
#define LINT_MAP1_DMA_5 0x00000005 /* R/W PCI int LINT#5 for DMA */
#define LINT_MAP1_DMA_6 0x00000006 /* R/W PCI int LINT#6 for DMA */
#define LINT_MAP1_DMA_7 0x00000007 /* R/W PCI int LINT#7 for DMA */
/* vint_en - VMEbus interrupt enable register */
#define VINT_EN_SW7 0x80000000 /* R/W enable VMEbus int SW7 */
#define VINT_EN_SW6 0x40000000 /* R/W enable VMEbus int SW6 */
#define VINT_EN_SW5 0x20000000 /* R/W enable VMEbus int SW5 */
#define VINT_EN_SW4 0x10000000 /* R/W enable VMEbus int SW4 */
#define VINT_EN_SW3 0x08000000 /* R/W enable VMEbus int SW3 */

```

```

#define VINT_EN_SW2 0x04000000 /* R/W enable VMEbus int SW2 */
#define VINT_EN_SW1 0x02000000 /* R/W enable VMEbus int SW1 */
#define VINT_EN_MBOX3 0x00080000 /* R/W enable VMEbus int MAILBOX 3 */
#define VINT_EN_MBOX2 0x00040000 /* R/W enable VMEbus int MAILBOX 2 */
#define VINT_EN_MBOX1 0x00020000 /* R/W enable VMEbus int MAILBOX 1 */
#define VINT_EN_MBOX0 0x00010000 /* R/W enable VMEbus int MAILBOX 0 */
#define VINT_EN_SW_IACK 0x00001000 /* R/W enable VMEbus int SW_IACK */
#define VINT_EN_VERR 0x00000400 /* R/W enable PCIbus int VERR */
#define VINT_EN_LERR 0x00000200 /* R/W enable PCIbus int LERR */
#define VINT_EN_DMA 0x00000100 /* R/W enable PCIbus int DMA */
#define VINT_EN_LINT7 0x00000080 /* R/W enable PCIbus int LINT7 */
#define VINT_EN_LINT6 0x00000040 /* R/W enable PCIbus int LINT6 */
#define VINT_EN_LINT5 0x00000020 /* R/W enable PCIbus int LINT5 */
#define VINT_EN_LINT4 0x00000010 /* R/W enable PCIbus int LINT4 */
#define VINT_EN_LINT3 0x00000008 /* R/W enable PCIbus int LINT3 */
#define VINT_EN_LINT2 0x00000004 /* R/W enable PCIbus int LINT2 */
#define VINT_EN_LINT1 0x00000002 /* R/W enable PCIbus int LINT1 */
#define VINT_EN_LINT0 0x00000001 /* R/W enable PCIbus int LINT0 */
/* vint_stat - VMEbus interrupt status register */
#define VINT_STAT_SW7 0x80000000 /* R/W VMEbus int SW7 */
#define VINT_STAT_SW6 0x40000000 /* R/W VMEbus int SW6 */
#define VINT_STAT_SW5 0x20000000 /* R/W VMEbus int SW5 */
#define VINT_STAT_SW4 0x10000000 /* R/W VMEbus int SW4 */
#define VINT_STAT_SW3 0x08000000 /* R/W VMEbus int SW3 */
#define VINT_STAT_SW2 0x04000000 /* R/W VMEbus int SW2 */
#define VINT_STAT_SW1 0x02000000 /* R/W VMEbus int SW1 */
#define VINT_STAT_MBOX3 0x00080000 /* R/W VMEbus int MAILBOX 3 */
#define VINT_STAT_MBOX2 0x00040000 /* R/W VMEbus int MAILBOX 2 */
#define VINT_STAT_MBOX1 0x00020000 /* R/W VMEbus int MAILBOX 1 */
#define VINT_STAT_MBOX0 0x00010000 /* R/W VMEbus int MAILBOX 0 */
#define VINT_STAT_SW_IACK 0x00001000 /* R/W VMEbus int SW_IACK */
#define VINT_STAT_VERR 0x00000400 /* R/W VMEbus int VERR */
#define VINT_STAT_LERR 0x00000200 /* R/W VMEbus int LERR */
#define VINT_STAT_DMA 0x00000100 /* R/W VMEbus int DMA */
#define VINT_STAT_LINT7 0x00000080 /* R/W VMEbus int LINT7 */
#define VINT_STAT_LINT6 0x00000040 /* R/W VMEbus int LINT6 */
#define VINT_STAT_LINT5 0x00000020 /* R/W VMEbus int LINT5 */
#define VINT_STAT_LINT4 0x00000010 /* R/W VMEbus int LINT4 */
#define VINT_STAT_LINT3 0x00000008 /* R/W VMEbus int LINT3 */
#define VINT_STAT_LINT2 0x00000004 /* R/W VMEbus int LINT2 */
#define VINT_STAT_LINT1 0x00000002 /* R/W VMEbus int LINT1 */
#define VINT_STAT_LINT0 0x00000001 /* R/W VMEbus int LINT0 */
/* vint_map0 - VME interrupt map 0 register */
#define VINT_MAP0_LINT7_D 0x00000000 /* R/W VME int disable for LINT7 */
#define VINT_MAP0_LINT7_1 0x10000000 /* R/W VME int 1 for LINT7 */
#define VINT_MAP0_LINT7_2 0x20000000 /* R/W VME int 2 for LINT7 */
#define VINT_MAP0_LINT7_3 0x30000000 /* R/W VME int 3 for LINT7 */
#define VINT_MAP0_LINT7_4 0x40000000 /* R/W VME int 4 for LINT7 */
#define VINT_MAP0_LINT7_5 0x50000000 /* R/W VME int 5 for LINT7 */
#define VINT_MAP0_LINT7_6 0x60000000 /* R/W VME int 6 for LINT7 */
#define VINT_MAP0_LINT7_7 0x70000000 /* R/W VME int 7 for LINT7 */
#define VINT_MAP0_LINT6_D 0x00000000 /* R/W VME int disable for LINT6 */
#define VINT_MAP0_LINT6_1 0x01000000 /* R/W VME int 1 for LINT6 */
#define VINT_MAP0_LINT6_2 0x02000000 /* R/W VME int 2 for LINT6 */
#define VINT_MAP0_LINT6_3 0x03000000 /* R/W VME int 3 for LINT6 */
#define VINT_MAP0_LINT6_4 0x04000000 /* R/W VME int 4 for LINT6 */
#define VINT_MAP0_LINT6_5 0x05000000 /* R/W VME int 5 for LINT6 */
#define VINT_MAP0_LINT6_6 0x06000000 /* R/W VME int 6 for LINT6 */
#define VINT_MAP0_LINT6_7 0x07000000 /* R/W VME int 7 for LINT6 */
#define VINT_MAP0_LINT5_D 0x00000000 /* R/W VME int disable for LINT5 */
#define VINT_MAP0_LINT5_1 0x00100000 /* R/W VME int 1 for LINT5 */
#define VINT_MAP0_LINT5_2 0x00200000 /* R/W VME int 2 for LINT5 */
#define VINT_MAP0_LINT5_3 0x00300000 /* R/W VME int 3 for LINT5 */
#define VINT_MAP0_LINT5_4 0x00400000 /* R/W VME int 4 for LINT5 */
#define VINT_MAP0_LINT5_5 0x00500000 /* R/W VME int 5 for LINT5 */
#define VINT_MAP0_LINT5_6 0x00600000 /* R/W VME int 6 for LINT5 */
#define VINT_MAP0_LINT5_7 0x00700000 /* R/W VME int 7 for LINT5 */
#define VINT_MAP0_LINT4_D 0x00000000 /* R/W VME int disable for LINT4 */
#define VINT_MAP0_LINT4_1 0x00010000 /* R/W VME int 1 for LINT4 */
#define VINT_MAP0_LINT4_2 0x00020000 /* R/W VME int 2 for LINT4 */
#define VINT_MAP0_LINT4_3 0x00030000 /* R/W VME int 3 for LINT4 */
#define VINT_MAP0_LINT4_4 0x00040000 /* R/W VME int 4 for LINT4 */
#define VINT_MAP0_LINT4_5 0x00050000 /* R/W VME int 5 for LINT4 */
#define VINT_MAP0_LINT4_6 0x00060000 /* R/W VME int 6 for LINT4 */
#define VINT_MAP0_LINT4_7 0x00070000 /* R/W VME int 7 for LINT4 */
#define VINT_MAP0_LINT3_D 0x00000000 /* R/W VME int disable for LINT3 */
#define VINT_MAP0_LINT3_1 0x00001000 /* R/W VME int 1 for LINT3 */
#define VINT_MAP0_LINT3_2 0x00002000 /* R/W VME int 2 for LINT3 */
#define VINT_MAP0_LINT3_3 0x00003000 /* R/W VME int 3 for LINT3 */

```

```

#define VINT_MAP0_LINT3_4 0x00004000 /* R/W VME int 4 for LINT3 */
#define VINT_MAP0_LINT3_5 0x00005000 /* R/W VME int 5 for LINT3 */
#define VINT_MAP0_LINT3_6 0x00006000 /* R/W VME int 6 for LINT3 */
#define VINT_MAP0_LINT3_7 0x00007000 /* R/W VME int 7 for LINT3 */
#define VINT_MAP0_LINT2_D 0x00000000 /* R/W VME int disable for LINT2 */
#define VINT_MAP0_LINT2_1 0x00000100 /* R/W VME int 1 for LINT2 */
#define VINT_MAP0_LINT2_2 0x00000200 /* R/W VME int 2 for LINT2 */
#define VINT_MAP0_LINT2_3 0x00000300 /* R/W VME int 3 for LINT2 */
#define VINT_MAP0_LINT2_4 0x00000400 /* R/W VME int 4 for LINT2 */
#define VINT_MAP0_LINT2_5 0x00000500 /* R/W VME int 5 for LINT2 */
#define VINT_MAP0_LINT2_6 0x00000600 /* R/W VME int 6 for LINT2 */
#define VINT_MAP0_LINT2_7 0x00000700 /* R/W VME int 7 for LINT2 */
#define VINT_MAP0_LINT1_D 0x00000000 /* R/W VME int disable for LINT1 */
#define VINT_MAP0_LINT1_1 0x00000010 /* R/W VME int 1 for LINT1 */
#define VINT_MAP0_LINT1_2 0x00000020 /* R/W VME int 2 for LINT1 */
#define VINT_MAP0_LINT1_3 0x00000030 /* R/W VME int 3 for LINT1 */
#define VINT_MAP0_LINT1_4 0x00000040 /* R/W VME int 4 for LINT1 */
#define VINT_MAP0_LINT1_5 0x00000050 /* R/W VME int 5 for LINT1 */
#define VINT_MAP0_LINT1_6 0x00000060 /* R/W VME int 6 for LINT1 */
#define VINT_MAP0_LINT1_7 0x00000070 /* R/W VME int 7 for LINT1 */
#define VINT_MAP0_LINT0_D 0x00000000 /* R/W VME int disable for LINT0 */
#define VINT_MAP0_LINT0_1 0x00000001 /* R/W VME int 1 for LINT0 */
#define VINT_MAP0_LINT0_2 0x00000002 /* R/W VME int 2 for LINT0 */
#define VINT_MAP0_LINT0_3 0x00000003 /* R/W VME int 3 for LINT0 */
#define VINT_MAP0_LINT0_4 0x00000004 /* R/W VME int 4 for LINT0 */
#define VINT_MAP0_LINT0_5 0x00000005 /* R/W VME int 5 for LINT0 */
#define VINT_MAP0_LINT0_6 0x00000006 /* R/W VME int 6 for LINT0 */
#define VINT_MAP0_LINT0_7 0x00000007 /* R/W VME int 7 for LINT0 */
/* vint_map1 - VME interrupt map 1 register */
#define VINT_MAP1_SW_IACK_D 0x00000000 /* R/W VME int disable for SW_IACK */
#define VINT_MAP1_SW_IACK_1 0x00010000 /* R/W VME int 1 for SW_IACK */
#define VINT_MAP1_SW_IACK_2 0x00020000 /* R/W VME int 2 for SW_IACK */
#define VINT_MAP1_SW_IACK_3 0x00030000 /* R/W VME int 3 for SW_IACK */
#define VINT_MAP1_SW_IACK_4 0x00040000 /* R/W VME int 4 for SW_IACK */
#define VINT_MAP1_SW_IACK_5 0x00050000 /* R/W VME int 5 for SW_IACK */
#define VINT_MAP1_SW_IACK_6 0x00060000 /* R/W VME int 6 for SW_IACK */
#define VINT_MAP1_SW_IACK_7 0x00070000 /* R/W VME int 7 for SW_IACK */
#define VINT_MAP1_VERR_D 0x00000000 /* R/W VME int disable for VERR */
#define VINT_MAP1_VERR_1 0x00000100 /* R/W VME int 1 for VERR */
#define VINT_MAP1_VERR_2 0x00000200 /* R/W VME int 2 for VERR */
#define VINT_MAP1_VERR_3 0x00000300 /* R/W VME int 3 for VERR */
#define VINT_MAP1_VERR_4 0x00000400 /* R/W VME int 4 for VERR */
#define VINT_MAP1_VERR_5 0x00000500 /* R/W VME int 5 for VERR */
#define VINT_MAP1_VERR_6 0x00000600 /* R/W VME int 6 for VERR */
#define VINT_MAP1_VERR_7 0x00000700 /* R/W VME int 7 for VERR */
#define VINT_MAP1_LERR_D 0x00000000 /* R/W VME int disable for LERR */
#define VINT_MAP1_LERR_1 0x00000010 /* R/W VME int 1 for LERR */
#define VINT_MAP1_LERR_2 0x00000020 /* R/W VME int 2 for LERR */
#define VINT_MAP1_LERR_3 0x00000030 /* R/W VME int 3 for LERR */
#define VINT_MAP1_LERR_4 0x00000040 /* R/W VME int 4 for LERR */
#define VINT_MAP1_LERR_5 0x00000050 /* R/W VME int 5 for LERR */
#define VINT_MAP1_LERR_6 0x00000060 /* R/W VME int 6 for LERR */
#define VINT_MAP1_LERR_7 0x00000070 /* R/W VME int 7 for LERR */
#define VINT_MAP1_DMA_D 0x00000000 /* R/W VME int disable for LERR */
#define VINT_MAP1_DMA_1 0x00000001 /* R/W VME int 1 for DMA */
#define VINT_MAP1_DMA_2 0x00000002 /* R/W VME int 2 for DMA */
#define VINT_MAP1_DMA_3 0x00000003 /* R/W VME int 3 for DMA */
#define VINT_MAP1_DMA_4 0x00000004 /* R/W VME int 4 for DMA */
#define VINT_MAP1_DMA_5 0x00000005 /* R/W VME int 5 for DMA */
#define VINT_MAP1_DMA_6 0x00000006 /* R/W VME int 6 for DMA */
#define VINT_MAP1_DMA_7 0x00000007 /* R/W VME int 7 for DMA */
/* statid - interrupt STATUS/ID OUT 0x00XXXXXX */
#define STATID 0xFF000000 /* R/W interrupt status/ID out MASK */
/* v1_statid - R VIRQ1 STATUS/ID register 0xXXXXXX00 */
/* v2_statid - R VIRQ2 STATUS/ID register 0xXXXXXX00 */
/* v3_statid - R VIRQ3 STATUS/ID register 0xXXXXXX00 */
/* v4_statid - R VIRQ4 STATUS/ID register 0xXXXXXX00 */
/* v5_statid - R VIRQ5 STATUS/ID register 0xXXXXXX00 */
/* v6_statid - R VIRQ6 STATUS/ID register 0xXXXXXX00 */
/* v7_statid - R VIRQ7 STATUS/ID register 0xXXXXXX00 */
#define VX_STATID_ERR 0x00000100 /* R VME BERR* occurred during IACK */
#define VX_STATID_ID 0x000000FF /* R VME status/ID MASK */
/* lint_map2 - local interrupt Map 2 register */
#define LINT_MAP2_LM3_0 0x00000000 /* R/W PCI int LINT#0 for LOC MON3 */
#define LINT_MAP2_LM3_1 0x10000000 /* R/W PCI int LINT#1 for LOC MON3 */
#define LINT_MAP2_LM3_2 0x20000000 /* R/W PCI int LINT#2 for LOC MON3 */
#define LINT_MAP2_LM3_3 0x30000000 /* R/W PCI int LINT#3 for LOC MON3 */
#define LINT_MAP2_LM3_4 0x40000000 /* R/W PCI int LINT#4 for LOC MON3 */
#define LINT_MAP2_LM3_5 0x50000000 /* R/W PCI int LINT#5 for LOC MON3 */

```



```

#define VINT_MAP2_MB1_7 0x00000070 /* R/W VME int VIRQ#7 for MAILBOX1 */
#define VINT_MAP2_MB0_1 0x00000001 /* R/W VME int VIRQ#1 for MAILBOX0 */
#define VINT_MAP2_MB0_2 0x00000002 /* R/W VME int VIRQ#2 for MAILBOX0 */
#define VINT_MAP2_MB0_3 0x00000003 /* R/W VME int VIRQ#3 for MAILBOX0 */
#define VINT_MAP2_MB0_4 0x00000004 /* R/W VME int VIRQ#4 for MAILBOX0 */
#define VINT_MAP2_MB0_5 0x00000005 /* R/W VME int VIRQ#5 for MAILBOX0 */
#define VINT_MAP2_MB0_6 0x00000006 /* R/W VME int VIRQ#6 for MAILBOX0 */
#define VINT_MAP2_MB0_7 0x00000007 /* R/W VME int VIRQ#7 for MAILBOX0 */
/* sema0 - semaphore 0 register */
#define SEMA0_SEM3 0x80000000 /* R/W semaphore 3 */
#define SEMA0_SEM2 0x00800000 /* R/W semaphore 2 */
#define SEMA0_SEM1 0x00008000 /* R/W semaphore 1 */
#define SEMA0_SEM0 0x00000080 /* R/W semaphore 0 */
/* semal - semaphore 1 register */
#define SEMA1_SEM7 0x80000000 /* R/W semaphore 7 */
#define SEMA1_SEM6 0x00800000 /* R/W semaphore 6 */
#define SEMA1_SEM5 0x00008000 /* R/W semaphore 5 */
#define SEMA1_SEM4 0x00000080 /* R/W semaphore 4 */
/* mast_ctl - master control register */
#define MAST_CTL_MRTRY_M 0xF0000000 /* Max PCI retries */
#define MAST_CTL_PWON_0 0x00000000 /* R/W posted write xfer count 128 */
#define MAST_CTL_PWON_1 0x01000000 /* R/W posted write xfer count 256 */
#define MAST_CTL_PWON_2 0x02000000 /* R/W posted write xfer count 512 */
#define MAST_CTL_PWON_3 0x03000000 /* R/W posted write xfer count 1024 */
#define MAST_CTL_PWON_4 0x04000000 /* R/W posted write xfer count 2048 */
#define MAST_CTL_PWON_5 0x05000000 /* R/W posted write xfer count 4096 */
#define MAST_CTL_PWBBSY 0xF0000000 /* R/W posted write xfer count BUSY */
#define MAST_CTL_VRL_0 0x00000000 /* R/W VMEbus request level 0 */
#define MAST_CTL_VRL_1 0x00400000 /* R/W VMEbus request level 1 */
#define MAST_CTL_VRL_2 0x00800000 /* R/W VMEbus request level 2 */
#define MAST_CTL_VRL_3 0x00C00000 /* R/W VMEbus request level 3 */
#define MAST_CTL_VRM_D 0x00000000 /* R/W VMEbus request mode demand */
#define MAST_CTL_VRM_F 0x00200000 /* R/W VMEbus request mode fair */
#define MAST_CTL_VREL_R 0x00100000 /* R/W VMEbus request mode ROR */
#define MAST_CTL_VREL_D 0x00000000 /* R/W VMEbus request mode RWD */
#define MAST_CTL_VOWN_R 0x00000000 /* W VMEbus ownership release */
#define MAST_CTL_VOWN_H 0x00080000 /* W VMEbus ownership hold */
#define MAST_CTL_VOWN_ACK 0x00040000 /* R VMEbus ownership due to hold */
#define MAST_CTL_PABS_32 0x00000000 /* R/W PCI aligned burst size 32 */
#define MAST_CTL_PABS_64 0x00001000 /* R/W PCI aligned burst size 64 */
#define MAST_CTL_PABS_128 0x00002000 /* R/W PCI aligned burst size 128 */
#define MAST_CTL_BUS_NO 0x000000FF /* R/W PCI bus number MASK */
/* misc_ctl - miscellaneous control register */
#define MISC_CTL_VBTO_0 0x00000000 /* R/W VME bus time out disable */
#define MISC_CTL_VBTO_1 0x10000000 /* R/W VME bus time out 16 us */
#define MISC_CTL_VBTO_2 0x20000000 /* R/W VME bus time out 32 us */
#define MISC_CTL_VBTO_3 0x30000000 /* R/W VME bus time out 64 us */
#define MISC_CTL_VBTO_4 0x40000000 /* R/W VME bus time out 128 us */
#define MISC_CTL_VBTO_5 0x50000000 /* R/W VME bus time out 256 us */
#define MISC_CTL_VBTO_6 0x60000000 /* R/W VME bus time out 512 us */
#define MISC_CTL_VBTO_7 0x70000000 /* R/W VME bus time out 1024 us */
#define MISC_CTL_VARB_R 0x00000000 /* R/W VME arbitration Round Robin */
#define MISC_CTL_VARB_P 0x04000000 /* R/W VME arbitration Priority */
#define MISC_CTL_VARBTO_1 0x00000000 /* R/W VME arb. time out disabled */
#define MISC_CTL_VARBTO_2 0x01000000 /* R/W VME arb. time out 16 us */
#define MISC_CTL_VARBTO_3 0x02000000 /* R/W VME arb. time out 256 us */
#define MISC_CTL_SW_LRST 0x00800000 /* W software PCI reset */
#define MISC_CTL_SW_SRST 0x00400000 /* W software VME sysrest */
#define MISC_CTL_BI 0x00100000 /* R/W universe in BI-Mode */
#define MISC_CTL_ENGBI 0x00080000 /* R/W enable global BI initiator */
#define MISC_CTL_RESCIND 0x00040000 /* R/W enable rescinding DTACK */
#define MISC_CTL_SYSCON 0x00020000 /* R/W universe is sys controller */
#define MISC_CTL_V64AUTO 0x00010000 /* R/W initiate VME64 auto ID slave */
/* misc_stat - miscellaneous status register */
#define MISC_STAT_ENDIAN 0x80000000 /* R always little endian mode */
#define MISC_STAT_LCLSIZE_32 0x00000000 /* R PCI bus size 32 bits */
#define MISC_STAT_LCLSIZE_64 0x40000000 /* R PCI bus size 64 bits */
#define MISC_STAT_DY4AUTO 0x08000000 /* R DY4 auto ID enable */
#define MISC_STAT_MYBBSY 0x00200000 /* R universe NOT busy */
#define MISC_STAT_DY4DONE 0x00080000 /* R DY4 auto ID done */
#define MISC_STAT_TXFE 0x00040000 /* R transmit FIFO empty */
#define MISC_STAT_RXFE 0x00020000 /* R receive FIFO empty */
/* user_am - user AM codes register */
#define USER_AM_1 0xFC000000 /* R/W user1 AM code MASK */
#define USER_AM_2 0x0FC00000 /* R/W user2 AM code MASK */
/* vsi[x]_ctl - VMEbus slave image 0 control register */
#define VSI_CTL_EN 0x80000000 /* R/W image enable */
#define VSI_CTL_PWEN 0x40000000 /* R/W posted write enable */
#define VSI_CTL_PREN 0x20000000 /* R/W prefetch read enable */

```

```

#define VSI_CTL_AM_D 0x00400000 /* R/W AM code - data */
#define VSI_CTL_AM_P 0x00800000 /* R/W AM code - program */
#define VSI_CTL_AM_DP 0x00C00000 /* R/W AM code - both data & program */
#define VSI_CTL_AM_U 0x00100000 /* R/W AM code - non priv */
#define VSI_CTL_AM_S 0x00200000 /* R/W AM code - supervisory */
#define VSI_CTL_AM_SU 0x00300000 /* R/W AM code - both user & super */
#define VSI_CTL_VAS_16 0x00000000 /* R/W address space A16 */
#define VSI_CTL_VAS_24 0x00010000 /* R/W address space A24 */
#define VSI_CTL_VAS_32 0x00020000 /* R/W address space A32 */
#define VSI_CTL_VAS_R1 0x00030000 /* R/W address space reserved 1 */
#define VSI_CTL_VAS_R2 0x00040000 /* R/W address space reserved 2 */
#define VSI_CTL_VAS_R3 0x00050000 /* R/W address space reserved 3 */
#define VSI_CTL_VAS_U1 0x00060000 /* R/W address space user 1 */
#define VSI_CTL_VAS_U2 0x00070000 /* R/W address space user 2 */
#define VSI_CTL_LD64EN 0x00000080 /* R/W enable 64 bit PCIbus xfers */
#define VSI_CTL_LLRMW 0x00000040 /* R/W enable PCIbus lock of VME RMW */
#define VSI_CTL_LAS_M 0x00000000 /* R/W PCIbus memory space */
#define VSI_CTL_LAS_I 0x00000001 /* R/W PCIbus I/O space */
#define VSI_CTL_LAS_C 0x00000002 /* R/W PCIbus configuration space */
/* vsi[x]_bs - VMEbus slave image 0 base address register */
#define VSI0_BS 0xFFFF0000 /* R/W VME slave image 0 base add MASK */
#define VSI1_BS 0xFFFF0000 /* R/W VME slave image 1 base add MASK */
#define VSI2_BS 0xFFFF0000 /* R/W VME slave image 2 base add MASK */
#define VSI3_BS 0xFFFF0000 /* R/W VME slave image 3 base add MASK */

/* vsi[x]_bd - VMEbus slave image 0 bound address register */
#define VSI0_BD 0xFFFF0000 /* R/W VME slave image 0 bound add MASK */
#define VSI1_BD 0xFFFF0000 /* R/W VME slave image 1 bound add MASK */
#define VSI2_BD 0xFFFF0000 /* R/W VME slave image 2 bound add MASK */
#define VSI3_BD 0xFFFF0000 /* R/W VME slave image 3 bound add MASK */
/* vsi[x]_to - VMEbus slave image 0 translation offset register */
#define VSI0_TO 0xFFFF0000 /* R/W VME slave image 0 offset MASK */
#define VSI1_TO 0xFFFF0000 /* R/W VME slave image 1 offset MASK */
#define VSI2_TO 0xFFFF0000 /* R/W VME slave image 2 offset MASK */
#define VSI3_TO 0xFFFF0000 /* R/W VME slave image 3 offset MASK */
/* lm_ctl - location monitor control */
#define LM_CTL_EN 0x80000000 /* R/W location monitor enable */
#define LM_CTL_AM_D 0x00400000 /* R/W location monitor AM = DATA */
#define LM_CTL_AM_P 0x00800000 /* R/W location monitor AM = PROGRAM */
#define LM_CTL_AM_DP 0x00C00000 /* R/W location monitor AM = BOTH */
#define LM_CTL_AM_U 0x00100000 /* R/W location monitor AM = USER */
#define LM_CTL_AM_S 0x00200000 /* R/W location monitor AM = SUPER */
#define LM_CTL_AM_SU 0x00300000 /* R/W location monitor AM = BOTH */
#define LM_CTL_AM_16 0x00000000 /* R/W location monitor AM = A16 */
#define LM_CTL_AM_24 0x00010000 /* R/W location monitor AM = A24 */
#define LM_CTL_AM_32 0x00020000 /* R/W location monitor AM = A32 */
/* vra_i_ctl - VMEbus register access image control register */
#define VRAI_CTL_EN 0x80000000 /* R/W image enable */
#define VRAI_CTL_AM_D 0x00400000 /* R/W AM code - data */
#define VRAI_CTL_AM_P 0x00800000 /* R/W AM code - program */
#define VRAI_CTL_AM_DP 0x00C00000 /* R/W AM code - both */
#define VRAI_CTL_AM_U 0x00100000 /* R/W AM code - non priv */
#define VRAI_CTL_AM_S 0x00200000 /* R/W AM code - supervisory */
#define VRAI_CTL_AM_US 0x00300000 /* R/W AM code - both */
#define VRAI_CTL_VAS_16 0x00000000 /* R/W address space A16 */
#define VRAI_CTL_VAS_24 0x00010000 /* R/W address space A24 */
#define VRAI_CTL_VAS_32 0x00020000 /* R/W address space A32 */
/* vra_i_bs - VMEbus register access image base address register */
#define VRAI_BS 0xFFFF0000 /* R/W VME reg access image base add MASK */
/* vcsr_ctl - VMEbus CSR control register */
#define VCSR_CTL_EN 0x80000000 /* R image enable */
#define VCSR_CTL_LAS_M 0x00000000 /* R/W PCIbus memory space */
#define VCSR_CTL_LAS_I 0x00000001 /* R/W PCIbus I/O space */
#define VCSR_CTL_LAS_C 0x00000002 /* R/W PCIbus configuration space */
/* vcsr_to - VMEbus CSR translation offset */
#define VCSR_TO 0xFFF80000 /* R/W VME CSR translation offset MASK */
/* v_amerr - VMEbus AM code error log */
#define V_AMERR_AMERR 0xFC000000 /* R AM codes for error log MASK */
#define V_AMERR_IACK 0x02000000 /* R VMEbus IACK */
#define V_AMERR_M_ERR 0x01000000 /* R multiple errors occurred */
#define V_AMERR_V_STAT 0x00800000 /* R/W VME error logs are valid */

```

```
/* vaerr - VMEbus address error log */
#define VAERR 0xFFFFFFFF /* R VMEbus address error log MASK */
/* vcsr_clr - VMEbus CSR bit clear register */
#define VCSR_CLR_RESET 0x80000000 /* R/W board reset */
#define VCSR_CLR_SYSFAIL 0x40000000 /* R/W VMEbus sysfail */
#define VCSR_CLR_FAIL 0x20000000 /* R board fail */
/* vcsr_set - VMEbus CSR bit set register */
#define VCSR_SET_RESET 0x80000000 /* R/W board reset */
#define VCSR_SET_SYSFAIL 0x40000000 /* R/W VMEbus sysfail */
#define VCSR_SET_FAIL 0x20000000 /* R board fail */
/* vcsr_bs - VMEbus CSR base address register */
#define VCSR_BS 0xF8000000 /* R/W VME CSR base add MASK */
```

## Directory SRAM

The file in this directory can be used to test the integrity of the battery backed SRAM.

Because of the wide variety of environments in which the VMEbus CPU operates, the samples provided in this appendix are not intended to be used verbatim. Rather, they are intended to provide the end user an example of the standard structure of the operating code.

### \*\* FILE: TS.C

```

/*****
/* FILE: TS.C
/*
/* Test battery backed SRAM with patterns and data=address.
/*
/*
/*****
#include <stdlib.h>
#include <stdio.h>
#include <dos.h>
unsigned char far * b_ptr;
unsigned int far * w_ptr;
unsigned long far * l_ptr;
unsigned int far * buf_ptr;
static unsigned long pat[4] = {
    0x55555555,
    0xCCCCCCCC,
    0x66666666,
    0xFFFFFFFF
};
void main( void ) {
    unsigned long i, x;
    unsigned char bdat;
    unsigned char brd;
    unsigned int wdat;
    unsigned int wrd;
    unsigned long ldat;
    unsigned long lrd;
    printf("\nTesting 32K SRAM DATA/~DATA B/W/L/ADDR .....");
    buf_ptr = (unsigned int far *) MK_FP( 0xD800, 0x18 );
    /* fill and test buf with DATA/~DATA BYTES 4 patterns */
    for( x = 0; x < 4; x++ ) {
        b_ptr = (unsigned char far *) buf_ptr;
        bdat = (unsigned char) pat[x];
        for( i = 0x18; i < 0x8000; i++ ) {
            *b_ptr++ = bdat;
            bdat = ~bdat;
        }
        b_ptr = (unsigned char far *) buf_ptr;
        bdat = (unsigned char) pat[x];
        for( i = 0x18; i < 0x8000; i++ ) {
            brd = *b_ptr++;
            if( bdat != brd ) {
                printf("FAILED\nBYTE DATA @ ADDR: %Fp WR: %.2X RD: %.2X\n",
                    --b_ptr, bdat, brd );
                exit( 1 );
            }
            bdat = (~bdat) & 0xFF;
        }
    }
    /* fill and test buf with DATA/~DATA WORDS 4 patterns */
    for( x = 0; x < 4; x++ ) {
        w_ptr = (unsigned int far *) buf_ptr;
        wdat = (unsigned int) pat[x];
        for( i = 0x18; i < 0x8000; i+=2 ) {
            *w_ptr++ = wdat;
            wdat = ~wdat;
        }
    }
}

```

```

    }
    w_ptr = (unsigned int far *) buf_ptr;
    wdat = (unsigned int) pat[x];
    for( i = 0x18; i < 0x8000; i+=2 ) {
        wrd = *w_ptr++;
        if( wdat != wrd ) {
            printf("FAILED\nWORD DATA @ ADDR: %Fp WR: %.4X RD: %.4X\n",
                --w_ptr, wdat, wrd );
            exit( 1 );
        }
        wdat = ~wdat;
    }
}
/* fill and test buf with DATA/~DATA LONGS 4 patterns */
for( x = 0; x < 4; x++ ) {
    l_ptr = (unsigned long far *) MK_FP( 0xD800, 0x18 );
    ldat = (unsigned long) pat[x];
    for( i = 0x18; i < 0x8000; i+=4 ) {
        *l_ptr++ = ldat;
        ldat = ~ldat;
    }
    l_ptr = (unsigned long far *) MK_FP( 0xD800, 0x18 );
    ldat = (unsigned long) pat[x];
    for( i = 0x18; i < 0x8000; i+=4 ) {
        lrd = *l_ptr++;
        if( ldat != lrd ) {
            printf("FAILED\nLONG DATA @ ADDR: %Fp WR: %.8X RD: %.8X\n",
                --l_ptr, ldat, lrd );
            exit( 1 );
        }
        ldat = ~ldat;
    }
}
/* fill and test buf with DATA = ADD LONG */
for( x = 0; x < 4; x++ ) {
    l_ptr = (unsigned long far *) MK_FP( 0xD800, 0x18 );
    for( i = 0x18; i < 0x8000; i+=4 ) {
        *l_ptr++ = i;
    }
    l_ptr = (unsigned long far *) MK_FP( 0xD800, 0x18 );
    for( i = 0x18; i < 0x8000; i+=4 ) {
        lrd = *l_ptr++;
        if( lrd != i ) {
            printf("FAILED\nDATA=ADDR @ ADDR: %Fp WR: %.8X RD: %.8X\n",
                --l_ptr, i, lrd );
            exit( 1 );
        }
    }
}
}
printf("PASSED\n\n");
exit( 0 );
} /* end main */

```

## Directory Timers

This directory contains sample code useful in the creation of applications involving the VMEbus CPU's three software controlled 16-bit timers. The code is written for the control of a single timer, but can be utilized in generating code for any timer configuration. The timers are described in Chapter 4 of the manual.

Because of the wide variety of environments in which the VMEbus CPU operates, the samples provided in this appendix are not intended to be used verbatim. Rather, they are intended to provide the end user an example of the standard structure of the operating code.

## CPU.H

```

/*
** FILE: T7698T.H
**
*/
#define DID_PWR_MGM      0x7113
#define VID_PWR_MGM     0x8086
#define IRQ5             0x0D
#define GPI_T1          0x80 /* PIX General Purpose Input 15 (tmr 1) */
#define GPI_T2          0x40 /* PIX General Purpose Input 14 (tmr 2) */
#define GPI_T3          0x20 /* PIX General Purpose Input 13 (tmr 3) */
#define GPO_T1          0x40 /* PIX General Purpose Output 30 (tmr 1) */
#define GPO_T2          0x10 /* PIX General Purpose Output 28 (tmr 2) */
#define GPO_T3          0x08 /* PIX General Purpose Output 27 (tmr 3) */
#define GPO_CLR         0xA7 /* PIX General Purpose Output CLR TMRS */
#define TIMER_CNTR1     0x00 /* Timer counter 1 offset */
#define TIMER_CNTR2     0x01 /* Timer counter 2 offset */
#define TIMER_CNTR3     0x02 /* Timer counter 3 offset */
#define TIMER_CNTL      0x03 /* Timer control offset */
/*****
/* 8254 Control word
/*****
#define CW_SC0           0x00 /* W Selcect counter 0 */
#define CW_SC1           0x40 /* W Selcect counter 1 */
#define CW_SC2           0x80 /* W Selcect counter 2 */
#define CW_RBC           0xC0 /* W Read back command */
#define CW_CLC           0x00 /* W Cntr latch command (cnt/stat) */
#define CW_SLC           0x00 /* W Status latch command */
#define CW_LSB           0x10 /* W LSB only */
#define CW_MSB           0x20 /* W MSB only */
#define CW_LSBMSB        0x30 /* W LSB first then MSB */
#define CW_M0            0x00 /* W Mode 0 */
#define CW_M1            0x02 /* W Mode 1 */
#define CW_M2            0x04 /* W Mode 2 */
#define CW_M3            0x06 /* W Mode 3 */
#define CW_M4            0x08 /* W Mode 4 */
#define CW_M5            0x0A /* W Mode 5 */
#define CW_BCD           0x01 /* W Binary Coded Decimal */
#define CW_RB_CNT        0x00 /* W Read back count */
#define CW_RB_STAT       0x00 /* W Read back status */
#define CW_RB_C0         0x02 /* W Read back counter 0 */
#define CW_RB_C1         0x04 /* W Read back counter 1 */
#define CW_RB_C2         0x08 /* W Read back counter 2 */

```

## \*\* FILE: T\_TIMERS.C

```

/*****
/* FILE: T_TIMER.C */
/* */
/*****
#include <stdlib.h>
#include <stdio.h>
#include <string.h>
#include <conio.h>
#include <ctype.h>
#include <dos.h>
#include "pci.h"
#include "cpu.h"
/* T_TIMER.C function prototypes */
void do_exit( int );
/* TIMERS.C function prototypes */
void far interrupt irq_rcvd( void );
void init_timer_int( void );
void restore_orig_int( void );
void load_counter( int, unsigned int );
void read_counter( int, unsigned int *, unsigned char * );
/* global variables */
unsigned char bus, dev_func;
/* the following globals are used in other files as 'extern' variables */
unsigned char tmr_status, t1_stat, t2_stat, t3_stat;
unsigned int tmr_cnt, t1_cnt, t2_cnt, t3_cnt;
unsigned long t1_count; /* counts no. of times timer 1 ISR entered */
unsigned long t2_count; /* counts no. of times timer 2 ISR entered */
unsigned long t3_count; /* counts no. of times timer 3 ISR entered */
unsigned int pwr_mgm_base;
unsigned int gpi_base;
unsigned int gpo_base;
unsigned int timer_base;
unsigned char picl_org;
unsigned char gpo_org;
void main( int argc, char * argv[] )
{
    unsigned long t1, t2, t3;
    int test_int;
    unsigned long temp_dword;
    char user[80];
    timer_base = 0x500;
    /* try to locate the power management device on the PCI bus */
    test_int = find_pci_device(DID_PWR_MGM, VID_PWR_MGM, 0,
        &bus, &dev_func);
    if(test_int != SUCCESSFUL)
    {
        printf("\nUnable to locate power management device on PCI bus\n");
        do_exit( 1 );
    }
    /* get base address from config area */
    test_int = read_configuration_area(READ_CONFIG_DWORD,
        bus, dev_func, 0x40, &temp_dword);
    if(test_int != SUCCESSFUL)
    {
        printf("\nUnable to read POWER MGM. BASE ADDRESS @ 0x40 in config space\n");
        do_exit( 1 );
    }
    pwr_mgm_base = temp_dword & 0x0000FFC0;
    gpi_base = pwr_mgm_base + 0x31; /* PIX general purpose input bits 8-15 */
    gpo_base = pwr_mgm_base + 0x37; /* PIX general purpose output bits 24-31 */
    disable();
    /* Read 8259 slave Programmable Interrupt controller */
    picl_org = inp(0x21) & 0xFF; /* slave mask bits */
    /* disable interrupt 5 */
    outp(0x21, (picl_org | 0x20) ); /* 0 = enable 1 = disable */
    enable();
    gpo_org = inp( gpo_base ) & 0xFF;
    /* setup timers interrupt service routine */
    init_timer_int();
    /*
    ** verify all three counters can generate an interrupt (counters 1,2,3)
    */
    printf("\nTesting all three 16 bit counters for interrupt ...");

```

```

/* setup for interrupts to occur */
t1_count = 0;
t2_count = 0;
t3_count = 0;
t1 = 0;
t2 = 0;
t3 = 0;
tmr_status = 0;
test_int = 100;
/* load counters */
load_counter( 1, 0xFFFF );
do
{
    if( t1_count ) {
        t1++;
        break;
    }
    test_int--;
    delay( 1 );
} while( test_int );
/* disable timers by reloading the control word */
outp( timer_base + TIMER_CNTL, (CW_SC0 | CW_LSBMSB | CW_M2) );
tmr_status = 0;
test_int = 100;
load_counter( 2, 0xFFFF );
do
{
    if( t2_count ) {
        t2++;
        break;
    }
    test_int--;
    delay( 1 );
} while( test_int );
/* disable timers by reloading the control word */
outp( timer_base + TIMER_CNTL, (CW_SC1 | CW_LSBMSB | CW_M2) );
tmr_status = 0;
test_int = 100;
load_counter( 3, 0xFFFF );
do
{
    if( t3_count ) {
        t3++;
        break;
    }
    test_int--;
    delay( 1 );
} while( test_int );
/* disable timers by reloading the control word */
outp( timer_base + TIMER_CNTL, (CW_SC2 | CW_LSBMSB | CW_M2) );
/* clear all three status bits in GPI */
outp( gpo_base, ( gpo_org & GPO_CLR ) );
/* set all three GPO outputs to 1 to allow int status registers to function */
outp( gpo_base, ( gpo_org | GPO_T1 | GPO_T2 | GPO_T3 ) );
if( t1 && t2 && t3 )
{
    printf("PASSED\n");
}
else
{
    printf("FAILED\n");
    if( !t1 ) printf("TIMER 1 failed\n");
    if( !t2 ) printf("TIMER 2 failed\n");
    if( !t3 ) printf("TIMER 3 failed\n");
    do_exit( 2 );
}
/* do orderly exit */
do_exit( 3 );
} /* end main */
void do_exit( int xit_code )
{
    if( xit_code > 1 ) restore_orig_int();
    outp( gpo_base, gpo_org );
    if( xit_code == 3 ) xit_code = 0;
    exit( xit_code );
} /* do_exit */
** FILE: TIMERS.C
/*
** FILE: TIMERS.C

```

```
**
*/
#include <stdlib.h>
#include <stdio.h>
#include <dos.h>
#include <ctype.h>
#include <conio.h>
#include "cpu.h"
/* function prototypes */
void far interrupt irq_rcvd( void );
void init_timer_int( void );
void restore_orig_int( void );
void load_counter( int, unsigned int );
void read_counter( int, unsigned int *, unsigned char * );
/* global variables */
extern unsigned long t1_count; /* timer 1 count */
extern unsigned long t2_count; /* timer 2 count */
extern unsigned long t3_count; /* timer 3 count */
extern unsigned char tmr_status;
extern unsigned int gpi_base;
extern unsigned int gpo_base;
extern unsigned int timer_base;
extern unsigned char pic1_org;
extern unsigned char gpo_org;
void far interrupt (* old_vect)(void);
/*****
*/
/* init_timer_int()
*/
/* purpose: Using the interrupt assigned, the original vector is
*/
/* saved and the vector to the new ISR is installed. The
*/
/* programmable-interrupt-controller (PIC) is enabled.
*/
/*
*/
/* Prerequisite: The interrupt line to be used must have
*/
/* already been loaded in the global variable.
*/
/*
*/
/*****
*/
/* parameters: none
*/
/*****
*/
/* return value: none
*/
/*****
*/
void init_timer_int( void )
{
    disable();
    old_vect = getvect( IRQ5 ); /* save vector for IRQ5 */
    setvect( IRQ5, irq_rcvd );
    /* enable interrupt 5 */
    outp(0x21, (pic1_org & 0xDF) ); /* 0 = enable 1 = disable */
    /* clear all three GPO inputs */
    outp( gpo_base, ( gpo_org & GPO_CLR ) );
    /* set all three GPO outputs to 1 to allow int status registers to function */
    outp( gpo_base, (gpo_org | GPO_T1 | GPO_T2 | GPO_T3 ) );
    enable();
} /* init_timer_int */
/*****
*/
/* restore_orig_int()
*/
/* purpose: Using the interrupt assigned, the original vector is
*/
/* restored and the programmable-interrupt-controller
*/
/* is disabled.
*/
/*
*/
/* Prerequisite: The interrupt line to be used must have
*/
/* already been loaded in the global variable.
*/
/*
*/
/*****
*/
/* parameters: none
*/
/*****
*/
/* return value: none
*/
/*****
*/
void restore_orig_int( void )
{
    disable();
    outp(0x21, pic1_org);
    setvect( IRQ5, old_vect );
    enable();
} /* restore_orig_int */
```

```

/*****
/* load_counter()
/*
/* purpose: Loads the appropriate counter with the count passed
/*
/*
/*
/*****
/* parameters: int counter = 1, 2, 3 for COUNTER 1, 2, or 3
/*
/* unsigned int count = count to be loaded
/*
/*****
/* return value: none
/*
/*****
void load_counter( int counter, unsigned int count )
{
    int lsb, msb;
    lsb = count & 0xff;
    msb = count >> 8;
    switch( counter )
    {
        case 1: /* select counter 1, LSB then MSB, mode 2 */
            outp( timer_base + TIMER_CNTL, (CW_SC0 | CW_LSBMSB | CW_M2) );
            outp( timer_base + TIMER_CNTR1, (unsigned char) lsb );
            outp( timer_base + TIMER_CNTR1, (unsigned char) msb );
            break;
        case 2: /* select counter 2, LSB then MSB, mode 2 */
            outp( timer_base + TIMER_CNTL, (CW_SC1 | CW_LSBMSB | CW_M2) );
            outp( timer_base + TIMER_CNTR2, (unsigned char) lsb );
            outp( timer_base + TIMER_CNTR2, (unsigned char) msb );
            break;
        case 3: /* select counter 3, LSB then MSB, mode 2 */
            outp( timer_base + TIMER_CNTL, (CW_SC2 | CW_LSBMSB | CW_M2) );
            outp( timer_base + TIMER_CNTR3, (unsigned char) lsb );
            outp( timer_base + TIMER_CNTR3, (unsigned char) msb );
            break;
    }
} /* load_counter */
/*****
/* read_counter()
/*
/* purpose: Reads the appropriate counter in the appropriate
/* bank with the remaining count and status.
/*
/*
/*
/*****
/* parameters: int counter = 1, 2, 3 for COUNTER 1, 2, or 3
/*
/* unsigned int * count = remaining count
/*
/* unsigned char * status = counter status
/*
/*****
/* return value: none
/*
/*****
void read_counter( int counter,
                  unsigned int * count, unsigned char * status )
{
    int lsb, msb;
    switch( counter )
    {
        case 1: /* select counter 1, LSB then MSB */
            outp( timer_base + TIMER_CNTL, ( CW_RBC | CW_RB_CNT | CW_RB_STAT | CW_RB_C0 )
);
            *status = inp( timer_base + TIMER_CNTR1 ) & 0xFF;
            lsb = inp( timer_base + TIMER_CNTR1 ) & 0xFF;
            msb = inp( timer_base + TIMER_CNTR1 ) & 0xFF;
            msb = msb << 8;
            *count = ( lsb | msb );
            break;
        case 2: /* select counter 2, LSB then MSB */
            outp( timer_base + TIMER_CNTL, ( CW_RBC | CW_RB_CNT | CW_RB_STAT | CW_RB_C1 )
);
            *status = inp( timer_base + TIMER_CNTR2 ) & 0xFF;
            lsb = inp( timer_base + TIMER_CNTR2 ) & 0xFF;
            msb = inp( timer_base + TIMER_CNTR2 ) & 0xFF;
            msb = msb << 8;
            *count = ( lsb | msb );
            break;
        case 3: /* select counter 3, LSB then MSB */
            outp( timer_base + TIMER_CNTL, ( CW_RBC | CW_RB_CNT | CW_RB_STAT | CW_RB_C2 )
);

```

```

);
    *status = inp( timer_base + TIMER_CNTR3 ) & 0xFF;
    lsb = inp( timer_base + TIMER_CNTR3 ) & 0xFF;
    msb = inp( timer_base + TIMER_CNTR3 ) & 0xFF;
    msb = msb << 8;
    *count = ( lsb | msb );
    break;
}
} /* read_counter */
/*****
/* irq_rcvd()
/*
/* purpose: Interrupt service routine used to service any of the
/* counters on the 7698.
/*
/*
/*
/*****
/* parameters: none
/*****
/* return value: none
/*****
void interrupt irq_rcvd(void)
{
    disable();
    asm {
        .386P
        push eax
        push ebx
    }
    tmr_status = inp( gpi_base ) & 0xFF;
    /* increment counts and clear status */
    if( tmr_status & GPI_T1 ) {
        t1_count++;
        outp( gpo_base, (gpo_org & (~GPO_T1)) ); /* clear timer 1 status bit */
    }
    if( tmr_status & GPI_T2 ) {
        t2_count++;
        outp( gpo_base, (gpo_org & (~GPO_T2)) ); /* clear timer 2 status bit */
    }
    if( tmr_status & GPI_T3 ) {
        t3_count++;
        outp( gpo_base, (gpo_org & (~GPO_T3)) ); /* clear timer 3 status bit */
    }
    outp( gpo_base, (gpo_org | GPO_T1 | GPO_T2 | GPO_T3) ); /* enable status */
    /* Non specific end of interrupt to PIC */
    outp(0x20, 0x20); /* Master end of irq command */
    asm {
        .386P
        pop ebx
        pop eax
    }
    enable();
}

```

## Directory WATCHDOG

This directory contains sample code useful in the creation of applications involving the VMEbus CPU's watchdog timer function as described in Chapter 4.

Because of the wide variety of environments in which the VMEbus CPU operates, the samples provided in this appendix are not intended to be used verbatim. Rather, they are intended to provide the end user an example of the standard structure of the operating code.

### \*\* FILE: WATCHDOG.H

```

/*
** DS1384 REGISTER OFFSETS
*/
/*
/* 7 6 5 4 3 2 1 0 */
#define CLK_MSEC 0x00 /* 00-99 */
#define CLK_SEC 0x01 /* 00-59 0 */
#define CLK_MIN 0x02 /* 00-59 0 */
#define CLK_MINAL 0x03 /* 00-59 M */
#define CLK_HRS 0x04 /* 01-12+A/P OR 00-23 */
#define CLK_HRSAL 0x05 /* 01-12+A/P OR 00-23 */
#define CLK_DAY 0x06 /* 01-07 0 0 0 0 0 */
#define CLK_DAYAL 0x07 /* 01-07 M 0 0 0 0 */
#define CLK_DATE 0x08 /* 01-31 0 0 */
#define CLK_MONTH 0x09 /* 01-12 0 */
#define CLK_YRS 0x0A /* 00-99 */
#define WD_CMD 0x0B /* command register */
#define WD_MSEC 0x0C /* milli second watchdog time */
#define WD_SEC 0x0D /* seconds watchdog time */
/*
** DS1384 COMMAND REGSITER BIT DEFINITIONS
*/
#define WD_TE 0x80 /* transfer enable 1 - allow updates */
#define WD_IPSW 0x40 /* interrupt switch 0 - WD out INTA */
#define WD_IBHL 0x20 /* int. B output 0 - current sink */
#define WD_PU 0x10 /* pulse/level 1 - 3 ms pulse */
#define WD_WAM 0x08 /* watchdog alarm mask 0 - active */
#define WD_TDM 0x04 /* time-of-day alarm mask 0 - active */
#define WD_WAF 0x02 /* watchdog alarm flag */
#define WD_TDF 0x01 /* time-of-day flag */

```

## \*\* FILE:WDTO.C

```

/*****
/* FILE: WDTO_RST.C
/*
/* Setup watchdog to issue reset on time out.
/*
/*
/*****
#include <stdlib.h>
#include <stdio.h>
#include <dos.h>
#include <time.h>
#include <conio.h>
#include <ctype.h>
#include "watchdog.h"
unsigned char far * wd_ptr;
time_t t;
char usr[80];
char reg_b;
void main( void ) {
    /* Install WATCHDOG RESET Jumper */
    wd_ptr = (unsigned char far *) MK_FP( 0xD800, 0 );
    /* set WatchDog Alarm Mask 1 - deactivated and update with 0 time */
    *(wd_ptr + WD_CMD) = ( WD_TE | WD_WAM );
    *(wd_ptr + WD_MSEC) = 0; /* load with 0 to disable */
    *(wd_ptr + WD_SEC) = 0; /* load with 0 to disable */
    *(wd_ptr + WD_CMD) = ( WD_TE | WD_WAM ); /* allow update with 0 time */
    *(wd_ptr + WD_CMD) = WD_WAM; /* set watchdog alarm mask to 1 */
    *(wd_ptr + WD_MSEC) = 0x99; /* 00.99 seconds */
    *(wd_ptr + WD_SEC) = 0x99; /* 99.00 seconds */
    *(wd_ptr + WD_CMD) = ( WD_TE | WD_PU ); /* set for 3 ms pulse */
    printf("Reset time out in 99.99 seconds\n\n");
    time(&t);
    printf("START DATE & TIME: %.24s\n\n", ctime(&t) );
    do {
        time(&t);
        printf("CURRENT DATE & TIME: %.24s\r", ctime(&t) );
        delay( 250 );
    } while( !kbhit() );
} /* end main */

```